



CONSUL DRIVES LIKE FUN! SAVES LIKE CRAZY!

# Cortina



**A TOTALLY NEW CONCEPT  
IN ECONOMY MOTORING . . .  
ALTOGETHER A FRESH,  
ORIGINAL AND  
PRACTICAL CAR!**

The new-sized Ford — Cortina — is a completely new concept in the economy-car field. It is the first car ever to brilliantly combine sports-car performance and handling . . . family-sized room and luggage-space . . . the running economics of smaller cars . . . at a price that's hard to believe.

It is beautiful to look at — and engineered to be more service-free with greater savings in time and money. Like a rocket plane, it hasn't a wasted pound or an ugly line. These clean curves and angles slip through the wind to save fuel and get the most out of Cortina's big and easy power. They also conceal Cortina's rugged strength. Give Cortina any test . . . and make it tough. It is built to *merit* your closest inspection and *thrive* on anyone's comparison.

The Cortina is marvellously manoeuvrable — parking, steering, threading through traffic are delightfully easy. Yet it can cruise quietly and effortlessly all day at maximum highway speeds. There's a whole new dimension and fun to driving.

Finally, the Cortina is built by Ford, the result of over three years development. It brings you many engineering advancements and a quality construction unrivalled by any other economy car.

Drive it. Price it. Compare it. You'll find Cortina your most startling experience in motoring today.

**Drives like FUN! Saves like CRAZY!**

CONSUL  
**Cortina**

# More room and convenience than you ever dreamed possible in a car at Cortina's low, low price!



## URNS IN ONLY 32'

Cortina's amazingly small turning circle of 32 feet makes manoeuvring in busy traffic and parking in tight places a joy. And for even more parking-ease all four "corners" of Cortina are visible to the driver.



## SUPER QUIETNESS ON THE ROAD

Take a Cortina out on the road and you'll see quality come alive. The ride is so silent . . . so vibration-free you'll feel as if you're in a car much more expensive than Cortina. Body insulation of many types surround the passenger compartment to provide a thick, sound-muting, noise-deadening barrier. There's also thick insulation under the roof to keep you cool in summer, warm in winter.



## DOORS SO WIDE YOU CAN EVEN WALK THROUGH TO THE REAR

Slip in with ease to the front or the rear of Cortina through the widest of doors—over 41 inches wide. And you need never slam a Cortina door—they are carefully counter-balanced and feature new "non-slam" zero-torque locks. Just a finger-tip swing and they close with a solid, muted click that says quality in a way you'll be delighted to hear.

## GREATER INTERIOR ROOM THAN HAS EVER BEEN OFFERED BY AN ECONOMY-CAR BEFORE

Open Cortina's extra-wide doors and its roominess comes as an eye-catcher. Here are all-new and bigger dimensions for a car carrying Cortina's low price tag. It has more shoulder, hip and legroom than any other car in its class (some dimensions are bigger than much more expensive cars), and seats five people in easy comfort.

The front bucket seats are contoured and individually adjustable. All seats have deep layers of soft foam rubber for extra comfort and to eliminate fatigue on the longest of trips.

Every instrument is clearly marked for easy identification, every control conveniently placed within easy reach of the driver. Drivers will appreciate Cortina's vision—over 3,000 square inches of safety glass let you see all round, the bonnet sleeks down to reveal the maximum amount of road.

The interior itself is very carefully appointed, with a full-width parcel tray beneath the dashboard, another under the big rear window, a cowl and safety-padded instrument panel, door-pull armrests in the front, two interior sun visors to shield you from sun glare and safety-belt anchors should you want to have seat-belts fitted. As you open Cortina's doors a bright dome light switches on.

You can pick from any one of five interior trims to team elegantly with body colors.

## CORTINA BOASTS ALL THE MOST WANTED FEATURES AS STANDARD EQUIPMENT:

- Dual sun visors
- Foam-cushioned dashboard
- Glove box
- Front parcel tray
- Rear parcel tray
- Door and hand-operated dome light
- Ash trays front and rear
- Door-pull armrests on front doors
- Wide-sweeping electric windscreen wipers
- Thick roof insulation
- Dual horns
- Turn indicators
- Two-spoke safety steering wheel
- Safety glass all round
- Safety door-locks
- Choice of two-tone interiors in combination vinyl/cloth fabrics
- Color-keyed steering wheel
- Completely draught-free rear quarter vents
- Foam-padded seats
- Luggage boot mat
- Seat belt anchor points

Outside ad in, the Cortina welcomes its passengers in ways that are Cortina's alone. This lithe and handsome newcomer knows no boundaries. It drives happily over every limitation set for a economy car.

## THE BIGGEST LUGGAGE SPACE EVER FOR A QR IN CORTINA'S CLASS!

Swing up Cortina's extra deep and wide boot lid and you're in for one of the biggest surprises. The boot holds a vast 21 cubic feet of luggage. That's a capacity twice as big as some cars in Cortina's field—and bigger than some cars costing hundreds more. Large suitcases and parcels can be stowed with ease, too. Cortina's boot floor is flat, its dimensions deep, wide and high.

Notice the position of the spare tyre, too. You don't have to move anything to reach it, or lift a section of the floor to get it out.

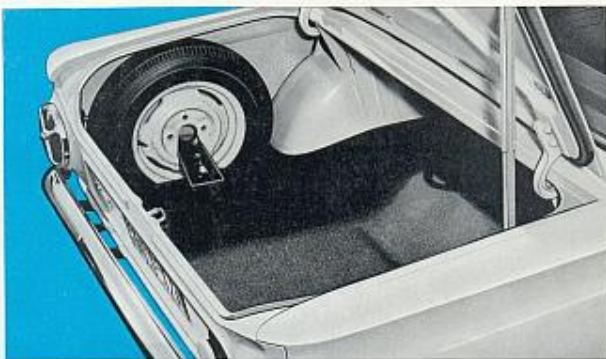

# Cortina power team: key to big performance, big economy, great endurance!

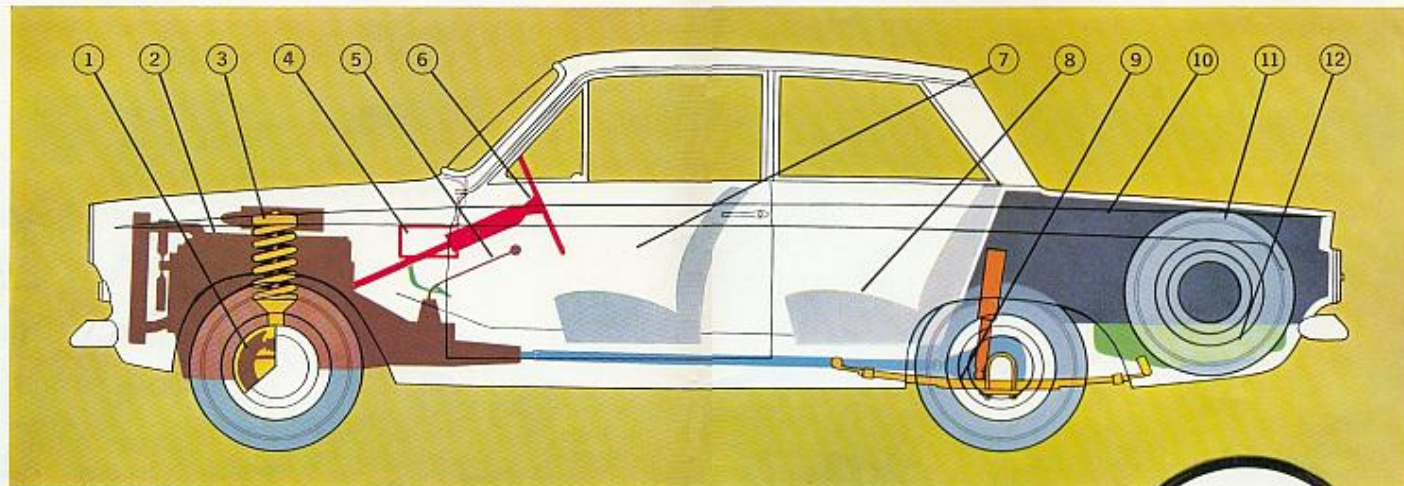

## DESIGNER'S DREAM BECOMES REALITY!

- 1. REALLY BIG BRAKES** — a huge 81.68 sq. ins. of braking surface for instant, sure stopping.
- 2. RACE-PROVED ENGINE** — with best power-to-weight ratio in Cortina's price class. 53.5 brake horsepower . . . 66.5 lbs./ft. torque.
- 3. SMOOTH GOING** over any road. Trial-proved, independent, heavy-duty coil-spring suspension . . . hydraulic double-acting shock absorbers . . . stabiliser bar embodied.
- 4. EXTRA-WIDE, EXTRA-DEEP PARCEL TRAY** stretches full width of the car — is in addition to the roomy glove box.
- 5. WORLD'S SIMPLEST AND FASTEST GEAR SHIFTS** from a fantastic 4-speed gearbox that is synchromesh even on "first".
- 6. EASIEST-EVER HANDLING AND PARKING** with recirculatory ball-type steering, and a turning circle of only 32 feet. Wonderful for busy city streets.
- 7. DOORS SO WIDE** rear passengers can walk straight through to the rear.
- 8. 3 IN THE REAR — COMFORTABLY!** Yes, Cortina's a true family-sized car . . . big inside and with many luxury features, too!
- 9. EXTRA-LONG, EXTRA-STRONG REAR SPRINGS** are self levelling, help provide Cortina's unique BIG-CAR ride and smoothness.
- 10. FAMILY-SIZED LUGGAGE BOOT** — biggest by far in Cortina's price class — has giant 21 cubic feet capacity.
- 11. TUCK-AWAY SPARE TYRE** — sensibly stowed up-right on the side, it doesn't obstruct luggage space, slips out in a second when needed.
- 12. A BIG 8-GALLON FUEL TANK** for touring over 300 miles on a tank-full of petrol.



Instrument reading at its easiest! The striking and simple fascia layout presents the instruments (oil, indicator and ignition warning lights, speedometer, odometer and fuel gauge) right before the driver's eyes. When road and traffic need full attention it's still easy to see what they say. The dashboard is thickly padded, and cowed to avoid reflections. The horn, lights and turn-indicator switches are grouped so that you need never lift your hand from the steering wheel — they're at your finger-tips on a control arm just under the steering wheel.

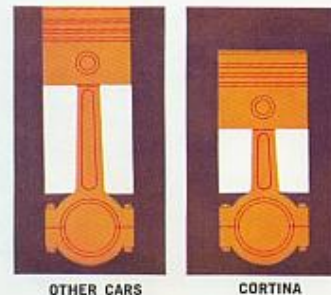
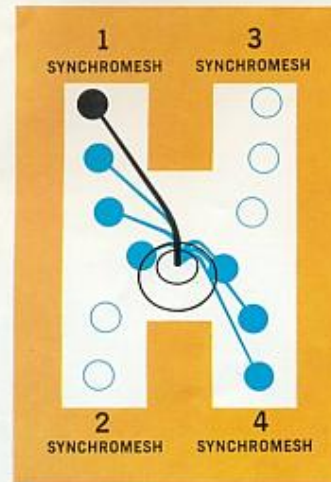

Until now, no economy car has brought you the kind of driving that Cortina brings you. It has a performance that will be rated nothing short of sensational by even the most ardent sports-car enthusiasts . . . delivers an economy that competes with far smaller cars . . . gives a ride that can be compared to cars far more expensive . . . and has great endurance qualities.

### AN ENGINE THAT'S PURE RACE-BRED!

The Cortina has a remarkable engine. High efficiency, oversquare, valve-in-head, it packs tremendous power. In basic design it is identical to the famous Ford 105E engine which powers the record-breaking Lotus and other Formula Junior racing cars. To this world-successful design has been added a bigger capacity — Cortina's 1198 c.c. engine harnesses 53.5 horsepower and 66.5 lbs./ft. of torque. You'll be amazed how Cortina accelerates so fast, reaches and maintains high cruising speeds so effortlessly, and takes the longest hills so easily in its stride.

### A GEARBOX YOU CAN PLAY A TUNE WITH!

It's all yours — silk-smooth changing, and the pleasure and thrill of sports-car driving from a floor-mounted 4-speed gear shift that's synchromesh all the way through! You call the tune in Cortina with just an easy flick of your hand.

### A MONEY-SAVER RIGHT DOWN THE LINE!

From the moment you get it, your Cortina saves your money. You'll go up to 40 miles per gallon . . . oil changes and routine servicing are required only twice a year or each 6,000 miles. And service is no problem to a Cortina owner. You'll find modern up-to-date facilities and equipment, and specially trained mechanics at all Ford Dealerships throughout Australia. Costs are low. Service is fast.

◀ Cortina's oversquare design engine is an extremely short stroke engine for low piston speeds and shorter piston travel per mile. This means low friction, less wear on moving parts, and remarkable endurance for countless miles on the highway.

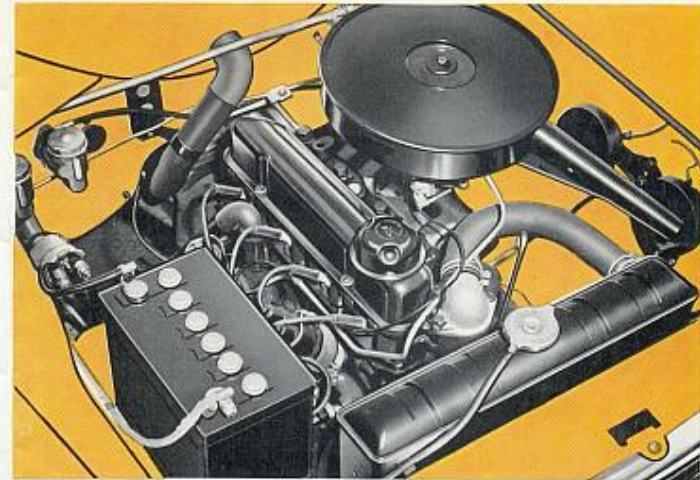

### RIDES SMOOTH — CORNERS FLAT!

Lean your Cortina into a fast turn, take to a twisting mountain road — you'll marvel at its complete absence of "drift", revel in its sure-footed cornering. The reasons: a phenomenal 98 inches long wheelbase, front and rear tracks almost 50 inches wide, and a centre of gravity that's the best in the business.

### DESIGNED FOR STAMINA!

Cortina's strength and durability are tremendous. It has more than 800 spot weld points; big independent coil springs, with hydraulic double-acting shock absorbers and solid steel stabiliser bars, give great toughness up front; heavy-duty longitudinal semi-elliptic leaf springs match them at the rear.

Tested against other cars in endurance tests over brutal destructive surfaces, the Cortina rode happily on, three and four times as long again after the other cars had broken up.

### STOPS SURE, FAST AND STRAIGHT!

High performance calls for a high standard of safety — the kind of safety that 81.68 square inches of braking surface can give you. These big outside brakes provide perfect fade-free, straight line stopping, and "bite in" with just light pedal pressure.



# CONSUL Cortina

## Specifications

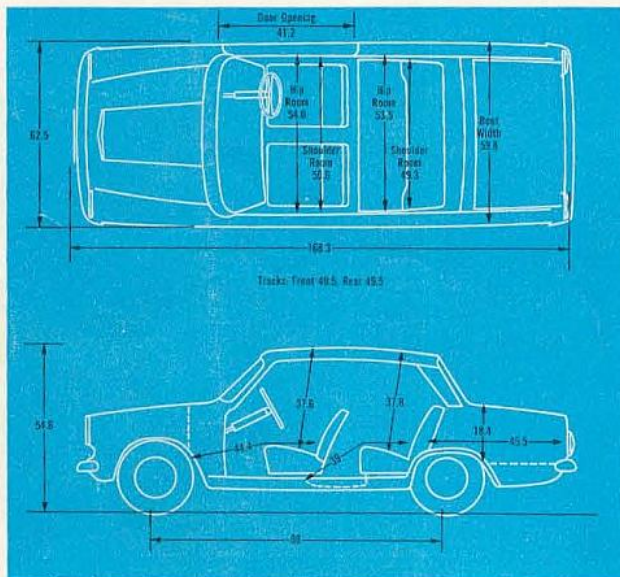

12,000 MILES OR 12 MONTHS

(whichever comes first)

## WARRANTY

Ford-Australia was first in providing the great owner-protection of the "12/12 Warranty" simply because it was Ford who built the cars to warrant such a warranty. As with every Ford-built vehicle, the new Cortina has been built to the industry's highest standard for quality, durability and reliability. Cortina's warranty covers both parts and labour for the full warranty period. As a Cortina owner, you remain responsible only for the normal maintenance service and routine replacement of maintenance items.

**Engine:** 4 cylinder in line 1198 cc  
Bore 3.1875 ins.  
Stroke 2.29 ins.  
Overhead Valves  
Compression Ratio 8.7 : 1  
Maximum gross B.H.P. 53.5 b.h.p. at 5000 r.p.m.  
Maximum gross Torque 66.5 lbs. ft. at 2700 r.p.m.

**Lubrication:** Pressure feed to main bearings, camshaft and connecting rods. Sump capacity 4½ pints (including filter).

**Suspension:** Front—Built-in independent coil spring suspension. Hydraulic double acting shock absorbers. Stabiliser bar embodied.  
Rear—Longitudinal semi-elliptic leaf springs.

**Transmission:** Single dry plate clutch 7.25 ins. diameter — hydraulically operated. Four forward speeds and reverse with blocker type synchromesh on all forward gears. Ratios 1st 14.62 : 1, 2nd 9.883 : 1, 3rd 5.824 : 1, Top 4.125 : 1, Reverse 16.35 : 1. Rear Axle Ratio 4.125 : 1. Gearbox oil capacity 1.75 pints.

**Electrical system:** Battery 12 volt 38 amp/hour. Coil ignition with automatic advance and retard.

**Steering:** Recirculating ball type ratio 15 : 1. Turning circle 32 ft. Two spoke 16" diam. steering wheel.

**Cooling system:** Water cooled with modine type radiator core. Centrifugal type pump driven by "V" belt from the crankshaft.

**Controls:** Lighting dipper switch, direction indicator switch and horn control operated from antenna on steering column. Choke control, windscreen wiper switch, combined ignition and starter switch.

**Brakes:** Front—Cast drum 8 x 1¾ in. diam., twin leading shoe.  
Rear—Cast drum 8 x 1½ diam., one leading one trailing shoe.  
Total Lining Area 81.68 sq. ins.

**Fuel system:** Single down draught carburettor. Mechanical diaphragm fuel pump. Fuel tank capacity 8 Imperial gallons.

**Tyres:** 5.20 x 13, 4 ply, tubeless. Options: white sidewall.

**Body:** All steel welded integral construction. Safety glass all round. Curved windscreen. Hinged no-draught front ventilator windows with press button safety catches. Opening rear quarter windows.

Press button door handles, exterior lock on driver's side, inside lock on passenger door. Padded arm rest/door pulls. Two-tone door and seat trim. Separate bucket type adjustable front seats. Separate luggage compartment approximately 21 cubic feet capacity. Spare wheel located vertically in well in offside rear guard.

**Miscellaneous equipment:** Door pull arm rests. Two sun visors. Interior light with courtesy switches on both doors. Three ashtrays. Glove compartment with lid. Front parcel tray. Crash pad. Opening rear quarter vents. Luggage compartment mat. Color keyed steering wheel. Seat belt anchorage points.

*The specifications contained herein were in effect at the time this catalogue was approved for printing. Ford Motor Company of Australia Pty. Ltd., whose policy is one of continuous improvement, reserves the right, subject to such regulations as may from time to time apply, to change specifications and prices at any time without notice or incurring liability to purchasers. Some of the items illustrated or referred to are optional at extra cost.*