



Volkswagen

The Caddy



Perfect for all that everyday life has in store.

Caddy People Mover.

Caddy Maxi Trendline



Caddy Trendline



NEW GENERATION PETROL ENGINE

with BlueMotion Technology standard.

LOW FUEL CONSUMPTION.

From as low as
6.0 L/100km[#].

STATE OF THE ART INFOTAINMENT SYSTEMS.

New radios and functions, intuitive
control and excellent connectivity.

MAXIMUM FUNCTIONALITY AND FLEXIBILITY.

Wide sliding doors and folding, double-folding and removable
rear seats.

HIGH STANDARDS IN MATTERS OF SAFETY.

Forward Collision with City Emergency Braking*,
Multi-collision Brake and Driver Fatigue Detection*
systems, plus six airbags as standard.

LATEST DRIVER ASSISTANCE SYSTEMS.

From Adaptive Cruise Control* to "Front Assist" with City
Emergency Braking* to a Rear View Camera*.

LOW LOADING SILL HEIGHT.

For easier loading and unloading.

Caddy Maxi Comfortline



Standard for Caddy Trendline.

Available in Short (5 seat) and Maxi (7 seat) body styles

Exterior

- Halogen headlights
- Daytime Running Lights (DRL)
- Dual sliding doors, 701mm wide
- Body coloured bumpers, door handles, mirror housings and cover plate for sliding doors
- Tailgate with spoiler and soft touch closing system
- 16-inch steel wheels with wheel covers

Interior

- Second row of seats, folding and removable
- Third row of seats, folding and removable (optional for Short)
- Cleverly thought out storage system including roof shelf
- Leather-wrapped steering wheel, height and reach adjustable
- "Kutamo" cloth seat upholstery
- Central console with centre armrest and three cup holders
- Front seats, height adjustable, with storage underneath
- "Dark Silver Brushed" decorative trims
- Luggage compartment cover

Function

- Start/stop system and regenerative braking
- Bluetooth® phone and audio streaming compatibility
- "Composition Colour" radio system with USB/AUX/SD
- Multi-function display trip computer
- Steering wheel audio controls
- Cruise Control
- Central locking with radio remote control
- Power windows and heated exterior mirrors
- Air conditioning

Safety

- Forward Collision with City Emergency Braking*
- Driver Fatigue Detection*
- Hill-Start Assist
- Multi-Collision Brake (MCB)
- Electronic Stabilisation Programme (ESP)
- Traction Control System (TCS)
- Anti-Lock Braking System and Brake Assist
- Driver and front passenger front and side/head airbags
- Rear curtain shield airbags for 2nd row of seats
- Driver and front-seat passenger seat belt warning
- Servotronic speed-dependent power-assisted steering
- Rear Park Distance Control*
- Rear View Camera*

Additional standard equipment for the Caddy Comfortline.

Available in Maxi (7 seat) body style only

Exterior

- 16-inch "Bendigo" alloy wheels
- Dual halogen headlights
- Colour-coded protective side strips
- Rear privacy glass
- Black roof rails
- Additional chrome accents

Interior

- "Pandu" cloth seat upholstery
- "Checker Plate Titan" decorative trims
- Front seat lumbar support
- Folding tables for second row passengers
- Additional chrome accents

Function

- "Composition Media" radio with App-Connect
- "Climatronic" air conditioning with anti-allergen filter
- 12V socket on upper dashboard
- Centre console armrest longitudinal adjustment

Safety

- Front fog lights
- Light & Sight package

*Safety technologies are designed to assist the driver, but should not be used as a substitute for safe driving practices. ~App-Connect is compatible for selected apps with the latest smartphone versions of iOS and Android, active data service, and connection cable (sold separately).

Space for everything.

Up to seven seats.

Or up to 3,880 litres load volume.

Workdays, Sundays, holidays. Every day is different. That is why the seats in the second row of the Caddy can be easily folded, double-folded or, if necessary, removed. Third row seats (if fitted) can also be folded or removed. This creates the space needed for big shopping trips, and transporting small furniture. The low loading sill height and the even load surface make loading and unloading as easy as possible.

As a 2-seater, the Caddy with short wheelbase boasts an impressive 3,030L loading space volume – ideal for delivery jobs.

Seats
2



The second row of seats is divided in a ratio of $\frac{2}{3}$ and $\frac{1}{3}$. This provides plenty of individually customisable usage possibilities.

Seats
3



Double-folding the second row of seats opens up a loading space volume of 2,852L.



Seats
4



Seats
5

The 3-seater bench seat provides ISOFIX attachment points on the outer seats and top tethers for all three seating positions.

The 2-seater third row bench seat is standard for Caddy Maxi and optional for the short wheelbase model.



The Caddy Maxi is 47cm longer, and offers 530L of luggage space, even with seven people on board.



Overseas model shown.

Interior & Comfort.



01 High quality interior. Take a seat. Enjoy Caddy's redesigned interior with quality trims, comfortable seats, ample storage and many other comfort features.

02 Folding table for rear seats. Practical on long-distance journeys, fold-up tables in the backrests of the front seats provide second row passengers with an easy to clean surface, and an integrated cupholder. | CL |

03 12V sockets. All Caddys have 12V sockets in the front console and at the rear of the centre console, within easy reach of 2nd row passengers. The socket in the luggage area is perfect for charging portable cooler boxes or larger devices. The Caddy Maxi Comfortline has an additional 12V socket in the dashboard upper storage tray.

Leather trims (not illustrated). The leather trimmed gear lever knob and boot, and handbrake lever give Caddy Comfortline a premium look and feel. | CL |

Air conditioning (not illustrated). The semi-automatic air conditioning has an infinite adjustment, so that a pleasant interior temperature can be ensured at all times. Thanks to ergonomic buttons and knobs, the temperature in degrees, air distribution, and fan speed can be easily regulated while driving. | TL |

04 "Climatronic" air conditioning with anti-allergen filter. The "Climatronic" system controls the temperature electronically with the help of an interior sensor, and constantly compares the actual temperature with the desired temperature. Thanks to the 2-zone temperature control, the temperature in degrees can be individually set for the driver and front passenger. At the same time, an air quality sensor monitors the quality of the air outside, and automatically activates the air circulation function, if necessary. | CL |



05 Overhead shelf. The generous overhead shelf lets you store items out of sight, but still within easy reach from the front seats. | TL | CL |

06 Light and Sight package. Sensors dim the rear view mirror automatically when the lights of the vehicle behind are too bright, and regulate the intervals of the windscreen wipers during rain. The automatic driving light control switches the headlights on automatically when it starts to get dark. The package also features "coming home" and "leaving home" functions. | TL | CL |

Exterior.



01 Privacy glass. Tinted side and rear windows for the passenger compartment are standard for Comfortline. They screen the interior from view, and provide excellent protection from solar radiation. | CL |

02 Bi-Xenon headlights. The Bi-Xenon headlights produce both high and low beams, and illuminate the roadway significantly better than conventional halogen headlights. They also impress thanks to their low energy consumption. Offered in conjunction with LED daytime running lights (DRL) and tinted tail lights. | TL | CL |

03 Roof rails. These enhance the appearance of the vehicle and can carry a maximum load of 100kg. The Caddy Comfortline is equipped as standard with a black rail, while a silver version is optionally available for Comfortline. | CL |

04 Tailgate with window. The smooth-functioning tailgate can be opened with one hand. When open, it offers protection from rain and sunshine during loading and unloading. A third brake light is integrated into the spoiler. The tailgate is equipped with a soft touch closing system. | TL | CL |



Overseas model shown.
App-Connect featuring Apple CarPlay®

Technology.

State of the art radio and navigation systems, mobile connectivity

01 App-Connect™. Stay connected wherever you go with App-Connect – one of the world's first smartphone-integrated car infotainment systems that's compatible across three interfaces – Apple CarPlay®, Android Auto™ and MirrorLink®. Once your smartphone has been connected via USB, you can manage a select range of apps straight from the head unit. Fitted with Composition Media and Discover Media systems. | TL | CL |

02 Leather-covered multi-function steering wheel. It gives you a good grip and is extremely user-friendly. The radio or navigation system, a mobile phone or the cruise control can be controlled using the buttons. | TL | CL |

Multi-function display (not illustrated). It shows current information such as the time, remaining range, outside temperature and average consumption. In conjunction with the optional navigation system, it also shows directional arrows for convenient navigation.

| TL | CL |

Mobile phone interface (not illustrated). A wireless Bluetooth® interface enables you to make phone calls safely and conveniently during the journey using a microphone and the vehicle loudspeakers. It can be controlled via the multi-function display or the touch screen display of the radio system. | TL | CL |

-App-Connect is compatible for selected apps with the latest smartphone versions of iOS and Android, active data service, and connection cable (sold separately).



03 Electronic voice amplification. This ensures that the driver does not have to speak loudly in order to talk to the passengers in the rear compartment. The voice input is recorded through a hands-free microphone, amplified, and then transmitted over the loudspeakers in the rear. Only available with "Discover Media".

| TL | CL |

04 Voice control. Greater comfort and safety thanks to the voice control system: You are free to operate the telephone, navigation and audio functions without taking your hands off the steering wheel. Furthermore, you can call up virtually all menus and notifications on the radio or navigation system displays using voice control. Only available with "Discover Media".

07 "Discover Media" navigation system. In addition to the functions of the "Composition Media" radio system, there is a second integrated SD-card slot which is compatible with the SD-card with the map data.

| TL | CL |

05 "Composition Colour" radio system. The system consists of a 12.7 cm (5 inch) TFT colour display, an MP3- and WMA-compatible CD drive, four loudspeakers, an SD-card slot, AUX-IN and USB interface as well as a dual tuner with phase diversity for optimal radio reception. Bluetooth® connection for mobile phone is standard.

06 "Composition Media" radio system. The system consists of a 16.5 cm (6.33 inch) TFT colour display, a touch screen with proximity sensor, an MP3- and WMA-compatible CD drive, six loudspeakers, a dual tuner with phase diversity for optimal radio reception, an SD-card slot, an AUX-IN interface, a USB port and a Bluetooth® connection for mobile phones. App-Connect* is standard with "Composition Media".

| TL | CL |



The latest standards in safety.

The extensive technology package for the Caddy.

To ensure that every drive ends as stress-free as it begins, the Caddy is equipped with various safety systems, which are activated in critical situations as a preventative measure. One of the onboard standard equipment is the Multi-Collision Braking System. Moments after an accident, the vehicle begins a phased braking action down to 10 km/h in order to prevent secondary collisions. Should an impact nonetheless result, driver, front passenger, side/head airbags and for the first time rear curtain shield airbags will provide optimal protection to front and second row passengers.



Driver Fatigue Detection*. Uses visual and acoustic warning signals to recommend that the driver takes a break as soon as it registers driving behaviour that indicates tiredness. | TL | CL |



Anti-Lock Braking System (ABS). Prevents wheel lock and, thus, maintains manoeuvrability. | TL | CL |



Brake Assist System. Registers the speed at which the brake pedal is pressed. During a reflexive or emergency braking action, it ensures that full brake pressure is built up more quickly. | TL | CL |



Electronic Stabilisation Programme. It prevents under- or over-steering via targeted braking of individual wheels. | TL | CL |



Traction Control System (TCS). Prevents wheelspin. | TL | CL |



Electronic Differential Lock (EDL). Distributes the engine torque to the tyres without slippage. | TL | CL |



Hill Start Assist. Prevents the vehicle from rolling off on inclines and makes handling easier when starting off on uphill slopes. | TL | CL |



Daytime Running Lights. Switch on automatically when the ignition is activated and lower the risk of an accident in daylight. | TL | CL |



Cruise Control incl. speed limiter. As of a speed of 30 km/h, it maintains the desired speed depending on uphill and downhill inclines or limits the top speed to a value selected by the driver. | TL | CL |



Seat Belt Warning. If their seat belts are not fastened, the seat belt warning reminds the driver and, for the first time, the front passenger to fasten their belts with a visual warning when the engine is started, and an acoustic warning after setting off. | TL | CL |



Multi-Collision Braking System. Triggers braking after a collision, with the aim of preventing secondary collisions. The Multi-Collision Braking System activates when two independent sensors detect an accident. After a short delay, the vehicle begins a phased braking action down to 10 km/h, during which the driver can take over at any time. | TL | CL |



Airbags. The Caddy comes with driver and front passenger airbags as standard, and side/head airbags too. Also standard are head airbags to protect rear passengers in the outer seats of the second seating row in the event of a side-on collision. | TL | CL |

*Safety technologies are designed to assist the driver, but should not be used as a substitute for safe driving practices.



01 Rear Park Distance Control*. Emits audible warnings when obstacles are detected behind the vehicle when parking, and also provides a visual display of the vehicle's distance from the obstacles (Discover Media shown). | TL | CL |



02 Rear View Camera*. Simplifies parking by showing a limited view of the area behind the vehicle on the display of the radio or navigation system. Additional static guidelines facilitate the parking process (Discover Media shown). | TL | CL |



Adaptive Cruise Control ACC*. Automatically adapts the vehicle's speed to that of the vehicle driving in front and maintains the distance set by the driver. At the same time, it remains within the set speed. Only with Driver Assistance Package I. | TL | CL |

"Front Assist" ambient traffic monitoring system with City Emergency Braking System*. Uses a radar system to detect situations where the distance to the vehicle in front is critical, and reduces the vehicle's stopping distance. In dangerous situations, the system alerts the driver by means of visual and acoustic signals, and with a warning jolt of the brakes. Only with Driver Assistance Package I. | TL | CL |



"Park Assist" parking steering assistance*. Handles multi-step parking into parallel and bay parking spaces. When the reverse gear is engaged, the vehicle automatically assumes control of the steering. All the driver has to do is operate the clutch, accelerator, and the brake. Only with Drivers Assistance Package II. | TL | CL |

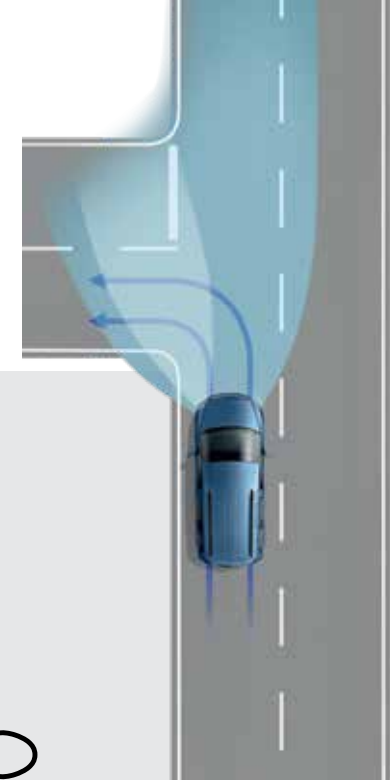

Fog lights with integrated static cornering light. Ensures optimal visibility in poor weather conditions. The headlight nearest to the corner illuminates the roadside when turning. Only with Drivers Assistance Package I. | TL | CL |

*Safety technologies are designed to assist the driver, but should not be used as a substitute for safe driving practices.

Economical fuel consumption.
Powerful driving.

Advanced petrol engine.

Caddy's 1.4L TSI220 engine delivers 92kW of power and is fitted with BlueMotion Technology as standard. The combination of direct injection and turbocharging makes this engine smooth, efficient and, despite the low cylinder capacity, very powerful.

Power transmission to the front wheels is the task of the smooth-running dual clutch gearbox DSG gearbox.





Reduced fuel consumption thanks to BlueMotion Technology.

Volkswagen models with BlueMotion Technology are in line with the "Think Blue" concept: to develop fuel-efficient vehicles that place less burden on the environment over their entire lifetime. That is why every Caddy is equipped with a start/stop system and regenerative braking.

Start/stop system. The system helps you to drive economically, and switches off the engine when you come to a stop. This can reduce fuel consumption especially in urban traffic or stop-and-go situations.

Regenerative braking (recuperation). Frictional energy is stored during braking, and converted into electrical energy by a generator. This is then stored in the car battery and available for electricity consumption.

Specifications and weights

Engine	
Type	1.4 litre TSI220 BlueMotion Technology 4 cylinder inline turbocharged direct injection petrol with engine Start/Stop system [^]
Max power, kW @ rpm	92 @ 4,800
Max torque, Nm @ rpm	220 @ 1,500-3,500
Cubic capacity, litres/cc	1,395
Bore/stroke, mm	74.5 x 80
Compression ratio	10.5 : 1
Fuel type (recommended)	Premium unleaded 95 RON minimum
Transmission	
Driven wheels	7 Speed Direct Shift Gearbox (DSG) with sport mode and Tiptronic function Front Wheel Drive
Fuel consumption**	
Combined, L/100km	6.0
Urban, L/100km	7.0
Extra Urban, L/100km	5.4
Fuel tank capacity, L	55

Weights	Trendline	Maxi Trendline	Maxi Comfortline
Gross Vehicle Weight (GVM), kg	2,280	2,280	2,280
Unladen Mass ¹ , kg	1,455	1,563	1,586
Roof Load (kg)	100	100	100
Towing Capacity, kg[‡]			
Braked	1,300	1,300	1,300
Unbraked	630	630	630
Trailer Load Limit, kg	100	100	100

Wheels



16" steel wheel
with full wheel cap.
Standard for Trendline



16" alloy wheel - BENDIGO.
Standard for Comfortline
Optional for Trendline



17" alloy wheel - ROCKHAMPTON.
Optional for Comfortline.

Full vehicle specifications are available at www.volkswagen.com.au

[^]The Start/Stop system is designed to reduce fuel consumption and CO2 emissions. It achieves this by automatically switching off the engine while the vehicle is stationary and then starting it again automatically when the driver wants to drive off. There are certain operating conditions where the Start/Stop system is deactivated (e.g. during engine warm-up), please refer to the owner's manual for full operating information.

**Fuel consumption figures according to ADR 81/02 derived from laboratory testing. Factors including but not limited to driving style, road and traffic conditions, environmental influences, vehicle condition and accessories fitted, will in practice in the real world lead to figures which generally differ from those advertised. Advertised figures are meant for comparison amongst vehicles only.

1. The Unladen Mass (UM) includes 10L of fuel, vehicle fluids and no occupants. Figures quoted are for base model vehicles only.

[‡] When fitted with Volkswagen Genuine Tow Bar. Towing capacities are applicable to Volkswagen Genuine Accessory Tow Bar. Towing capacity figures are maximum figures and actual towing capacity depends on factors including the laden mass of the vehicle, driving conditions and fitment of any accessories. Volkswagen Group Australia does not endorse or will not be held liable for any claim, loss or damage arising from the use or fitment of electronic trailer brakes.

Dimensions and capacities

Dimensions	Trendline	Maxi Trendline	Maxi Comfortline
Seating capacity	5 (2 + 3) Optional: 7 (2 + 3 + 2)	7 (2 + 3 + 2)	7 (2 + 3 + 2)
Cargo Volume (L) - behind 1st row	3,030	3,880	3,880
Cargo Volume (L) - 2nd row folded forward (without 3rd row)	2,852	3,700	3,700
Cargo Volume (L) - behind 2nd row	750	1,350	1,350
Cargo Volume (L) - behind 3rd row (if fitted)	190	530	530
Sliding Door Width (mm)	701	701	701
Sliding Door Height (mm)	1,086	1,086	1,086
Tailgate Width (mm)	1,183	1,183	1,183
Tailgate Height (mm)	1,127	1,127	1,127
Load Sill Height (mm)	575	581	581
Turning Circle (m)	11.1	12.2	12.2

Caddy Trendline

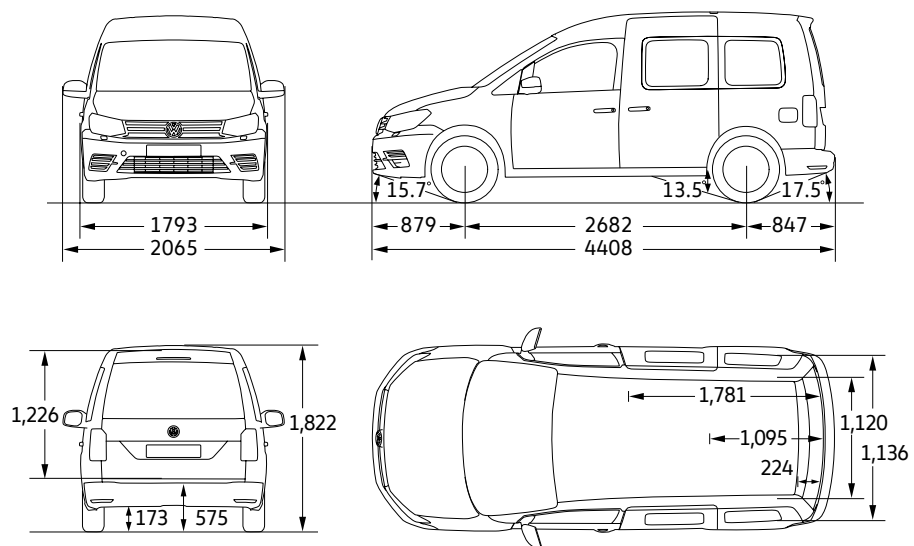

Caddy Maxi Trendline and Maxi Comfortline

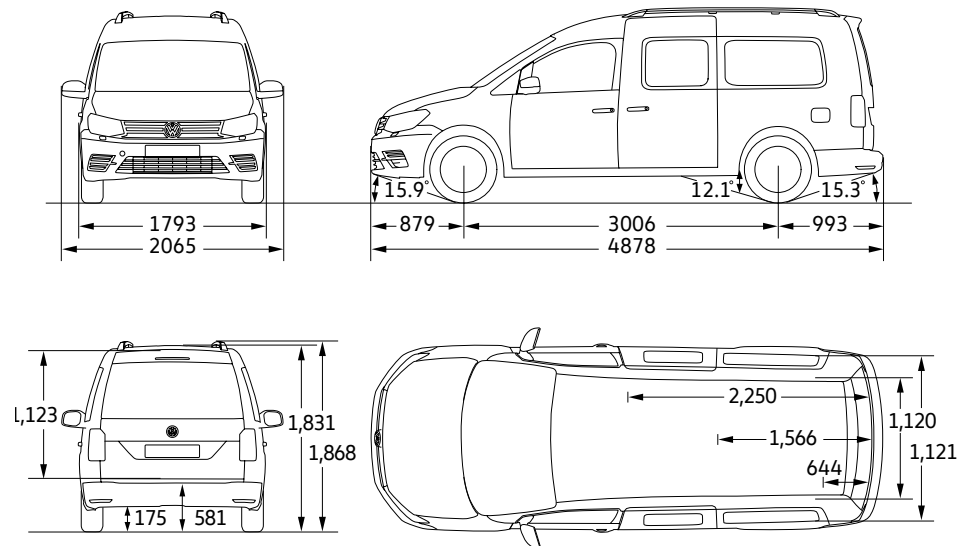

Roof rails shown for Comfortline model only.

Volkswagen Accessories.

The Caddy people mover is a highly versatile vehicle that leaves nothing to be desired. If you would like to have a few extras, Volkswagen Accessories offers interesting additional equipment options. These have been developed in cooperation with our Development and Design department, provide top quality, and are only available at your Volkswagen dealer. So everything fits nicely together.

01 Loading sill protection plate.

02 Towbar.

03 Mudflaps.

04 Roof bars.

05 Rubber floor mats.

06 Slimline weathershields.



Please note that the above accessories may have an effect on fuel efficiency. Overseas models are shown for illustrative purposes only. For a full range of genuine accessories please refer to the model specific accessories tab at www.volkswagen.com.au

Solid paint finishes



Candy White | Solid paint finish | B4B4



Cherry Red | Solid paint finish | 4B4B

Metallic and Pearlescent finishes



Reflex Silver | Metallic paint finish | 8E8E



Mojave Beige | Metallic paint finish | 1B1B



Indium Grey | Metallic paint finish | X3X3



Chestnut Brown | Metallic paint finish | H4H4



Deep Black | Pearl effect paint finish | 2T2T



Acapulco Blue | Pearl effect paint finish | 2W2W



Starlight Blue | Metallic paint finish | 3S3S



Bamboo Garden Green | Metallic paint finish | 3T3T



Sandstorm Yellow | Metallic paint finish | 9U9U



Fortana Red | Metallic paint finish | 1919

Decorative trims & Seat upholstery



Dark Silver Brushed | TL |

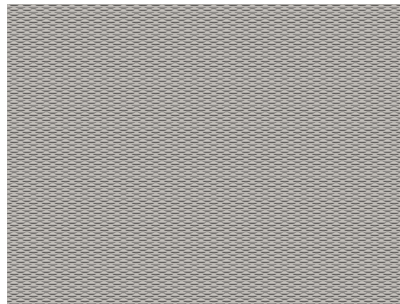

Checker Plate Titan | CL |



Kutamo | Cloth seat upholstery | Moonrock Titanium Black | TL |



Panduro | Cloth seat upholstery | Titanium Black | CL |

Please note that Cherry Red solid, Metallic and Pearl Effect paint are optional at extra cost. The print process does not allow for exact reproduction of the exterior or the upholstery colours. Please contact your Volkswagen Dealer for further information on colours and upholstery combinations. Overseas models shown.

Volkswagen Choice: Protecting your investment

We're out to prove that there still are some guarantees in life. We've developed Volkswagen Choice[^] - a flexible finance solution that provides you with the assurance of knowing exactly what the minimum value of your vehicle will be down the track. With Volkswagen Choice[^], you can enjoy your car without worrying about what the future will bring, providing peace of mind.

Volkswagen Choice

Guaranteed Future Value

Step 1

Choose your favourite Volkswagen model.

Step 2

Choose your preferred term from between 12 and 48 months, along with an annual km allowance and repayment options that suit your lifestyle.

Step 3

At the end of your chosen term, select from one of the three below end of term options:



Trade in

If you wish to trade-in your Volkswagen for a new vehicle, all you need to do is return it to the dealership. If the trade-in value is higher than the Guaranteed Future Value[^], you can use this equity towards your new vehicle purchase.



Retain

If you prefer to retain your Volkswagen, simply let us know. Provided that you also meet the relevant payment obligations under your contract, you can purchase your vehicle outright for the Guaranteed Future Value price locked in at the start of the contract[^]. Then your Volkswagen is yours to keep. Or you can choose to refinance your balloon at the end of the term.



Return

Return your vehicle and, if it meets the agreed kilometre and fair wear and tear requirements[^], you will have no more to pay.



To find out more, go to <https://www.volkswagen.com.au/en/financial-services/guaranteed-future-value.html>

[^]The Volkswagen Choice Program consists of an option to return the vehicle to Volkswagen Financial Services (VFS)** at the end of the term and require VFS** to purchase the vehicle at an agreed price known as the Guaranteed Future Value or GFV as determined by VFS** and set out in your contract. At the end of the term, you can elect to: (1) trade-in the vehicle; (2) exercise the option to return the vehicle; or (3) retain the vehicle by paying the GFV, which is a lump sum owed to VFS** at the end of the loan term after all monthly repayments have been made. Available on new and demonstrator Volkswagen vehicles for selected models only. Verify with dealership eligible vehicles for the program. The GFV will be reduced, and you will be liable for any loan contract deficit, if you exceed the nominated kilometre allowance and/or the vehicle is not in an acceptable condition. Standard fees/charges and further conditions apply, available from VFS**. Only available to approved applicants of VFS** at participating Volkswagen dealers. Fleet, government, rental buyers, hire car and chauffeur companies excluded.

**VFS is a trading name of Volkswagen Financial Services Australia Pty Limited ABN 20 097 071 460, Australian Credit Licence Number 389344.

The Caddy

Volkswagen Group Australia Pty Ltd
24 Muir Road Chullora NSW 2190
ABN 14 093 117 876

Printed in Australia
October 2018
www.volkswagen.com.au

Publication: VWCCADPEOMY19

Important information

Apple CarPlay® is a registered trade mark of Apple Inc. Android Auto™ is a registered trade mark of Google Inc. MirrorLink® is a registered trade mark of Car Connectivity Consortium LLC. Bluetooth® is a registered trade mark of Bluetooth SIG Inc.

Volkswagen is distributed by Volkswagen Group Australia Pty Ltd (ABN 14 093 117 876) of 24 Muir Road Chullora, NSW 2190. Specifications are as planned at October 2018, for Model Year 2019 and are subject to change without notice or obligation. All information in this brochure are correct at the time of publication, however variations may occur from time to time and Volkswagen, in so far as it is permitted by law to do so, shall not be liable in any way as a result of any reliance by any person on anything contained in this brochure. Authorised Volkswagen Dealers will provide up-to-date information on model application, design feature, prices, and availability on request.

Your Volkswagen Dealer.