

GMC 2017 TERRAIN





TERRAIN DENALI IN EBONY TWILIGHT METALLIC (left)
TERRAIN SLT IN CRIMSON RED TINTCOAT (centre)
TERRAIN SLE-2 IN QUICKSILVER METALLIC (right)
Vehicles shown with available equipment.

DENALI | 2

SLT | 6

NIGHTFALL | 8

PERFORMANCE | 14

PROTECTION | 16

SELECTION | 20

PRECISION MATTERS

It matters in every pound-foot of torque, every millimetre of fit and finish and every decibel of quiet. It drives us to reimagine solutions and create rewarding driving experiences. That's why the new 2017 Terrain is a testament to design and engineering. More innovations per square inch mean you get full-size capability in a smart, connected crossover.



DENALI

REFINING THE REFINEMENTS.

Looking at the new 2017 Terrain Denali, it's easy to see why it's the ultimate Terrain. With its signature Denali grille and bold styling, satin-chrome door handles, mirror caps, bodyside mouldings and Denali-exclusive wheels, it takes the crossover to an enhanced level of premium. After all, at GMC, precision means more than premium refinement—it means precision design, engineering and craftsmanship.

+ SIGNATURE DENALI GRILLE

+ BOLD EXTERIOR DESIGN WITH UNIQUE DENALI WHEELS

+ PROJECTOR-BEAM HEADLAMPS

+ PROGRAMMABLE POWER LIFTGATE

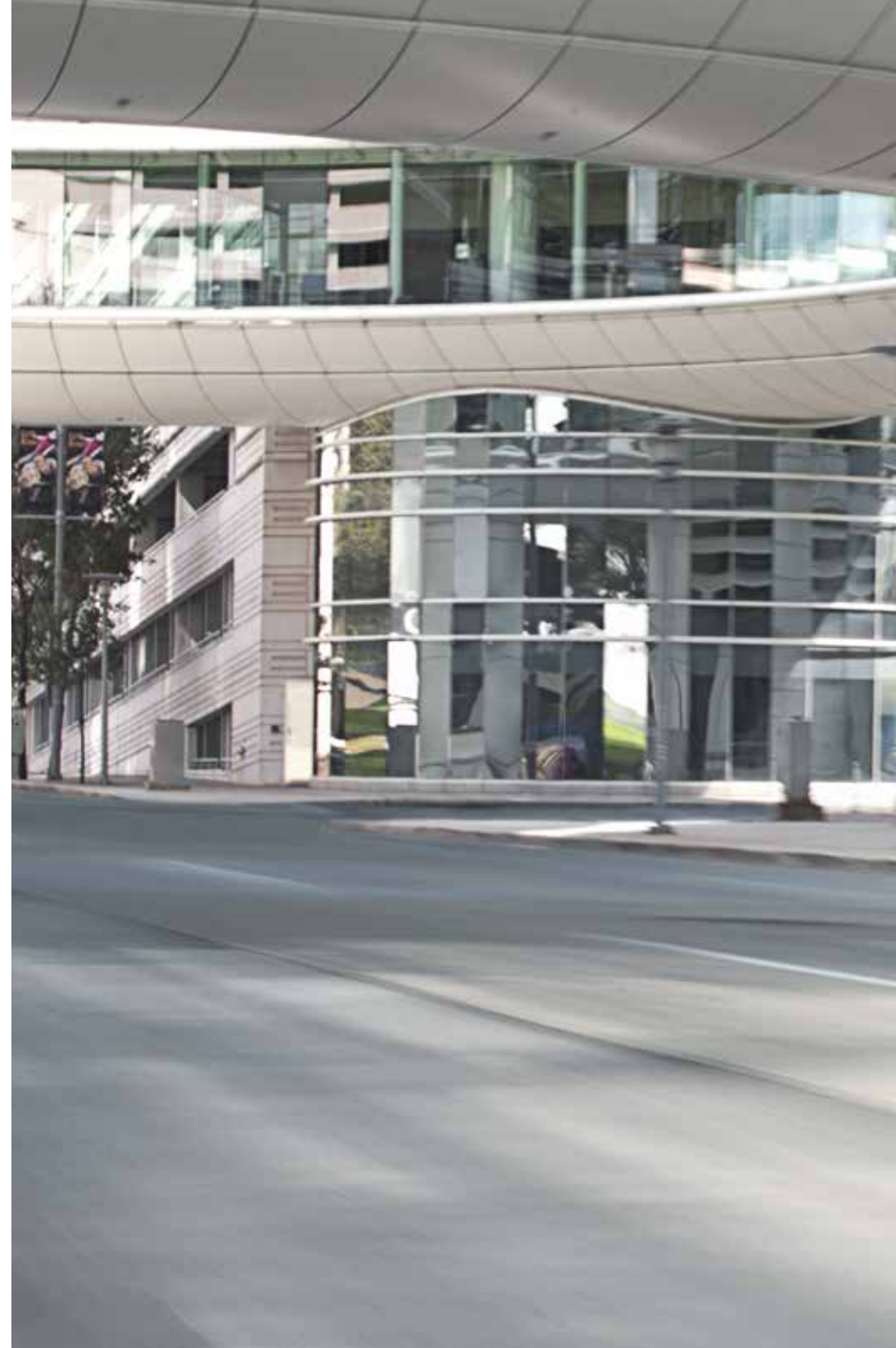



TERRAIN DENALI IN EBONY TWILIGHT METALLIC
shown with available equipment.

P. 3 | DENALI | EXTERIOR

PREMIUM MEASURED IN STITCHES- PER-INCH AND COMFORT-PER-MILE.

Open the door to Terrain Denali and discover the result of a lot of thinking—about you. To enhance your comfort, convenience and driving experience, GMC designers ensured that style and practicality are equally represented. A generous stitches-per-inch ratio results in a detailed, premium appearance. Denali also elevates all of your tactile, visual and auditory senses. Professional Grade engineering and exacting execution are what we demand of ourselves, because it's what precision demands. Here's proof:

+ DISTINCTIVE DENALI LEATHER-APPOINTED SEATING

+ HEATED FRONT EIGHT-WAY POWER SEATS

+ GENEROUS SECOND-ROW LEG ROOM

+ POWER TILT-SLIDING SUNROOF



+

+



TERRAIN DENALI INTERIOR IN JET BLACK
shown with available equipment.

P. 5 | DENALI | INTERIOR

SLT

OUR SCULPTORS WORK IN SHEET METAL.

The GMC design philosophy is to create styling that doesn't simply look good; it also must be purposeful. From the angle of the windshield to every line and curve, the whole idea is to disturb less air. That's why Terrain is designed to slice the wind to help create a quiet driving environment. SLT offers additional features that will catch your attention.

+ DISTINCTIVE DIMENSIONAL GRILLE

+ TRIPLE DOOR SEALS

+ 18" ALUMINUM WHEELS

+ CHROME-ACCENTED MIRROR CAPS, DOOR HANDLES AND LUGGAGE RAILS

+ LED DAYTIME RUNNING LAMPS





TERRAIN SLT IN ONYX BLACK
shown with available equipment.

P. 7 | SLT | EXTERIOR

NIGHTFALL EDITION

DESIGNED FOR ANY OCCASION.

The new available Nightfall Edition is the perfect look for any occasion. Its stylish appearance comes from a charcoal grille with gloss-black surround and accents, gloss-black mirror caps, gloss-black licence plate trim and charcoal luggage rails. Terrain's bold, iconic design now has a dark side. The Nightfall Edition also includes:

- + 18" ALUMINUM WHEELS WITH GLOSS-BLACK ACCENTS
- + PIONEER® PREMIUM SOUND SYSTEM
- + BODY-COLOUR DOOR HANDLES
- + PROGRAMMABLE POWER LIFTGATE (AVAILABLE ON SLT)
- + GLOSS-BLACK FRONT AND REAR ACCENTS
- + INTELLILINK¹ COLOUR TOUCH RADIO
- + REAR VISION CAMERA
- + NAVIGATION SYSTEM² (AVAILABLE)
- + LED DAYTIME RUNNING LAMPS
- + 4G LTE WI-FI³ HOTSPOT

¹Full functionality requires compatible Bluetooth® and smartphone, and USB connectivity for some devices. Visit intellilink.gmc.gm.ca for more details. ²At time of printing, detailed map coverage is available for most major urban areas of the United States and for certain metropolitan areas of Canada (Vancouver, Calgary, Edmonton, Winnipeg, Windsor, London, Toronto, Ottawa, Montreal, Quebec City and Halifax). Coverage is significantly limited outside these areas. ³Visit onstar.ca for coverage maps, details and system limitations. Available 4G LTE Wi-Fi requires compatible mobile device, active OnStar service and data plan. Services vary by model, conditions and geographical and technical restrictions. OnStar with 4G LTE connectivity is available on select vehicle models and in select markets. OnStar acts as a link to existing emergency service providers. Not all vehicles may transmit all crash data. After the trial period (if applicable), an active OnStar service plan is required.





TERRAIN NIGHTFALL EDITION IN ONYX BLACK
shown with available equipment.

P. 9 | NIGHTFALL | EXTERIOR

DETAILS. DETAILS. DETAILS.

The proportions of Terrain were crafted with a clear understanding of what you look for in a crossover. This is a design that turns an abundance of bold details into a whole new take on the crossover. Terrain provides generous space and many ways for you to tailor its comfort and storage to fit your needs and lifestyle.



DENALI GRILLE Terrain Denali features a satin-chrome grille with a bright surround, giving it a distinctive appearance.



PROJECTOR-BEAM HEADLAMPS Terrain provides bright, focused illumination for confident visibility with integral projector-beam headlamps. For daytime illumination, Terrain offers available LED daytime running lamps for excellent visibility and durability.



ALUMINUM WHEELS Terrain Denali models offer two aluminum wheel choices: 18" chrome-clad wheels with the standard I-4 and 19" ultra-bright machined aluminum wheels with the available V6 engine.



ACOUSTIC LAMINATED GLASS The windshield is engineered with acoustic laminated glass to help keep road noise from entering the cabin.



TRIPLE DOOR SEALS Airtight door seals on all four doors not only help suppress unwanted road noise, but also minimize air leaks for a quieter interior.



PROGRAMMABLE POWER LIFTGATE Terrain offers an available programmable power liftgate. It opens and closes with the touch of a button to the programmed height.



DISTINCTIVE DENALI APPOINTMENTS Contrasting stitching outlines perforated leather-appointed seating, with an embossed Denali logo on the front seats.



COMFORTABLE SEATING Standard on Denali and available on SLT, both the driver and front passenger enjoy the comfort of an eight-way power seat with power lumbar. And to help warm you up quickly, available front heated seats can be activated when you use the available remote vehicle starter system.



STORAGE The interior features an oversized glove box in addition to the centre console that's deep enough for a laptop or tablet. There's a storage shelf under the radio, a smaller compartment under the centre armrest and two-tier storage in the door panels.



ACOUSTICS AND NOISE SUPPRESSION The windshield angle, body shape and mirrors are designed to help manage airflow to reduce wind noise.



LOW ACCESS HEIGHT The floor is at a lower, car-like height, making it easy to enter and exit as well as load large or heavy items. With the second-row seats folded down, Terrain provides up to 1809 litres of available cargo space.¹



AMBIENT LIGHTING The centre stack is illuminated with warm, red ambient lighting.

¹Cargo and load capacity limited by weight and distribution.

THE INTERNET-AS MOBILE AS YOU ARE.

Terrain offers all the technology you need to stay connected, entertained and mobile. Offering 4G LTE connectivity and a Wi-Fi hotspot,¹ now you can stay connected to your world.



 **4G LTE WI-FI¹** This built-in 4G LTE Wi-Fi hotspot means a reliable Internet connection for up to seven devices.² It's powerful, easy to use and can connect up to 15 metres away from Terrain. Includes a 3-month or 3 GB trial, whichever comes first.

INTELLILINK³ Standard on SLE-2, SLT and Denali, IntelliLink provides smartphone integration and voice-activated control of your communication and entertainment selections. This includes making a call, changing the station, streaming Internet radio⁴ through your smartphone or accessing your music library.



NAVIGATION SYSTEM⁵ The available NAV system, which includes IntelliLink,³ adds multiple map views. It also features 3 months of NavTraffic,⁶ so you'll get continuously updated traffic information incorporated into the Navigation System.



REMOTE VEHICLE STARTER SYSTEM

Start and warm the cabin to your preset temperature from up to 60 metres away when equipped with this available feature. SLE-2, SLT and Denali models can begin heating or cooling the interior based on exterior temperature, and also turn on heated seats, the rear defogger and exterior heated side-view mirrors.



USB CONNECTIVITY⁷ Plug into the USB port and control most of your MP3 music player's functions with available steering-wheel-mounted audio controls.

PIONEER PREMIUM SOUND

The available Pioneer system allows you to hear your favourite music as the artist intended. With the help of eight strategically placed speakers, this available sound system fills the interior with 250 watts of premium sound.



STEERING-WHEEL-MOUNTED CONTROLS

Change stations, adjust volume or search the audio system with your fingertips. Also included are Bluetooth⁷ controls.

⁷Visit onstar.ca for coverage maps, details and system limitations. Available 4G LTE Wi-Fi requires compatible mobile device, active OnStar service and data plan. Services vary by model, conditions and geographical and technical restrictions. OnStar with 4G LTE connectivity is available on select vehicle models and in select markets. OnStar acts as a link to existing emergency service providers. Not all vehicles may transmit all crash data. After the trial period (if applicable), an active OnStar service plan is required. ⁸Devices must be WPA2-compliant with an active OnStar service plan and data plan. Wi-Fi devices manufactured prior to 2006 may not be compatible. Please consult your device manufacturer for information regarding the WPA2 security protocol and Wi-Fi device compatibility. Vehicle must be started or in accessory mode to access Wi-Fi. Visit onstar.ca for system details and limitations. ⁹Full functionality requires compatible Bluetooth and smartphone, and USB connectivity for some devices. Visit intellilink.gmc.gm.ca for more details. ⁴Data plan rates apply. ⁵At time of printing, detailed map coverage is available for most major urban areas of the United States and for certain metropolitan areas of Canada (Vancouver, Calgary, Edmonton, Winnipeg, Windsor, London, Toronto, Ottawa, Montreal, Quebec City and Halifax). Coverage is significantly limited outside these areas. ⁶Available in 10 Canadian provinces and the 48 contiguous United States. Subscription sold separately after trial period. If you decide to continue your service at the end of your trial subscription, the plan you choose will automatically renew and bill at then-current rates until you call 1-877-209-0079 to cancel. Other fees and taxes will apply. All fees and programming subject to change. See SiriusXM "Terms & Conditions" and complete details at siriusxm.ca. ⁷Not compatible with all devices.

PERFORMANCE

ROADS. WEATHER. EFFICIENCY. CONSIDER THEM HANDLED.

Terrain's precision engineering allows you to handle the unexpected. With traction control and available all-wheel drive, even when road and weather conditions turn challenging, you're still in command. Terrain offers two sources of power: The 2.4L I-4 is standard, and with front-wheel-drive models, it offers 7.5 L/100 km hwy,¹ or there's the available 3.6L V6 that generates 301 hp with 9.7 L/100 km hwy.¹

RACK-MOUNTED POWER STEERING On 2.4L models, the system delivers assist electronically, eliminating the need for a power-steering pump. It gives you a steering boost when you need it for parking and tight manoeuvres.

6-SPEED AUTOMATIC WITH OVERDRIVE For brisk acceleration and reduced highway rpm, this advanced transmission has a wide ratio spread for strong, consistent acceleration at almost any speed.

ALL-WHEEL DRIVE (AWD) An intelligent AWD system is available for extra traction and the ability to adapt to changing road conditions.

TRACTION CONTROL Making the most of available traction, it senses when one or more wheels is spinning, such as on slippery surfaces, and applies the brakes and slows the wheel(s) down to maintain traction.

ADVANCED DUAL-FLOW VALVING This feature in Terrain Denali's front suspension provides a smoother ride and improved handling across a broad range of driving conditions.

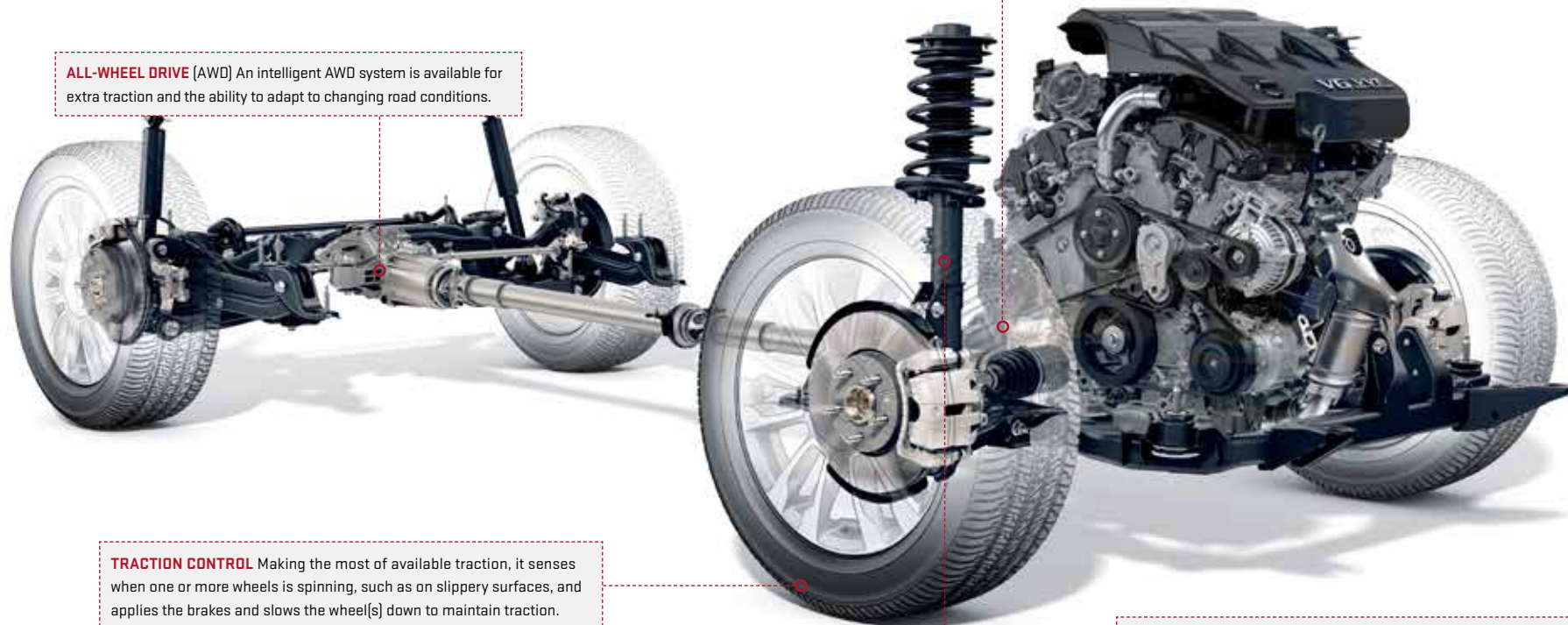

¹Fuel-consumption estimates based on GM preliminary testing in accordance with Government of Canada approved test methods. Refer to vehicles.nrcan.gc.ca for details. Your actual fuel consumption may vary.

301 HP

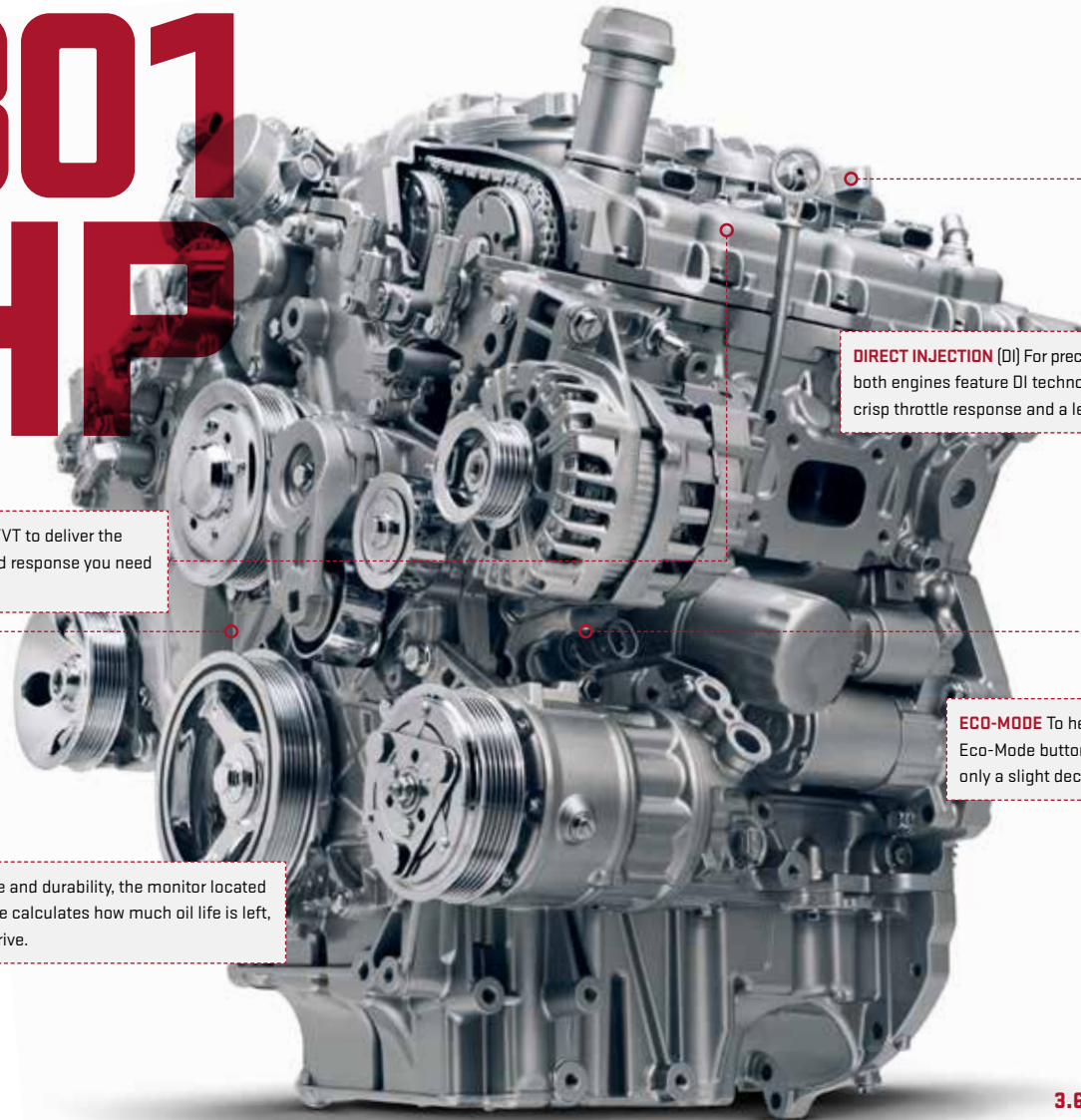

VARIABLE VALVE TIMING (VVT) Both engines feature VVT to deliver the power of a high-performance engine with the low-speed response you need for trailering or climbing steep inclines.

DIRECT INJECTION (DI) For precise fuel distribution and fast, efficient combustion, both engines feature DI technology. The air and fuel mix more completely for crisp throttle response and a lean blend for efficiency at cruise speeds.

ECO-MODE To help optimize efficiency, the 2.4L I-4 engine has an Eco-Mode button that allows the engine to hold gears longer, with only a slight decrease in acceleration.

OIL LIFE MONITOR For long life and durability, the monitor located in the Driver Information Centre calculates how much oil life is left, based on when and how you drive.

3.6L V6

PROTECTION

INSTEAD OF WHAT IF, WHAT IF IT DIDN'T HAPPEN?

To help increase your awareness of surrounding traffic, Terrain offers intuitive driver-assist technologies. They're constantly on guard, ready to help you through adverse driving conditions. Safety features are no substitute for the driver's responsibility to operate the vehicle in a safe manner. The driver should remain attentive to traffic, surroundings and road conditions at all times. Read the vehicle Owner's Manual for more important safety information.

REAR PARK ASSIST Available Rear Park Assist uses ultrasonic sensors to help alert you when you may be approaching obstacles behind Terrain at low speeds.

SIDE BLIND ZONE ALERT AND REAR CROSS TRAFFIC ALERT Available Side Blind Zone Alert¹ uses radar to monitor blind spots, alerting you to vehicles in adjacent lanes to help reduce the risk of a collision. While in reverse, the available Rear Cross Traffic Alert system alerts you to vehicles approaching from the left or right.

LATCH CHILD SEAT ANCHORING SYSTEM Lower Anchors and Top tethers for CHILDren (LATCH) enables a child seat top tether strap to be attached to limit movement in a forward crash, helping reduce the chance of injury.



¹Before making a lane change, always check the Side Blind Zone Alert display, check the exterior and interior rear-view mirrors, look over your shoulder for vehicles and hazards and start the turn signal. ²Always use safety belts and the correct restraint for your child's age and size. Even in vehicles equipped with the Passenger Sensing System, children are safer when properly secured in a rear seat in the appropriate infant, child or booster seat. Never place a rear-facing infant restraint in the front seat of any vehicle equipped with a passenger airbag. See the Owner's Manual and child safety seat instructions for more safety information.

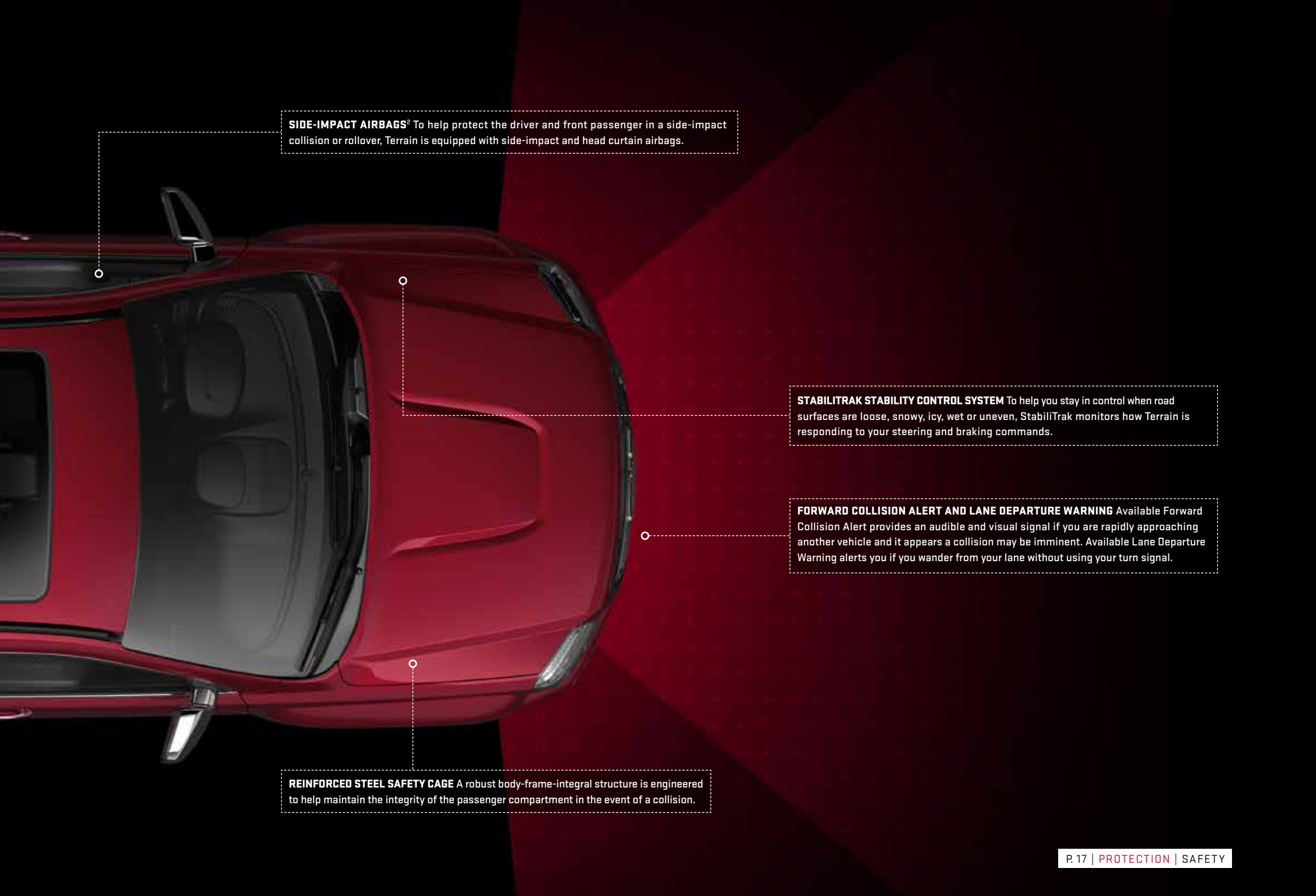

SIDE-IMPACT AIRBAGS² To help protect the driver and front passenger in a side-impact collision or rollover, Terrain is equipped with side-impact and head curtain airbags.

STABILITRAK STABILITY CONTROL SYSTEM To help you stay in control when road surfaces are loose, snowy, icy, wet or uneven, StabiliTrak monitors how Terrain is responding to your steering and braking commands.

FORWARD COLLISION ALERT AND LANE DEPARTURE WARNING Available Forward Collision Alert provides an audible and visual signal if you are rapidly approaching another vehicle and it appears a collision may be imminent. Available Lane Departure Warning alerts you if you wander from your lane without using your turn signal.

REINFORCED STEEL SAFETY CAGE A robust body-frame-integral structure is engineered to help maintain the integrity of the passenger compartment in the event of a collision.

ACCESSORIES

THE ICING.

Available individually or as part of a package, GMC Accessories are the best way to take Terrain's iconic design and add your own personal style.

+ ROOF RACK CROSS RAIL PACKAGE

+ EXTERIOR REAR-VIEW MIRROR COVERS

+ TRAILERING EQUIPMENT PACKAGE

+ MOULDED SPLASH GUARDS

+ TABLET HOLDER

+ CHROME DOOR HANDLES

+ CARGO-AREA ALL-WEATHER FLOOR MAT

+ CARGO SECURITY SHADE

+ CARGO NET

+ CARGO-AREA CLOSE-OUT PANEL

+ CARGO ORGANIZER

+ CHROME FUEL DOOR

+ PROTECTION PACKAGE

+ CARGO CONVENIENCE PACKAGE (VQR)



WE'RE AS CLOSE AS THE BLUE BUTTON.



Standard for 6 months, the OnStar Guidance Plan (trial excludes Hands-Free Calling minutes) lets you connect to an OnStar Advisor just by pushing the blue OnStar button in your Terrain.

 **4G LTE WI-FI¹** Terrain has a built-in Wi-Fi hotspot for connecting up to seven tablets, laptops or other devices² at fast speeds, so the content you crave is always headed where you are. Requires a data plan after the 3-month or 3 GB data trial (whichever comes first).

ONSTAR BASIC PLAN³ With the Basic Plan, you've got a powerful connection to your vehicle and the world around you standard for 5 years at no additional cost to you. You'll have access to select services, which include limited features of the myGMC mobile app⁴ that lets you remote-start your vehicle (if equipped) and manage your vehicle's Wi-Fi hotspot (if equipped). Plus, lock or unlock your doors—all from your mobile device. Your vehicle can run diagnostic checks on itself and remind you of servicing needs by email.

AUTOMATIC CRASH RESPONSE Depending on the severity of the crash, built-in sensors may automatically alert an OnStar Advisor who is immediately connected into your vehicle to see if you need help—even if you can't ask for it.

EMERGENCY SERVICES One push of the red emergency button gives you a priority connection to a specially trained OnStar Advisor who can direct emergency services to your exact location and offer critical assistance until help arrives. With OnStar, you're never alone.

CRISIS ASSIST During severe weather or other crisis situations, OnStar can provide a quick, central point of contact when you need emergency assistance, navigation help or information.

ROADSIDE ASSISTANCE⁵ If you're stranded, have a flat tire or need a tow truck, just ask an OnStar Advisor to get help to your exact location to get you back on the road quickly.

STOLEN VEHICLE ASSISTANCE⁶ If your vehicle is stolen, OnStar can work with authorities and use GPS to pinpoint and quickly help recover it. On many models, an Advisor can send a signal to slow the vehicle or prevent it from being started. And with the new Theft Alarm Notification⁷ feature, if your car alarm sounds, you'll receive a notification by text, email or phone call.

TURN-BY-TURN NAVIGATION⁸ Getting directions is as easy as pushing a button and telling an Advisor where you want to go. Directions are quickly downloaded to your vehicle, and a voice calls out every turn. An Advisor can also help you with a database of more than 1 million points of interest. To plan routes in advance, you can send destinations to your vehicle through an Advisor or the myGMC mobile app.⁴

myGMC MOBILE APP⁴ You can remotely start your vehicle, lock or unlock your doors, honk your horn and flash your lights. You can also send destinations to your vehicle through your smartphone.

REMOTE SERVICES⁹ A simple call to an OnStar Advisor can send a signal to unlock your doors or honk the horn and flash the lights. It's technology hard at work to get you back on the road.

HANDS-FREE CALLING¹⁰ Your vehicle has built-in Hands-Free Calling to help keep you safely connected when your cellphone isn't easily accessible. Choose from minute bundles or a minutes-per-month plan.

ATYOURSERVICE Life just got easier and more affordable with the personalized connection of AtYourService. By simply pressing the blue OnStar button, our trusted Advisors can help you locate hotels and even book your room through Priceline.¹¹

ADVANCED DIAGNOSTICS¹² Feel confident and safe knowing you have a self-diagnosing vehicle. Now your vehicle can easily run a check on its key systems and send you a monthly Diagnostics Report email. You'll know more and worry less with Advanced Diagnostics.

DEALER MAINTENANCE NOTIFICATION Is it time for a tire rotation? An oil change? Or a new air filter? You'll always know because your vehicle can email your Diagnostics Report to the dealer when it's time, and the dealer will contact you to set up a service appointment.



¹Visit onstar.ca for coverage maps, details and system limitations. Available 4G LTE Wi-Fi requires compatible mobile device, active OnStar service and data plan. Services vary by model, conditions and geographical and technical restrictions. OnStar with 4G LTE connectivity is available on select vehicle models and in select markets. OnStar acts as a link to existing emergency service providers. Not all vehicles may transmit all crash data. After the trial period (if applicable), an active OnStar service plan is required. ²Devices must be WPA2-compliant with an active OnStar service plan and data plan. Wi-Fi devices manufactured prior to 2006 may not be compatible. Please consult your device manufacturer for information regarding the WPA2 security protocol and Wi-Fi device compatibility. Vehicle must be started or in accessory mode to access Wi-Fi. Visit onstar.ca for system details and limitations. ³The OnStar Basic Plan is available for 5 years from the date of delivery of the eligible new 2015 model year and newer vehicles and is transferable to subsequent owners for the remaining term. The Basic Plan includes access to: (1) monthly Diagnostics Report emails [capabilities vary by model]; (2) Dealer Maintenance Notification; and (3) limited myGMC mobile app services, which include remote start [requires factory-installed and enabled remote-start system], remote lock/unlock doors [requires automatic locks] and remote horn and lights activation. The myGMC mobile app is available on select Apple, Android, BlackBerry and Windows devices. Visit onstar.ca for vehicle availability, coverage map, details and system limitations. The OnStar Basic Plan does not include any Emergency Services, Automatic Crash Response, Stolen Vehicle Assistance, live Advisor service or Hands-Free Calling. These and other services are available under a paid plan. If you sell your vehicle or wish to cancel use of Basic Plan services, you must contact OnStar at 1-888-4-ONSTAR [1-888-466-7827]. ⁴Available on select Apple, Android, BlackBerry and Windows devices. Requires an active OnStar service plan. Services vary by device, vehicle, conditions and the type of service plan you have. Please visit onstar.ca for vehicle availability, system limitations, geographical and technical restrictions and further details. ⁵Roadside service provided by Allstate Roadside Services. ⁶Services vary by model, conditions and geographical and technical restrictions. Visit onstar.ca for details and system limitations. Stolen Vehicle Slowdown and Remote Ignition Block are only available on select 2009 and newer GM vehicles. ⁷Requires an active factory-installed theft-deterrent system, the Security or Guidance Plan and selected notification preference(s). Capability varies by model. Message and data rates may apply. Your vehicle's electrical systems and your smartphone (or other device) must be operative and sending/receiving data via wireless services and GPS satellite signals for the Theft Alarm Notification service to function properly. Vehicles must be locked electronically to arm the factory-installed theft-deterrent system. Theft Alarm Notifications are sent only to you. OnStar does not notify police of a Theft Alarm Notification. The Theft Alarm Notification service may alert you to a theft in progress. Always use caution and good judgement. Do not approach the vehicle unless you are certain the situation is safe. OnStar is not responsible for the acts of third parties. See OnStar User Terms and onstar.ca for system limitations. ⁸Requires ABS and Guidance Plan. Visit onstar.ca for coverage map. Services vary by model. ⁹Visit onstar.ca for coverage map, details and system limitations. Services vary by model and conditions. Unlock feature requires automatic door locks. Remote Start requires factory-installed and enabled remote-start system. ¹⁰OnStar Hands-Free Calling requires an existing OnStar service plan and available prepaid minutes. Not available in certain markets. Calls may be made to the U.S. and Canada only. Minutes good for the specified term or until service plan expires, whichever comes first. Visit onstar.ca for coverage map, details and system limitations [including geographic and technical restrictions]. ¹¹PRICELINE is a service mark of priceline.com LLC. ¹²Availability and capabilities vary by model. Visit onstar.ca for details and system limitations. Message and data rates may apply. Requires an active OnStar service plan, email address on file and enrollment in Advanced Diagnostics. Diagnostic Alerts are designed to help provide the status of key systems based on information collected from the vehicle. Proactive Alerts are designed to help predict specific types of issues based on information collected from the vehicle. Other factors may affect vehicle performance. Not all issues will deliver alerts. In certain scenarios, a dealer service check may be required to confirm the accuracy of the Diagnostic and Proactive Alerts.

COLOUR AND TRIM

ACCENTS



Refined Silver Metallic



Smoked Mahogany Wood Tone

INTERIOR COLOURS AND SEATING SURFACES



Jet Black/Light Titanium Premium Cloth

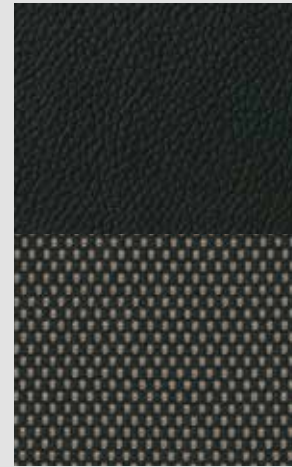

Jet Black/Jet Black Premium Cloth



Jet Black/Light Titanium Perforated Leather-Appointed

MODELS

SLE



SLT



DENALI



KEY ● STANDARD — NOT AVAILABLE

EXTERIOR COLOURS

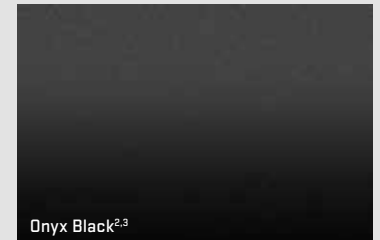
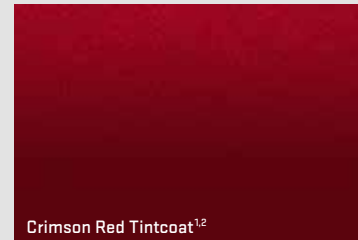
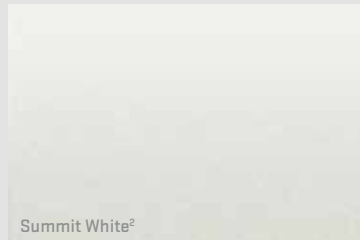

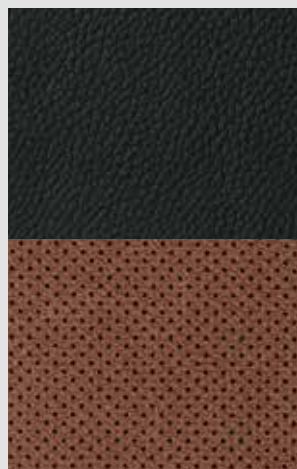

Jet Black/Saddle Perforated
Leather-Appointed



Jet Black/Jet Black Perforated
Leather-Appointed

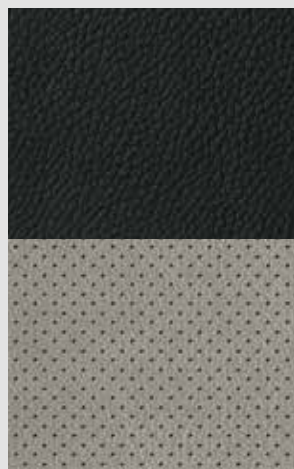

Jet Black/Light Titanium Perforated
Leather-Appointed



Jet Black/Jet Black Perforated
Leather-Appointed

-

•

-

-

•

-

-

-

•

-

-

•

WHEELS



18" MACHINED ALUMINUM
WITH PAINTED ACCENTS (REY)
Standard on SLE-1, SLE-2 and SLT



18" ALUMINUM WITH GLOSS-BLACK
ACCENTS (RRT)
Included and only available with
Nightfall Edition Package



18" SATIN-CHROME-CLAD
ALUMINUM (RV6)
Standard on Denali with I-4 engine



19" ULTRA-BRIGHT MACHINED
ALUMINUM WITH PAINTED
ACCENTS (RGG)
Standard on Denali with V6 engine



Quicksilver Metallic

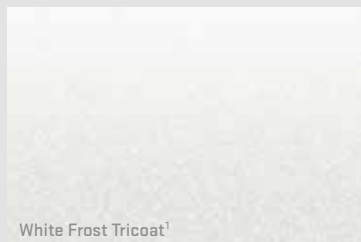

White Frost Tricoat¹



Dark Sapphire Blue Metallic^{1,3}

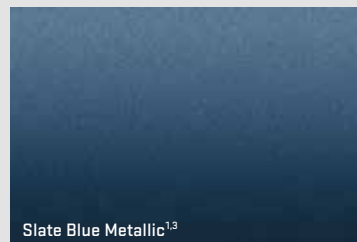

Slate Blue Metallic^{1,3}

TERRAIN SPECIFICATIONS

TRIM LEVELS

MECHANICAL

	SLE-1	SLE-2	SLT	DENALI
ALTERNATORS 120 amps	●	●	●	●
155 amps. Included and only available with 3.6L V6 Variable Valve Timing (VVT) direct-injection engine.	–	○	○	○
BATTERIES 525 cold-cranking amps with rundown protection. Included with 2.4L I-4 VVT direct-injection engine.	●	●	●	●
615 cold-cranking amps with rundown protection. Included and only available with 3.6L V6 VVT direct-injection engine.	–	○	○	○
BRAKES 4-wheel anti-lock, 4-wheel disc	●	●	●	●
DRIVETRAINS Front-Wheel Drive (FWD)	●	●	–	–
All-Wheel Drive (AWD)	○	○	●	●
ENGINES 2.4L I-4 VVT Direct Injection, 16-valve 4-cylinder; 182 hp, 172 lb.-ft. of torque	●	●	●	●
3.6L V6 VVT Direct Injection; 301 hp, 272 lb.-ft. of torque	–	○	○	○
ENGINE BLOCK HEATER	○	○	○	○
EXHAUST Single	●	●	●	●
Dual with premium tips. Included and only available with 3.6L V6 VVT direct-injection engine.	–	○	○	○
STABILITRAK Vehicle stability enhancement system. Includes Trailer Sway Control.	●	●	●	●
STEERING Power with variable electric assist	●	●	●	●
Power with hydraulic assist. Included and only available with 3.6L V6 VVT direct-injection engine.	–	○	○	○
SOFT RIDE SUSPENSIONS Front independent with strut-type coil springs	●	●	●	●
Rear independent trailering arm with 3 lateral locating links, coil springs	●	●	●	●
Enhanced ride and handling with dual-flow front dampers	–	–	–	●
TRACTION CONTROL	●	●	●	●
TRANSMISSION 6-speed automatic	●	●	●	●

SEATING

SEATS Premium cloth	●	●	–	–
Ultrasoft perforated leather-appointed	–	–	●	–
Ultrasoft perforated leather-appointed with embossed Denali logo on front seats	–	–	–	●
Front buckets	●	●	●	●
60/40 split rear bench, 3-passenger with Multi-Flex manual fore/aft adjustment and recline feature	●	●	●	●
Heated driver and front-passenger seats	–	●	●	●
Driver 2-way manual fore/aft adjuster, power lumbar and power seat height (up/down)	●	–	–	–
Driver 8-way power seat adjuster and power lumbar	–	●	●	●
Passenger 8-way power seat adjuster and power lumbar. On SLT, included and only available with Memory Settings Package.	–	–	○	●

INSTRUMENTATION AND CONTROLS

CRUISE CONTROL	●	●	●	●
INSTRUMENTATION Includes speedometer, single-trip odometer, fuel level, engine temperature, tachometer and Driver Information Centre with compass display	●	●	●	●
REAR VISION CAMERA Integrated into audio system screen. Includes dynamic grid lines.	●	●	●	●

TRIM LEVELS

	SLE-1	SLE-2	SLT	DENALI
STEERING WHEEL Comfort-grip vinyl with integrated audio and cruise controls	●	–	–	–
Leather-wrapped with mounted audio and cruise controls	–	●	●	–
Leather-wrapped with smoked mahogany wood tones and mounted audio and cruise controls	–	–	–	●
Tilt and telescopic steering column	●	●	●	●
TIRE PRESSURE MONITORING SYSTEM Does not monitor spare tire	●	●	●	●
UNIVERSAL HOME REMOTE Includes garage-door opener, programmable. On SLT, included and only available with power liftgate.	–	–	○	●

INTERIOR DETAILS

ASSIST HANDLES Front passenger and rear outboard	●	●	●	●
AUXILIARY POWER OUTLETS 4 12-volt with covers	●	●	●	●
CLIMATE CONTROL Single-zone manual air conditioning	●	–	–	–
Single-zone automatic air conditioning	–	●	●	●
CONSOLE Front centre with armrest and concealed storage	●	●	●	●
CUPHOLDERS 4 front, 4 rear, including 2 in centre armrest	●	●	●	●
DEFOGGER Rear-window electric	●	●	●	●
FLOOR MATS Carpeted front and rear	●	●	●	●
LIGHTING Theatre dimming, centre-mounted dome, cargo area and dual front map lights	●	●	●	●
Ambient lighting on integrated centre stack. On SLT and Denali, includes door pulls, cupholders and centre console area.	●	●	●	●
MIRRORS Interior rear-view, auto-dimming	●	●	●	●
POWER DOOR LOCKS Programmable with lockout protection	●	●	●	●
REMOTE KEYLESS ENTRY	●	●	●	●
REMOTE VEHICLE STARTER SYSTEM Includes extended-range Remote Keyless Entry	–	●	●	●
SILL PLATES Polished aluminum with front illumination	–	–	–	●
SUNROOF Power, tilt-sliding with express-open and wind deflector. On SLT, included with Sun and Destination Package.	–	○	○	●
VISORS Driver and front-passenger with illuminated vanity mirrors	●	●	●	●
WINDOWS Power with driver and front-passenger express-down	●	●	●	●

OPTION PACKAGES

CARGO MANAGEMENT PACKAGE Includes cargo cover, cargo convenience net and luggage crossbars	–	○	○	○
CHROME EDITION PACKAGE Includes chrome-accented grille, chrome door handles and exterior power-adjustable heated, manual-folding chrome mirrors	–	○	–	–
DRIVER ALERT PACKAGE 1 Includes Side Blind Zone Alert, Rear Cross Traffic Alert and Rear Park Assist. On SLT, includes power programmable liftgate and Universal Home Remote.	–	○	○	●
DRIVER ALERT PACKAGE 2 Includes Forward Collision Alert and Lane Departure Warning. On SLE-2, requires Driver Alert Package 1.	–	○	○	●
MEMORY SETTINGS PACKAGE Includes memory settings for driver seat and exterior rear-view mirrors. On SLT, includes power passenger seat.	–	–	○	●
NIGHTFALL EDITION PACKAGE Late availability on SLE-2 trim. Includes charcoal grille with gloss-black surround and accents, black front and rear fascia accents with gloss-black rear licence plate trim, body-colour door handles, charcoal luggage rails, exterior heated power-adjustable, gloss-black manual-folding mirrors and 18" aluminum wheels with gloss-black accents.	–	○	○	–
SUN AND DESTINATION PACKAGE Includes sunroof, Colour Touch Navigation ¹ with IntelliLink ² power programmable liftgate, Universal Home Remote and Driver Alert Package 1	–	–	○	–

TRIM LEVELS	SLE-1	SLE-2	SLT	DENALI		SLE-1	SLE-2	SLT	DENALI
ENTERTAINMENT/COMMUNICATION/NAVIGATION									
COLOUR TOUCH AUDIO SYSTEM AM/FM stereo, 178 mm diagonal touch-screen Colour Interface Display, USB port, ³ MP3 playback capability, speed-compensated volume and auxiliary input jack	●	●	●	–		●	●	●	●
INTELLILINK ² Includes Bluetooth ^{®3} streaming audio for music and select phones; hands-free smartphone integration with Stitcher SmartRadio ^{®4} integrated radio app and voice-activated technology for radio and phone	–	●	●	●		–	●	●	●
COLOUR TOUCH NAVIGATION SYSTEM¹ WITH INTELLILINK² AM/FM stereo, 178 mm diagonal touch-screen Colour Interface Display, GPS navigation system, USB port, ³ MP3 playback capability, Radio Data System (RDS) ⁵ speed-compensated volume, auxiliary input jack and outside temperature display	–	○	○	●		–	–	○	●
SOUND 6-speaker system	●	–	–	–		–	●	○	–
Pioneer [®] premium 8-speaker system with subwoofer and amplifier	–	●	●	●		–	–	●	●
SIRIUSXM SATELLITE RADIO ⁶ Includes 3 trial months of service	●	●	●	●		–	○	○	○
NAVTRAFFIC ⁶ Includes 3 trial months of service and only available with Colour Touch Navigation ¹	–	○	○	●		●	●	–	–
SIRIUSXM TRAVEL LINK ⁶ Includes 3 trial months of service and only included with Colour Touch Audio System with IntelliLink ²	–	●	●	●		–	○	○	–
BLUETOOTH ³ For phone, personal cellphone connectivity to vehicle audio system and Human Machine Interface	●	●	●	●		–	–	–	●
ONSTAR ⁷ 5-year Basic Plan and 6-month Guidance Plan	●	●	●	●		●	●	●	●
4G LTE. ⁸ Includes Wi-Fi [®] hotspot capability (with 3-month/3 GB trial, whichever comes first).	●	●	●	●		●	●	●	●
EXTERIOR STYLING AND FUNCTIONALITY									
DOOR HANDLES Body-colour. On SLT, included and only available with Nightfall Edition Package.	●	●	○	–		●	●	●	●
Bright chrome (satin chrome on Denali). On SLE-2, included and only available with Chrome Edition Package.	–	○	●	●		●	●	●	●
FRONT AND REAR BUMPERS Body-colour	●	●	●	–		●	●	●	●
Body-colour with silver painted rear skid plate	–	–	–	●		●	●	●	●
GLASS Solar-Ray deep-tinted. All windows except light-tinted glass on windshield and driver and front-passenger side.	●	●	●	●		–	○	○	●
GRILLE Charcoal with chrome surround	●	●	–	–		–	○	○	●
Charcoal with gloss-black surround and accents. Included and only available with Nightfall Edition Package.	–	○	○	–		–	○	○	●
Charcoal with chrome surround and accents	–	–	●	–		–	–	–	●
Denali-specific with chrome surround	–	–	–	●		●	●	●	●
SAFETY AND SECURITY									
AIRBAGS ⁹ Frontal dual-stage with Passenger Sensing System and side-impact, driver and front passenger plus head curtain side-impact with rollover protection, front and rear outboard seating positions	●	●	●	●		●	●	●	●
CHILD SAFETY LOCKS	●	●	●	●		●	●	●	●
LATCH (Lower Anchors and Top tethers for CHildren) system	●	●	●	●		●	●	●	●
SAFETY BELTS 3-point, all seating positions	●	●	●	●		●	●	●	●
DRIVER ALERT PACKAGE 1 Includes Side Blind Zone Alert, Rear Cross Traffic Alert and Rear Park Assist. On SLT, includes power programmable liftgate and Universal Home Remote.	–	○	○	●		–	○	○	●
DRIVER ALERT PACKAGE 2 Includes Forward Collision Alert and Lane Departure Warning. On SLE-2, requires Driver Alert Package 1.	–	○	○	●		–	○	○	●
VEHICLE THEFT-DETERRENT SYSTEM Includes engine immobilizer	●	●	●	●		●	●	●	●

¹At time of printing, detailed map coverage is available for most major urban areas of the United States and for certain metropolitan areas of Canada (Vancouver, Calgary, Edmonton, Winnipeg, Windsor, London, Toronto, Ottawa, Montreal, Quebec City and Halifax). Coverage is significantly limited outside these areas. ²Full functionality requires compatible Bluetooth and smartphone, and USB connectivity for some devices. Visit intellilink.gmc.com for more details. ³Not compatible with all devices. ⁴Data plan rates apply. ⁵RDS functions only where stations broadcast RDS information. ⁶Available in 10 Canadian provinces and the 48 contiguous United States. Subscription sold separately after trial period. If you decide to continue your service at the end of your trial subscription, the plan you choose will automatically renew and bill at then-current rates until you call 1-877-209-0079 to cancel. Other fees and taxes will apply. All fees and programming subject to change. See SiriusXM "Terms & Conditions" and complete details at siriusxm.ca. ⁷The OnStar Basic Plan is available for 5 years from the date of delivery of the eligible new 2015 model year and newer vehicles and is transferable to subsequent owners for the remaining term. The Basic Plan includes access to: (1) monthly Diagnostics Report emails (capabilities vary by model); (2) Dealer Maintenance Notification; and (3) limited myGMC mobile app services, which include remote start (requires factory-installed and enabled remote-start system), remote lock/unlock doors (requires automatic locks) and remote horn and lights activation. The myGMC mobile app is available on select Apple, Android, BlackBerry and Windows devices. Visit onstar.ca for vehicle availability, coverage map, details and system limitations. The OnStar Basic Plan does not include any Emergency Services, Automatic Crash Response, Stolen Vehicle Assistance, live Advisor service or Hands-Free Calling. These and other services are available under a paid plan. If you sell your vehicle or wish to cancel use of Basic Plan services, you must contact OnStar at 1-888-4-ONSTAR (1-888-466-7827). ⁸Visit onstar.ca for coverage maps, details and system limitations. Available 4G LTE Wi-Fi requires compatible mobile device, active OnStar service and data plan. Services vary by model, conditions and geographical and technical restrictions. OnStar with 4G LTE connectivity is available on select vehicle models and in select markets. OnStar acts as a link to existing emergency service providers. Not all vehicles may transmit all crash data. After the trial period (if applicable), an active OnStar service plan is required. ⁹Always use safety belts and the correct restraint for your child's age and size. Even in vehicles equipped with the Passenger Sensing System, children are safer when properly secured in a rear seat in the appropriate infant, child or booster seat. Never place a rear-facing infant restraint in the front seat of any vehicle equipped with a passenger airbag. See the Owner's Manual and child safety seat instructions for more safety information.

STANDARD TECHNICAL DATA

2.4L I-4 VVT ENGINE

Horsepower @ rpm	182 @ 6700
Torque @ rpm (lb.-ft.)	172 @ 4900
Fuel delivery	Spark-ignited direct fuel injection

3.6L V6 VVT ENGINE

Horsepower @ rpm	301 @ 6500
Torque @ rpm (lb.-ft.)	272 @ 4800
Fuel delivery	Spark-ignited direct fuel injection

TRANSMISSION

6-speed automatic

STANDARD FRONT-WHEEL DRIVE (FWD)**AVAILABLE ALL-WHEEL DRIVE (AWD)**

Active AWD

BRAKES

4-wheel disc with anti-lock braking system

STEERING

Variable electric rack-and-pinion system (hydraulic on V6)

BATTERY

Maintenance-free with rundown protection

STANDARD ALTERNATOR (I-4/V6)

120 amps/155 amps

FUEL TANK CAPACITY (I-4/V6)

71 litres (15.6 imp. gal.)/79 litres (17.4 imp. gal.) (approx.)

ESTIMATED FUEL-CONSUMPTION RATING¹ (L/100 km) (mpg)

2.4L I-4 VVT Direct Injection	FWD 11.0 (26) city, 7.5 (39) hwy AWD 11.5 (25) city, 8.3 (34) hwy
3.6L V6 VVT Direct Injection	FWD 14.1 (20) city, 9.7 (29) hwy AWD 15.0 (19) city, 10.4 (27) hwy

MAX TRAILERING WEIGHTS² (kg) (I-4/V6)

680/1588

EXTERIOR DIMENSIONS (mm)

Overall Height	1684 without roof rails
Overall Width	1849
Overall Length	4712
Wheelbase	2858

INTERIOR DIMENSIONS (mm)

Head Room	Front 1011/Rear 996
Leg Room	Front 1046/Rear (max) 1013
Shoulder Room	Front 1415/Rear 1405
Hip Room	Front 1400/Rear 1303

MAXIMUM CARGO-AREA CAPACITIES (litres)³

Behind first row	1809
Behind second row	895

¹Fuel-consumption estimates based on GM preliminary testing in accordance with Government of Canada approved test methods. Refer to vehicles.nrcan.gc.ca for details. Your actual fuel consumption may vary. ²Before you buy a vehicle or use it for trailering, carefully review the trailering section of the Owner's Manual. The weight of passengers, cargo and options or accessories may reduce the amount you can tow. ³Cargo and load capacity limited by weight and distribution.

IMPORTANT WORDS

PEACE OF MIND, STANDARD WITH EVERY GMC MODEL

When you build them with quality, you can back them with confidence. That's why General Motors of Canada backs every GMC model with the best coverage in Canada. Program highlights include:

- 2-year/48,000 km Lube-Oil-Filter Maintenance¹
- 3-year/60,000 km New-Vehicle Limited Warranty²
- 5-year/160,000 km Powertrain Limited Warranty, with \$0 deductible on repairs and the warranty is fully transferable at no charge²
- 5-year/160,000 km Courtesy Transportation²
- 5-year/160,000 km 24/7 Roadside Assistance²
- 6-year/160,000 km rust-through perforation coverage²
- 8-year/130,000 km coverage on catalytic converters and Powertrain Control Modules (PCMs)²

OTHER OWNERSHIP PRIVILEGES AND PROGRAMS:³

- **GM Protection Plan (GMPP)**—The only extended service plan backed by the resources and commitment of General Motors, GMPP may be purchased at the time of sale or subsequently during the New-Vehicle Limited Warranty period.
- **Certified Service**—With GM-certified technicians and GM-approved parts, nobody knows your GM vehicle better.
- **GMC Owner Centre**—As an owner, take advantage of the GMC Owner Centre. This online owner's destination gives you access to coupons, contests, current offers and the latest driving and maintenance tips. Find out more at gmcowner.ca.

TO HELP YOU PURCHASE OR LEASE A NEW VEHICLE:

- **Purchase Financing and Leasing**—On-the-spot financing, see dealer for full details.⁴
- **GM Student Bonus Program**—Students or recent graduates of high school, college or university³ may be eligible to receive a Student Bonus vehicle redemption allowance of \$500 or \$750⁵ (tax inclusive) (purchased vehicle dependant) to use toward the purchase, lease or finance of one eligible new GMC vehicle.
- **GM Card**—Cardholders may redeem Earnings toward the total purchase price or lease down payment of an eligible new GMC truck, SUV or crossover. Restrictions and limitations apply.⁵ For full program details, visit gmc card.ca.

INFORMATION RESOURCES:

You can find more information about these programs from your GMC dealer, or at these information centres:

- The GM website at gm.ca
- The GM Customer Care Centre at **1-800-GM-DRIVE (1-800-463-7483 or 1-800-263-3830** for TDD users)

A WORD ABOUT THIS BROCHURE

Some of the equipment shown or described throughout this brochure may be available at extra cost. We have tried to make this brochure comprehensive and factual. We reserve the right, however, to make changes at any time, without notice, in prices, colours, materials, equipment, specifications, models and availability. Specifications, dimensions, measurements, ratings and other numbers in this brochure and other printed materials provided at the dealership or affixed to vehicles are approximates based upon design and engineering drawings and prototypes and laboratory tests. Your vehicle may differ due to variations in manufacture and equipment. Since some information may have been adapted since the time of printing, please check with your GMC dealer for complete details. General Motors of Canada Company reserves the right to lengthen or shorten the model year for any product, for any reason, or to start and end model years at different times.

A WORD ABOUT ASSEMBLY

GMC vehicles are equipped with engines and components produced and assembled by different operating units of General Motors, its subsidiaries and suppliers to GM worldwide. We sometimes find it necessary to produce GMC vehicles with different or differently sourced components than originally scheduled. Since some options may be unavailable when your vehicle is assembled, we suggest that you verify that your vehicle includes the equipment you ordered or, if there are changes, that they are acceptable to you.

TRADEMARKS

©2016 General Motors of Canada Company. All rights reserved. The marks appearing in this brochure, including but not limited to: General Motors, GM, GMC, Terrain, Denali and their respective logos, emblems, slogans and vehicle model names and body designs; and other marks such as Solar-Ray and StabiliTrak are trademarks of General Motors and/or General Motors of Canada Company, its subsidiaries, affiliates or licensors. OnStar and the OnStar emblem are registered trademarks of OnStar, LLC. The SiriusXM name and related logos are trademarks of SiriusXM Canada, Canadian Satellite Radio, Inc. Bluetooth is a registered trademark of Bluetooth SIG, Inc. Pioneer is a registered trademark of Pioneer Corporation. Apple is a registered trademark of Apple, Inc. Android is a trademark of Google, Inc. BlackBerry is a registered trademark of BlackBerry Limited. Windows is a registered trademark of Microsoft Corporation.

¹Limit of four complimentary Lube-Oil-Filter services in total. Fluid top-offs, inspections, tire rotations, wheel alignments and balancing, etc., are not covered. Conditions and limitations apply. See your dealer for details. ²Whichever comes first. Conditions and limitations apply; see dealer for details. ³Conditions and limitations apply. ⁴Subject to eligibility. ⁵Program subject to change.

GMC

WE ARE PROFESSIONAL GRADE

