

OPEL VIVARO





DESIGNED TO GET WORK DONE.

The Opel Vivaro has everything it takes to get the job done. The presence of a front-line flagship, a comfortable cabin and spacious load area. Reliability, fuel economy and FlexCare after-sales support mean your Vivaro's always ready to put in a shift.

// Exceptional **LOW COST** of Ownership

// Stylish **DESIGN AND PRESENCE** for a strong company image

// Variants and **VERSATILITY** for different business needs

// **FLEXCARE** keeps your van on the road longer

// Comprehensive financing delivers **EXCELLENT VALUE** for money

The contents of this catalogue were accurate at the time of going to print (10/2016). We reserve the right to alter specifications and equipment at any time. Please consult your Opel dealer for the very latest information.

CONTENTS

OPEL VIVARO	04	THE VIVARO
		MODELS
	16	PANEL VAN
	22	CREW VAN
	26	COMBI
	32	PLATFORM CAB
		INNOVATIONS
	34	MOBILE OFFICE
	36	SAFETY AND INFOTAINMENT
	38	CARGO AND COMFORT
	40	RACKING SYSTEMS
	42	ACCESSORIES
	44	VARIANTS
	46	ENGINES AND TRANSMISSIONS
	48	ECOFLEX TECHNOLOGIES
	50	TRIMS AND SURFACES
	52	PAINTS AND WHEELS
	56	OPEL SERVICE
	58	HIGHLIGHTS

YOU HAVE THE TASK. WE HAVE THE TOOL.





FIRST IMPRESSION: FIRST CLASS.

The Vivaro is the model professional. Confident styling and quality workmanship prove your business means business.

- // OUTSTANDING DESIGN makes an impressive business card
- // Four CUSTOMISABLE BODY TYPES cater to varied needs
- // PANEL VAN for payloads large and small
- // CREW VAN for SIX PEOPLE plus a sizeable payload
- // Combi with flexible seating for up to NINE PEOPLE
- // Platform cab as base for UNIVERSAL CONVERSIONS





D F GG 9028



BUILT TO ADAPT.

The best tradesmen deserve the best tools. So Opel made the Vivaro a comfortable place to get things done. A wide range of options lets you customise the cabin and transform your van.

// Versatility for MAXIMUM PRODUCTIVITY

// INTERIOR ADAPTS to people and cargo

// OFFICE BENCH SEAT with clipboard, desk and storage

// Driver's seat with ARMREST and lumbar support

// ADJUSTABLE STEERING WHEEL, for rake and reach

For more information, turn to pages 30 and 34.



PAYLOAD THAT PAYS OFF.

If you've bulk goods to move, the Vivaro's your van. The Panel Van comes with two wheelbases and two roof heights and is sturdy, reliable, variable – and spacious.

// HEAVY PAYLOAD up to 1.2 tonnes

// LONG CARGOES up to 2,537 mm or 2,937 mm

// LOAD WIDTH between wheel arches 1,268 mm

// 5.2 m³ to 8.6 m³ MAXIMUM LOAD VOLUME

// Even short version takes THREE EURO-PALLETS

// BULKHEAD HATCH extends load length to 4.15 m

For more information, turn to pages 16 and 44.









SAVING BY DOING.

Class-leading efficiency boosts your profits and low emissions give the environment a lift. Low Total Cost of Ownership means your Vivaro can increase your income.

- // Among BEST-IN-CLASS consumption and emissions
- // Low-displacement turbos for INCREASED EFFICIENCY
- // Advanced BITURBO ENGINES available
- // ECO MODE for optimal fuel economy

For more information, turn to pages 46–48.

SAFETY AT WORK.

Peace-of-mind is a must in the workplace, so safety comes first in the Vivaro. Powerful technologies protect your people, your property and your company.

- // ESP® CONTROL in difficult conditions
- // TRACTION CONTROL enhances grip
- // ADAPTIVE LOAD CONTROL considers payload
- // HILL START ASSIST for safer starts
- // TRAILER SWAY ASSIST¹ for trailer stability
- // BLIND ANGLE MIRROR for improved visibility
- // POWERFUL HEADLAMPS
- // LED Daytime Running Lights

For more information, turn to page 36.

¹In combination with optional trailer hitch.





D F GG 90



PANEL VAN.

Versatility, power, variants and options. The Vivaro Panel Van with standard roof height has them all.

PANEL VAN STANDARDS INCLUDE

- // Two wheelbases
- // 2,537 mm or 2,937 mm load lengths
- // Up to 1,205 kg payload
- // Easy-access, 1 m wide passenger-side sliding door
- // Twin rear doors open up to 250°
- // Side and rear doors take a euro-pallet with ease
- // Floor-mounted, load-securing eyes
- // Powerful, efficient 1.6 litre CDTI Euro 6 diesel engines

Images may show optional equipment.



1. LOAD-SPACE OPTIONS. The optional FlexCargo® load-through bulkhead option extends load length up to 4.15 m.

2. OPTIONAL 250° OPENING REAR DOORS AND RESTRAINING LATTICE. For safe, easy loading the doors fold back and fasten to the side of the van. Two restraining lattices protect driver and co-driver from heavy load.



PANEL VAN HIGH ROOF.

Higher and mightier. The Vivaro Panel Van with space to make easy work of bulky loads.

PANEL VAN HIGH ROOF STANDARDS INCLUDE

- // Versatile 1,897 mm load height
- // Two wheelbases
- // Load volume 7.2 m³ with 2,537 mm load length
- // 8.6 m³ load volume with 2,937 mm load length
- // Full-height doors open up to 180°
- // Side sliding door takes a euro-pallet
- // Floor-mounted, load-securing eyes
- // Up to 1,151 kg payload

Images may show optional equipment.



FULL STANDING HEIGHT. Extra height, easy access and plenty of space means the Vivaro high-roof versions not only carry larger loads, they also make the perfect mobile workshop.

PANEL VAN.

The Panel Van is a power player with excellent spec.

PANEL VAN CHOICES

- // Two wheelbases
- // Two roof heights
- // Ample load space up to 8.6 m³
- // Payload up to 1.2 tonnes
- // Secure steel or glazed bulkhead
- // Glazed or unglazed rear and side doors
- // Rear swing doors or a tailgate
- // Heated rear window with wipers

For more information, turn to page 44.



Images may show optional equipment.

1. FOLD-DOWN CONVERTIBLE OFFICE BENCH SEAT. The centre seat has a removable clipboard that can stand vertical while the seat back converts into a desk for a laptop. Both seat cushions also flip up to reveal 42 litres of built-in storage.

2. LEATHER STEERING WHEEL WITH CRUISE CONTROL. For safer, more comfortable driving all day.

3. LARGE GLOVE BOX. With plenty of space for A4 documents.

4. FRONT FOG LAMPS. See and be seen.

PANEL VAN.

THE FOLLOWING FEATURES COME STANDARD:

- // 16" steel wheels with centre cap
- // Daytime Running Lights (halogen)
- // Steel bulkhead
- // Remote central door locking
- // Electric windows
- // Front passenger bench
- // 12-V dashboard socket
- // Driver airbag
- // Tricess Blue trim fabric
- // Dashboard in Denim Blue
- // R16 Bluetooth® USB radio
- // Electrically adjustable, heated side mirrors
- // Steel bulkhead
- // 6-way adjustable driver's seat with armrest, lumbar support
- // 12-V socket in load space
- // Exterior temperature display
- // Large glove box with lid

PANEL VAN WITH APPEARANCE PACK.

ALL THE FEATURES OF THE PANEL VAN, PLUS:

- // 16" steel wheels with full cover
- // Front and rear outer bumpers in body colour
- // LED Daytime Running Lights
- // Leather-wrapped steering wheel
- // Front fog lamps

4.





CREW VAN.

The Crew Van gives you space and fast access.
For your teams and their tools.

CREW VAN STANDARDS INCLUDE

- // Comfortable seating for up to six adults
 - // Welcoming three-seater second-row bench
 - // Generous rake on second-row seats
 - // Smart trim for an appealing interior
 - // Reinforced bulkhead
 - // Up to 4.0 m³ adaptable load space
- For more information, turn the page.

Images may show optional equipment.



SLIDING SIDE DOOR. The extra-wide opening puts rear-seat passengers at their ease from the start. It provides uncluttered access to the three comfortable seats that make up the bench in the back.

CREW VAN TRIM LEVELS.

The Vivaro Crew Van seats up to six in comfort. Heavy gear can be safely stowed behind the bulkhead.

CREW VAN CHOICES

- // Two wheelbases: 3,098 m or 3,498 m
- // Three-seater second-row bench with armrests
- // Full side cladding and storage
- // Glazed or unglazed tailgate

Images may show optional equipment.

¹Available on Crew Van Mid.



1.–2. LOADS OF LOAD SPACE. There's instant access to underseat storage in the passenger section¹, plus up to 4.0 m³ behind the bulkhead.



CREW VAN BASE.

THE FOLLOWING FEATURES COME STANDARD:

- // Comfortable three-seater second-row bench
- // Roof liner with bright and glare-free dome-style ceiling lamp
- // Half-height side wall trim with storage
- // Side windows in second row

CREW VAN MID.

ALL THE FEATURES OF THE BASE, PLUS:

- // Three-seater second-row bench and storage area under seat two and three
- // Maximum child safety thanks to ISOFIX mounting points
- // Practical bench-mounted pocket
- // Bench-mounted 12-V socket for portable devices
- // Full side wall trim with 1.5-l bottle holder and cupholder

CREW VAN UPLEVEL.

ALL THE FEATURES OF THE MID, PLUS:

- // Individually adjustable second-row seats with armrests
- // Individual LED lights and two speakers roof liner, second row
- // Full side wall trim with sunshades in second-row window frame cladding
- // Black seat trim
- // Illuminated entry step, second row

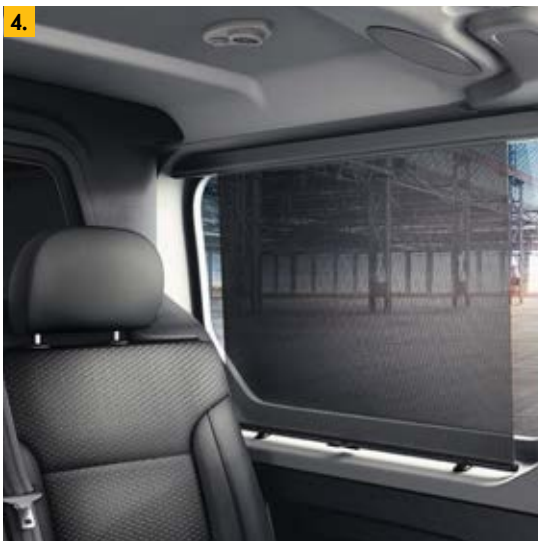
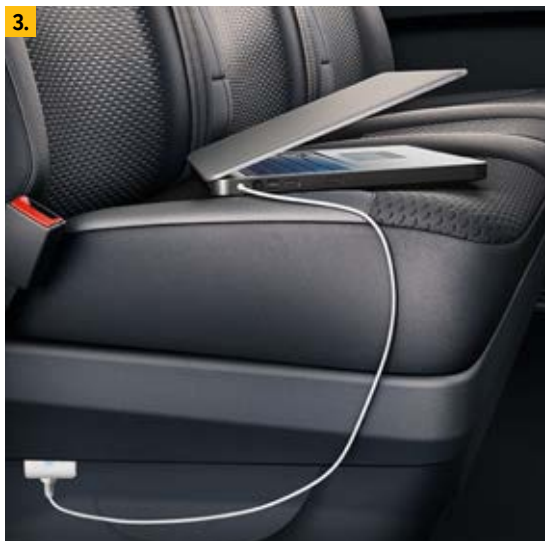

2.-3. MULTIFUNCTIONAL SECOND-ROW BENCH. Mid and Uplevel owners can offer passengers a 12-V power socket and side pocket. Additionally illuminated step lamp available for Uplevel.

4. SIDE WINDOW WITH SUNBLIND. Integrated within the window frame for extra strength.

5. LED lights and additional speakers for rear passengers.





COMBI.

The versatile Vivaro for anyone with up to nine people to carry. VIP hotel shuttle meets sports team transport.

COMBI STANDARDS INCLUDE

- // High levels of comfort and workmanship
- // Comfortable seating for up to nine people
- // Front passenger seat bench
- // Third-row bench seat folds and tumbles for storage
- // Two ISOFIX points for maximum child safety
- // Start/Stop System
- // Tyre Pressure Monitoring System
- // Hard-wearing rubber floor
- // Rear swing doors

For more information, turn the page.

Images may show optional equipment.



TILTABLE 60/40 SPLIT SECOND-ROW BENCH. Give your back seat passengers a clear and comfortable path between their seats and the side door.



LATTICE BULKHEAD. Tough, lightweight mesh, protects and restrains without affecting rearward vision.

COMBI TRIM LEVELS.

You couldn't ask for finer seating in a versatile working van.

COMBI VAN CHOICES

- // Two wheelbases cater different business needs
- // Complete exterior in body colour enhances design
- // Sliding rear windows
- // Single co-driver seat
- // Rear seat armrests
- // Air conditioning¹
- // Additional rear air conditioning¹
- // Additional rear heating
- // Tailgate with wash/wipe window

Images may show optional equipment.

¹The air conditioning in vehicles with N1 type approval relies upon fluorinated greenhouse gases (R 134a) for its functioning. The front system contains a quantity of overall 580 g of R 134a, which corresponds to a CO₂ equivalent of 0.83 tons. The front and rear system contains a quantity of overall 890 g of R 134a, which corresponds to a CO₂ equivalent of 1.27 tons. The global warming potential amounts to 1,430. Information acc. to R (EU) No. 517/2014. ²Standard with Cosmo Pack and Elegance Pack.

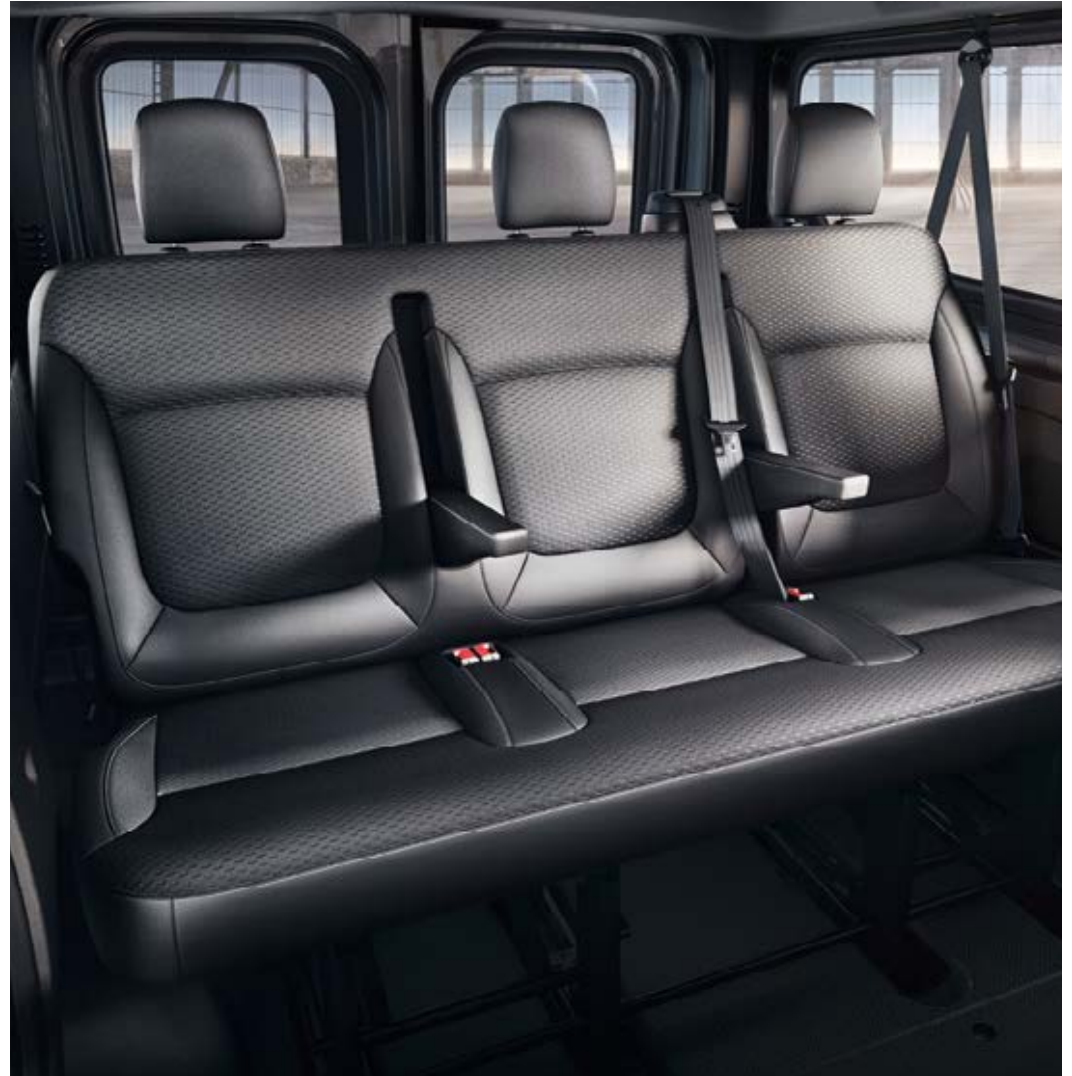

SECOND- AND THIRD-ROW BENCHES WITH ARMRESTS². Easy to remove for more load space.

COMBI.

THE FOLLOWING FEATURES COME STANDARD:

- // 16" steel wheels with smart centre cap
- // Daytime Running Lights (halogen)
- // Stylish Tricess Blue trim fabric
- // Matching dashboard in Denim Blue
- // R16 Bluetooth® USB radio
- // Electric windows and heated side mirrors
- // Front bench seats two passengers in comfort
- // Second- and third-row benches seat up to six
- // Remote central door locking
- // Driver and front passenger airbags
- // Rear swing doors



REAR HEATING SYSTEM. A heat exchanger and fan keep rear seat passengers warm in winter. An optional additional boiler² heats the vehicle even quicker.

COMBI WITH APPEARANCE PACK.

ALL THE FEATURES OF THE COMBI, PLUS:

- // 16" steel wheels protected by full cover
- // Cutting-edge Daytime Running Lights (LED)
- // Front fog lamps enhance safety and style
- // Leather steering wheel with cruise control
- // Front and rear outer bumpers in body colour



CONTROLS IN THE BACK. Additional heating and air-conditioning¹ controls give your Combi passengers the VIP treatment.

COMBI WITH ELEGANCE PACK.

ALL THE FEATURES OF THE COMBI WITH APPEARANCE PACK, PLUS:

- // CD18 Bluetooth® USB radio
- // Automatic windscreen wipers and lights
- // Air conditioning front and rear
- // Windows open in side door and in panel opposite
- // Rear tailgate replaces swing doors
- // Luggage cover
- // 17" alloy wheels
- // Elegant Connect Black trim fabric
- // Dashboard in sleek Carbon Black



LED DAYTIME RUNNING LIGHTS². LED lights get you noticed and look smarter, by day or by night.

GROWTH POTENTIAL.

The Combi is the most versatile Vivaro of all. The Crew Van is by definition a multi-talented multitasker.

- // Vary the seat/load space split in the Combi for up to nine people
- // Remove second- and/or third-row benches without any tools
- // Fold down third-row backrests for more versatility



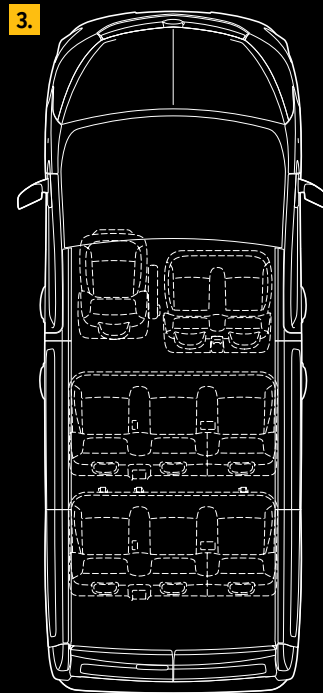
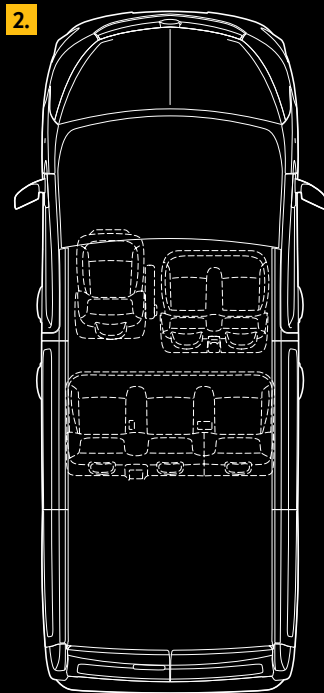
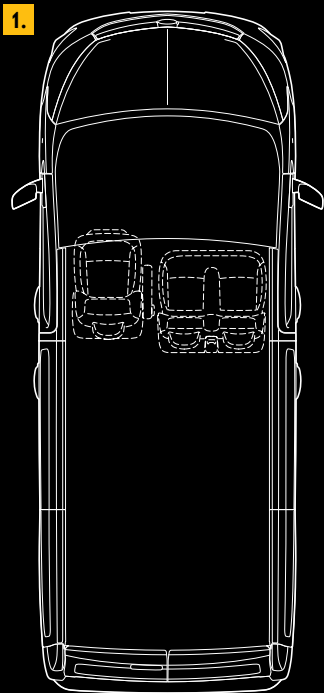

1. **THREE-SEATER COMBI.** Three up front, 5.2 m³ or 6.0 m³ of load space (depending on wheelbase).

2. **SIX-SEATER COMBI.** 3.2 m³ or 4.0 m³ load space behind the removable second-row bench (depending on wheelbase).

3. **NINE-SEATER COMBI.** Three rows of three, 1.8 m³ load space with long wheelbase. For more space, fold down the rear row or remove both benches.

4. **SIX-SEATER CREW VAN.** A full bulkhead separates passengers from a load compartment with space for a euro-pallet.

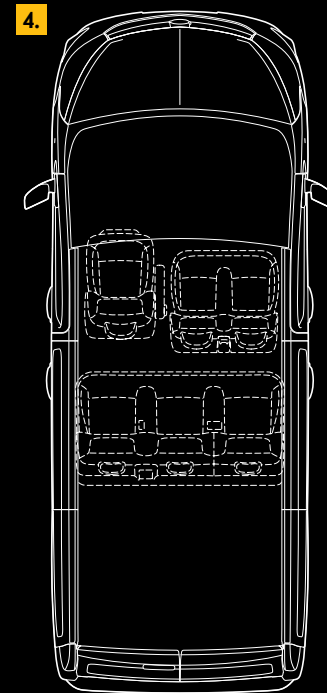





PLATFORM CAB.

Ultimate conversion potential, outstanding style and impressive flexibility. The Vivaro Platform Cab transforms perfectly, whatever your needs.

SPECIFICS

- // Max. gross vehicle weight of 2,990 kg
- // Versatile long wheelbase
- // Comprehensive comfort and safety equipment
- // Optimised for specialist bodywork
- // Optional engine-driven power take-off

Images may show optional equipment.

YOUR OUT-OF-OFFICE OFFICE.

The Vivaro is an ergonomic, well-organised office. There's a place for everything, and everything has its place.

YOUR OPEL MOBILE OFFICE INCLUDES

- // Maximum driver convenience and comfort
- // Steering-wheel mounted radio controls
- // Category-first office bench seat
- // Bluetooth® for hands-free phone and audio streaming
- // Large glove box for A4 documents
- // Easy-access dashtop shelf
- // Three cupholders
- // Optional dash-mounted smartphone holder¹
- // Optional dash-mounted tablet holder²

Images may show optional equipment.

¹Available as an option for all Opel supplied infotainment devices.

²Only with R16 Bluetooth® USB radio.





1. USB PORT. Hook up via USB for messages and more.

2. TABLET HOLDER². Allows tablets between 4.8 inches and 10.6 inches to be mounted in perfect sight and reach.

3. BUILT-IN, REMOVABLE CLIPBOARD. Part of the office bench seat. It's practical, flexible and removable.

SMARTER SYSTEMS. SAFER SURROUNDINGS.

The Vivaro is one of the most secure, best-connected vans on the market.

STANDARD SAFETY TECHNOLOGIES

- // ESP® with Electronic Brake-force Distribution and ABS
- // Hill Start Assist and Traction Control
- // Emergency Brake Assist
- // Adaptive Load Control
- // Active Rollover Protection
- // Trailer Sway Assist in combination with optional trailer hitch

STATE-OF-THE-ART INFOTAINMENT OPTIONS

All Opel audio and navigation systems include:

- // Bluetooth® and USB for smartphones and MP3 players
- // Steering wheel-mounted remote controls

REACH YOUR DESTINATION MORE RELAXED AND SAFELY WITH THE TOMTOM LIVE SERVICES¹

- // Get the fastest route with real-time traffic information
- // Check the weather ahead
- // Search and go to places around you

¹Only with Navi 80 IntelliLink, availability of the above features might differ in your country.





1.



2.



4.



3.



5.

1. NAVI 50 INTELLILINK. Excellent-value optional navigation system with a 7-inch (17.8-cm) touch screen and map coverage for Western or Eastern Europe with TMC (Traffic Message Channel). When connected to an Apple smartphone, Navi 50 supports Siri voice control and displays information about the music you are playing. The Navi is also screen for the optional Rear View Camera. Digital radio optional.

2. R16 BLUETOOTH® USB RADIO. With MP3/WMA playback from USB, Bluetooth® audio streaming and hands-free function 3.5-mm aux-in stereo jack plus optional digital radio.

3. CD18 BLUETOOTH® USB RADIO. The same specifications as the R16-Bluetooth® USB radio, but adds a CD player and is in double-DIN format.

4. NAVI 80 INTELLILINK. The intuitive, top-of-the-range system with 3-D viewing, advanced Voice Control, USB video player/photo reader and TomTom LIVE services* till 2020 without charge for real-time traffic information. The 7-inch display is also screen for the optional Rear View Camera.

5. CONCAVE BLIND ANGLE MIRROR in co-driver sunblind allows better orientation in tight spaces.



FLEXCARGO® FLEXIBILITY. A practical hatch in the FlexCargo® bulkhead lets you securely store cargo up to fully 4.15 metres long. Open the hatch and push it through under the passenger seat and up level with the glove box.



GRAB HANDLES on A, B and C pillars ease entry and exit.

CARGO AND COMFORT.

Factory-fitted options customise your Vivaro for specialist tasks.

// Choose from a broad selection of options

// Adapt your van to your specific business needs



1. SLIDING DOOR, DRIVER SIDE. Ideal for confined locations and separate workspace compartments. Grab handles ease access and exit.

2. FLOORING & SIDE PROTECTION. Anti-slip, resin-coated 9-mm plywood flooring offers grip and protection for cargo and staff. Humidity-resistant, easy-clean, plastic-coated 4-mm plywood side panels safeguard both your load and your van.

3. SIDE AND ROOF CLADDING. The Lightweight 4.7 mm plastic honeycomb panels and wheel house covers protect roof, sides and wheel arches. Grab handle on D pillar eases entry and exit.



Powered by
Sortimo®



1. SORTIMO SIMPLECO®

Flexible Simpleco® shelves are ideal for storing anything from documents to tools in a tidy and organised way.

SIMPLECO® STORAGE AT A GLANCE

- // Light construction
- // Shelf trays
- // Divider sets with anti-rattle mats
- // Lashing points with ProSafe hooks
- // Box floor
- // Sortimo S-BOXXes

MINIMAL PAYLOAD REDUCTION

- // Simpleco® reduces max. payload by just 68 kg

2. SORTIMO GLOBELYST®

Globelyst® turns your Vivaro into a mobile workshop packed with storage solutions that ensure you get the job done right on the spot.

OVER AND ABOVE SIMPLECO®, GLOBELYST® OFFERS LOTS OF ADDITIONAL FEATURES

- // Flexible Sortimo BOXXes of all shapes and sizes
- // Custom-made arrangeable shelves, draws and compartments
- // Handy storage pockets
- // Ratchet straps for extra security
- // Protective wall and floor cladding

MINIMAL PAYLOAD REDUCTION

- // Globelyst® reduces max. payload by just 141 kg

Sortimo Simpleco® and Globelyst® are supplementary, reversible enhancements applied and supported by Sortimo International GmbH. Adam Opel AG does not give any warranty for any of the package parts and is not liable for their quality. Specific spare parts can be ordered from sortimo.com. The racking system reduces the maximum payload of the base vehicle.

PRACTICALITY OFF THE SHELF.

A clean workspace is an essential foundation for a job well done. Give your Vivaro a flying start by ordering factory-fitted workspace solutions from Sortimo and bott.

TURN YOUR VIVARO INTO A WORKSHOP ON WHEELS

- // Flexible storage arrangement
- // Never lose anything ever again with clever storage solutions
- // Safe storage for maximum peace of mind

3.



3. BOTT CRAFTSMAN

With efficient compartments that can be configured to your individual needs, the bott Craftsman offers secure storage and quick access to tools and materials.

- // Light yet durable aluminium construction
- // Ample storage space
- // Configurable to individual needs
- // Protective side wall and floor cladding
- // Flexible storage solutions for every job

MINIMAL PAYLOAD REDUCTION

- // bott L1 reduces max. payload by just 81.6 kg
- // bott L2 reduces max. payload by just 86.2 kg

Powered by

bott

bott Craftsman is a supplementary, reversible enhancement applied and supported by Bott GmbH & Co. KG. Adam Opel AG does not give any warranty for any of the package parts and is not liable for their quality. Specific spare parts can be ordered from bott. The racking system reduces the maximum payload of the base vehicle.

ACCESSORIES.

When business parameters change, your van adapts with the times.

- // A host of accessories available post-purchase
- // Opel accessories are tailor-made for the Vivaro
- // Fit and remove as need be



Search our shelves. Go to www.opel-accessories.com for more options and accessories.



1. **ROOF CARRIER LADDER.** A must for safely loading and unloading the roof. This robust tubular steel ladder is available for the tailgate or swing doors.

2. **INTERIOR ROOF RACK.** Using the space beneath the roof frees up space on the load floor. The rack loads up to 12 kg and comes with a load stop.

3. **TOWING HITCHES.** From the detachable tow ball to the flange tow bar and the heavy-duty pin and ball-type.

4. **BASE CARRIER.** The sure-fire way to fasten long or awkward loads to the roof. The base carrier works best with a roof rack, ladder clamp, loading bars and load stop.

5. **WOODEN PROTECTION.** Tailored panels protect the side walls and wheel arches. The wooden floor comes in different strength and is available with anti-slip coating.



AFFORDABILITY IN ACTION.

- // Match a Vivaro variant to your specifications
- // Contact your Opel dealership for more details

Every Vivaro is a model of efficiency, but other parameters vary from van to van.

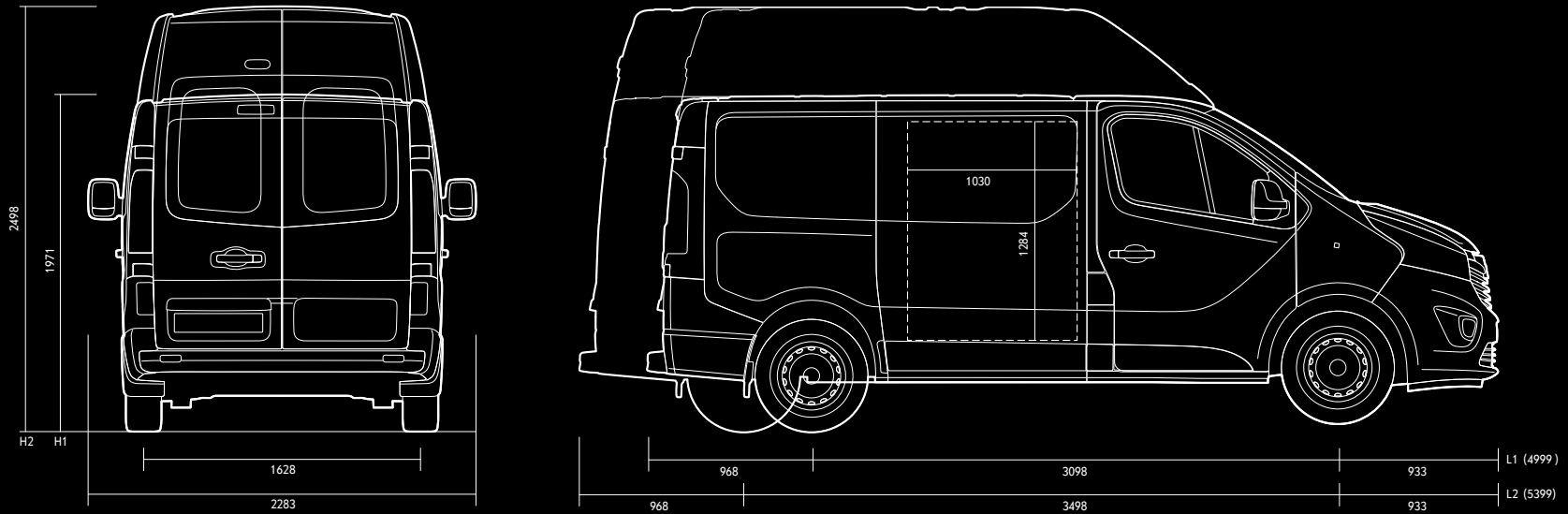

All dimensions in mm.

VARIANTS

LENGTHS AND HEIGHTS		PANEL VAN	CREW VAN	COMBI	PLATFORM CAB
L1	H1	•	•	•	–
	H2	•	–	–	–
L2	H1	•	•	•	•
	H2	•	–	–	–

• = available – = not available

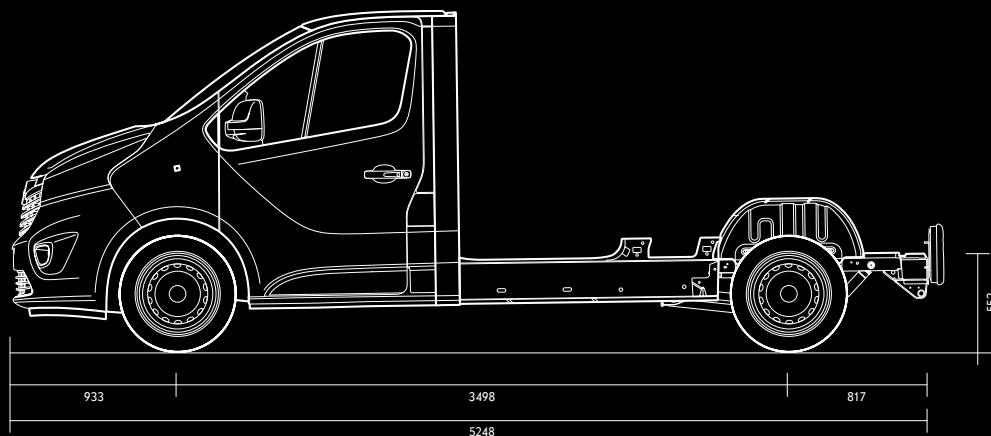
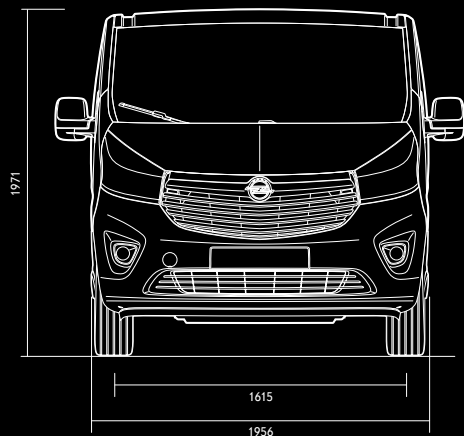

CARGO CAPACITIES

Opel Vivaro body versions	Weight Class (in kg)	Gross Vehicle Weight (in kg)	Number of Seats	Max. Payload (in kg)	Max. Roof Load (in kg)	Max. Load Volume (in m ³)	Max. Load Compartment Floor Length (in mm)	Load Floor Width Max./ Between Wheel Arches (in mm)	Max. Load Compartment Height (in mm)	Turning Circle (Kerb to Kerb/ Wall to Wall) (in m)
Panel Van										
L1H1	2,700	2,780–2,820	2–3	1,006	200	5.2	2,537	1,662/1,268	1,387	11.84/12.4
L1H1	2,900	2,940–2,980	2–3	1,168	200	5.2	2,537	1,662/1,268	1,387	11.84/12.4
L1H2	2,900	2,960–2,980	2–3	1,085	150	7.2	2,537	1,662/1,268	1,897	11.84/12.4
L2H1	2,900	3,000–3,040	2–3	1,205	200	6.0	2,937	1,662/1,268	1,387	13.17/13.73
L2H2	2,900	3,040–3,070	2–3	1,125	150	8.6	2,937	1,662/1,268	1,897	13.17/13.73
Crew Van										
L1H1	2,700	2,820–2,835	5–6	905	200	3.2	2,000	1,662/1,268	1,387	11.84/12.4
L1H1	2,900	2,832–2,844	5–6	914	200	3.2	2,000	1,662/1,268	1,387	11.84/12.4
L2H1	2,900	2,940–2,950	5–6	965	200	4.0	2,400	1,662/1,268	1,387	13.17/13.73
Combi										
						6-seater/9-seater	6-seater/9-seater			
L1H1	2,700	2,760–2,960	2–9	1,095	200	3.2/1.0	1,679/765	1,662/1,268	1,387	11.84/12.4
L1H1	2,900	2,870–2,970	2–9	1,095	200	3.2/1.0	1,679/765	1,662/1,268	1,387	11.84/12.4
L2H1	2,900	2,965–3,020	2–9	1,103	200	4.0/1.8	2,079/1,165	1,662/1,268	1,387	13.17/13.73
Platform Cab										
L2H1	2,900	3,000–3,030	2–3	1,414	–	–	–	–	–	13.17/13.73

Minimum vehicle weight according to type approval, with minimum equipment according to type approval. Max. payload already takes the weight of the driver into account.

ENGINES AND TRANSMISSIONS.

High-tech diesel engines deliver excellent performance, fuel consumption and emissions.
Advanced technologies like BiTurbo reduce operating costs, irrespective of payload.

ENGINES AND TRANSMISSIONS

Engines	1.6 CDTI 95 ¹ with BlueInjection technology	1.6 CDTI 120 ^{1,2} with BlueInjection technology	1.6 BITURBO 125 ¹ with BlueInjection technology	1.6 BITURBO 145 ¹ with BlueInjection technology
Power in kW (hp)/at rpm	70 (95)/3,500	89 (120)/3,500	92 (125)/3,500	107 (145)/3,500
Torque in Nm/at rpm	260/1,500	300/1,750	320/1,500	340/1,750
Transmission	MT-6	MT-6	MT-6	MT-6
Emission standard	Euro 6	Euro 6	Euro 6	Euro 6

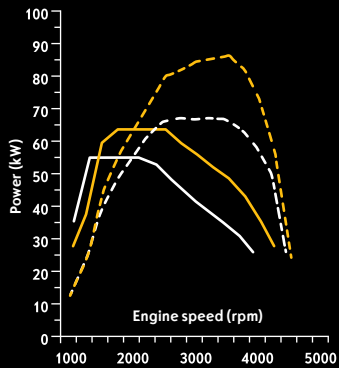

1.6 CDTI 120
// 300 Nm at 1,750 rpm
// 89 kW (120 hp) at 3,500 rpm

1.6 CDTI 95
Torque
Power

1.6 CDTI 120
Torque
Power

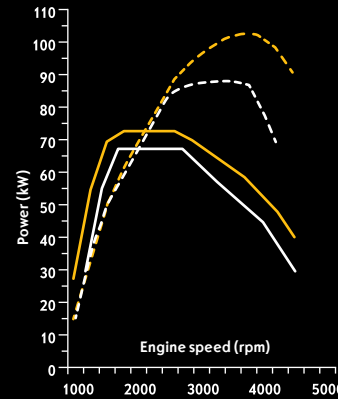

1.6 BITURBO
// More power and torque per cc
// Constant power development

1.6 BITURBO 125
Torque
Power

1.6 BITURBO 145
Torque
Power



BITURBO ENGINES

- // Twin intercooler for clean, efficient combustion
- // Lag-free acceleration at any speed, with any payload
- // Available with Start/Stop System, standard on Combi

QUIET, CLEAN AND EFFICIENT DIESEL ENGINES

- // Optimised thermal and oil pump management
- // Maintenance-free chain drive and particle filter
- // Multi-point fuel injection for low emissions and high performance
- // Service intervals up to 2 years/40,000 km

CONSUMPTION AND EMISSIONS

Engines	1.6 CDTI 95 ^{1,2} with BlueInjection technology	1.6 CDTI 95 ECOFLEX ¹ with BlueInjection technology and Start/Stop System	1.6 CDTI 120 ^{1,2} with BlueInjection technology	1.6 BITURBO 125 ECOFLEX ¹ with BlueInjection technology and Start/Stop System	1.6 BITURBO 145 ECOFLEX ¹ with BlueInjection technology and Start/Stop System
---------	---	--	--	--	--

Table shows scale of consumption and emission data depending on variants and tyres. Please contact your Opel dealer or refer to price list for specific information.

Fuel	Diesel	Diesel	Diesel	Diesel	Diesel
Fuel consumption in l/100 km³					
Urban	Combi (M1)	7.0–6.8			6.5–6.4
	Panel Van H1/H2 (N1)	8.0–7.8	7.3–7.2	8.0–7.8	7.0–6.9/7.4–7.3
	Crew Van (N1)	8.0	7.3	8.0	7.0
Extra-urban	Combi (M1)		5.6–5.4		5.3–5.1
	Panel Van H1/H2 (N1)	6.0–5.8	5.8–5.6	6.0–5.8	5.6–5.5/6.6–6.5
	Crew Van (N1)	6.0	5.8	6.0	5.6
Combined	Combi (M1)		6.1–6.0		5.7–5.6
	Panel Van H1/H2 (N1)	6.7–6.5	6.3–6.1	6.7–6.5	6.1–6.0/6.9–6.8
	Crew Van (N1)	6.7	6.3	6.7	6.1
CO₂ emission in g/km³					
Combined	Combi (M1)		159–155		149–145
	Panel Van H1/H2 (N1)	174–170	164–160	174–170	159–155/178–175
	Crew Van (N1)	174	164	174	159

MT-6 = 6-speed manual transmission M1 = EU vehicle classification for vehicles for passenger carriage only N1 = EU vehicle classification for light commercial vehicles with a gross vehicle weight of up to 3.5 t

All information was accurate and up to date at the time of going to print. The company reserves the right to alter engine specifications at any time, which may influence the content of the shown data. Please consult your Opel dealer for the latest information. M1: all figures quoted relate to the EU base model with standard equipment. Fuel consumption data and CO₂ emission data are determined according to regulations R (EC) No. 715/2007 and R (EC) No. 692/2008 (in the versions respectively applicable), taking into consideration the vehicle weight in running order, as specified by the regulations. Additional equipment and factory-fitted options may lead to slightly higher results than the stated consumption and CO₂ figures. The figures for fuel consumption and CO₂ emissions do not relate to a specific vehicle and are not part of an offer. They are provided only for the purpose of comparison between different vehicles but may differ from the actual fuel consumption achieved in real-world driving conditions which are greatly influenced by driving style and operating conditions. Additional equipment and factory-fitted options may increase the weight of the vehicle when empty and in some cases the permissible axle weights as well as the permissible total weight of the vehicle and reduce the permissible towing weights. This may lead to a reduction in top speed and increased acceleration time. Driving performance figures assume a 75 kg driver plus a 125 kg load. N1: fuel consumption data and CO₂ emission data are determined according to regulations R (EC) No. 715/2007 and R (EC) No. 692/2008 (in the versions respectively applicable). The figures for fuel consumption and CO₂ emissions do not relate to a specific vehicle and are not part of an offer. They are provided only for the purpose of comparison between different vehicles but may differ from the actual fuel consumption achieved in real-world driving conditions which are greatly influenced by driving style and operating conditions. Additional equipment and factory-fitted options may increase the kerb weight of the vehicle and impact the payload. This may lead to a reduction in top speed and increased acceleration time. Driving performance figures assume a 75 kg driver plus a 125 kg load.

¹Vehicles with BlueInjection technology will need regular AdBlue® top-ups also in between recommended service intervals. An indicator integrated into the on-board computer will warn you when you need to top up. For more information, please visit your local official Opel website. ²Only available on vehicles with N1 type approval. ³In acc. with regulations R (EC) No. 715/2007 and R (EC) No. 692/2008 (in the versions respectively applicable).

BIG STEPS. SMALL FOOTPRINT.

Opel is committed to reducing the impact of vehicles on the environment.

ECOFLEX SUSTAINABLE TECHNOLOGIES

- // Reduced emissions of harmful nitrogen oxides (NO_x) with BlueInjection system
- // Reduce fuel consumption to cut operating costs
- // Achieve high mileage with a low carbon footprint
- // BiTurbo models include Eco Mode for maximum efficiency

ECO MODE

- // Optimises key system settings
- // Prompts driver to drive more efficiently
- // Summarises consumption after each trip

START/STOP

- // Saves fuel and emissions
- // Cuts/restarts the engine when appropriate

SMART CHARGING

- // Reuses energy recovered from braking
- // Reduces fuel consumption

The logo for Opel's ecoFLEX technologies. The word "eco" is written in a lowercase, rounded, metallic font with a 3D effect. The word "FLEX" is written in a bold, uppercase, metallic font with a 3D effect, positioned to the right of "eco".



TRIMS AND SURFACES.

A smart van interior says a lot about your business.

- // Impress passengers with attractive combinations
- // Project an excellent business image
- // Rely on hard-wearing materials

TRICISS BLUE/DINO TRIM



Triciss Blue seat insert fabric in Denim Blue.

Dino bolster fabric in Denim Black.

CONNECT BLACK EMBOSSED/JEANNO TRIM



Jeanno bolster fabric in Jet Black.



Connect Black Embossed seat insert fabric in Jet Black.

PAINTS AND WHEELS.

Stylish, hard-working vans deserve paints and wheels to match.

- // Stylish colours and wheels cement your company image
- // Colours are best viewed at your local dealership
- // Wheels are variant-specific

SOLID



Casablanca White



Iron Grey



Spring Green



Ink Blue

METALLIC



Panorama Blue



Midnight Black



Cassiopeia Silver



Copper Brown

BRILLIANT



Magma Red



16" steel wheel with centre cap, 6 J x 16" (P91), tyres 205/65 R 16¹.



16" steel wheel with full-size 10-spoke cover, 6 J x 16" (QP9), tyres 215/65 R 16.



17" alloy wheel, 6 J x 17" (RS6), tyres 215/60 R 17.

METALLIC



Jasper Brown



Platinum Silver

WHEELS

Dimension	205/65 R 16	215/65 R 16	215/60 R 17
Tyre Fuel Efficiency Rating	E-C	C	C
Tyre Wet Grip Rating	E-B	B	B
Tyre Noise Rating (dB)	72-71	70	70
Sound Class			

¹Tyres 205/65 R 16 not available for Combi.





TAKING CARE OF BUSINESS.

FlexCare is the all-encompassing Vivaro service programme. It's integrated and customisable to new owners' needs.

FLEXCARE INCLUDES

- // Guaranteed mobility for peace of mind
- // Free roadside assistance
- // Individually tailored cover
- // Warranty extension to three, four or five years
- // Up to five-year annual service plan
- // Up to five year wear and tear coverage

Ask your local Opel dealership for details.

SUPERIOR SERVICE.

myOpel is an outstanding web portal for maintenance, booking appointments and more. Access it online, and download the optional app.

- // Service offers tailor-made for you and your car
- // Reminders whenever it's time for a service
- // Service requests and easy booking online
- // A dealer locator to find your nearest Opel retailer
- // Online access to your full service history

REGISTER FOR MYOPEL WITH THESE EASY STEPS:

1. Go to www.myOpel.com
2. Register for free and confirm your account
3. Download the optional myOpel app





OPEL FOR LIFE.

Opel keeps you on the road for the lowest cost possible. 24/7, 365 days a year.

OUR SERVICE OFFERS

- // Comprehensive after-sales programmes
- // Customisable FlexCare package for business

STANDARD OPEL WARRANTY

- // 24 months, no mileage limit, 12-year anti-perforation warranty
- // 6,000 Opel service points, 2,000 commercial vehicle service centres
- // Includes Opel Roadside Assistance for first 12 months in 40 countries
- // Opel Original spare parts guaranteed

INNOVATIONS THAT MEAN BUSINESS.

Opel innovations make our vans more efficient, safer, more versatile and more productive. They are more comfortable to drive, work and ride in throughout the year.



LED DAYTIME RUNNING LIGHTS. LED lights deliver better visibility and make your van more visible to other drivers. These stylish headlamps are always on. For more information, turn to page 29.



DEAD ANGLE LENS. Blind angle mirror in co-driver sunblind provides better orientation in limited space conditions. For more information, turn to page 37.



REAR VIEW CAMERA. In combination with the park sensor, this dash-mounted screen helps you avoid low obstacles when reversing. For more information, turn to page 37.



BITURBO TECHNOLOGY. Opel BiTurbo engines use a sequential double turbo system to eliminate turbo lag and deliver smooth acceleration even at low revs. For more information, turn to page 47.



BLUETOOTH® AND USB. Seamless connectivity comes standard with every Opel supplied radio or infotainment system in every new Vivaro. Ideal for accessing portable digital devices. For more information, turn to page 37.



FLEXCARGO® BULKHEAD. This clever bulkhead has a load-through hatch under the front bench that effectively lengthens the load space on the passenger side to 4.15 metres. For more information, turn to page 17.



MOBILE OFFICE. A combination of practical features such as the front office bench seat that converts into a removable clipboard, hidden storage and stable desk for a laptop. For more information, turn to page 34.



www.opel.com

Some illustrations in this brochure contain special equipment not included in standard delivery. The information contained in this brochure was accurate at the time of going to print. We reserve the right to make changes in design and equipment. The colours printed in the brochure only approximate actual colours. Illustrated optional equipment is available at extra charge. Availability, technical features and equipment provided on our vehicles can vary outside of the Federal Republic of Germany. Recycling: information on Design for Environment, our take-back network and the recycling of End of Life Vehicles can be found on www.opel.com. For precise information on the equipment provided on our vehicles, please contact your local Opel partner.

Opel Southeast Europe LLC (2040 Budaörs, Szabadság út 117, Hungary)