



A3 Sportback e-tron



Changes Not everyday life.

An introduction to electromobility. Explore a new world. With the Audi A3 Sportback e-tron. The premium compact car with a plug-in hybrid drive. Dynamic, efficient and ideal for everyday driving.

The figures for fuel and power consumption as well as for CO₂ emissions can be found on page 58.

the world.

The best of both worlds. 4
The Audi A3 Sportback e-tron

Go further. 8
Range – a crucial asset

Two engines do more. 14
Efficient dynamics

The mobility of the future. 20
Brilliant perspectives

Charging made simple. 26
The charging concept for the Audi A3 Sportback e-tron

Highlights. 34
e-tron-specific equipment and attractive packages

Customised and versatile. 44
Further equipment and accessories

Technical data. 56

The best of both worlds.

The advantages of an electric drive combined with the strengths of a combustion engine. The Audi A3 Sportback e-tron embodies the best of both worlds. High efficiency, emission-free driving with the electric motor, sporty driving dynamics, large range and numerous charging options at home and on the road.



The figures for fuel and power consumption as well as for CO₂ emissions can be found on page 58.

A3 Sportback e-tron





Clearly an A3. But a special one. Immediately recognisable thanks to e-tron-specific details. From the radiator grille in black matt with horizontal chrome struts to the diffuser with chrome trim. Then there's the signature light in the front bumper exclusive to e-tron, stylish side sills and exclusive cast aluminium wheels in 15-spoke turbine design, partly polished¹, in a harmonising colour on request.

The figures for fuel and power consumption as well as for CO₂ emissions can be found on page 58.

¹ Please note the special information relating to wheels on page 59.





Go further.

Range – a crucial asset.

This is no everyday vehicle. But one that will prove ideal – day in, day out. The Audi A3 Sportback e-tron drives up to 50 kilometres in purely electric mode. Enough range for many trips. And the combination of combustion engine and electric motor allows you to cover long distances with confidence.

The figures for fuel and power consumption as well as for CO₂ emissions can be found on page 58.

The given range can vary depending on driving style, speed, the use of convenience features/secondary consumers, outside temperature, the number of passengers/size of load, driving profile selected and topography.







Switch off and enjoy the peace.

In the Audi A3 Sportback e-tron you can drive in peace and quiet in purely battery-operated mode without the combustion engine. Emission-free. Relax and be good – to yourself and your environment.

The figures for fuel and power consumption as well as for CO₂ emissions can be found on page 58.







**Two engines
do more.**

While consuming less.







Efficient dynamics.

The combination of combustion engine and electric motor quickly impresses: the Audi A3 Sportback e-tron offers a combination of sporty driving performance and impressive efficiency in one. Or in figures: 222 km/h top speed, from 0 to 100 km/h in 7.6 seconds. And all that with low fuel consumption and emissions.

The figures for fuel and power consumption as well as for CO₂ emissions can be found on page 58.



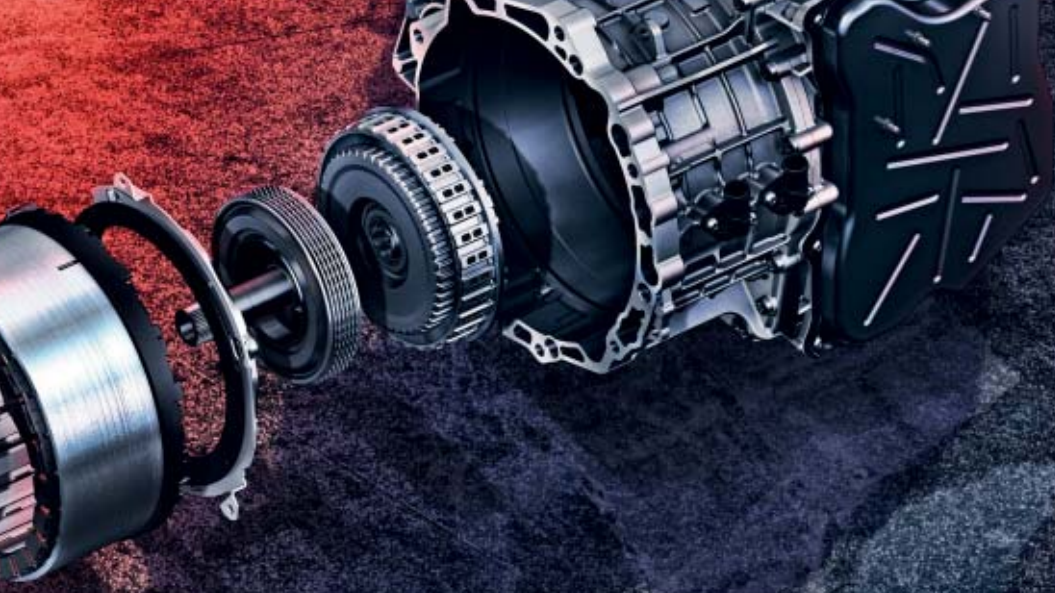

The combustion engine is a powerful and efficient 1.4 TFSI with 110 kW. The disc-shaped electric motor with 75 kW of power is integrated in the 6-speed S tronic that has been designed specially for the A3 Sportback e-tron. It makes its maximum torque available right from the word go for perceptibly dynamic acceleration even in purely electric mode.

The figures for fuel and power consumption as well as for CO₂ emissions can be found on page 58.

A close-up, artistic photograph of a car's interior. The image is dominated by dark, textured surfaces. On the left, a portion of a dashboard or center console is visible, featuring a sleek, modern air vent with a small digital display showing '100'. In the center, a circular air vent with a complex, multi-spoke design is highlighted by a soft red glow. To the right, the perforated texture of a steering wheel is visible. The overall lighting is dramatic, with deep blues and blacks, accented by the red glow and some ambient light from the dashboard.

The mobility of the future.

The figures for fuel and power consumption as well as for CO₂ emissions can be found on page 58.



25% 100%
READY CHARGE OFF MAX POWER

A3 e-tron



26km 0.5km
17:21 +19.5°C

60 160 200 240 280

VIEW
OK

NAV * + -

CAMERA
+ SPEED -
DISTANCE + -



Fahrzeug: Reichweite

Reichweitenpotential:
+ 5 km

Klimatisierung
Heckschaltheizung
Statheizung vorn links

45 km

17:04 A day in the city

45 km A day in the city

Reichweite

45 km

26 km 0.5 km

21.5°C 22.0°C

AUTO AC

P R N D/S

DRIVE

MANUAL

With you at the centre.

Take a seat in the control centre for progressive mobility. In a high-quality interior, as comfortable and generously spacious as ever. The e-tron logo on the door sill trims, selector lever knob and dashboard show you that you are now journeying through a new world. Further proof is provided by the range monitor in the MMI display, keeping you up to date on two counts: about the remaining range in electric mode and how to increase it by switching off inactive secondary consumers such as the automatic air conditioning.

The figures for fuel and power consumption as well as for CO₂ emissions can be found on page 58.



SD A day in the city

45 km



26km 0,5k

17:03

+19,5



Brilliant perspectives.

Audi virtual cockpit – the optional fully digital instrument cluster – presents lots of relevant drive information on a high-resolution 12.3-inch colour display. From the energy flow display and powermeter to the range indicator. Razor-sharp, brilliant and rich in contrast. Either in classic view with large round dials or on the impressive infotainment platform with further functions such as navigation, phone, Audi connect¹ or media.

The figures for fuel and power consumption as well as for CO₂ emissions can be found from page 58 onwards.

¹Legal information and notes on use can be found from page 60 onwards.

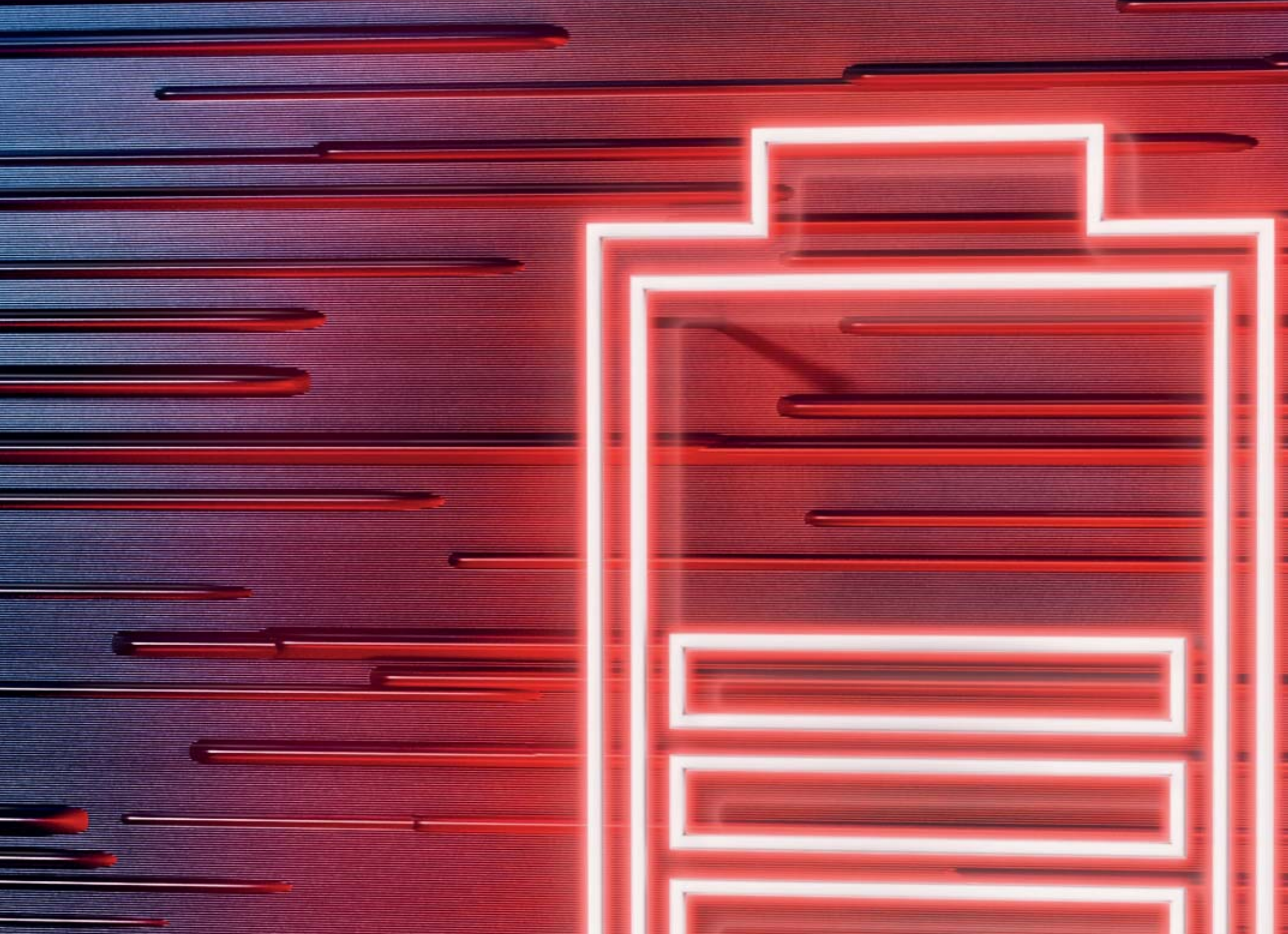

From zero to full in 2¼ hours.

An easy way
to connect.





For fast battery charging, we recommend using an industrial socket. Your Audi partner offers an optional installation service – for a fee, you can book an on-site home check and have the industrial socket installed if necessary. An easy way to turn your parking space into your private charging station. And storing and handling the e-tron charging system is convenient thanks to the optional charging clip or charging dock¹ in the attractive Audi design.

¹The charging dock is available from Audi Genuine Parts.

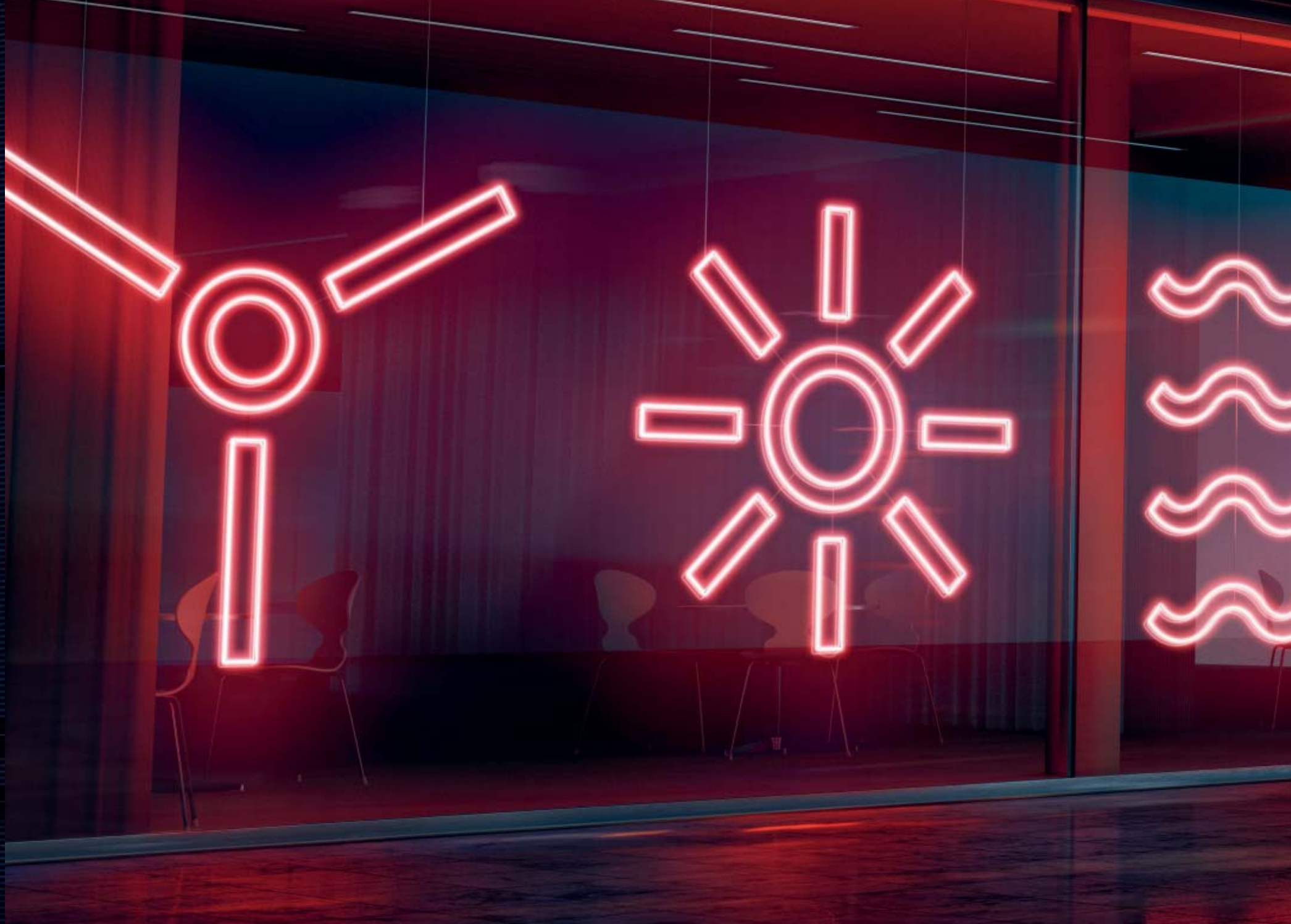



Emissions-free. Naturally.

CO₂-neutral mobility with renewable power. Your Audi partner will help you to sign up with a green energy provider. For emissions-free driving in electric mode and an environmentally-friendly power supply at home.



Charging made simple.

The charging concept for the Audi A3 Sportback e-tron. As advanced as the vehicle itself. With a charging connector concealed behind the four rings in the Audi Singleframe. And charging equipment that is practical and easy to use. When you connect to an industrial socket, it takes less than 2¼ hours to fully charge a completely discharged battery. Just like at public charging stations when you're on the road. Even if you use a domestic socket, the charging process takes less than 4 hours.

The figures for fuel and power consumption as well as for CO₂ emissions can be found on page 58.



Convenience
– remote-controlled
with your smartphone.



The figures for fuel and power consumption as well as for CO₂ emissions can be found on page 58.



Audi connect e-tron services¹ offer you a high level of comfort and convenience even before you start driving. Departure times can be determined using remote-controlled charge planning via the myAudi portal or your smartphone and the Audi MMI connect app, allowing charging to be programmed flexibly. In addition, detailed information about the trip, vehicle status, average power consumption and current battery charge status can be retrieved and you can even trigger the car's climate control remotely, too.

¹Legal information and notes on use can be found from page 60 onwards.

Discover a new world.

The Audi A3 Sportback e-tron is the result of a progressive concept. A car that emphasises its sporty heritage and is breaking new ground. Opening up a new world, dynamically and efficiently. To be experienced here and now.

The figures for fuel and power consumption as well as for CO₂ emissions can be found on page 58.





01

Relaxed. With the e-tron charging equipment.

The e-tron charging system comprises a vehicle cable, control unit and two country-specific connection cables. The full charge can be achieved in the shortest charging time (approximately 2¼ hours) using an industrial socket. Using a domestic socket, it takes around 3¾ hours. The optional wall units, charging clip or charging dock¹ offer convenience when charging at your personal parking space. A special charging cable is optionally available for charging at public charging stations.

The figures for fuel and power consumption as well as for CO₂ emissions can be found on page 58.

01_Vehicle charging connection with current charging status indicated by large LEDs for convenient charging **02**_Charging clip – practical and compact wall unit for the e-tron charging system, includes a separate device to secure the charge plug **03**_Charge dock¹ – visually appealing and lockable wall unit for the e-tron charging system. Can cover up a socket on the wall and can be also optimally suitable for outdoor use **04**_e-tron charging system – for universal use, can be taken along in the vehicle and thus offers flexibility on the road **05**_separate charging cable for public A/C charging stations, which – such as in Europe – are generally not equipped with a permanently attached cable

Some of the equipment illustrated or described is optional equipment for which an extra charge is made. Please contact your Audi partner or visit www.audi.com for detailed information about standard and optional equipment. ¹ Available from Audi Genuine Parts.



02



03



34 35

04



05

Highlights



01



02



03

Versatile. With room for your own ideas.

Progressive and suitable for everyday driving. The Audi A3 Sportback e-tron is ready for a host of challenges. Including the transportation of longer objects thanks to its variably folding rear seat backrest. In addition, the optional trailer towing hitch extends your freedom to further axles if required. And there is still enough room for comfort and elegance, as illustrated by the intuitive MMI touch rotary/push-button control, and the exclusive door sill trims with aluminium inlays and e-tron logo.

The figures for fuel and power consumption as well as for CO₂ emissions can be found on page 58.

01_Folding rear seat backrest for the convenient transportation of long objects **02**_MMI touch rotary/Duo logic push-button control for intuitive operation, including touch-sensitive input area with handwriting recognition **03**_Swivelling trailer towing hitch creates additional flexibility for transportation **04**_e-tron door sill trims produce a fascinating ambience on the interior

Some of the equipment illustrated or described is optional equipment for which an extra charge is made. Please contact your Audi partner or visit www.audi.com for detailed information about standard and optional equipment.

e-tron-specific standard equipment





02



03

More exclusive. With e-tron-specific standard equipment.

The Audi A3 Sportback e-tron – an exceptional vehicle that will win you over with its superb quality and range of equipment options. As standard. As demonstrated by its many highlights, from the deluxe automatic air conditioning and driver information system with high-resolution colour display to the practical Audi connect e-tron services¹.

The figures for fuel and power consumption as well as for CO₂ emissions can be found on page 58.

01 _Deluxe automatic air conditioning with pre-conditioning during the charging process || leather steering wheel in 3-spoke design with multifunction plus || MMI radio plus || Audi drive select offers individual adjustment of vehicle characteristics || driver information system with colour display **02** _EV button for activating the purely electric or hybrid driving mode **03** _Audi connect e-tron services¹, use the Audi MMI connect app and myAudi to control the charging process and climate, monitor the charging status, electric range, vehicle location or get information about recent trips

Some of the equipment illustrated or described is optional equipment for which an extra charge is made. Please contact your Audi partner or visit www.audi.com for detailed information about standard and optional equipment. ¹ Legal information and notes on use can be found from page 60 onwards.



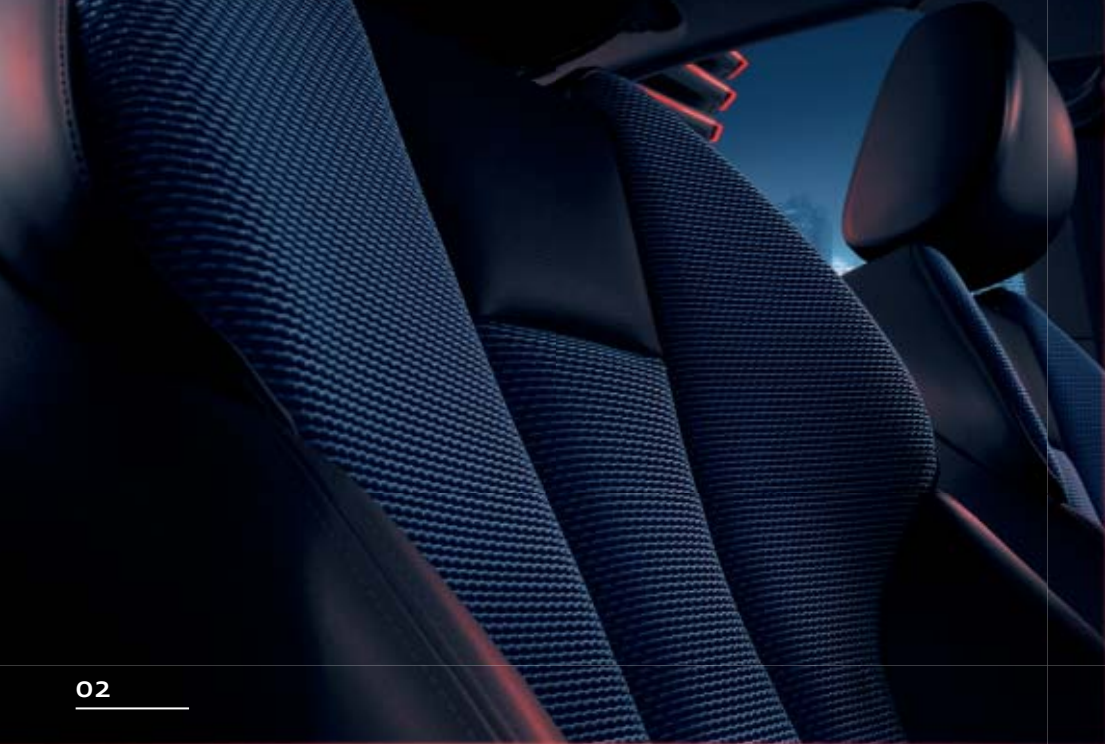

02



03

More exceptional. The Audi design selection.

Make an exceptional vehicle even more exceptional. This can be very stylishly achieved with the Audi design selection, which offers an attractive range of special materials and colours for the interior. The Audi design selection cosmos blue or optionally amaretto brown – both designs come with colour-coordinated contrasting stitching in the interior.

The figures for fuel and power consumption as well as for CO₂ emissions can be found on page 58.

01_Door trim inserts in black leather || centre armrest, front, armrests in the doors and lower part of centre console in black leather with contrasting stitching, floor mats in black with edging in contrasting colour || selector lever knob in leather and gaiter in leather **02**_Sport seats, front || seat side bolsters and head restraints in black leather with contrasting stitching || seat centre panels in plenum cloth black/cosmos blue **03**_Inlays in matt brushed aluminium, design light || further distinguishing features in the interior

Many additional highlights can be found at www.audi.com

Some of the equipment illustrated or described is optional equipment for which an extra charge is made. Please contact your Audi partner or visit www.audi.com for detailed information about standard and optional equipment.

S line sport package

01

02

Sportier. With the S line sport package.

Show your sporty side with the S line sport package – all along the line. With details that impressively emphasise the temperament of your Audi A3 Sportback e-tron and indicate powerful performance at first sight.

The figures for fuel and power consumption as well as for CO₂ emissions can be found on page 58.

01_Optional 18-inch cast aluminium wheels in 15-spoke turbine design, partly polished¹ **02**_S line sport contour leather steering wheel in 3-spoke design with multifunction plus, flattened at the bottom, in black leather with S emblem and steering wheel grips in perforated leather; contrasting stitching on steering wheel, gear gaiter, centre armrest, floor mats, seat upholstery and leather package (if ordered) **03**_optional S sport seats, front, on request with S line seat upholstery in fine Nappa leather, black, with S embossing on the front-seat backrests || interior, dashboard and headlining in black || inlays in matt brushed aluminium || further distinguishing features in the interior

Many additional highlights can be found at www.audi.com

Some of the equipment illustrated or described is optional equipment for which an extra charge is made. Please contact your Audi partner or visit www.audi.com for detailed information about standard and optional equipment. ¹Please note the special information relating to wheels on page 59.



Paint finishes

02

03

04

05

01



Some of the equipment illustrated or described is optional equipment for which an extra charge is made. Please contact your Audi partner or visit www.audi.com for detailed information about standard and optional equipment.
¹ Many additional colours are available on request. From Audi Sport GmbH.

Powerful look.

Select the paint colour that best suits your personality. Secure in the knowledge that the quality will be superb, because your vehicle is painted not just once, but four times. So not only do you look radiant in your Audi, your car is also protected from environmental influences and wear. Ensuring that the car maintains a powerful look throughout its entire lifetime.

The figures for fuel and power consumption as well as for CO₂ emissions can be found on page 58.

Many additional paint finishes can be found at www.audi.com

01_Floret silver, metallic **02**_Ara blue, crystal effect **03**_Tango red, metallic **04**_Daytona grey, pearl effect
05_Glacier white, metallic **06**_Audi exclusive customised paint finish in Java green, metallic¹





01
18"



02
17"



03
18"



04
17"

Powerful appearance.

With Audi wheels, you can emphasise your individual style and the character of your Audi A3 Sportback e-tron. Why not indulge yourself and create a powerful presence with your favourite design. And for peace of mind when out on the road: Audi wheels are subjected to special test procedures, undergo rigorous testing and are of superb quality.

The figures for fuel and power consumption as well as for CO₂ emissions can be found on page 58.



05

17"



06

18"



07

18"



08

18"

01_18-inch cast aluminium wheels in 5-arm dynamic design, contrasting grey, partly polished¹ 02_17-inch cast aluminium wheels in 5-arm kinetic design 03_18-inch Audi Sport cast aluminium wheels in 10-V-spoke design²
 04_17-inch cast aluminium wheels in 5-arm design 05_17-inch cast aluminium wheels in 10-spoke turbine design 06_18-inch cast aluminium wheels in 15-spoke turbine design, partly polished¹
 07_18-inch cast aluminium wheels in multi-spoke design, partly polished¹ 08_18-inch Audi Sport cast aluminium wheels in 10-spoke design in matt titanium look, gloss turned finish^{1,2}

Many additional wheels can be found at www.audi.com

Seats/seat upholstery



01



02

Rallye cloth, black/blue

Regatta cloth/mono.pur, black

Plenum cloth/leather, black/cosmos blue with contrasting stitching

Sequence cloth/leather, black with contrasting stitching

More quality. With the cloth and leather upholstery and trim.

You have a special place in your Audi. Exclusive comfort can be felt on the front and rear seats: thanks to high-quality materials and first-class workmanship. No matter which seat upholstery you choose: you're sitting in the right place.

Many additional seat upholstery options can be found at www.audi.com

03

01_S sport seat, front, in fine Nappa leather, rotor grey with contrasting stitching 02_Sport seat, front, in plenum cloth/leather, black/cosmos blue with contrasting stitching 03_Standard seat, front, in regatta cloth, rock grey

Some of the equipment illustrated or described is optional equipment for which an extra charge is made. Please contact your Audi partner or visit www.audi.com for detailed information about standard and optional equipment.

Frequency Alcantara/leather combination,
black with contrasting stitching

Frequency Alcantara/leather combination,
rotor grey with contrasting stitching

Milano leather, rock grey

Fine Nappa leather, black
with contrasting stitching

Inlays



3D-design "Optic", titanium grey

Aluminium mistral

Some of the equipment illustrated or described is optional equipment for which an extra charge is made. Please contact your Audi partner or visit www.audi.com for detailed information about standard and optional equipment.

¹Inlays illuminated in the doors.

More refined. With the inlays.

Exclusive ambience is a question of style. Your style. A style you can refine right down to the last detail. Create tangible accents with high-quality Audi inlays. Experience the fascination of exclusive materials – fine décors in 3D-design “Optic”, titanium grey, aluminium mistral, silver, micrometallic, silver or matt brushed aluminium, design light¹ – choose the ones that best suit your personal taste.

The figures for fuel and power consumption as well as for CO₂ emissions can be found on page 58.

Additional inlays can be found at www.audi.com.

Micrometallic, silver

Matt brushed aluminium, design light¹

As individual as the life you lead.

The Audi A3 Sportback e-tron has the technology to offer you a new driving experience. Audi Genuine Accessories enhances this unique feeling by providing you with numerous options to further customise your Audi. Products with style and functionality that will win you over, and that keep our quality promises day in, day out.

The figures for fuel and power consumption as well as for CO₂ emissions can be found on page 58.

01_Cast aluminium wheels in 5-arm velum design¹ – in size 7.5 J x 18, ensure a dynamic appearance.

02_Ski and luggage boxes – in exclusive Audi design, can be locked and conveniently opened on both sides. Available in the sizes 300 l, 360 l and 405 l.

03_Cycle mount – allowing easy cycle attachment to the carrier unit. Made of specially moulded aluminium profile, lockable.

04_USB adapter – for charging various mobile phone models in conjunction with Audi phone box².

05_Luggage compartment box, folding – easy to assemble thanks to hook-and-loop tapes. Can also be flattened and used as additional protection.

06_Exterior mirror caps in carbon – eye-catchers that also save weight



You will find further information in the accessories catalogue, at www.audi.com, and from your Audi partner.

¹Please note the special information relating to wheels on page 59. ²Please contact your Audi partner or visit www.audi.com/bluetooth for information on compatible mobile phones.



01



02



03

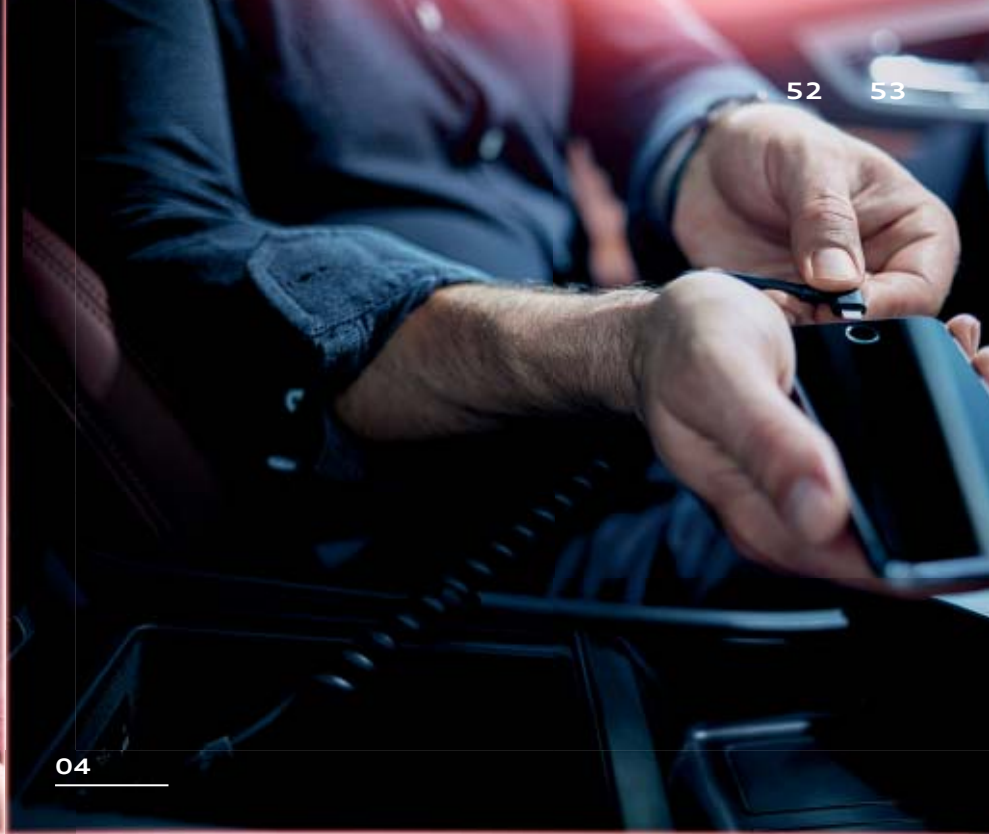

52

53

04



05



06

The fascination of Audi

The fascination of the Audi A3 Sportback e-tron. Find out more online.

Discover the world of the Audi A3 Sportback e-tron. More information, more individuality and more exclusivity. Now at www.audi.com.

The figures for fuel and power consumption as well as for CO₂ emissions can be found on page 58.

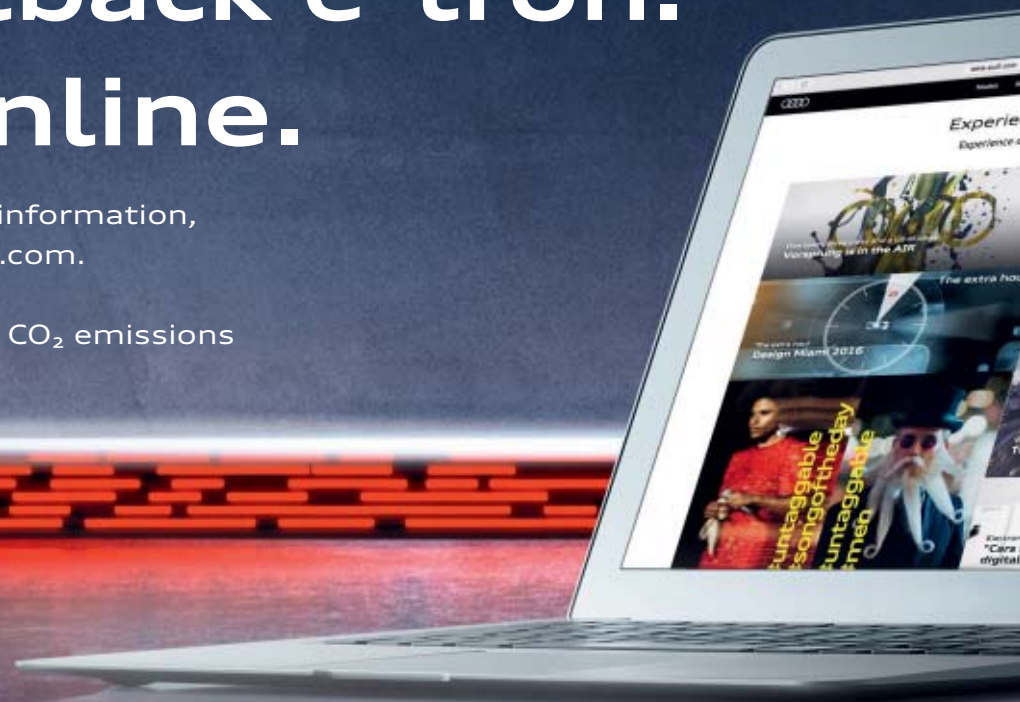

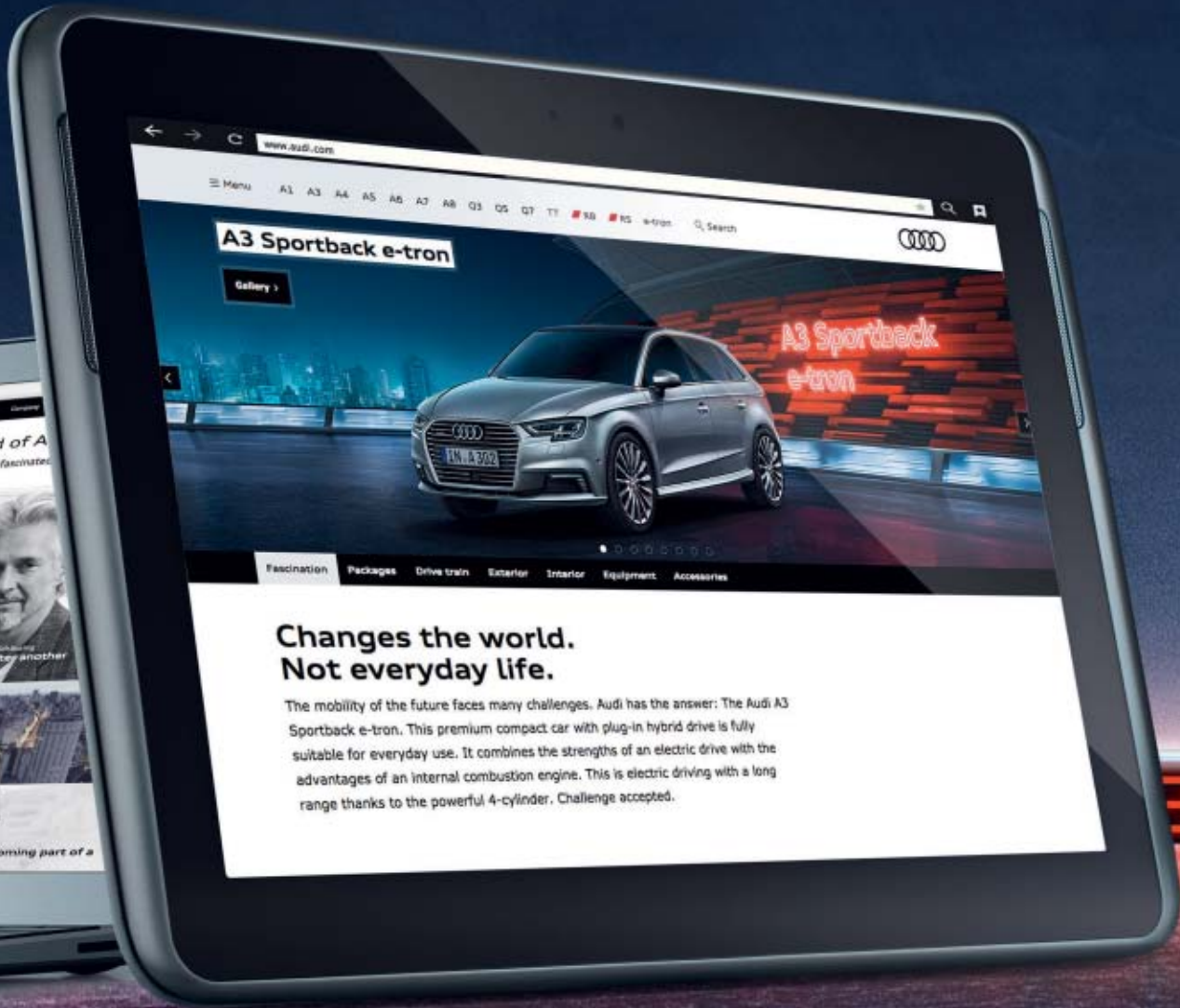

**Changes the world.
Not everyday life.**

The mobility of the future faces many challenges. Audi has the answer: The Audi A3 Sportback e-tron. This premium compact car with plug-in hybrid drive is fully suitable for everyday use. It combines the strengths of an electric drive with the advantages of an internal combustion engine. This is electric driving with a long range thanks to the powerful 4-cylinder. Challenge accepted.



Scan the QR code using a smartphone or tablet and explore the world of the Audi A3 Sportback e-tron. Connection costs depend on your mobile phone contract

Go further.

The given range can vary. In practice, this value depends on the influence of different factors. The following table illustrates the effects the most important factors in daily driving have on range.



Influencing Factors

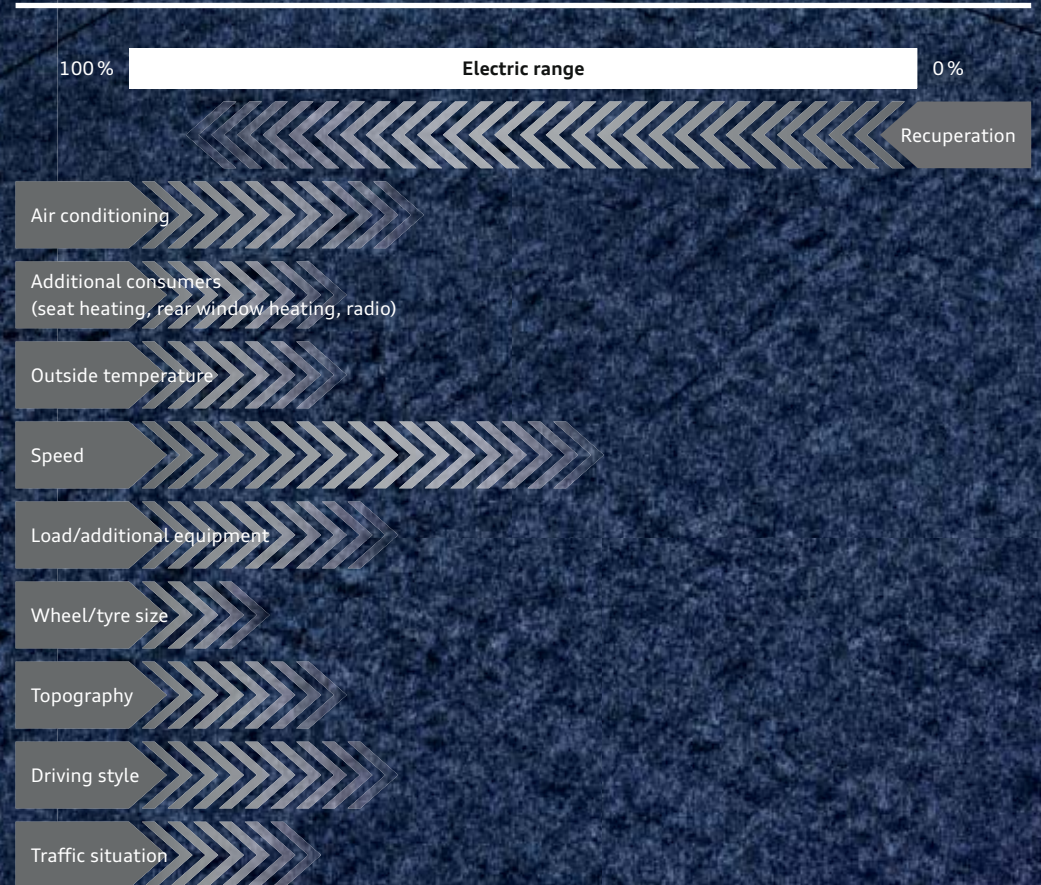

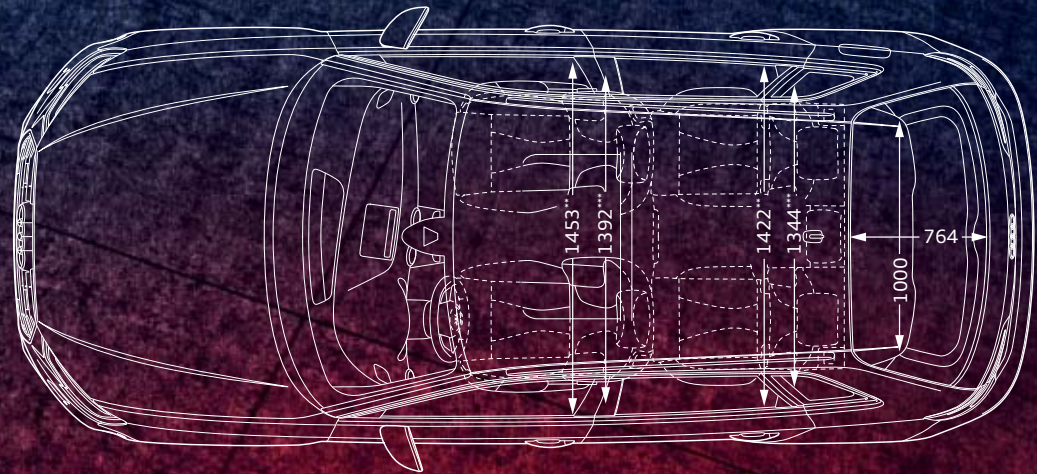
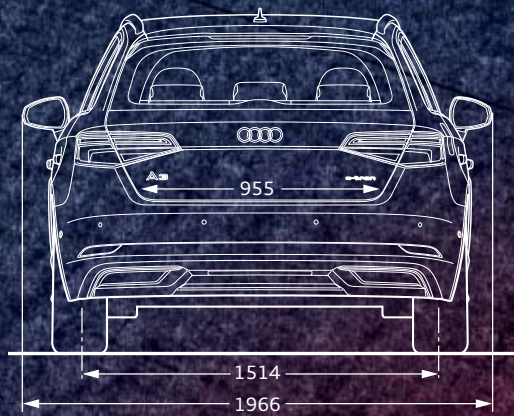
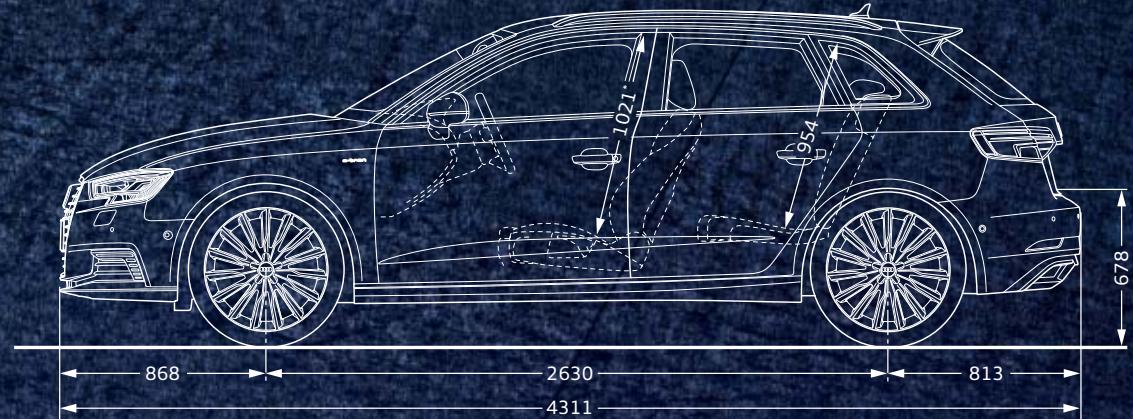
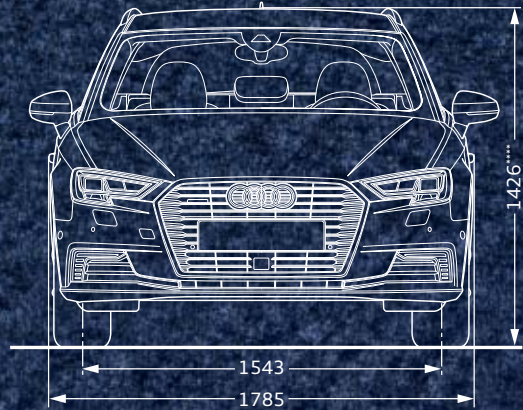

Dimensions in millimetres

Dimensions are for unladen vehicle weight. Luggage capacity¹ in l: 280/1,120 (second value with the rear seat backrest folded down and vehicle loaded up to roof height). Turning circle approx. 10.9 m.

*Maximum headroom. **Elbow room width. ***Shoulder room width.

¹Technical specifications refer to a basic vehicle without country-specific basic equipment and the selected optional equipment.













Technical data

Model	Audi A3 Sportback e-tron 1.4 TFSI (110 kW)
Engine type	4-cylinder inline petrol engine with direct fuel injection, turbocharging and indirect intercooling
Displacement in cc (valves per cylinder)	1,395 (4)
Max. output ¹ of combustion engine in kW at rpm	110/5,000–6,000
Max. torque in Nm at rpm	250/1,600–3,500
Plug-in hybrid drive	
Electrical output in kW	75 ²
Max. electrical torque in Nm	330 ²
System output in kW	150 ²
Overall system torque in Nm	350 ²
Battery type	Lithium-ion battery system
Battery energy content in kWh	8.8
Power transmission	
Drive type	Front-wheel drive
Transmission type	6-speed S tronic with integrated electric motor
Weights/capacities	
Unladen weight ³ in kg	1,615
Gross vehicle weight in kg	2,050
Permissible roof load limit/nose weight in kg	75/75
Trailer load limit ⁴ in kg	
unbraked	750
12% gradient	1,400
8% gradient	1,600
Fuel tank capacity, approx. in l	40

Model	Audi A3 Sportback e-tron 1.4 TFSI (110 kW)
Performance	
Top speed electric in km/h	130
Top speed hybrid in km/h	222
Acceleration electric 0–60 km/h in s	4.9
Acceleration hybrid 0–100 km/h in s	7.6
Performance/consumption⁵	
Fuel grade	Sulphur-free super RON 95 ⁶
Power consumption combined in kWh/100 km	12.0–11.4
Fuel consumption ^{7, 8} in l/100 km combined	1.8–1.6
CO ₂ emissions ^{7, 8} in g/km combined	40–36
Range, electric, in km	up to 50 ⁹
Emission standard	EU6

Classifications of tyre parameters

The table shows the range of fuel efficiency, wet grip and exterior noise emission classes for the different tyre sizes of the Audi A3 Sportback e-tron.

	Tyre size	Fuel efficiency class	Wet grip class	Exterior noise emission class
Summer tyres	205/55 R 16	A	B	71 
	225/45 R 17	B	A	71 
	225/40 R 18	F-C	B-A	72-67  - 
	235/35 R 19	E-C	B-A	72-68  - 
Winter tyres	205/55 R 16	E	C-B	72-68  - 
	205/50 R 17	F-E	E-B	71-68  - 
	225/40 R 18	E	C-B	72-70  - 

It is not possible to order a specific tyre. Ask your Audi partner about the range of tyres available in your country.

Equipment for the Audi A3 Sportback e-tron illustrated (p. 4–33):

Paint finish: floret silver, metallic

Wheels: cast aluminium wheels in 15-spoke turbine design, partly polished¹⁰

Seats/seat upholstery: S sport seats, front, in fine Nappa leather, black with contrasting stitching in rock grey¹¹

Inlay: matt brushed aluminium, design light¹²

Explanatory notes

- ¹ The figure given was calculated using the specified measuring procedure (current version of UN-R 85).
- ² Briefly.
- ³ Unladen vehicle weight includes driver (75 kg) and fuel tank 90 % full, calculated in accordance with the current version of Reg. (EU) 1230/2012. Optional equipment may increase the vehicle's unladen weight and drag coefficient, whereupon the possible payload limit and the top speed will be reduced accordingly.
- ⁴ The engine's power output always decreases with increasing altitude. At 1,000 m above sea level, and for every additional 1,000 m, deduct 10 % from the weight of the outfit (trailer load limit + gross weight of the towing vehicle). Figure for trailer load limit applies to factory-fitted trailer towing hitch. If using the vehicle with a trailer towing hitch for commercial purposes, a digital tachograph may be required under certain conditions.
- ⁵ Fuel consumption and CO₂ emission figures given in ranges depend on the tyre/wheel sets used.
- ⁶ We recommend using sulphur-free super unleaded RON 95 fuel complying with DIN EN 228. If this is not available, use sulphur-free regular unleaded RON 91 fuel complying with DIN EN 228; power output will be slightly reduced. Unleaded RON 95 fuel with a maximum ethanol content of 10 % (E10) can generally be used. Fuel consumption details refer to operation with RON 95 fuel complying with 692/2008/EC.
- ⁷ The figures given were calculated using the specified measuring procedures. The figures do not refer to one individual vehicle and do not form part of any offer, but rather should be used purely for purposes of comparison between the different vehicle models.
- ⁸ A vehicle's fuel consumption and CO₂ emissions depend not just on how efficiently the vehicle uses the fuel, but are also influenced by driving behaviour and other non-technical factors. CO₂ is the greenhouse gas primarily responsible for global warming.
- ⁹ The given range can vary depending on driving style, speed, the use of convenience features/secondary consumers, outside temperature, the number of passengers/size of load, selection of driving profile and topography.
- ¹⁰ Please note the special information relating to wheels given below.
- ¹¹ Only available in conjunction with S line sport package.
- ¹² Inlays illuminated in the doors.

Important note

Special information about the wheels: Wheels with gloss turned or gloss milled finish as well as polished or partly polished aluminium wheels must not be used in wintry road conditions. For manufacturing reasons, the wheel rim surface does not have sufficient corrosion protection for such use and can be permanently damaged by road salt or similar.

Legal notices about Audi connect navigation & infotainment with customer SIM card

The use of services supported by Audi connect is possible only in conjunction with an optional navigation system and Audi connect (including car phone – depending on the vehicle model). Depending on the vehicle model, you also require a SIM card with data option and with LTE option to use LTE¹ – a SIM card with phone and data option or a Bluetooth-capable smartphone with remote SIM Access Profile (rSAP)² is required to use the integrated car phone function. The services are available only in conjunction with an existing or separate mobile phone contract and only within the range of the respective the mobile phone network. Additional costs may be incurred when receiving data packets from the internet, depending on the terms of your mobile phone contract, particularly when used abroad. Because of the high data volumes involved, a data flat rate is strongly recommended.

The availability of the services supported by Audi connect navigation & infotainment varies from country to country. The Audi connect services are provided for at least 1 year from vehicle delivery. 24 months after vehicle delivery, the Audi connect services will be extended once free of charge for 12 months. If you do not require this extension, please write to:

AUDI AG
Audi International Customer Care Services
85045 Ingolstadt, Germany
Email: kundenbetreuung@audi.de
Tel.: +49 800 28347378423

Ask your Audi partner about a subsequent extension of the Audi connect services. Depending on the vehicle model, Audi connect enables access to Google and Twitter services. Permanent availability cannot be guaranteed; Google and Twitter are responsible for this. Please visit www.audi.com/connect or contact your Audi partner for more detailed information about Audi connect; contact your mobile services provider for information about contract conditions.

Legal notices about Audi connect navigation & infotainment with SIM card permanently installed in the vehicle

Use of the services supported by Audi connect is possible only in conjunction with an optional navigation system. Audi connect services are provided through AUDI AG. The data connection for Audi connect services is set up through a mobile services provider via a SIM card permanently installed in the vehicle. The costs for these data connections are included in the price of Audi connect services. The costs for the Wi-Fi hotspot are not included. The data connection for the Wi-Fi hotspot can be arranged with a selected mobile services provider as a payable data tariff. You will find information about tariffs and booking at www.audi.com/myaudi.

Alternatively, a customer SIM card can be inserted into the card slot to establish a data connection. In conjunction with the optional Audi phone box, a Bluetooth-capable smartphone with remote SIM Access Profile (rSAP)² can also be connected to use the integrated car phone function. If an external SIM card is inserted into the card slot or connected via rSAP, all data connections, for both the Audi connect services as well as for the Wi-Fi hotspot, will be established via this external SIM card. In such cases, the costs incurred are attached to those accrued via the external SIM card.

The availability of the services supported by Audi connect navigation & infotainment varies from country to country. The Audi connect services are provided for at least 1 year from vehicle delivery.³ 24 months after vehicle delivery, the Audi connect services will be extended free of charge once for 12 months. If you do not require this extension, please write to:

AUDI AG
Audi International Customer Care Services
85045 Ingolstadt, Germany
Email: kundenbetreuung@audi.de
Tel.: +49 800 28347378423

Ask your Audi partner about a subsequent extension of the Audi connect services. Depending on the vehicle model, Audi connect enables access to Google and Twitter services. Permanent availability cannot be guaranteed; Google and Twitter are responsible for this. Please visit www.audi.com/connect or contact your Audi partner for more detailed information about Audi connect; contact your mobile services provider for information about contract conditions.

¹ Full use requires an LTE card contract. For information about the availability and use of LTE support, please contact your Audi partner. ² Please contact your Audi partner or visit www.audi.com/bluetooth for information on compatible mobile phones. ³ The teaser phase offered by AUDI AG with the equipment “Audi connect navigation & infotainment with integrated SIM card (3 months)” is available for 3 months from initial vehicle registration and ends automatically at the end of these 3 months. If the licence is purchased for Audi connect navigation & infotainment, these 3 months are not offset against the overall validity period for the Audi connect services.

⁴ Depending on country-specific availability. ⁵ Compatible from Apple iOS 7 and Android 4.1. Prior registration at www.audi.com/myaudi is required. Active Wi-Fi connection between smartphone and Audi MMI for online media streaming required.

Legal notices about Audi connect e-tron services

The services are provided via a SIM card installed in the vehicle. The costs for data connections are included in the price of the services. Audi connect services are available only within the range of the selected mobile phone network operated by Audi's chosen mobile phone provider. In order for the services to be provided, the mobile phone network required for the installed SIM card must function correctly and be operationally ready. The Audi connect e-tron services are available for 10 years after vehicle delivery in the following countries:

Austria, Belgium, Bulgaria, Croatia, Czech Republic, Denmark, Estonia, Finland, France, Germany, Greece, Greenland, Hungary, Ireland, Italy, Latvia, Liechtenstein, Lithuania, Luxembourg, Malta, Monaco, the Netherlands, Norway, Poland, Portugal, Romania, Slovakia, Slovenia, Spain, Sweden, Switzerland, Turkey, the UK.

A compatible smartphone with the Audi MMI connect app^{4,5} is required for the use. The app is available free from the Apple App Store and Google Play Store.

General legal notice about the equipment Audi connect e-tron services and Audi connect

Disruption to the services may occur due to force majeure and official orders as well as technical and other measures carried out on the systems of AUDI AG, suppliers or network operators to ensure their proper function (e.g. maintenance, repair, system-related software updates, extensions). AUDI AG will make every reasonable effort to end such disruption immediately or to work towards a resolution.

AUDI AG

Auto-Union-Strasse 1
85045 Ingolstadt
www.audi.com
Date published:
April 2017

Printed in Germany
733/1151.30.18

The vehicles and equipment versions illustrated and described in this catalogue and some of the services listed are not available in all countries. Some of the cars illustrated are equipped with optional features for which an extra charge is made. Details concerning the delivery specifications, appearance, performance, dimensions and weights, fuel consumption and running costs of the vehicles were correct to the best of our knowledge at the time of going to press. Deviations from the colours and shapes shown in the illustrations may occur. No liability is accepted for errors and printing errors. The right to introduce modifications is reserved. Not to be reproduced, including in part, without the written approval of AUDI AG.

This catalogue is printed on paper made from pulp bleached without the use of chlorine.

