

RS 7



Audi Sport



	Page	
Fascination		
	4	Audi RS7 Sportback
Technology		
	22	Innovations
	24	Audi Sport
	26	Performance
	28	quattro®
	30	Dynamics
	32	Audi drive select
Equipment		
	36	Style guides
	38	Paint finishes
	40	Wheels/tyres
	42	Seats
	45	Headlinings
	46	Inlays
	48	Equipment packages
	48	Lights
	48	Design
	49	Steering wheels/controls
	50	Comfort
	51	Infotainment
	53	Assistance systems
	55	Technology/safety
	55	Audi Extended Warranty
Other		
	56	Technical data
	57	Dimensions
	58	Index
	64	The fascination of Audi

The equipment for the vehicle illustrated in the Fascination section can be found on page 62.
 The fuel consumption and CO₂ emission figures can be found on page 56.

Unconditional dynamism. With prestige.

■ Puristic elegance. Incredible power. Cutting-edge engineering.
Combined in just one vehicle: the Audi RS 7 Sportback.

The fuel consumption and CO₂ emission figures can be found
on page 56.





Unconditional driving pleasure. With Audi cylinder on demand.

■ The 4.0 litre V8 TFSI engine generates 412 kW and delivers a maximum torque of 700 Nm. Pure power that the quattro permanent all-wheel drive transfers to the road with confidence. The sprint from 0 to 100 km/h is effortless and takes just 3.9 seconds. The RS 7 Sportback also knows how to impress when it comes to efficiency, with Audi cylinder on demand shutting down four of the eight cylinders in the partial-load range. The engine continues to run smoothly and powerfully regardless. The difference is that fuel consumption and emissions are reduced.

The fuel consumption and CO₂ emission figures can be found on page 56.



■ Less weight equals more driving pleasure. The intelligent Audi lightweight technology improves the power-to-weight ratio and sharpens the handling dynamics. You are also assured of superb roadholding thanks to the standard RS adaptive air suspension. There is also the option of the RS sport suspension plus with Dynamic Ride Control (DRC) for a further reduction in the vehicle's pitching and rolling movements.

The fuel consumption and CO₂ emission figures can be found on page 56.



Unconditional athleticism. With elegance.

■ Elegance at its most powerful: the trademark Audi Singleframe featuring a matt aluminium-look frame and gloss black honeycomb grid creates an impression of outstanding strength. RS bumpers with large side air inlets and integrated flaps as well as the optional innovative Audi Matrix LED headlights with dark-tinted surrounds help to underline the individual character of the Audi RS 7 Sportback. The tornado line sets the tone for the side view's dynamic appearance, which is further emphasised by the distinctive widened sills. The trim strips and exterior mirror housings in matt aluminium look add some RS-specific touches.

The fuel consumption and CO₂ emission figures can be found on page 56.





Unmistakeably RS: the sporting traits of the Audi RS 7 Sportback. The optionally available 21-inch cast aluminium wheels in 5-spoke blade design provide a clear view of the optional ceramic brake behind. The RS bumper with gloss black diffuser insert and integrated oval tailpipe trims brings the vehicle's dynamically styled rear to an impressive conclusion.

The fuel consumption and CO₂ emission figures can be found on page 56.





- Keeping a firm grip on power: the shift paddles on the flat-bottomed RS multifunction sport leather steering wheel enable you to change gear manually without having to let go of its rim's chunky contours. Meanwhile, the MMI® navigation plus with MMI touch gives you perfectly intuitive control over many vehicle functions. Meaning that you can enjoy the extraordinary driving experience even more intensely.

The fuel consumption and CO₂ emission figures can be found on page 56.



▀ The interior exudes sportiness, exclusiveness and quality the moment you open the door. Details such as the illuminated door sill trims, stainless steel pedals, door openers with a delicate double-bar design and carbon inlays all serve to underline the vehicle's premium character. The RS sport seats with their boldly contoured form offer excellent lateral support even on the most challenging drives. Optional seat upholstery in Valcona leather with honeycomb-patterned stitching in rock grey adds to the sporty, exclusive ambience.

The fuel consumption and CO₂ emission figures can be found on page 56.





Not only does the Audi RS 7 Sportback feature unique dynamism, the way in which it adapts to the driver is just as individual. Thanks to the 8-speed tiptronic's Dynamic Shift Program (DSP), the transmission can automatically adjust to your driving style. Fast, precise gear changes at exactly the right moment help you to drive just the way you like. What's more, the transmission's wide ratio spread serves to increase efficiency, too.

With Audi drive select you can also modify the vehicle's character at any time at the push of a button. From the engine to the suspension, a range of components and systems can be configured for an even sportier or a more balanced ride.

The fuel consumption and CO₂ emission figures can be found on page 56.

■ Exclusive design. Unconditional dynamism. Experience all the fascination of an exceptional high-performance car – the Audi RS 7 Sportback.

The fuel consumption and CO₂ emission figures can be found on page 56.



Vorsprung durch Technik.

The world is constantly changing. Technology is advancing at an ever faster pace. And in the process, more and more opportunities are opening up to you – nowhere more so than in the field of mobility. We are playing an instrumental role in shaping this progress with Vorsprung durch Technik. Striving to provide you with technology that enriches your life. Making sure that we don't just satisfy your expectations of mobility both today and in the future, but continue to surpass them.



Audi Sport: Technologies from motor racing. Transferred to the road.

Thrilling performance. Whether it's works motorsport, customer racing or our high-performance models – you'll not get such a potent adrenalin rush anywhere else. Audi Sport utilises the expertise gained in motor racing to bring innovative technologies to series production. With unrivalled passion – for outstanding dynamism.





Consistent power. Put to consistent use. The TFSI® engine.

Powerhouse: the 4.0 litre V8 TFSI engine with 412 kW. With a maximum torque of 700 Nm the Audi RS 7 Sportback accelerates from 0 to 100 km/h in just 3.9 seconds. The propulsive power ends at an electronically regulated 250 km/h, with the option of boosting the top speed to 280 km/h or 305 km/h.

Efficiency system: with Audi cylinder on demand only four of the eight cylinders are active in partial-load operation depending on the driving conditions. The Audi valvelift system closes the intake and exhaust valves on two cylinders on each side and switches off their injection and ignition – whilst the engine continues to run as quietly as ever. As a result, neither is air drawn in nor fuel consumed – the fuel consumption and emission figures are noticeably improved. The 4.0 litre V8 TFSI engine also features a start-stop system and recuperation. And also excels with its spontaneous responsiveness and extraordinary power delivery over the entire engine speed range.

Control centre: the 8-speed tiptronic constitutes an adequate automatic transmission which is characterised by rapid gear changes and high efficiency. Thanks to the Dynamic Shift Program (DSP) gear-changing takes place in the optimum engine speed range – reducing power flow losses while you enjoy agile motoring. The tiptronic comes with a sport program (S) or manual mode for an even more dynamic driving style.

The fuel consumption and CO₂ emission figures can be found on page 56.

Superlative roadholding.

quattro® permanent all-wheel drive.

Outstanding traction, improved handling dynamics and more driving safety. Or quattro for short. Hardly any other drive system around transfers the engine's power to the road so effortlessly. The central component is the self-locking centre differential. The basic configuration of the purely mechanical planetary gear set distributes the drive torque asymmetrically for better driving dynamics. In a ratio of 40:60 between the front and rear axle. But if necessary up to 70% can be distributed to the front or up to 85% to the rear to offset any occurring wheel slip. Using wheel-selective torque control, the drive force is distributed to each individual wheel depending on the driving situation. What is special here is the way the effects of the torque distribution are felt before any undesirable wheel slip occurs. The result is a yawing moment which supports cornering – and thus provides precisely controlled, sporty handling with increased agility while maintaining superb traction.

By request the quattro drivetrain can be fitted with the sport differential on the rear axle, in order to further enhance driving dynamics.





Bending the road to your will.

RS suspension and RS brake systems.

RS brake systems

Demonstrate power. With the standard 19-inch RS brake system in the Audi RS 7 Sportback. The 6-piston fixed callipers at the front take powerful hold of the wave brake discs whose cast friction ring with a wave-shaped outer contour is connected to the aluminium brake disc chamber by means of steel pins. This so-called floating mounting ensures that the friction ring remains largely tension-free, thus improving stability when subjected to high temperatures. Axial perforation and cooling channels for internal ventilation increase the performance of the brake discs. The intelligent mix of materials and the characteristic geometry of the friction rings help reduce weight, thus improving the balance of the unsprung masses.

The optional 20-inch ceramic brake system* is available for even tougher requirements. It features brake discs made out of a carbon-fibre reinforced ceramic material which is based on hard silicon carbide with embedded high-strength carbon fibres. The result is enormous abrasion resistance, a long service life, reduced weight and higher fading resistance.

RS suspensions

Show character. Self-assured, sporty. With the RS adaptive air suspension. Experience outstanding directional stability and excellent agility coupled with precise steering characteristics. Thanks to the 5-link front axle design. Coupled with the self-tracking trapezoidal link principle of the rear axle. Many chassis components are made of aluminium to reduce weight and keep the unsprung masses low. The RS adaptive air suspension combines air suspension with a variably adaptive damper system. It allows for various ride heights and simultaneously acts as a level regulator so that driving features are not compromised even with a heavy load. The upshot is dynamic handling.

The RS sport suspension plus with Dynamic Ride Control (DRC) is available as an option. Steel springs and shock absorbers with variable characteristics reduce the pitching and rolling movements around the lateral and longitudinal axes by purely hydraulic means. The diagonal dampers are connected to one another via oil pipes and one central valve each. If the dampers compress differently, for example during fast cornering, the valves regulate the oil flow to the deflected wheel. They increase support there, thus reducing side tilt and enhancing driving dynamics.

The electromechanical power steering with RS-specific characteristic curve provides additional dynamism. Thanks to the low-position configuration, the steering forces are conducted just a short distance to the wheels, which provides a spontaneous steering response, precise feedback from the road and even more fun on bends. The steering also requires almost no energy when driving in a straight line, thus helping to reduce fuel consumption.

*Please consult your Audi partner or national Audi website to find out more about the special features of the ceramic brake. The fuel consumption and CO₂ emission figures can be found on page 56.

Reach your destination. The way you want.

Audi drive select.

Change character. With the standard Audi drive select in the Audi RS 7 Sportback. Individual vehicle components can be influenced at the push of a button – such as the engine characteristics, exhaust flap control, transmission mode, the damper regulation of the RS adaptive air suspension and the steering torque of the electromechanical power steering – to adapt them to the prevailing driving situation. With four different modes including various settings: auto, comfort, dynamic and individual. auto for superior sporty quality. comfort for longer journeys. dynamic for more ambitious driving. And individual, so you configure the individual components yourself according to your preferences.

In addition, various optional systems can be adjusted. For example, the characteristic curves of the shock absorbers on the RS sport suspension plus with Dynamic Ride Control (DRC) can be varied in three levels: from balanced rolling in comfort mode through to sporty, direct responsiveness in the dynamic setting. The optional dynamic steering can also be varied. The power steering assistance and ratio are changed depending on the road speed and the Audi drive select mode chosen. The optional quattro with sport differential also allows additional infinitely variable distribution of the drive forces between the rear wheels. This torque manipulation specifically influences the vehicle's steering behaviour and increases agility even further. The adaptive cruise control response can also be set to be either more gradual or more spontaneous.

The fuel consumption and CO₂ emission figures can be found on page 56.



A close-up photograph of the Audi RS 7 badge on a car's body panel. The badge is set against a dark, metallic background. It features the Audi logo (four interlocking rings) on the left, followed by the letters 'RS' in a stylized font where the 'R' is red and the 'S' is white with a black outline. To the right of 'RS' is a white '7' with a black outline. The car's body panel has a horizontal groove below the badge.

RS 7

As unique as you are.
The equipment options.

Sportiness, comfort, design, functionality – whatever you demand of your Audi, it offers you a wealth of custom options. Audi equipment versions are varied and high-quality and you can tailor them entirely to your needs.

Character takes on many forms. Here are two of them.

What makes an Audi your Audi? Vehicle equipment entirely tailored to your needs. There are a wide range of options available to you for giving your vehicle the exact touch you have in mind. More sportiness? More elegance? Let yourself be inspired.

Audi RS 7 Sportback in panther black, crystal effect

Cast aluminium wheels in 5-spoke blade design
in matt titanium look, gloss turned finish*

Matt aluminium styling package including air inlet duct
with quattro logo

RS sport seats, front, in Valcona leather, lunar silver
with honeycomb pattern in rock grey

RS multifunction sport leather steering wheel
in 3-spoke design

Inlays in aluminium/Beaufort wood, black



Audi RS 7 Sportback in Misano red, pearl effect

Cast aluminium wheels in 5-spoke blade design
in gloss black, gloss turned finish*

Carbon styling package including air inlet duct with
quattro logo

RS sport seats, front, with design package in Valcona
leather, black, with honeycomb pattern in Audi exclusive
crimson red

Extended leather package in black with contrasting
stitching in Audi exclusive crimson red

Carbon inlays



The fuel consumption and CO₂ emission figures can be found on page 56.

*Please note the special information relating to wheels on page 56.

Your Audi is painted not just once. But several times.

Choose the paint finish to suit your individual taste. But whichever colour you opt for, you can count on the outstanding quality of our painting process. Though no thicker than a human hair, the layer of paint on an Audi is actually made up of four different coats. And with a matt effect paint finish as many as six. To ensure that your Audi is optimally protected from environmental influences and wear. And also outwardly reflects your personality.



| Solid paint finish

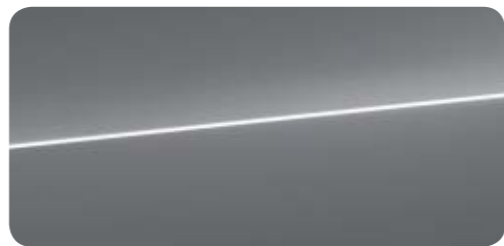

Nardo grey

| Metallic paint finishes



Glacier white, metallic

| Pearl effect paint finishes

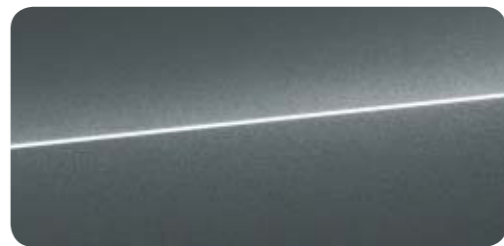

Daytona grey, pearl effect

| Crystal effect paint finishes



Prisma silver, crystal effect

| Matt effect paint finishes



Daytona grey, matt effect



Floret silver, metallic



Misano red, pearl effect

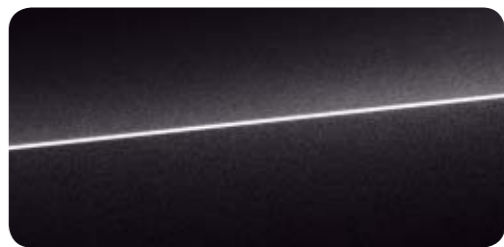

Panther black, crystal effect



Audi exclusive Sepang blue, matt effect
Audi exclusive Nardo grey, matt effect
Audi exclusive glacier white, matt effect
Audi exclusive floret silver, matt effect



Mythos black, metallic



Sepang blue, pearl effect



Audi exclusive customised paint finishes



The perfect connection between an Audi and the road: Audi wheels.

To make sure you have peace of mind for every metre of your drive, Audi puts its wheels through an exacting series of specialised test procedures. Hardness tests, for example, aim for maximum stability, while a copper accelerated salt spray test – CASS for short – using acetic acid guarantees the greatest possible corrosion protection. Thanks to these and many other measures, we can ensure that every Audi wheel offers maximum quality – even after scores of kilometres. No matter which of the numerous designs you choose.

| Summer wheels



Forged aluminium wheels
in 7-twin-spoke design, gloss turned finish¹
size 9 J x 20 with 275/35 R 20 tyres²



Cast aluminium wheels
in 5-spoke blade design in matt titanium look,
gloss turned finish¹
size 9 J x 21 with 275/30 R 21 tyres²

| Winter wheels



Cast aluminium winter wheels
in 7-twin-spoke design
size 8 J x 20 with 245/40 R 20 winter tyres²,
can be fitted with snow chains,
permissible top speed 240 km/h



Cast aluminium wheels
in 5-spoke blade design
size 9 J x 21 with 275/30 R 21 tyres²



Cast aluminium wheels
in 5-spoke blade design in gloss black,
gloss turned finish¹
size 9 J x 21 with 275/30 R 21 tyres²



Cast aluminium winter wheels
in 5-spoke blade design
size 9 J x 21 with 275/30 R 21 tyres²,
cannot be fitted with snow chains,
permissible top speed 270 km/h

Tyre pressure monitoring system
monitors the air pressure set in the tyres and the tyre temperature throughout the journey, also works with winter wheels delivered by Audi. Air pressures and temperatures of the individual tyres can be displayed in the MMI system.

¹The model-specific standard and optional equipment can be found in the index from page 58 onwards.

²Please note the special information relating to wheels on page 56. ²You will find specifications on the technical characteristics of tyres on page 63.

Premium quality you can rely on.

You have a special place in your Audi. Exclusivity can be felt on the front and rear seats: thanks to high-quality materials and first-class workmanship. No matter which seat upholstery you decide on and whether you prefer the RS sport seats with stable lateral support for dynamic driving or the customised contour seats: you're sitting in the right place.



RS sport seats, front ¹

The image shows RS sport seat, front, electrically adjustable¹, in Valcona leather, black, with honeycomb pattern in rock grey.



Customised contour seats, front ²

including memory function for driver and front-passenger seat, electric steering wheel adjustment and exterior mirrors. The illustration shows a customised contour seat with seat ventilation, front, in perforated Valcona leather, black.

| Leather



Alcantara/leather, black, with diamond pattern in black



¹ Valcona leather, black, with honeycomb pattern in black

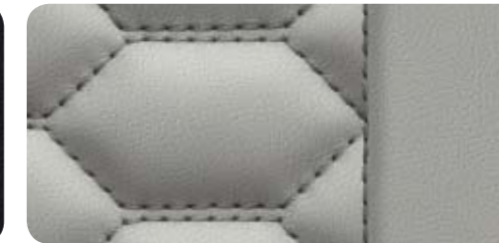

¹ Valcona leather, lunar silver, with honeycomb pattern in rock grey



¹ Audi exclusive leather upholstery and trim ¹ ²
individual choice of colour for leather/stitching/piping



Valcona leather, black



² Valcona leather, black with honeycomb pattern in rock grey ¹

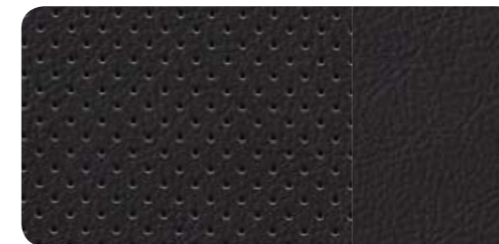

Valcona leather, black perforated²

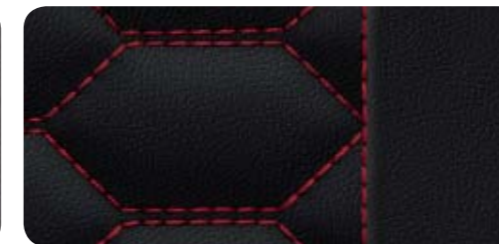

² Valcona leather, black with honeycomb pattern in Audi exclusive crimson red ¹

| Seat variants

- ¹ RS sport seats, front
- ² Customised contour seats, front

| Leather upholstery and trim

Alcantara/leather combination

for RS sport seats, front: seat centre panels and door trim inserts in Alcantara, as well as seat side bolsters, head restraints, centre armrest, front, and lower part of centre console in leather; seat centre panels on the front and rear seats with diamond pattern; RS 7 embossing on the front-seat backrests

Valcona leather upholstery and trim with honeycomb pattern

for RS sport seats, front: seat upholstery, head restraints and centre armrest, front, in Valcona leather; door trim inserts in Alcantara; lower part of centre console in leather; seat centre panels on the front and rear seats with honeycomb pattern; RS 7 embossing on the front-seat backrests

Valcona leather upholstery and trim

for customised contour seats, front: seat upholstery, head restraints and centre armrest, front, in Valcona leather; door trim inserts in Alcantara; lower part of centre console in leather; in conjunction with seat ventilation, front, seat centre panels on the front and rear seats perforated

Audi exclusive leather upholstery and trim (package 1) in Valcona leather

for customised contour seats, front: seat upholstery, head restraints, door trim inserts and centre armrest, front, in Valcona leather; lower part of centre console in leather. Individual choice of colour for the leather and the stitching from the range of Audi exclusive colours

Audi exclusive leather upholstery and trim (package 2) in Valcona leather

for customised contour seats, front, in addition to package 1: armrests in the door trims and seat backrest covers in leather; seat attachments matched to the leather colour. Individual choice of colour for the leather and the stitching from the range of Audi exclusive colours

Audi exclusive piping for customised contour seats

Individual choice of colour for the piping from the range of Audi exclusive colours. Only available in conjunction with Audi exclusive leather upholstery and trim (package 1 or 2) in Valcona leather

Audi exclusive leather upholstery and trim (package 1) in Alcantara/Valcona leather

for RS sport seats, front: seat centre panels and door trim inserts in Alcantara as well as seat side bolsters, head restraints and centre armrest, front, in Valcona leather; lower part of centre console in leather; seat centre panels on the front and rear seats with diamond pattern; RS 7 embossing on the front-seat backrests. Individual choice of colour for the Alcantara, the leather and the stitching from the range of Audi exclusive colours

Audi exclusive leather upholstery and trim (package 1) in Valcona leather with honeycomb pattern

for RS sport seats, front: seat upholstery, head restraints, door trim inserts and centre armrest, front, in Valcona leather; lower part of centre console in leather; seat centre panels on the front and rear seats with honeycomb pattern; RS 7 embossing on the front-seat backrests. Individual choice of colour for the leather and the stitching from the range of Audi exclusive colours

Audi exclusive leather upholstery and trim (package 2) in Valcona leather with honeycomb pattern

for RS sport seats, front, in addition to package 1: armrests in the door trims and seat backrest covers in leather; seat attachments matched to the leather colour. Individual choice of colour for the leather and the stitching from the range of Audi exclusive colours

Audi exclusive design package in Valcona leather with honeycomb pattern

for RS sport seats, front: seat upholstery, head restraints, door trim inserts and centre armrest, front, in Valcona leather, black, with crimson red contrasting stitching; armrests in the door trims and lower part of centre console in black leather with crimson red contrasting stitching; seat centre panels on the front and rear seats with honeycomb pattern in crimson red; RS 7 embossing on the front-seat backrests; including floor mats in black with leather piping in crimson red, controls with crimson red contrasting stitching and seat belts in crimson red

| Leather packages

Leather-covered armrests in the door trims

with Valcona leather upholstery and trim with honeycomb pattern in rock grey with contrasting stitching in rock grey

Leather-covered steering wheel airbag cover

for RS multifunction sport leather steering wheel and RS multifunction sport leather steering wheel, heated: in black leather

Audi exclusive leather package including airbag cover

armrests in the door trims, lower part of centre console and airbag cover in the steering wheel in leather. Individual choice of colours for the leather and the stitching from the range of Audi exclusive colours. In conjunction with RS multifunction sport leather steering wheel, flattened at the bottom, without leather-covered airbag cover

Audi exclusive extended leather package

dashboard underside including glove compartment, armrests in the door trims, centre console as well as lower part of centre console in leather. Individual choice of colour for the leather and the stitching from the range of Audi exclusive colours. Airbag cover on the steering wheel in black leather; in conjunction with RS multifunction sport leather steering wheel flattened at the bottom, without leather-covered airbag cover

Audi exclusive leather-covered seat trim

for customised contour seats, front, with memory function and RS sport seats, front, electrically adjustable: seat side trim and front trim (customised contour seats, front) or trim of the extendable thigh support (RS sport seats, front) in fine Nappa leather; seat side trim with stitching; switches and handles for seat adjustment in black (not leather-covered). Individual choice of colour for the leather and the stitching from the range of Audi exclusive colours

| Seating comfort

Front seats, electrically adjustable, including memory function for the driver seat

with electric adjustment of seat height, fore/aft position, seat and backrest angle as well as electric 4-way lumbar support; 2 presets for the electrically adjustable driver seat, the electric steering wheel adjustment and the exterior mirrors

Seat heating, front

heats the seat and backrest centre panels as well as the seat side bolsters; individually adjustable in several stages for driver and front-passenger side

Seat heating, front and rear

functions as for seat heating, front, additionally for the rear seats, can be adjusted separately in several stages

Seat ventilation, front

by drawing in air, the system ensures a pleasant seating climate can be enjoyed even in high temperatures; seat ventilation of the seat and backrest centre panels as well as the thigh support for the driver and front-passenger seats (adjustable in 3 stages); automatic seat heating to prevent cold seats. If seat ventilation, front, is fitted, the leather on the front and rear seats is perforated

Massage function, front

massages the muscles of driver and front passenger using 10 pneumatic cushions; 5 different programs (Wave, Tapping, Stretch, Back, Shoulder) and 5 levels of intensity via multifunction switches on the seat and via MMI; display in MMI

| Rear seats

RS sport seats in the rear

2 individual seats in the rear with shaped seat side bolsters and integrated head restraints, visually matched to the front seats; rear seat backrest can be split-folded 40:60 or fully; with remote backrest release in luggage compartment; rear seat bench with integrated storage compartment in the centre

RS sport seats in the rear including fold-out centre armrest

equipment as for RS sport seats in the rear, additionally with fold-out centre armrest with storage compartment and 2 cup holders

Rear seat system with 2 seats

visually matched to the front seats; 2 L-shaped rear head restraints, height manually adjustable, rear seat backrest can be split-folded 40:60 or fully; including fold-out centre armrest with storage compartment and 2 cup holders

| Headlinings

Headlining in cloth

in black or lunar silver, depending on the interior colour selected

Headlining in Alcantara, black

headlining, upper pillar trim, rear parcel shelf and sun visors in Alcantara, black, stitching in black

Audi exclusive headlining in Alcantara, black, with coloured stitching

headlining, upper pillar trim, rear parcel shelf and sun visors in Alcantara, black. Individual choice of colour for the stitching from the range of Audi exclusive colours

Experience fascination. Down to the last detail.

The exclusive Audi inlays emphasise the sporty ambience of your vehicle. At first sight. Be inspired by refined carbon, aluminium, piano finish or wood for the dashboard with all-round inlay, centre console and door trims. High quality and precise workmanship harmoniously integrated in the interior.



The model-specific standard and optional equipment can be found in the index from page 58 onwards.

| Inlays



Carbon

surrounds for the all-round inlay, door trims and centre console in aluminium look



Aluminium race

Inlays

full-surface for the dashboard, door trims, centre console, and all-round inlay

Audi exclusive wood inlays

available in fine grain ash, nougat; oak sepia; fine grain myrtle, nutmeg; vavona bronze; modrone, gold; tamo ash, natural dark brown



Piano finish, black

surrounds for the all-round inlay, door trims and centre console in aluminium look



Matt brushed aluminium



Aluminium/Beaufort wood, black

surrounds for the all-round inlay, door trims and centre console in aluminium look



Audi exclusive wood inlays

surrounds for the all-round inlay, door trims and centre console in aluminium look

| Equipment packages

Comfort package

- includes:
 - Bose Surround Sound
 - seat heating, front and rear
 - interior mirror, automatically dimming
 - exterior mirrors, electrically adjustable, heated and folding, automatically dimming on both sides, with memory function
 - 75 l fuel tank

Dynamic package

- includes:
 - dynamic steering
 - quattro with sport differential
 - RS sport suspension plus with Dynamic Ride Control (DRC)
 - top speed increased to 280 km/h
 - Audi Matrix LED headlights
 - interior mirror, automatically dimming

Dynamic package plus

- includes:
 - ceramic brake
 - dynamic steering
 - quattro with sport differential
 - RS sport suspension plus with Dynamic Ride Control (DRC)
 - top speed increased to 305 km/h
 - Audi Matrix LED headlights
 - interior mirror, automatically dimming

| Headlights/interior light

LED headlights

allow precise, near-daylight illumination of the road; combine LED dipped beam, high beam, daytime running lights, motorway light, indicator and static turning light as well as an all-weather light; including headlight cleaning system; motorway light that automatically increases headlight range from a speed of approximately 110 km/h; all-weather light to reduce the risk of the driver being dazzled when visibility is poor; striking light pattern in day and night design configurations; low energy consumption and long service life

Audi Matrix LED headlights

The innovative technology combines a camera system with LED light sources and precision optics for highly adaptive light distribution. The system blanks out light that would otherwise shine directly on oncoming vehicles or vehicles in front but continues to fully illuminate all the other areas in between and alongside. The front lighting thus adapts dynamically, providing the driver with a much wider visual range. The conventional division between dipped and high beam is dispensed with. Familiar convenience functions such as the static turning light, all-weather light, junction light, motorway light and travel mode, which uses GPS data to switch between right- and left-hand drive modes, are integrated into the LED technology. The LEDs of the Audi Matrix LED headlights also perform the dynamic cornering light functions. Using vehicle support based on navigation data, it starts responding shortly before the steering wheel is turned. The marking light cooperates with the optional night vision assistant. If pedestrians are detected, individual LEDs flash briefly three times in succession to mark out the pedestrians clearly from their surroundings. Distinctive features include the crisp lighting pattern, the LED daytime running lights and the dynamic indicators in the headlights and rear lights as well as the dark-tinted surrounds at the front. Including headlight cleaning system

LED rear lights with dynamic indicators

brake lights, tail lights, rear fog lights, indicators, reversing lights and rear number plate lights in low-energy LED technology; with third, high-mounted brake light in the rear window; with dynamic, clearly visible actuation of the indicators: segments of the LED light band are triggered for a few milliseconds, creating a pulse of light that runs outwards in the direction the car is turning. When operated, the indicators send a distinctive signal to other road users

High-beam assist

improves the driver’s visibility and ensures a more relaxed drive thanks to the extra comfort and convenience. Depending on the traffic situation, the high beam is automatically switched on or off. Working within system limits, automatically detects the headlights of oncoming traffic, the rear lights of other road users and light sources in built-up areas. In conjunction with the optional night vision assistant, the networked vehicle functions provide the marking light for detected pedestrian for enhanced safety when driving at night.

Ambient lighting

including integrated eyewear compartment in the roof module; ambient lighting can be configured via the MMI

- with delayed switch-off and contact switches on all doors
- glove compartment lighting
- luggage compartment lighting
- active door reflectors

in LED technology:

- courtesy lighting on the underside of the door handles and handle recess lighting
- entrance lighting, front and rear
- 2 reading lights each at front and rear
- lighting for door pockets, interior door handles, vanity mirrors and footwell
- ambient lighting for centre console and door inner panels to help occupants better orient themselves

| Exterior design

Model name/logo

RS 7 logo in the Audi Singleframe and on the luggage compartment lid

Audi Singleframe

with radiator grille with honeycomb design in gloss black and one-piece trim frame in matt aluminium look

RS bumpers

in sporty dynamic design; at the front with large air inlets and side flaps in gloss black, as well as front spoiler in matt aluminium look, at the rear with diffuser insert in gloss black

Sill extensions

painted in body colour

Trim strips

on the side windows in matt aluminium look, outside of B-pillar trim in gloss black

Engine cover with carbon trim

side inserts of design engine cover in carbon

Rear spoiler

integrated in the luggage compartment lid; automatically extends at 130 km/h, retracts at 80 km/h; can also be controlled manually via a button on the centre console

| Wheels

Matt aluminium styling package including air inlet duct with quattro® logo

side flaps and top edge of the rear diffuser insert in matt aluminium look; including air inlet duct in the Audi Singleframe in matt aluminium look with quattro logo in titanium grey, matt

Gloss black styling package including air inlet duct with quattro® logo

front spoiler, frame of the radiator grille and trim strips on the side windows in gloss black; including air inlet duct in the Audi Singleframe in gloss black with quattro logo in titanium grey, matt

Carbon styling package including air inlet duct with quattro® logo

front spoiler, side flaps and rear diffuser insert in carbon; including air inlet duct in the Audi Singleframe in carbon with quattro logo in titanium grey, matt; frame on the radiator grille and trim strips on the side windows in gloss black

Wheels

19" alloy wheels in gloss black, optional 20" alloy wheels in gloss black

Wheels with RS 7 logo

19" alloy wheels in gloss black, optional 20" alloy wheels in gloss black

Wheels with RS 7 logo

Wheels with RS 7 logo

Wheels with RS 7 logo

Wheels with RS 7 logo

Wheels with RS 7 logo

Wheels with RS 7 logo

Wheels with RS 7 logo

Wheels with RS 7 logo

Wheels with RS 7 logo

Wheels with RS 7 logo

Wheels with RS 7 logo

Wheels with RS 7 logo

Wheels with RS 7 logo

Wheels with RS 7 logo

Wheels with RS 7 logo

Wheels with RS 7 logo

| Equipment packages

Comfort package

- includes:
 - Bose Surround Sound
 - seat heating, front and rear
 - interior mirror, automatically dimming
 - exterior mirrors, electrically adjustable, heated and folding, automatically dimming on both sides, with memory function
 - 75 l fuel tank

Dynamic package

- includes:
 - dynamic steering
 - quattro with sport differential
 - RS sport suspension plus with Dynamic Ride Control (DRC)
 - top speed increased to 280 km/h
 - Audi Matrix LED headlights
 - interior mirror, automatically dimming

Dynamic package plus

- includes:
 - ceramic brake
 - dynamic steering
 - quattro with sport differential
 - RS sport suspension plus with Dynamic Ride Control (DRC)
 - top speed increased to 305 km/h
 - Audi Matrix LED headlights
 - interior mirror, automatically dimming

Dynamic package plus

- includes:
 - ceramic brake
 - dynamic steering
 - quattro with sport differential
 - RS sport suspension plus with Dynamic Ride Control (DRC)
 - top speed increased to 305 km/h
 - Audi Matrix LED headlights
 - interior mirror, automatically dimming

Dynamic package plus

includes:

- ceramic brake
- dynamic steering
- quattro with sport differential
- RS sport suspension plus with Dynamic Ride Control (DRC)
- top speed increased to 305 km/h
- Audi Matrix LED headlights
- interior mirror, automatically dimming

Dynamic package plus

Dynamic package plus

Dynamic package plus

Dynamic package plus

Dynamic package plus

Dynamic package plus

Dynamic package plus

Dynamic package plus

Dynamic package plus

Dynamic package plus

Dynamic package plus

Dynamic package plus

Dynamic package plus

Dynamic package plus

Dynamic package plus

Dynamic package plus

Dynamic package plus

| Technology

Steering wheels/controls

RS multifunction sport leather steering wheel in 3-spoke design, flattened at the bottom adjustable in height and reach; with shift paddles in aluminium look, RS 7 emblem and full-size airbag; flat-bottomed steering wheel rim upholstered in perforated leather and contrasting stitching in rock grey; for operating the available infotainment features

RS multifunction sport leather steering wheel in 3-spoke design

adjustable in height and reach; with shift paddles in aluminium look, RS 7 emblem and full-size airbag; upholstered in perforated leather with contrasting stitching in rock grey; for operating the available infotainment features

RS multifunction sport leather steering wheel in 3-spoke design, heated

features as for RS multifunction sport leather steering wheel in 3-spoke design; additionally heated steering wheel rim

Electric steering wheel adjustment

adjustable in height and reach, with automatic entry and exit function

RS selector lever knob in perforated leather

with RS logo and decorative ring in aluminium look; selector lever gaiter in leather with contrasting stitching in rock grey

RS selector lever knob in leather

RS selector lever knob in leather

RS selector lever knob in leather

RS selector lever knob in leather

RS selector lever knob in leather

RS selector lever knob in leather

RS selector lever knob in leather

RS selector lever knob in leather

RS selector lever knob in leather

RS selector lever knob in leather

RS selector lever knob in leather

RS selector lever knob in leather

RS selector lever knob in leather

RS selector lever knob in leather

RS selector lever knob in leather

RS selector lever knob in leather

Equipment

Equipment

Equipment

Equipment

Equipment

Equipment

Equipment

Equipment

Equipment

Equipment

Equipment

Equipment

Equipment

Equipment

Equipment

Equipment

Equipment

Equipment

Equipment

Equipment

Equipment

Equipment

Equipment

Equipment

Equipment

Equipment

Equipment

Equipment

Equipment

Equipment

Equipment

Equipment

Equipment

Equipment

Equipment

Equipment

Equipment

Equipment

Equipment

Equipment

Equipment

Equipment

Equipment

Equipment

The model-specific standard and optional equipment can be found in the index from page 58 onwards.

				Equipment packages	Lights	Design	Steering wheels/controls	Comfort	Infotainment	Assistance systems	Technology/safety	Audi Extended Warranty
 Mirrors	 Roof system	 Climate control	 Closing systems	 Storage/transport	 MMI®/navigation/display instruments							
Exterior mirrors with integrated LED indicator electrically adjustable and heated, convex, flat or aspherical mirror glass	Slide-and-tilt glass sunroof electric, with tinted single-glazed safety glass and infinitely adjustable sun screen; includes integrated wind deflector; convenience opening/closing from outside via the vehicle key	4-zone deluxe automatic air conditioning <ul style="list-style-type: none">with indirect ventilation and sunlight-dependent control electronically regulates the air temperature, flow rate and distribution humidity sensor combined fine particulate filter automatic recirculation mode by means of air quality sensor use of residual heat separate regulation of footwell temperature ventilated glove compartment front air-conditioning controls with digital display separate temperature control for driver and front-passenger sides ventilation in the rear via the centre console air vents in the B-pillars additional air-conditioning controls with digital display for climate control in the rear with separately adjustable temperature and blower control and air distribution for the right- and left-hand sides (rear functions can also be set from the front air conditioning control) choice of 3 climates: gentle, medium, intensive key-coded settings	Convenience key access authorisation system, the key only needs to be carried with you; the vehicle is locked and unlocked from outside via sensors on all door handles. The luggage compartment lid can also be opened separately when the vehicle is locked.	Power-assisted door closing automatically pulls doors that are not completely closed into the locks	RS instrument cluster with black dials, red needles, white scales, RS 7 logo in rev counter and dynamic ready-check feature							
also optionally:				Garage door opener (HomeLink) programmable radio-operated remote control with operating buttons integrated into the front roof module; can be used to open many garage doors and exterior gates; allows control of security and lighting systems; code identification guidance and set-up assistance provided by the MMI navigation plus. For further information please contact your Audi partner or visit www.eurohomelink.com.	Driver information system with colour display high-resolution 7-inch TFT colour display directly in the driver’s field of vision; displays information from the MMI system, the infotainment systems and the driver assistance systems; display for the onboard computer with short and long-term memory, digital speedometer, gear display, outside temperature, plus door and luggage compartment lid check; RS menu with shift light, charge pressure and oil temperature display as well as lap timer; can be operated via an RS multifunction sport leather steering wheel; including attention assist: attention assist warns the driver by way of an acoustic signal and a visual warning if it deems the driver’s attention is lapsing.							
with memory function including automatic kerb-side function for the exterior mirror on the passenger side				Anti-theft alarm monitors doors, bonnet and luggage compartment lid; includes interior monitoring (can be deactivated), tow-away protection via a vehicle angle of inclination sensor and signal horn independent of the vehicle electrical system; with safe-locking function: prevents the doors from being opened from the inside once the vehicle has been locked with the vehicle key	Storage package luggage compartment net for securing to the lashing points on the luggage compartment floor, additional 12V socket in the rear							
electrically folding, with memory function including automatic kerb-side function for the exterior mirror on the passenger side	 Glazing			Luggage compartment lid, electrically opening and closing opening via the button on the vehicle key or in the driver’s door or using the soft touch button in the luggage compartment lid handle recess; closing via button on inside of luggage compartment lid, the button in the driver’s door or via the optional convenience key (long press). In conjunction with the convenience key, it is possible to close the luggage compartment lid and simultaneously lock the car via an additional button on the inside of the luggage compartment lid. Including power-assisted closing and programmable luggage compartment lid opening angle	Luggage compartment large-volume, with large through-loading width; including side net and 12V socket on the right-hand side of the luggage compartment as well as bag hooks on the left and right and 4 lashing points on the floor of the luggage compartment; luggage compartment cover							
electrically folding and automatically dimming on both sides, with memory function including automatic kerb-side function for the exterior mirror on the passenger side	Heat-insulating glass green-tinted; windscreen and front side windows with acoustic glazing for improved noise insulation; rear window heated, with timer			Convenience key with sensor-controlled luggage compartment lid release features as for convenience key. Moving your foot (in a kicking motion) below the rear bumper causes the luggage compartment lid to swing open automatically when the vehicle key is recognised.	Through-loading facility for the practical transportation of long objects							
	Dark-tinted windows (privacy glazing) dark-tinted rear window as well as rear door windows and rear side windows				Preparation for tracking system preparation for connecting a tracking system (available from Audi Genuine Accessories) that enables a stolen vehicle to be located and tracked							
	Insulating/acoustic glass provides improved exterior noise insulation and theft protection thanks to the 2 panes of glass bonded together by a plastic film. An additional reflective coating reduces the build-up of heat in the interior. Windscreen with viewing window for toll collection devices; rear window in standard glass											
	Insulating/acoustic glass and dark-tinted windows (privacy glazing) windscreen and front door windows in insulating/acoustic glass; rear window, rear door and rear side windows in dark-tinted standard glass; windscreen with viewing window for toll collection devices											
	Sun screen in the luggage compartment cover, extendible, in black cloth											
Exterior mirror housings												
choice of:												
matt aluminium look												
painted in body colour												
gloss black												
carbon												

The model-specific standard and optional equipment can be found in the index from page 58 onwards.

^[1] The navigation data for supported countries is contained in the integrated memory. For more information, please contact your Audi partner.
^[2] The map version delivered can be updated with the first 5 updates which are issued at intervals of 6 months. The current navigation data can be downloaded from the myAudi platform at www.audi.com/myaudi and installed via SD card in the vehicle. In conjunction with Audi connect, the update can be carried out online in the vehicle. It is also possible to have the new navigation data installed by an Audi partner (at extra cost).
^[3] The Audi connect service traffic information online is available for several countries. For more information, please contact your Audi partner.
^[4] Provided the mobile phone has the Bluetooth profile MAP (Message Access Profile). Please contact your Audi partner or visit www.audi.com/bluetooth for information on compatible mobile phones.
^[5] Requires the optional equipment Audi connect.

Equipment packages Lights Design Steering wheels/controls Comfort Infotainment Assistance systems Technology/safety Audi Extended Warranty

| Entertainment

Digital Audio Broadcasting

in addition to the range of analogue stations, receives programmes from digitally broadcast radio stations¹ according to DAB standard, including DAB+ and DMB audio; display of information accompanying the programme (e.g. artist and track, if provided by the radio station) as well as additional information in the form of a slide show (e.g. cover and weather)

Digital TV reception

reception of digitally broadcast (DVB-T and DVB-T2) free-to-air television stations² (MPEG-2 or MPEG-4 standard) as well as DVB-T audio stations; display of information accompanying the programme such as teletext, subtitles and Electronic Programme Guide (EPG); automatic station search; external AV-IN connection via adapter cable; no picture possible when the vehicle is moving

Audi music interface

Portable media players² such as an Apple iPod/iPhone (music functionality) as well as USB storage media and MP3 players can be connected to the vehicle via a USB interface (including power supply/charge function) or Wi-Fi. Located in the centre console; operated via MMI or RS multifunction sport leather steering wheel; part of MMI navigation plus with MMI touch

DVD/CD changer

for 6 DVDs or CDs, supports e.g. audio CDs, video DVDs; shock-resistant location in the glove compartment and can be operated via MMI

Audi sound system

impressive sound thanks to 6-channel amplifier with a total output of 180 watts and 10 loudspeakers including centre speaker and subwoofer

Bose Surround Sound

impressive reproduction of 5.1 surround sound thanks to 12-channel amplifier with total output of 472 watts and 14 loudspeakers including centre speaker and subwoofer; AudioPilot® for noise-dependent volume adjustment and powerful and accurate bass reproduction, lifelike sound with natural tone and a feeling of space for an outstanding sound experience

Bang & Olufsen Advanced Sound System

exhilarating reproduction of 5.1 surround sound with 15 loudspeakers including centre speaker and subwoofer, each with its own amplifier channel. The efficient 15-channel DSP all-digital amplifier with integrated 5-channel ICE Power amplifier for woofers and subwoofer features a total output of over 1200 watts. Polished loudspeaker covers in aluminium and automatically extending acoustic lenses for excellent sound performance and perspective from every seat, with noise-dependent volume adjustment. Privacy function provided by encapsulated loudspeaker casings which minimise the escape of sound to the outside of the vehicle and provide privacy, for example when making telephone calls

Preparation for Rear Seat Entertainment

includes pre-installed wiring and mounts for the holders in the driver and front-passenger seat backrests. The appropriate Audi Entertainment mobile or Apple iPad adapter are available as a plug-and-play unit from Audi Genuine Accessories

| Communication

Audi connect

convenient connection of your vehicle to the internet for the use of Audi connect via an integrated data module with LTE³/UMTS support. There is a reader for your SIM card in the surround of the MMI navigation plus with MMI touch.

The following services supported by Audi connect are currently available in your model:

Mobility & navigation

- point-of-interest (POI) search with voice control
- traffic information online⁴
- picturebook navigation
- fuel prices
- parking information
- navigation with Google Earth™⁵ and Google Street View™⁵
- map update online⁶
- destination entry via myAudi or Google Maps™⁵

Communication

- Wi-Fi hotspot
- messages (text messages)^{7, 8}
- access to Facebook
- access to Twitter
- access to smartphone voice control

Infotainment

- weather
- online media streaming⁹
- news online (individual)
- travel information

In conjunction with the optionally available Audi phone box, Audi connect includes a car phone function via SIM card slot or rSAP profile.

Use of the services supported by Audi connect is only possible with the optional Audi connect feature. You also require a SIM card with data option and, if you wish to use LTE, also an LTE option³. The services are only available in conjunction with an existing or separate mobile phone contract and only within the range of the respective mobile phone network. Additional costs may be incurred when receiving data packets from the internet, depending on the terms of your mobile phone contract, particularly when used abroad. Because of the high data volumes involved, a data flat rate is strongly recommended.

The availability of the services supported by Audi connect varies from country to country. Audi connect services are provided for at least 1 year from vehicle delivery. After 24 months have expired, the Audi connect services will be extended free of charge once for 12 months. If you do not require this free extension, please notify us by writing to the following address:

AUDI International
Customer Care Services
85045 Ingolstadt,
Germany
Email: kundenbetreuung@audi.de
Tel.: +49 (0) 800-2834 7378423

The services city events, train and flight information, plus any other services, are available to the customer for a period of 12 months. Ask your Audi partner about a subsequent extension of the Audi connect services.

Depending on the vehicle model, Audi connect provides access to Facebook, Google and Twitter services.

Permanent availability cannot be guaranteed as this is the responsibility of Facebook, Google and Twitter.

Please visit www.audi.com/connect or contact your Audi partner for more detailed information about Audi connect; contact your mobile services provider for information about contract conditions.

Audi MMI® connect app

The Audi MMI connect app available for some smartphones® supports the following Audi connect services:

- Audi music stream
- point-of-interest (POI) search with voice control
- destination entry via myAudi or Google Maps™⁵
- traffic information online⁴

Bluetooth interface

allows hands-free calls to be made in the vehicle using the microphone and – depending on mobile phone compatibility⁸ – Bluetooth audio streaming. Bluetooth-capable mobile phones can be connected to the vehicle via the interface. Part of MMI navigation plus with MMI touch

Audi phone box⁸

allows phone calls with improved reception quality to be made in the vehicle by placing the mobile phone into the universal phone holder near the centre armrest, front; possible to connect 2 mobile phones¹⁰ via Bluetooth; hands-free facility and voice control (telephone); low SAR radiation in the interior thanks to connection to vehicle aerial; operated via MMI or the RS multifunction sport leather steering wheel; can be charged via USB port.

In conjunction with Audi connect, Audi phone box includes a car phone function via SIM card slot or rSAP profile.

| Assistance systems

Hold assist¹¹

holds the vehicle stationary for unlimited periods after stopping in traffic on normal uphill and downhill gradients. The system is activated by push-button and allows the driver to drive away smoothly.

Parking system plus¹¹

acoustic and visual parking system, front and rear, assists with parking and manoeuvring. Information shown in the MMI display; measurement by ultrasonic sensors concealed in the bumpers; activated when reverse gear is selected or via the button on the centre console

Park assist¹¹

uses ultrasonic sensors to search for suitable parking spaces along the side of the road and helps the driver to manoeuvre in and out of parking spaces by performing virtually autonomous steering actions. Calculates the ideal parking path for perpendicular parking spaces and the ideal parking and exiting paths for parallel parking spaces. The driver has to accelerate, apply the brakes and monitor the parking process. Activated via a button on the centre console

Reversing camera¹¹

image of area behind the vehicle shown on the MMI display, with dynamic display modes showing the path calculated based on steering angle; auxiliary lines and guidelines and identification of the point at which to apply opposite lock when parallel parking; reversing camera integrated discreetly in the handle strip of the luggage compartment lid; activated when reverse gear is selected or via a button on the centre console

Front and reversing cameras¹¹

image of area in front and behind the vehicle shown on the MMI display, for the reversing camera with dynamic display modes showing the calculated path depending on the steering angle; help lines and guidelines and identification of the point at which to apply opposite lock when parallel parking; reversing camera integrated discreetly in the handle strip of the luggage compartment lid; additional display modes for front left/right side and rear left/right side for safe pulling out of tight parking spaces, courtyard entrances or in car parks; activated when reverse gear is selected or via a button on the centre console

Audi pre sense basic¹¹

automatically initiates preventive occupant protection measures where necessary; these include: belt tightening, activating the hazard warning lights and closing the slide-and-tilt glass sunroof (if ordered) and windows; categorises driving situations by networking the different vehicle systems

Cruise control¹¹

At speeds of from around 30 to 250 km/h, the system keeps the set speed constant provided that engine power and engine braking effect permit it; operated via separate steering column stalk, set speed displayed in the driver information system

adaptive cruise control with Stop&Go function

including Audi pre sense front¹¹

detects vehicles ahead with the aid of radar sensors. The distance from the vehicle ahead is kept more or less constant by braking or accelerating (control range 0–250 km/h). 4 distance levels and 3 driving modes can be set (comfort, auto and dynamic). Including Audi pre sense front: enhanced brake assist warns of any imminent threat of collision with the vehicle in front. Can initiate partial braking action or boost the driver's braking action if necessary. In addition, maximum braking is initiated at speeds below 30 km/h if there is a danger of collision with a stationary or moving vehicle in order to reduce the speed of the collision or to avoid the collision if possible. Operation of adaptive cruise control via separate steering column stalk. Audi pre sense front can be deactivated via the MMI car menu.

Audi side assist including Audi pre sense rear¹¹

warns by means of an LED display on the relevant exterior mirror of any situations deemed critical for changing lanes. 2 radar sensors record the vehicle approaching at the side from behind and measure the distance and the difference in speed. The lane change assistant provides support in the speed range from around 30 to 250 km/h. In addition to the functions of Audi pre sense basic, Audi pre sense rear uses the rear sensors of Audi side assist to detect a possible rear-end collision. Activated via a button in the mirror quadrant

¹Reception depends on digital network availability. ²Please contact your Audi partner or visit www.audi.com/mp3 for information on compatible media players. ³Please contact your Audi partner regarding availability and use of LTE support. ⁴The traffic information online service from Audi connect is available for many countries. For more information, please contact your Audi partner. ⁵Google and the Google logo are registered trademarks of Google Inc.

⁶The map version supplied can be updated with the first 5 navigation updates which are issued at intervals of 6 months. The current navigation data is provided for downloading on the myAudi platform at www.audi.com/myaudi and can be installed via SD card in the vehicle. In conjunction with Audi connect, the update can be carried out online in the vehicle. It is also possible to have the new navigation data installed by an Audi partner (at extra cost).

⁷Provided the mobile phone has the Bluetooth profile MAP (Message Access Profile). ⁸Please contact your Audi partner or visit www.audi.com/bluetooth for information on compatible mobile phones. ⁹Depending on country-specific availability. To use this feature you will generally require an account with a media streaming provider. Additional costs may be incurred as a result. ¹⁰For information on when this feature will be available, please contact your Audi partner.

¹¹Please note: The systems work only within system limits and support the driver. However, the driver remains responsible for driving the vehicle and is required to be attentive.

Equipment packages Lights Design Steering wheels/controls Comfort Infotainment Assistance systems Technology/safety Audi Extended Warranty

| Assistance systems

Audi active lane assist¹

helps you to keep in lane by means of gentle, corrective steering intervention. The lane compliance assistant is triggered when the driver starts to cross detected lane markings without activating an indicator. The system provides support in the speed range from around 60 to 250 km/h. Steering wheel vibration can be set if the driver wants; additional display in the optional head-up display; activation via button on the steering column stalk for the indicator.

In conjunction with the optional Audi side assist including Audi pre sense rear, a perceptible steering movement is also made before leaving the lane, if changing lane is deemed particularly critical due to a vehicle approaching from behind. This steering movement is made even if the indicator has been activated but only if both systems are activated and ready.

Assistance package including Audi pre sense plus¹

combines the following assistance systems:

- adaptive cruise control with Stop&Go function
- Audi side assist
- Audi active lane assist
- Audi pre sense basic
- Audi pre sense front
- Audi pre sense rear

A maximum deceleration function provided by Audi pre sense plus is added to the aforementioned functions. The systems in the assistance package complement each other and provide mutual assistance. Details of how to activate or adjust assistance systems can be found in the relevant system description.

Night vision assistant¹

assists the driver when driving at night by displaying a thermal image of the surroundings. People and larger wild animals are highlighted in yellow on the colour display in the driver information system. If they move or if the system determines from their position that there is a potential risk, the marking changes to red, a warning triangle appears and a warning tone is emitted.

In conjunction with one of the following lighting systems, the marked person is also illuminated with 3 successive brief flashes of the headlights (marking light):

- LED headlights in combination with high-beam assist
- Audi Matrix LED headlights

Additional display of warnings in the optional head-up display; activation via button next to the light switch

Camera-based speed limit display^{1,2}

recognition and display of speed limits, including temporary speed limit displays; there is an evaluation of the particular situation in wet conditions, with speed limits displayed depending on the time of day; if a sign has not been recognised by the camera, thanks to Audi connect the speed limit taken from the current navigation data can be displayed; automatic display in the driver information system, additionally in the optional head-up display. The system simply provides information and does not intervene or provide a warning if the displayed speed is exceeded.

| Driving dynamics/brakes

Audi drive select

features different modes – comfort, auto, dynamic and individual – which allow you to change the vehicle’s characteristics by adapting the power steering assistance, engine characteristics, gear-change characteristics, RS adaptive air suspension, exhaust flap control and the settings of other optional equipment

RS adaptive air suspension

automatically controls vehicle level and damping by means of the electronically controlled air suspension with infinitely variable adaptive damping system on all 4 wheels; with RS 7-specific tuning; includes ride height control and manual lift function; various modes can be selected via Audi drive select

RS sport suspension plus with Dynamic Ride Control (DRC)

adjustable in 3 stages; single-tube gas-filled shock absorbers with variable damper characteristics and coil springs; control range of Dynamic Ride Control (DRC) can be selected in 3 stages via Audi drive select: comfort, auto, dynamic

quattro®

permanent all-wheel drive with self-locking centre differential and asymmetric/dynamic torque distribution, as well as wheel-selective torque control and Electronic Differential Lock (EDL); distributes the drive forces depending on the driving situation to each individual wheel for precisely controlled, sporty handling; quattro emblem in the dashboard on the passenger side

quattro® with sport differential

The electronically controlled sport differential distributes variable amounts of drive force to each rear wheel and ensures outstanding acceleration performance in corners and stabilises the vehicle’s response to load change. It also improves direct steering characteristics and provides more agile handling due to the lower steering effort required.

tiptronic

8-speed automatic transmission with Dynamic Shift Program (DSP) and sport program; option of manual control via shift paddles on the RS multifunction sport leather steering wheel or by nudging the selector lever

Electromechanical power steering

combines precision and comfort with exceptional energy-saving technology. The electromechanical steering system with speed-dependent power assistance ensures stability at high speeds whilst also being light and precise when parking and manoeuvring. With active countersteering to provide steering assistance to the driver for enhanced vehicle stability

Dynamic steering

when cornering, changing lanes or parking, for example, this system improves handling and ride comfort by dynamically regulating steering according to the driving situation; in addition to adaptation of the steering effort, the steering angle is also adapted (steering ratio); also supports vehicle stabilisation through ESC

RS brake system

19-inch diagonally-split high-performance brake system, Antilock Brake System (ABS) with Electronic Brake Force Distribution (EBD), Electronic Stabilisation Control (ESC) with brake assist, aluminium tandem brake booster, wave brake discs ventilated at front and rear, perforated and with floating mounting; brake callipers painted in gloss black with RS logo at front and rear

Brake callipers painted gloss red

for RS brake system, with RS logo front and rear

Ceramic brake³

20-inch high-performance brake system with carbon-fibre reinforced ceramic brake discs and brake callipers painted in gloss anthracite grey and featuring the “Audi ceramic” logo at front and rear; ventilated and perforated brake discs with special cooling channels

Top speed increased to 280 km/h

electronically regulated

| Technology/safety

Electronic Stabilisation Control (ESC)

with sport mode, can be deactivated in 2 stages; provides better stability at any speed through targeted braking of individual wheels and intervention in the engine management system; networks the ABS, EBD, ASR and EDL with its own sensors and compares the driving data with reference data

RS exhaust system

dual-branch design with chrome-plated oval tailpipe trims

RS sport exhaust system

for an enhanced acoustic experience; dual-branch, with gloss black oval tailpipe trims

Recuperation

economises on fuel through brake energy recovery; kinetic energy is converted into usable electrical energy by increasing the generator voltage when the vehicle is coasting or braking and relieving the generator during subsequent acceleration

Start-stop system

helps to reduce fuel consumption and CO₂ emissions by automatically switching off the engine when the vehicle is stationary, e.g. at traffic lights. The start process is initiated as soon as the foot brake is released. Can be deactivated at any time via a button

Side airbags, rear

to supplement side airbags, front, and head airbag system

Audi exclusive seat belts

individual choice of colour for seat belt from the Audi exclusive colour range

ISOFIX child seat mounting and top tether for the rear seats

standard mounting for practical attachment of ISOFIX child seats; includes additional fastening point (top tether).

Recommended child seats can be obtained from your Audi partner.

ISOFIX child seat mounting for the front-passenger seat

with passenger airbag deactivation switch, includes separate electric child-proof lock on rear doors

| Audi Extended Warranty

Audi Extended Warranty

The Audi Extended Warranty provides extended risk cover and cost control beyond the first 2 years of the manufacturer’s warranty for a variety of claims. It can be ordered directly and only on purchase of a new car. Choose from nine combinations of service life and mileage. For more information, please contact your Audi partner.

^[1] Please note: The systems work only within system limits and support the driver. However, the driver remains responsible for driving the vehicle and is required to be attentive.

^[2] Only available for Western Europe. ^[3] Please consult your Audi partner or national Audi website to find out more about the special features of the ceramic brake.

Model	RS 7 Sportback
Engine type	V8 petrol engine with direct fuel injection and turbocharging
Displacement in cc (valves per cylinder)	3,993 (4)
Max. output ¹ in kW at rpm	412/5,700-6,600
Max. torque in Nm at rpm	700/1,750-5,500
Power transmission	
Drive type	quattro® permanent all-wheel drive
Transmission type	8-speed tiptronic
Weights/capacities	
Unladen weight ² in kg	2,005
Gross vehicle weight in kg	2,515
Permissible roof load limit in kg	100
Fuel tank capacity, approx. in l	65
Performance/consumption³	
Top speed in km/h	250 ⁴
Acceleration 0-100 km/h in s	3.9
Fuel grade	Sulphur-free SuperPlus 98 RON ⁵
Fuel consumption ⁶ in l/100 km	
urban	13.3
extra-urban	7.3
combined	9.5
CO ₂ emissions ⁶ in g/km	
urban	308
extra-urban	170
combined	221
Emission standard	EU6

Explanatory notes

- ¹ The figure given was calculated using the specified measuring procedure (current version of UN-R 85).
- ² Unladen vehicle weight includes driver (75 kg) and fuel tank 90 % full, calculated in accordance with the current version of Reg. (EU) 1230/2012. Optional equipment may increase the car's unladen weight and drag coefficient, whereupon the possible payload limit and the top speed will be reduced accordingly.
- ³ A vehicle's fuel consumption and CO₂ emissions and deviations from the figures given do not just depend on how efficiently the vehicle uses the fuel, but are also influenced by driving behaviour and other non-technical factors. CO₂ is the greenhouse gas primarily responsible for global warming.
- ⁴ Regulated.
- ⁵ We recommend using sulphur-free SuperPlus unleaded RON 98 fuel complying with DIN EN 228. If this is not available, use sulphur-free super unleaded RON 95 fuel complying with DIN EN 228; power output will be slightly reduced. Unleaded RON 95 fuel with a maximum ethanol content of 10 % (E10) can generally be used. Fuel consumption details refer to operation with RON 95 fuel complying with 692/2008/EC.
- ⁶ The figures given were calculated using the specified measuring procedures. The figures do not refer to one individual vehicle and do not form part of any offer, but rather should be used purely for purposes of comparison between the different vehicle models.

Important note

Special information about the wheels: Wheels with gloss turned finish as well as polished or partly polished aluminium wheels must not be used in wintry road conditions. For manufacturing reasons, these wheel surfaces do not have sufficient corrosion protection for such use and they can be damaged permanently by road salt or similar.

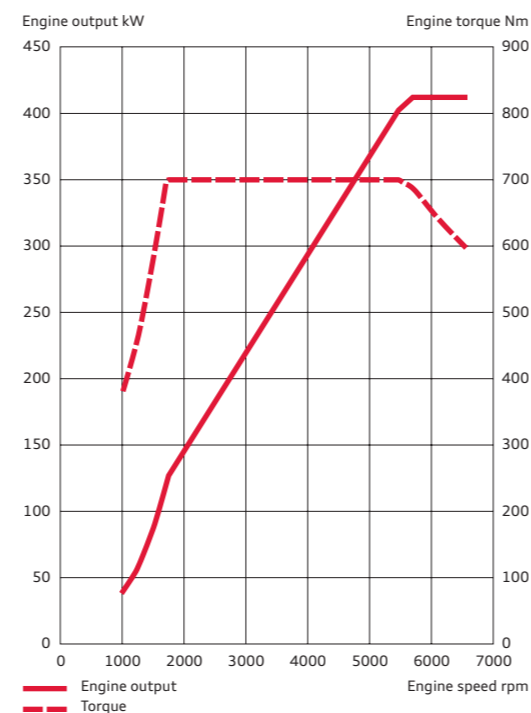

Audi RS 7 Sportback

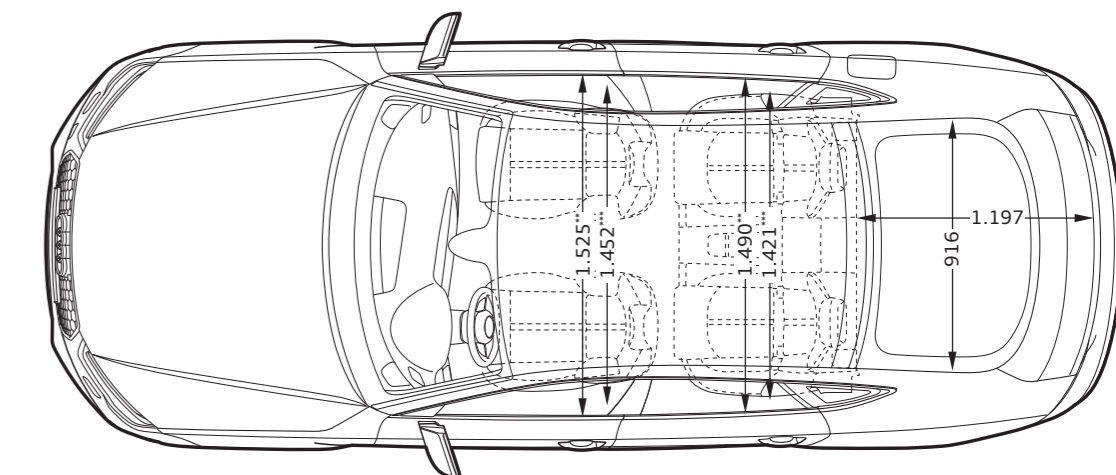
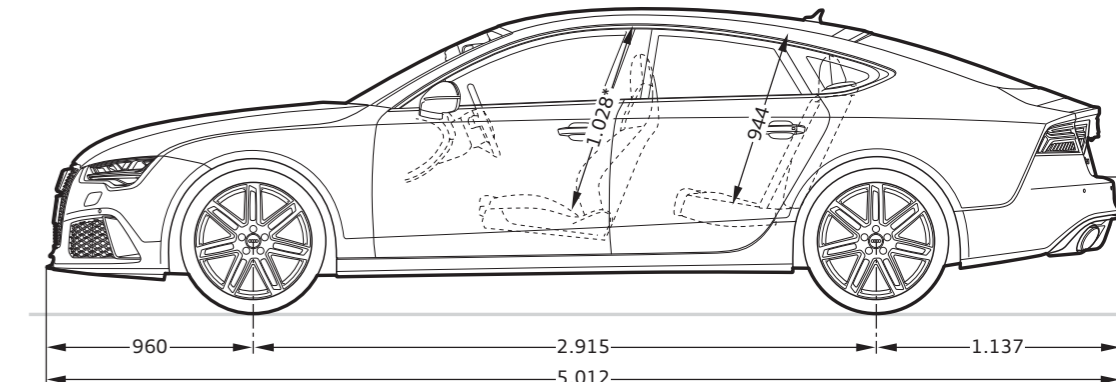
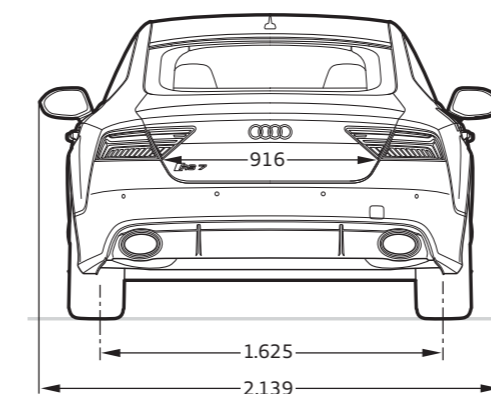
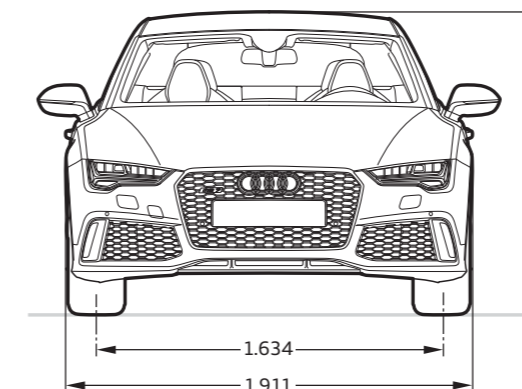

Dimensions in millimetres.













Dimensions were measured with vehicle at unladen weight.

Luggage compartment volume 535/1,390 l (second value with rear seat backrest folded down and vehicle loaded up to roof height).





Turning circle approx. 11.9 m.

*Maximum headroom. **Elbow room width. ***Shoulder room width.

Solid paint finish	38
 Nardo grey	<input type="checkbox"/>
Metallic paint finishes	39
 Glacier white, metallic	<input checked="" type="checkbox"/>
 Floret silver, metallic	<input checked="" type="checkbox"/>
 Mythos black, metallic	<input checked="" type="checkbox"/>
Pearl effect paint finishes	39
 Daytona grey, pearl effect	<input checked="" type="checkbox"/>
 Misano red, pearl effect	<input checked="" type="checkbox"/>
 Sepang blue, pearl effect	<input checked="" type="checkbox"/>
Crystal effect paint finishes	39
 Prisma silver, crystal effect	<input checked="" type="checkbox"/>
 Panther black, crystal effect	<input checked="" type="checkbox"/>
Matt effect paint finishes	39
 Daytona grey, matt effect	<input checked="" type="checkbox"/>
 Audi exclusive matt effect paint finishes	<input checked="" type="checkbox"/>
Customised paint finishes	39
 Audi exclusive customised paint finishes	<input checked="" type="checkbox"/>
Wheels/tyres	41
 20" forged aluminium wheels in 7-twin-spoke design, gloss turned finish ¹	<input type="checkbox"/>
 21" cast aluminium wheels in 5-spoke blade design	<input checked="" type="checkbox"/>
 21" cast aluminium wheels in 5-spoke blade design in matt titanium look, gloss turned finish ¹	<input checked="" type="checkbox"/>

 21" cast aluminium wheels in 5-spoke blade design in gloss black, gloss turned finish ¹	<input checked="" type="checkbox"/>
 20" cast aluminium winter wheels in 7-twin-spoke design	<input checked="" type="checkbox"/>
 21" cast aluminium winter wheels in 5-spoke blade design	<input checked="" type="checkbox"/>
Tyre pressure monitoring system	<input type="checkbox"/>
Tyre repair kit	<input type="checkbox"/>
Anti-theft wheel bolts	<input type="checkbox"/>
Vehicle tool kit	<input type="checkbox"/>
Vehicle jack	<input checked="" type="checkbox"/>
Seats	42
RS sport seats, front	<input type="checkbox"/>
Customised contour seats, front	<input checked="" type="checkbox"/>
Seat upholstery for RS sport seats, front	43
 Alcantara/leather, black, with diamond pattern in black	<input type="checkbox"/>
 Valcona leather, black, with honeycomb pattern in black	<input checked="" type="checkbox"/>
 Valcona leather, black, with honeycomb pattern in rock grey	<input checked="" type="checkbox"/>
 Valcona leather, black, with honeycomb pattern in crimson red Audi exclusive	<input checked="" type="checkbox"/>
 Valcona leather, lunar silver, with honeycomb pattern in rock grey	<input checked="" type="checkbox"/>
 Audi exclusive leather upholstery and trim	<input checked="" type="checkbox"/>
Seat upholstery for customised contour seats, front	43
 Valcona leather, black	<input checked="" type="checkbox"/>
 Valcona leather, black, perforated ²	<input checked="" type="checkbox"/>
 Audi exclusive leather upholstery and trim	<input checked="" type="checkbox"/>

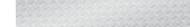
Leather upholstery and trim	44
Alcantara/leather combination	<input type="checkbox"/>
Valcona leather upholstery and trim with honeycomb pattern	<input checked="" type="checkbox"/>
Valcona leather upholstery and trim	<input checked="" type="checkbox"/>
Audi exclusive leather upholstery and trim (package 1) in Valcona leather	<input checked="" type="checkbox"/>
Audi exclusive leather upholstery and trim (package 2) in Valcona leather	<input checked="" type="checkbox"/>
Audi exclusive piping for customised contour seats	<input checked="" type="checkbox"/>
Audi exclusive leather upholstery and trim (package 1) in Alcantara/Valcona leather	<input checked="" type="checkbox"/>
Audi exclusive leather upholstery and trim (package 1) in Valcona leather with honeycomb pattern	<input checked="" type="checkbox"/>
Audi exclusive leather upholstery and trim (package 2) in Valcona leather with honeycomb pattern	<input checked="" type="checkbox"/>
Audi exclusive design package in Valcona leather with honeycomb pattern	<input checked="" type="checkbox"/>
Leather packages	44
Leather-covered armrests in the door trims	<input type="checkbox"/>
Leather-covered steering wheel airbag cover	<input checked="" type="checkbox"/>
Audi exclusive leather package including airbag cover	<input checked="" type="checkbox"/>
Audi exclusive extended leather package	<input checked="" type="checkbox"/>
Audi exclusive leather-covered seat trims	<input checked="" type="checkbox"/>
Seating comfort	45
Front seats, electrically adjustable, including memory function for the driver seat	<input checked="" type="checkbox"/>
4-way lumbar support for the front seats	<input type="checkbox"/>
Seat heating, front	<input checked="" type="checkbox"/>
Seat heating, front and rear	<input checked="" type="checkbox"/>
Seat ventilation, front	<input checked="" type="checkbox"/>
Massage function, front	<input checked="" type="checkbox"/>
Centre armrest, front	<input type="checkbox"/>
Seats in the rear	45
RS sport seats in the rear	<input type="checkbox"/>
RS sport seats in the rear including fold-out centre armrest	<input checked="" type="checkbox"/>
Rear seat system with 2 seats	<input checked="" type="checkbox"/>

Headlinings	45
Headlining in cloth	<input type="checkbox"/>
Headlining in Alcantara, black	<input checked="" type="checkbox"/>
Audi exclusive headlining in Alcantara, black, with coloured stitching	<input checked="" type="checkbox"/>
Inlays	47
 Carbon	<input type="checkbox"/>
 Piano finish, black	<input checked="" type="checkbox"/>
 Aluminium/Beaufort wood, black	<input checked="" type="checkbox"/>
 Aluminium race	<input checked="" type="checkbox"/>
 Matt brushed aluminium	<input checked="" type="checkbox"/>
 Audi exclusive wood inlays	<input checked="" type="checkbox"/>
Equipment packages	48
Comfort package	<input checked="" type="checkbox"/>
Dynamic package	<input checked="" type="checkbox"/>
Dynamic package plus	<input checked="" type="checkbox"/>
Headlights/interior light	48
LED headlights	<input type="checkbox"/>
Light/rain sensor	<input type="checkbox"/>
High-beam assist	<input checked="" type="checkbox"/>
Audi Matrix LED headlights	<input checked="" type="checkbox"/>
LED rear lights with dynamic indicators	<input type="checkbox"/>
Adaptive brake light	<input type="checkbox"/>
Ambient lighting	<input type="checkbox"/>
Exterior design	48
Model name/logo	<input type="checkbox"/>
Audi Singleframe	<input type="checkbox"/>
RS bumper	<input type="checkbox"/>
Sill extensions	<input type="checkbox"/>
Trim strips	<input type="checkbox"/>

Standard equipment Optional equipment

Country-specific variations possible. Please find out from your local Audi partner which equipment is standard and what optional equipment is available in your country.

More detailed descriptions of a selection of items from the equipment range can be found from page 34 onwards.

¹Please note the special information relating to wheels on page 56. ²Only available in conjunction with seat ventilation, front.

Exterior design (continued)	48
Engine cover with carbon trim	■
Rear spoiler	□
Matt aluminium styling package including air inlet duct with quattro® logo	■
Gloss black styling package including air inlet duct with quattro® logo	■
Carbon styling package including air inlet duct with quattro® logo	■
Interior design	49
Instrument panel trim in piano finish look, black	□
Aluminium-look interior	□
Floor mats, front and rear, in black	□
Audi exclusive floor mats with RS 7 logo	■
Audi exclusive floor mats with RS 7 logo and coloured leather piping	■
Audi exclusive floor mats	■
Audi exclusive carpet and floor mats	■
Pedals and footrest in stainless steel	□
Door sill trims with aluminium inlays	□
Steering wheels/controls	49
RS multifunction sport leather steering wheel in 3-spoke design, flattened at the bottom	□
RS multifunction sport leather steering wheel in 3-spoke design	■
RS multifunction sport leather steering wheel in 3-spoke design, heated	■
Electric steering wheel adjustment	□
RS selector lever knob in perforated leather	□
Audi exclusive leather controls	■
Audi exclusive controls in black suede	■
Mirrors	50
Exterior mirrors, electrically adjustable and heated, with integrated LED indicator	□
Exterior mirrors additionally with memory function	■
Exterior mirrors additionally electrically folding, with memory function	■
Exterior mirrors additionally electrically folding and automatically dimming on both sides, with memory function	■

Exterior mirror housings in matt aluminium look	□
Exterior mirror housings painted in body colour	■
Exterior mirror housings in gloss black	■
Exterior mirror housings in carbon	■
Interior mirror, manually dimming	□
Interior mirror, automatically dimming	■
Roof system	50
Slide-and-tilt glass sunroof	■
Glazing	50
Heat-insulating glass	□
Dark-tinted windows (privacy glazing)	■
Insulating/acoustic glass	■
Insulating/acoustic glass and dark-tinted windows (privacy glazing)	■
Sun visors, hinged and swivel-mounted	□
Sun screen	■
Climate control	50
4-zone deluxe automatic air conditioning	□
Closing systems	50
Remote control key with RS emblem	□
Engine start-stop button with red ring	□
Convenience key	■
Luggage compartment lid, electrically opening and closing	□
Convenience key with sensor-controlled release of the luggage compartment lid	■
Power-assisted door closing	■
Garage door opener (HomeLink)	■
Anti-theft alarm	□
Preparation for tracking system	■
Storage/transport	51
Storage compartments	□
Storage package	□

Luggage compartment	□
Through-loading facility	■
Through-loading facility with removable ski/snowboard bag	■
Reversible mat	■
Non-smoker version	□
Cigarette lighter and ashtray	■
MMI®/navigation/display instruments	51
RS instrument cluster	□
Driver information system with colour display	□
Attention assist	□
Head-up display	■
MMI® navigation plus with MMI touch	□
Entertainment	52
Digital Audio Broadcasting	■
Digital TV reception	■
Audi music interface	□
DVD/CD changer	■
Audi sound system	□
Bose Surround Sound	■
Bang & Olufsen Advanced Sound System	■
Preparation for Rear Seat Entertainment	■
Communication	52
Audi connect	■
Bluetooth interface	□
Audi phone box	■
Assistance systems	53
Hold assist	□
Parking system plus	□
Park assist	■

Reversing camera	■
Front and reversing cameras	■
Audi pre sense basic	■
Cruise control	□
adaptive cruise control with Stop&Go function including Audi pre sense front	■
Audi side assist including Audi pre sense rear	■
Audi active lane assist	■
Assistance package including Audi pre sense plus	■
Night vision assistant	■
Camera-based speed limit display	■
Driving dynamics/brakes	54
Audi drive select	□
RS adaptive air suspension	□
RS sport suspension plus with Dynamic Ride Control (DRC)	■
quattro®	□
quattro® with sport differential	■
tiptronic	□
Electromechanical power steering	□
Dynamic steering	■
RS brake system	□
Brake callipers painted gloss black	□
Brake callipers painted gloss red	■
Ceramic brake	■
Electromechanical parking brake	□
Top speed increased to 280 km/h	■
Technology/safety	55
Body, galvanised, in aluminium hybrid construction	□
Antilock Brake System (ABS) with Electronic Brake Force Distribution (EBD)	□
Anti-Slip Regulation (ASR)	□
Electronic Differential Lock (EDL)	□

□ Standard equipment ■ Optional equipment

Country-specific variations possible. Please find out from your local Audi partner which equipment is standard and what optional equipment is available in your country.

More detailed descriptions of a selection of items from the equipment range can be found from page 34 onwards.

Technology/safety (continued)	55
Electronic Stabilisation Control (ESC)	<input type="checkbox"/>
RS exhaust system	<input type="checkbox"/>
RS sport exhaust system	<input checked="" type="checkbox"/>
75 l fuel tank	<input checked="" type="checkbox"/>
Recuperation	<input type="checkbox"/>
Start-stop system	<input type="checkbox"/>
Airbags	<input type="checkbox"/>
Side airbags, front, and head airbag system	<input type="checkbox"/>
Side airbags, rear	<input checked="" type="checkbox"/>
Side impact protection in the doors	<input type="checkbox"/>
Integrated head restraint system	<input type="checkbox"/>
Safety steering column	<input type="checkbox"/>
Seat belts	<input type="checkbox"/>
Seat belts, crimson red	<input checked="" type="checkbox"/>
Audi exclusive seat belts	<input checked="" type="checkbox"/>
Child-proof lock for the rear doors	<input type="checkbox"/>
ISOFIX child seat mounting and top tether for the rear seats	<input type="checkbox"/>
ISOFIX child seat mounting for the front-passenger seat	<input checked="" type="checkbox"/>
First-aid kit	<input checked="" type="checkbox"/>
Warning triangle	<input checked="" type="checkbox"/>
Audi Extended Warranty	55
Audi Extended Warranty	<input checked="" type="checkbox"/>

Equipment for the Audi RS 7 Sportback illustrated (p. 4–21):

Paint finish: Daytona grey, pearl effect





Wheels: cast aluminium wheels in 5-spoke blade design

Seats/seat upholstery: RS sport seats, front, in Valcona leather, black, with honeycomb pattern in rock grey

Inlays: carbon

Classifications of tyre parameters

The table shows the range of fuel efficiency, wet grip and exterior noise emission classes for the different tyre sizes of the Audi RS 7 Sportback.

	Tyre size	Fuel efficiency class	Wet grip class	Exterior noise emission class
Summer tyres	275/35 R 20	E	A	73 
	275/30 R 21	F–E	B–A	73–70  – 
Winter tyres	245/40 R 20	E	C	73 
	275/30 R 21	C	C	72 

It is not possible to order a specific tyre. Ask your Audi partner about the range of tyres available in your country.

Standard equipment Optional equipment

Country-specific variations possible. Please find out from your local Audi partner which equipment is standard and what optional equipment is available in your country.

More detailed descriptions of a selection of items from the equipment range can be found from page 34 onwards.



Responsibility

Living up to our responsibilities is a principle that is firmly anchored in Audi strategy. Alongside commercial success and international competitiveness, our responsibility toward company employees and society as a whole is a key consideration, as is protecting the environment and conserving resources. And what is true in the details – our catalogues are printed on FSC-certified paper – also holds in general: Audi develops cars that are not only sporty and emotive but also ever more efficient. In the long run, Audi

wants its products to allow CO₂-neutral mobility. Seeing to it that production in Audi plants gradually becomes CO₂-neutral is another aspect of our comprehensive approach. Audi is also committed to society – particularly in the fields of education, technology and social projects. At Audi, sustainability is closely linked with how we see the future: the Audi Urban Future Initiative sees Audi working with international experts to get to the root of future urban challenges and trends in mobility.



Discover the world of Audi.



The Audi experience

The fascination of Audi can be experienced in many different ways. Audi City Berlin, Audi City London and Audi City Beijing, for example, give you digital access to all models at their actual size and in real time. And of course it is always worth visiting one of the major motor shows. This is where Audi always presents its new models and invites you to take a look at how the future is being shaped with "Vorsprung durch Technik". Anyone interested in seeing how Audi is already putting this into practice will find fascinating insight in the "Vorsprung durch Technik" online special at www.audi.com. But a look back can also be rewarding: at the Audi museum mobile in Ingolstadt, history and high-tech go hand in hand. A total of 130 historic exhibits and modern forms



of presentation make for a thrilling symbiosis. Plus, Audi driving experience allows you to live the excitement and countless possibilities of current Audi models. Here, pure driving enjoyment is combined with valuable learning effects. This is ensured by a team of specially trained and highly qualified instructors who provide practical tips to help you optimise your driving skills. All this can now also be enjoyed at the recently opened Audi driving experience center in Neuburg, near Ingolstadt. Facilities here include a circuit of up to 3.4 kilometres that features challenging combinations of bends, a 30,000 m² dynamic driving area and an offroad section where Q models can be put through their paces.

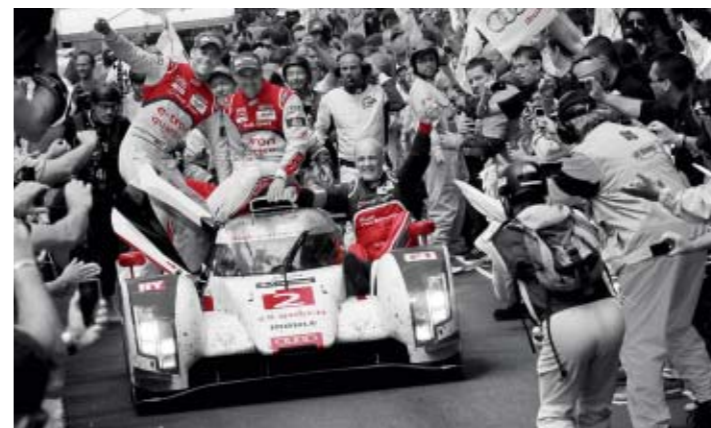

Choosing an Audi means choosing a brand that offers more. More individuality. More exclusivity. More fascination.



Team spirit

Motorsport is a driving force behind the brand. For years Audi has been among the champions in various racing series, for instance the 24 Hours of Le Mans or the DTM German Touring Car Masters. The values that are crucial in many different areas of sport are also central ones for Audi: precision, passion and technology. No coincidence then that Audi has been sponsoring sporting events for

many years. In the world of winter sports, for example, Audi has been the main sponsor of the German Ski Association (DSV) for almost three decades and has also partnered 16 other national alpine teams. In football, we support national and international teams. And Audi is also a partner for the German Olympic Sports Confederation.

www.audi.com

Information on all the topics mentioned above can be found on our website: www.audi.com.



www.audi.com



configurator.audi.com



www.audi.com/vorsprung-durch-technik



www.audi.com/driving



www.audi.com/cr

quattro GmbH
85045 Ingolstadt
www.audi.com
Valid from April 2015

Printed in Germany
558/1162.00.18



The models and equipment versions illustrated and described in this brochure and some of the services listed are not available in all countries. Some of the cars illustrated are equipped with optional equipment for which an extra charge is made. Details concerning the delivery specifications, appearance, performance, dimensions and weights, fuel consumption and running costs of the vehicle were correct to the best of our knowledge at the time of going to press. Deviations from the colours and shapes shown in the illustrations may occur. No liability is accepted for errors and printing errors. The right to introduce modifications is reserved. Not to be reproduced, including in part, without the written approval of AUDI AG.

This brochure is printed on paper made from pulp bleached without the use of chlorine.