



A7

Audi A7 Sportback
Audi S7 Sportback

Vorsprung durch Technik **Audi** 



		Page	
Fascination			
4	Audi A7 Sportback	22	Audi S7 Sportback
Technology			
34	Innovations	40	quattro®
36	Audi ultra	42	Audi Matrix LED headlights
38	Audi connect	44	Intelligent performance
46		46	Dynamics
48		48	Assistance systems
50		50	Complexity
Equipment			
54	Style guides	68	Audi exclusive
56	S model	70	Paint finishes
58	Audi ultra	72	Wheels/tyres
60	Engines	74	Seats/seat upholstery
62	S line	79	Headlinings
64	Audi design selection	80	Inlays
66	Audi exclusive line	82	Lights
83		83	Design
83		83	Steering wheels/controls
85		85	Comfort
87		87	Infotainment
90		90	Assistance systems
93		93	Technology/safety
95		95	Audi Extended Warranty
Other			
96	Audi Genuine Accessories	102	Dimensions
98	Technical data	104	Index
112		112	The fascination of Audi

The equipment for the vehicles illustrated in the Fascination section can be found on page 111.

The fuel consumption and CO₂ emission figures as well as the efficiency classes can be found from page 98 onwards.

Nothing is more convincing than a clear line.

One thrilling vehicle combining the purist charm of a saloon, the distinct versatility of an Avant and the passionate dynamism of a coupé. Top sporting performance. Innovative technology. Impressive efficiency. The new Audi A7 Sportback. A unique car.

The fuel consumption and CO₂ emission figures as well as the efficiency classes can be found from page 98 onwards.









Nothing is more inspiring than the view ahead.

Pure form, clear lines.

Every millimetre of the new Audi A7 Sportback is set to impress.

The characteristic dynamic line stretches across the whole length of the vehicle. Harmoniously in tune with wide side sills. Sporty and taut. The perfect balance of purist lightness and flowing lines. A statement of dynamism and elegance.

The fuel consumption and CO₂ emission figures as well as the efficiency classes can be found from page 98 onwards.

A7

Audi A7 Sportback

Sportiness, progressively interpreted.
By a design that stirs emotions.
From heightened anticipation to
genuine enthusiasm. Enhanced
through extraordinary details.

An initial impression of elegance and
sophistication, emphasised by the Audi
Singleframe with horizontal chrome
struts. Wide. Flat. Giving the headlights
a look of tension and power. An
appearance that emanates strength.

Radiating confidence all the way back
to the muscular rear with diffuser in a
contrasting colour. Sporty, elegant
tailpipes with a trapezoidal design and
a striking spoiler edge.

The fuel consumption and CO₂ emission
figures as well as the efficiency classes
can be found from page 98 onwards.









Nothing is more fulfilling than
the feeling that you have done
everything right.

The new A7 Sportback is an impressively innovative vehicle concept. Its coupé-like design demonstrates surprisingly practical suitability. Take the wide opening tailgate and space for up to 1,390 litres of luggage, for example. Emotion meets functionality. A vehicle for everyday use – and for very special moments.

The fuel consumption and CO₂ emission figures as well as the efficiency classes can be found from page 98 onwards.



Attractive aluminium wheels create individual highlights.



The fuel consumption and CO₂ emission figures as well as the efficiency classes can be found from page 98 onwards.



Streamlined LED rear lights confidently emphasise the vehicle width. Dynamic indicators included as standard.



With 18 individual diodes, the LED daytime running lights in the headlights ensure powerful illumination. Available as an option: Audi Matrix LED headlights for optimum illumination of the road.

Striking exterior mirrors are stylishly integrated into the dynamic overall appearance.



The fuel consumption and CO₂ emission figures as well as the efficiency classes can be found from page 98 onwards.

Nothing is more relaxing than a moment of peace.

Take a seat, breathe in and enjoy. The interior ambience rounds off the exterior elegance and is further accentuated by exclusive inlays. In high-quality wood if so desired.

Not just a passenger compartment, but also an intelligent interior concept. It embraces both driver and front passenger, giving them a sense of security. The centre console is angled towards the driver. Everything in view and under control. With the aid of aluminium-look buttons, among other things. Now available with the new generation of infotainment, for example MMI navigation plus with MMI touch. In addition, numerous Audi connect services are available and have been integrated in a user-friendly way. And thanks to MMI touch, they can be operated intuitively using just one finger.





Sit back and relax on comfortable seats. Feel their excellent support and high-quality materials. Customised contour seats in leather with memory function are available as an option for the driver and front passenger – these can be adjusted from sporty to comfortable and the settings saved and called up again any time with the memory function.

Plenty of room for personal development. Supported by the folding centre armrest and plenty of storage compartments in the frameless doors. The rear seat bench can be easily split and folded forwards, for more comfort or even more luggage space. The rear seat bench fully folded down produces a luggage capacity of up to 1,390 litres. This can be used conveniently thanks to the standard electric tailgate which is large and opens wide.

The fuel consumption and CO₂ emission figures as well as the efficiency classes can be found from page 98 onwards.







Nothing is stronger than you own drive.

Delivering an efficient yet powerful performance. The TFSI, TDI and FSI® engines for the new Audi A7 Sportback.

With quattro permanent all-wheel drive as an option. Channelling power to where it is needed. To the road. Combining poise with powerful forward momentum. Optionally available with ESP and electronic axle-differential lock for even more dynamism and agility. To ensure you stick to your course even with a very sporty driving style. Stability is enhanced by the harmoniously integrated rear spoiler. This extends automatically when the vehicle reaches 130 km/h – or at the touch of a button whenever you want. For improved downforce and sporty aesthetics.

The fuel consumption and CO₂ emission figures as well as the efficiency classes can be found from page 98 onwards.

Sportiness that can be seen and felt.
The new Audi A7 Sportback boasts outstanding dynamism and superb efficiency.

Its intelligent lightweight design helps reduce fuel consumption and cut emissions. Supported when stationary by the start-stop system which switches off the engine automatically. As soon as the stopping process is initiated. The efficiency program also offers tips on how to drive more economically. These appear conveniently in the driver information system.

Audi drive select offers even greater efficiency. Choose your own preferred setup by selecting one of five modes – from comfortable to sporty. Or make particularly energy-saving headway with the efficiency mode. In conjunction with S tronic, there is even a freewheel mode, which switches early on to idle once the accelerator pedal is released.

An impressive combination of athletic ability and energy efficiency that has been consistently followed through. And accomplished with a clear line in a unique car.
The new Audi A7 Sportback.

The fuel consumption and CO₂ emission figures as well as the efficiency classes can be found from page 98 onwards.

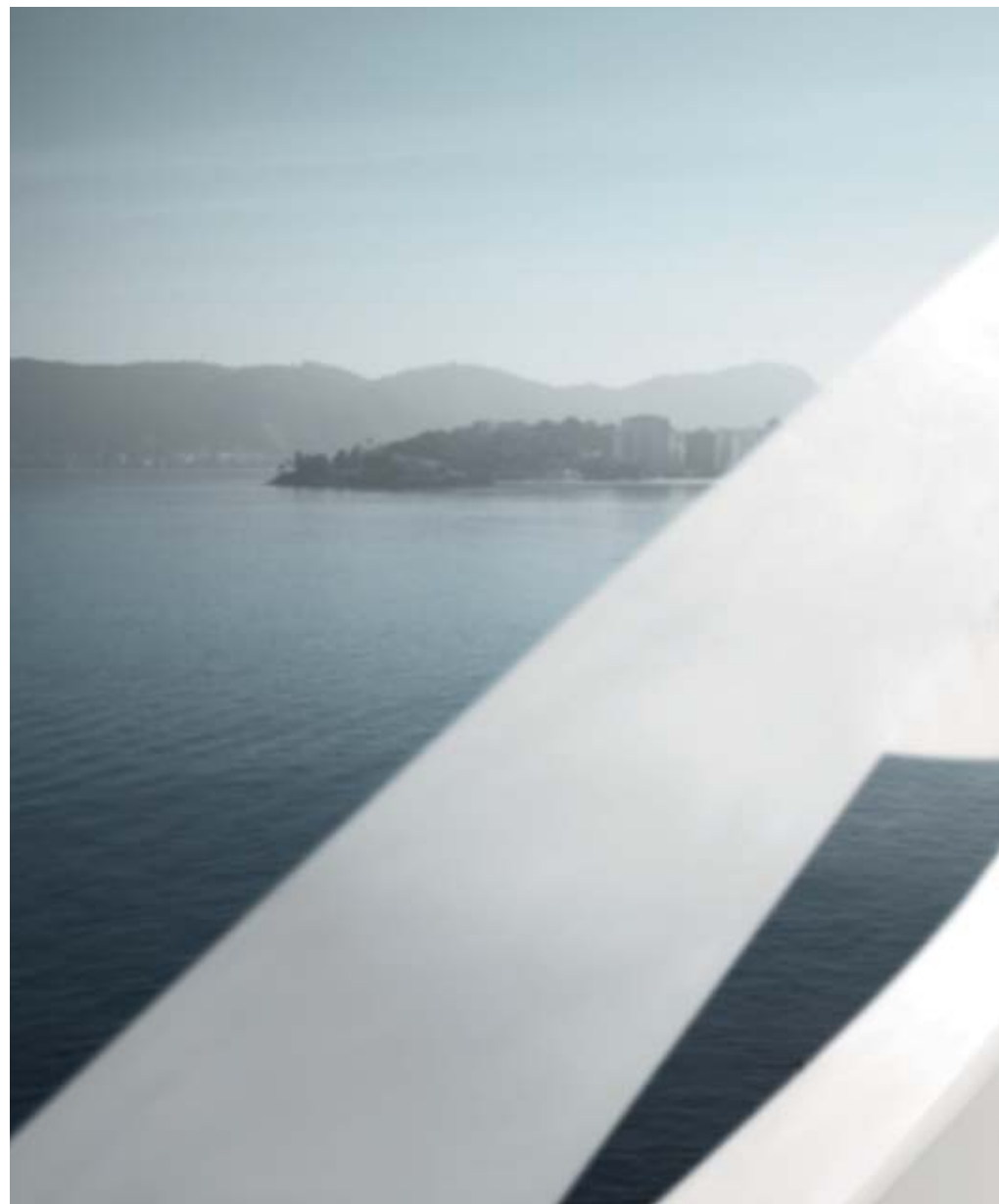







Design that fascinates. Power that impresses.

Passion at the very first glance. The new Audi S7 Sportback. Specially designed headlights beam out from underneath the impressive bonnet, flanked at the sides by powerful sills. The result is a look that promises pure dynamics. And that delivers on this promise too – with 8 cylinders and 331 kW. Rounded off with a breathtaking performance. Enjoy uncompromising sportiness, without sacrificing comfort or efficiency.

The fuel consumption and CO₂ emission figures as well as the efficiency classes can be found from page 98 onwards.

S7

Audi S7 Sportback

Top sporting performance. From our engineers.

Irresistible acceleration. Triggered by a brief press of the accelerator. From 0 to 100 km/h in 4.6 seconds. With ease. Powered by a masterpiece of German engineering: the 4.0 litre V8 TFSI engine. With innovative Audi cylinder on demand technology. Intelligent and efficient. Four of the eight cylinders shut down in the partial-load range. Without being noticed. The engine continues to run smoothly and powerfully regardless, reducing fuel consumption and cutting CO₂ emissions in the process.

The fuel consumption and CO₂ emission figures as well as the efficiency classes can be found from page 98 onwards.









Exceptional sportiness. Down to the last detail. Starting with the Singleframe and horizontal double chrome struts. Refined with the Audi S emblem. And rounded off with the black painted brake callipers that are typical of the S models. Clearly visible between the spokes of the optional 20-inch cast aluminium wheels.

The fuel consumption and CO₂ emission figures as well as the efficiency classes can be found from page 98 onwards.





Concentrated fascination.

Welcome on board. To high-quality S sport seats in the front. Optionally available in luxurious Valcona leather. And electrically adjustable as standard. Sporty looks included. Accentuated by the embossed S7 logo on the upper backrest. Superb lateral support, even for drivers with a more spirited driving style.

The fuel consumption and CO₂ emission figures as well as the efficiency classes can be found from page 98 onwards.

A decorative graphic element consisting of a complex, red, geometric pattern of overlapping lines and shapes, resembling a stylized architectural or mechanical structure.

The first shot of adrenaline comes when you get in. The spirit of racing in the air. The power lies in your hands. Multifunction sport leather steering wheel in 3-spoke design, with aluminium S7 emblem and aluminium-look shift paddles. Flanked by inlays in matt brushed aluminium. In carbon Atlas on request. Exclusive and sophisticated. Plus intuitive operation of the navigation system, media playback and comfort functions. Quite simply with a swipe of the finger. Thanks to the optionally available MMI navigation plus with MMI touch.

The fuel consumption and CO₂ emission figures as well as the efficiency classes can be found from page 98 onwards.

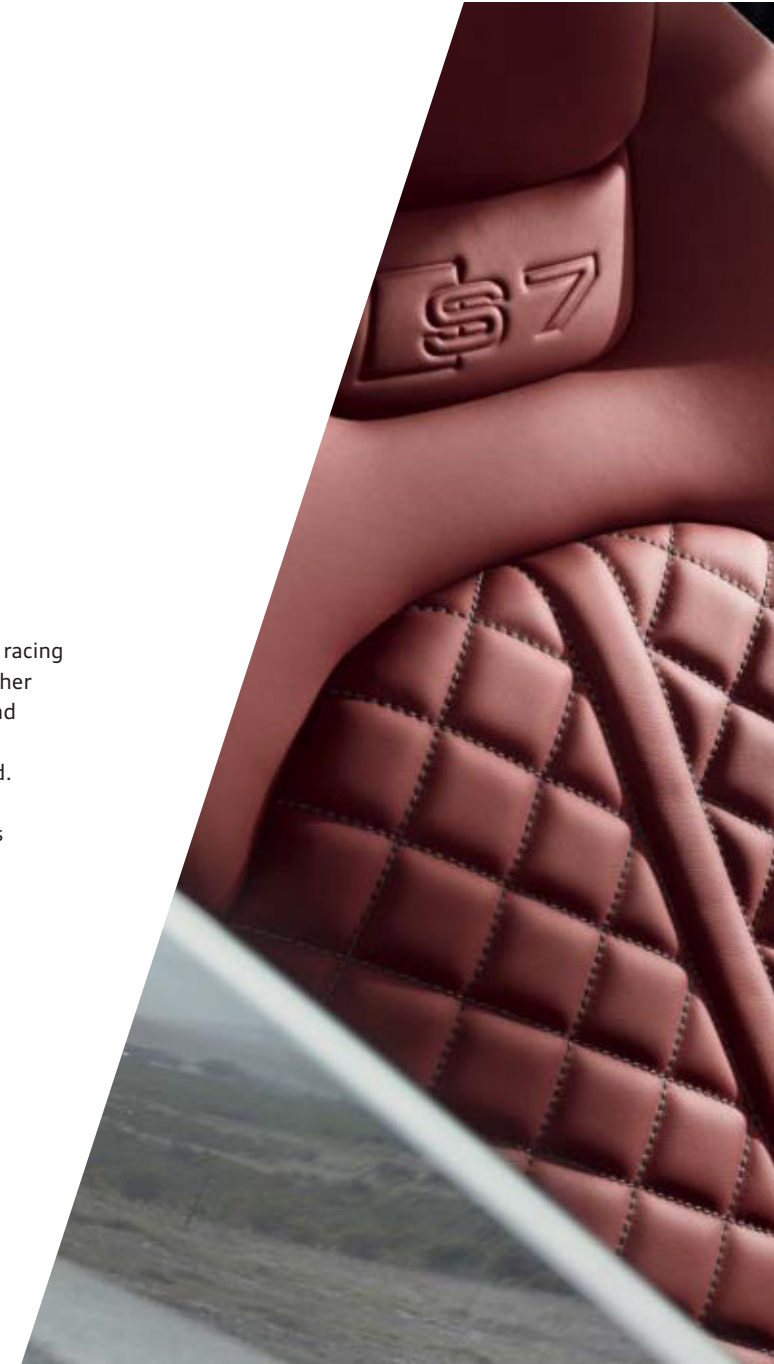





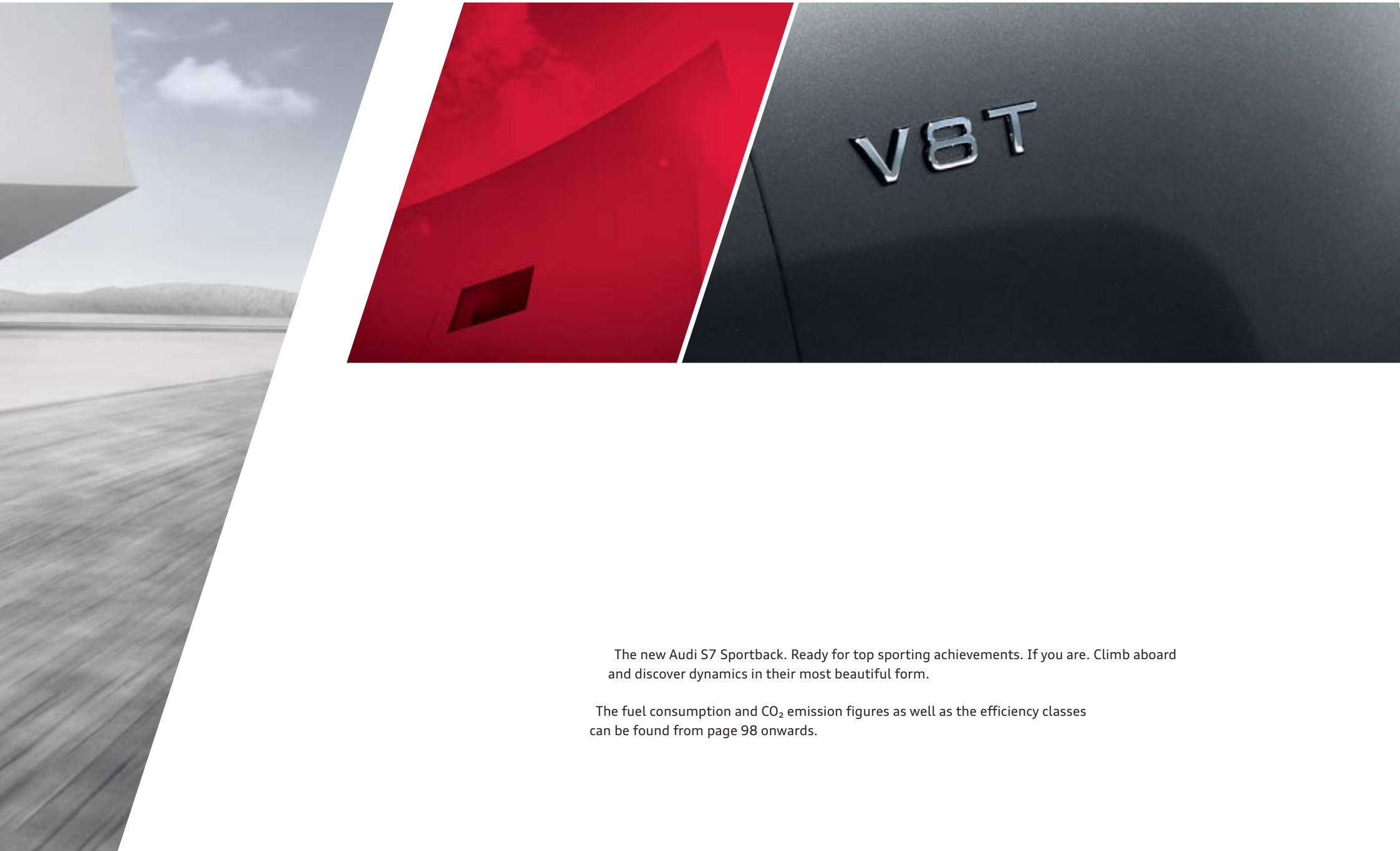

The new Audi S7 Sportback. Ready for top sporting achievements. If you are. Climb aboard and discover dynamics in their most beautiful form.

The fuel consumption and CO₂ emission figures as well as the efficiency classes can be found from page 98 onwards.

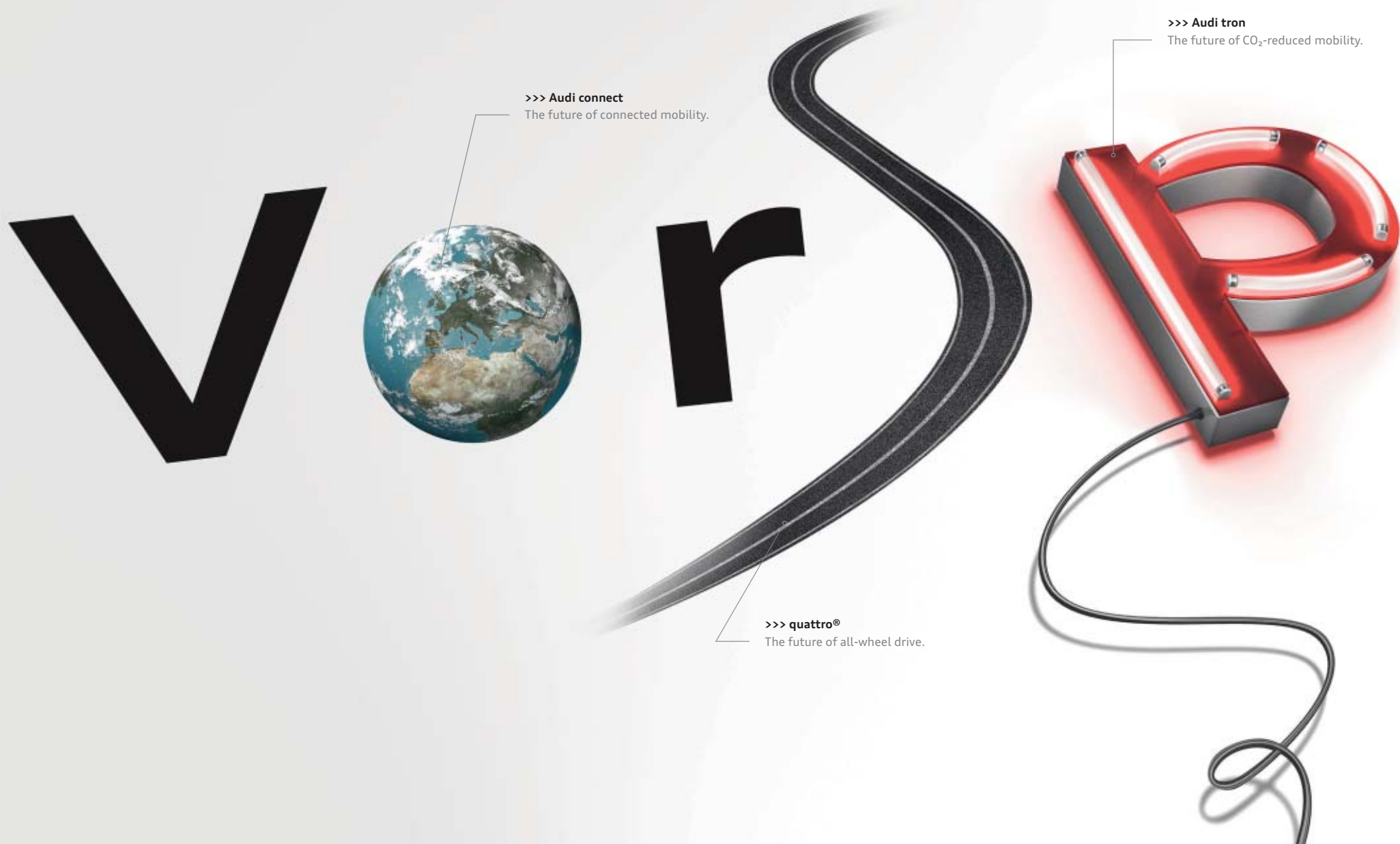

>>> **Audi connect**
The future of connected mobility.

>>> **quattro®**
The future of all-wheel drive.

>>> **Audi tron**
The future of CO₂-reduced mobility.



running

>>> Audi ultra

The future of efficient technologies.

>>> Design

Reshaping the future.

... durch Technik.

The world is constantly changing. Technology is advancing at an ever faster pace. And in the process, more and more opportunities are opening up to you – nowhere more so than in the field of mobility. We are playing an instrumental role in shaping this progress with Vorsprung durch Technik. Striving to provide you with technology that enriches your life. Making sure that we don't just satisfy your expectations of mobility both today and in the future, but continue to surpass them.

>>> Transmission expertise

Improved efficiency thanks to improved transmission ratios. A higher torque output makes longer ratios possible, especially in higher gears. For powerful torque in the low engine speed range which reduces consumption – yet has no adverse effects on driving performance and sportiness.

>>> Aerodynamics

Less drag, more efficiency. Thanks to the consistently aerodynamic styling of the vehicle's lines, its underbody and spoiler edges – in order to achieve the best possible form for aerodynamic efficiency. Not forgetting tyres with reduced rolling resistance. All tested in the Audi wind tunnel at up to 300 km/h.

>>> Lightweight expertise

Less weight. More savings, power and endurance. Audi lightweight technology. What started with lightweight body construction has now made its way into nearly all areas, combining innovative materials such as aluminium, carbon and magnesium, intelligent design principles and resource-saving manufacturing processes into an overall concept.



>>> Recuperation

Braking that leads to even more efficient driving. With brake energy recovery (recuperation). Part of the kinetic energy produced when braking and coasting is temporarily stored in the vehicle's battery and then used when accelerating. Depending on the driving cycle, this can save up to 3 % of fuel.

Audi ultra

Perfectly combined.

The future of efficient technologies.







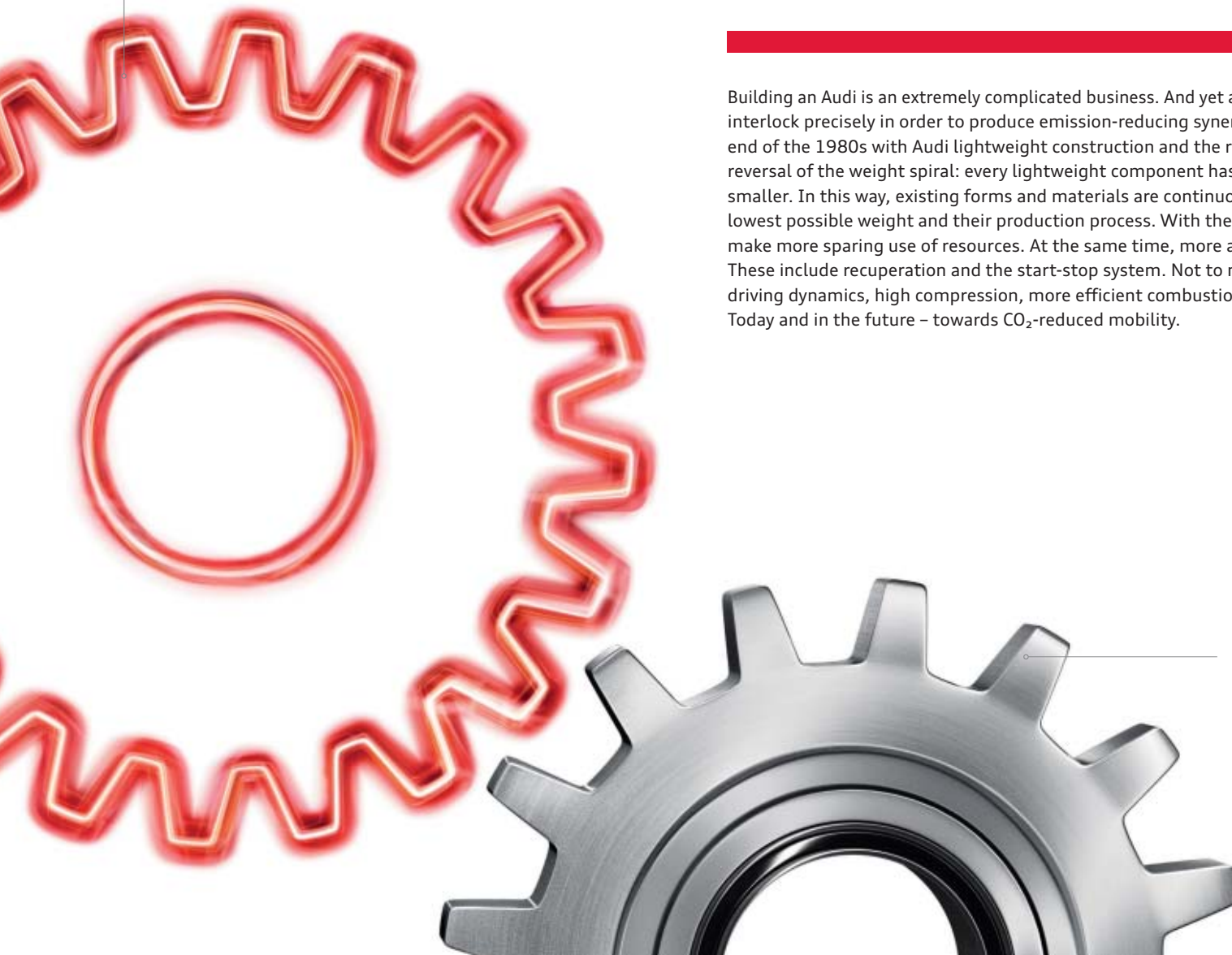



Building an Audi is an extremely complicated business. And yet a simple principle applies for all models: all vehicle components interlock precisely in order to produce emission-reducing synergies. What started in accordance with this principle at the end of the 1980s with Audi lightweight construction and the revolutionary Audi Space Frame (ASF®) is now known as the reversal of the weight spiral: every lightweight component has an impact on other components, which can in turn be made smaller. In this way, existing forms and materials are continuously being improved with regard to their functionality, the lowest possible weight and their production process. With the goal of building vehicles that are even more efficient and make more sparing use of resources. At the same time, more and more efficiency technologies are being built into an Audi. These include recuperation and the start-stop system. Not to mention progressive, efficient high-tech engines. For greater driving dynamics, high compression, more efficient combustion and lower CO₂ emissions. All this is known as Audi ultra. Today and in the future – towards CO₂-reduced mobility.



>>> Engine expertise

Powerfully and efficiently driven. By Audi ultra with efficiency technologies in the engine sector. Such as Audi cylinder on demand and the Audi valvelift system, which both reduce the amount of energy consumed by the engine, or clean diesel technology, which can help to reduce emissions.









Mobility & navigation

- 
Point-of-interest (POI) search with voice control
 in the Google™¹ database
- 
Traffic information online
 complements the dynamic route guidance with real-time traffic flow information for individual stretches of road
- 
myAudi – special destinations²
 The navigation system as a personal road atlas: import individual point-of-interest (POI) lists to the vehicle via the myAudi portal.
- 
Flight information
 Get information conveniently from inside your vehicle about departure and arrival times as well as the corresponding gates and search directly for flight numbers if you want.
- 
Train information
 Find departure and arrival times and the right platforms while you're on the road. (Also available for other types of public transport, e.g. underground railway)
- 
Country information²
 The legal regulations for a specific country, such as speed limits or whether it is compulsory to carry a high-visibility vest or display a motorway toll sticker, are displayed when crossing a border.
- 
Picturebook navigation
 GPS data from your photos get you to your destination.
- 
Fuel prices
 the cheapest petrol stations at your destination or in the vicinity
- 
Parking information
 Helps with looking for car parks and multi-storeys, plus – where available – information on prices and currently vacant spaces
- 
Navigation with Google Earth™¹ and Google Street View™¹
 uses high-resolution aerial and satellite images, photos and address information to guide you to your destination even more easily

- 
Map update online²
 The map version delivered can be updated free of charge with the first 5 navigation updates which are issued at intervals of 6 months. In conjunction with Audi connect, the update can be carried out online in the vehicle.
- 
Destination entry via myAudi or Google Maps™¹
 If you want, you can plan your navigation destinations from your PC or using a smartphone. myAudi and Google Maps or the Audi MMI connect app allow individual navigation destinations to be sent to the vehicle. When you start your journey, these can easily be loaded as your destination.

Communication

- 
Wi-Fi hotspot
 connects your mobile devices to the internet
- 
E-mail²
 can be transmitted to your Audi MMI and read out conveniently
- 
Text messages³
 displayed or conveniently read out to you and replies written using the dictation function
- 
Access to Facebook
 integrates your personal network into the cockpit. With text-to-speech and other convenient text functions
- 
Access to Twitter
 integrates the Twitter message service into the cockpit. With text-to-speech and other convenient text functions
- 
Access to smartphone voice control⁴
 such as Siri (iPhone 4s and higher). By pressing and holding the voice control button on the multifunction leather steering wheel you can access the voice control function of the Bluetooth-connected smartphone directly even while driving. This can be controlled safely and conveniently via your Audi's microphones and loudspeakers.



¹ Google and the Google logo are registered trademarks of Google Inc. ² Part of the optional MMI navigation plus with MMI touch. ³ Provided the mobile phone has the Bluetooth profile MAP (Message Access Profile). Please contact your Audi partner or visit www.audi.com/bluetooth for information on compatible mobile phones. ⁴ Requires the optional MMI navigation plus with MMI touch including voice control system and Bluetooth interface as well as multifunction leather steering wheel. ⁵ For information on when this feature will be available, please contact your Audi partner. Depending on country-specific availability. To use this feature you will generally require an account with a media streaming service. Additional costs may be incurred as a result. Availability, screen display and the cost of services vary depending on the country, model, device and tariff. For further legal information and notes on use, please see page 90 or visit www.audi.com/connect.

audi connect.

Audi connect

The future of connected mobility.

The world presents you with countless possibilities. The optional Audi connect enables you to make the most of many of them in digital form directly from your Audi. At the push of a button. Tailored to you. Thanks to myAudi and the services supported by Audi connect in your vehicle. In places all over the world. Intuitively, easily and conveniently.

myAudi – your personal control centre

provides you with password-protected access to www.audi.com/myaudi where, following one-off registration, you are able to put together the services supported by Audi connect that you require, and manage and configure them from the comfort of your own home. You can also use many of these services while out and about with your smartphone (Android 4.0 or higher, iOS 6 or higher) via the Audi MMI connect app.

Infotainment



Weather

forecasts and maps for the required destination



Online media streaming⁵

Via smartphone app, access to personal radio services and worldwide radio stations as well as connection of music streaming services which allow access to millions of songs. Music stored on the smartphone can also be accessed.



News online (individual)

Text and images about current world events, with text-to-speech function, can be configured individually.



City events

up-to-date information about events – e.g. at your destination



Travel information

sightseeing information – with a function for importing the destination to the navigation system



quattro[®]
**Stick to
the road.**

With quattro[®].

Have the road completely under control, thanks to permanent distribution of the drive force to all four wheels. Variably controlled by the centre differential. Always depending on the situation. Experience handling stability, dynamism and agility as never before and combat the effects of over- and understeer with quattro with optional sport differential. For increased traction and superior propulsive power. Tame any road. And always keep your eyes set on where you're heading. In bends. On straights. Over any surface. For a fascinating experience that sticks. To the road – and in your mind.





Audi Matrix LED headlights

See well.

Darkness is relative. The optional Audi Matrix LED headlights turn night into day. The all-new headlight technology produces a light colour similar to that of daylight. Bends are anticipated to illuminate them more clearly. Vehicles are detected and the light distribution of your new Audi A7 adapts according to the situation. This is all made possible by an array of sensors and a camera. As well as dimmable LEDs in an innovative arrangement – which, incidentally, are quite a sight in their own right.



Audi Matrix LED headlights won't thrill you only at night. The new lighting technology is quite a spectacle during the day, too, sometimes appearing as light points, sometimes as a dynamic light strip. Individually controllable LEDs. Perfectly adapted to the situation in hand. Showing the way ahead. An impressive sight, time and time again.

The fuel consumption and CO₂ emission figures as well as the efficiency classes can be found from page 98 onwards.

Look good.

Intelligent performance

Maximum power. Put to maximum use.

Every movement originates from something. Something that sets it off, an idea. The engine in your new Audi A7 Sportback can also be traced back to an initial spark of inspiration: higher power with lower fuel consumption. These apparently conflicting aims are reconciled in two revolutionary drive technologies: TDI and TFSI. Get acquainted with both of them. And then opt for the drive system that you feel most moved by.



The fuel consumption and CO₂ emission figures as well as the efficiency classes can be found from page 98 onwards.



TDI®

With their combination of direct injection and turbocharging, Audi TDI engines promise exceptional performance – thanks to their high torque output over the entire engine speed range with constant power build-up. They are renowned for being fuel-efficient and for reducing emissions. But they are incredibly dynamic too – letting you get the maximum out of any road.



TFSI®

Audi TFSI engines attain a particularly high compression rate. The result: outstanding efficiency combined with optimum performance. Substituting supercharging for cubic capacity has the effect of considerably reducing engine size and weight – while performance remains as impressively dynamic as ever. For power delivery that will win you over from the word go.

Audi cylinder on demand

Even cylinder heads can be intelligent, as Audi cylinder on demand proves. Four of the TFSI engine's eight cylinders automatically shut down in the partial-load range. This helps to lower fuel consumption at the same time as reducing emissions. Without the switchover even being noticed or impairing the driving dynamics.



>>> ESP with electronic axle-differential lock

The ESP stabilisation system with electronic axle-differential lock applies minimum brake pressure selectively if there is insufficient load on the inside front wheel. This braking action diverts the excessive torque to the outside wheel so that it can transmit more drive force to the road, thus improving traction.

>>> Audi drive select

Audi drive select lets you adapt the driving characteristics of the A7 Sportback to suit your requirements. At the push of a button. Sportier, more comfortable, more balanced, more economical or even individually tailored as you please. It's entirely up to you.

>>> tiptronic

The 8-speed automatic transmission with Dynamic Shift Program (DSP) ensures faster gear changes without any perceptible break in propulsive power.

>>> S tronic®

The sporty, efficient dual-clutch transmission allows you to switch gears with lightning speed without a noticeable break in propulsive power.

>>> adaptive air suspension

The electronically controlled air suspension acts individually at each of the 4 wheels and makes sure that the handling characteristics are barely affected, even when carrying heavy loads. Also available as a sport version for the S model with even stiffer damping.

>>> Dynamic steering

The dynamic steering enhances handling and driving comfort with speed-sensitive control of the steering ratio.

>>> quattro®

The permanent all-wheel-drive system distributes the drive forces to each individual wheel according to the driving situation for extra traction and dynamic performance.

>>> quattro® with sport differential

The quattro permanent all-wheel drive with electronically controlled sport differential guarantees superb agility and thrilling driving dynamics.

>>> Ceramic brake

The ceramic brakes fitted at the front and rear axles ensure excellent braking performance in any driving situation.



Dynamics

Dynamics

that will take hold of you.

Get in. Buckle up. Start the engine. Wherever you're heading, enthralling driving dynamics will power you there. For as you know, the world is your oyster once you get behind the wheel of your new Audi A7 Sportback. You decide the direction. The driving style. The pace. And you enjoy the satisfaction of knowing you have plenty in reserve. More than enough to get the very best from every drive.

The fuel consumption and CO₂ emission figures as well as the efficiency classes can be found from page 98 onwards.

You can find out which equipment features are available as standard or optional in your model by referring to the index starting on page 104.

>>> Audi pre sense basic

initiates preventive occupant protection measures in the event of an impending accident

>>> Camera-based speed limit display

recognises speed limits and notifies you of them via the driver information system and head-up display

>>> Audi active lane assist

helps you to keep in lane by means of gentle steering intervention when lane boundary markings are detected

>>> adaptive cruise control including Audi pre sense front

monitors the traffic ahead and automatically maintains a constant distance wherever possible

>>> Audi Matrix LED headlights

track the road ahead and illuminate it according to the situation with their innovative LED layout for even greater safety

>>> Audi side assist including Audi pre sense rear

helps you when changing lanes and initiates preventive protection measures when an impending rear-end collision is detected

>>> Night vision assistant

improves convenience at night thanks to its integrated thermal imaging camera, highlighting any pedestrians and larger wild animals detected

Assistance systems

Wherever you're heading, peace of mind will be your constant companion.

With the assistance systems in your new Audi A7 Sportback.

Each drive is different. Yet they all have one thing in common – the feeling of being protected that you get from every Audi. All driver assistance systems in your new Audi A7 Sportback help you during your journey and guarantee even greater comfort when you're on the road. Get to know the most important driver assistance systems.

>>> Head-up display

projects key information onto the windscreen at eye level so there is no need to take your eyes off the road

>>> Parking system plus with 360 degree camera

provides a better overview for parking and manoeuvring by offering a choice of different camera angles all around the vehicle

>>> Park assist with display of surroundings

helps you to manoeuvre in and out of parking spaces by taking charge of the steering temporarily

>>> Audi connect

Use all the optional services supported by Audi connect with the MMI navigation plus with MMI touch – quickly and easily. The intuitive operation of the MMI makes accessing internet-based functions remarkably straightforward.

>>> Navigation

With MMI navigation plus with MMI touch you can let yourself be guided to your destinations with even greater ease by the 3D map view and 3-dimensional display of places of interest and landmark buildings.

>>> Car

Control and alter driver assistance systems, vehicle settings as well as climate control and service functions quickly and easily using the MMI radio.

>>> Phone

Make phone calls safely and easily using the hands-free facility: simply select the number to dial from your contacts in the MMI or enter the number intuitively via the MMI touch.

>>> Media

Display the covers of your music collection on all available media sources such as jukebox, inserted SD cards, Audi music interface, CDs or DVDs.

MMI



>>> MMI® touch

MMI touch makes operating the individual components of the Multi Media Interface even easier. The touchpad can even be operated using just one finger.

Simplexity

The MMI® – intelligent, individual, intuitive.

Streamlined. Simple. Logical. The world of mobile infotainment completely redefined: the Multi Media Interface (MMI). Phoning, navigating or surfing the internet via Audi connect: all highly intuitive, highly functional and highly convenient – not least thanks to voice control. With the MMI in your new Audi A7 Sportback, everything will be child's play for you.

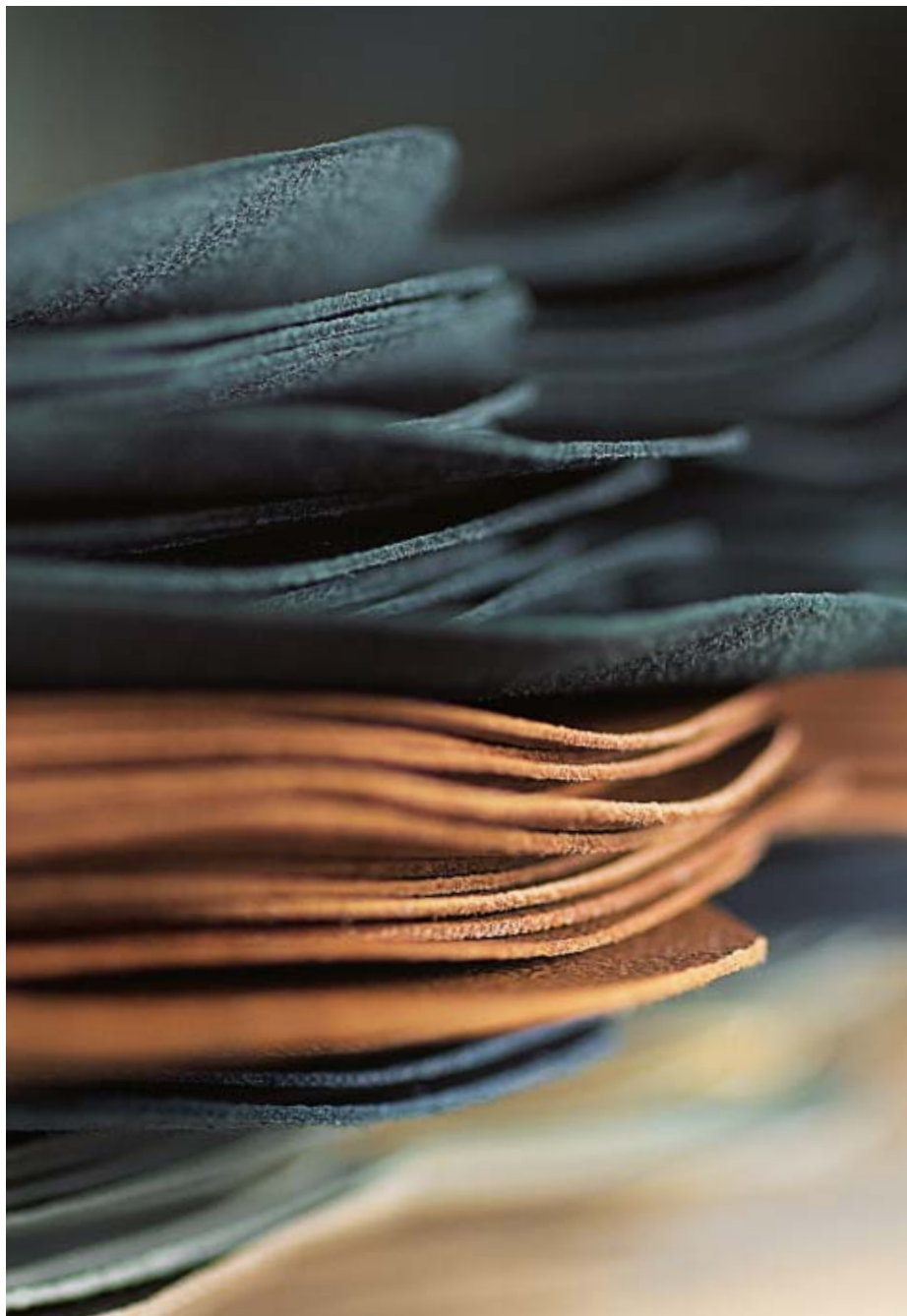



As unique as you are. The equipment options.

Sportiness, comfort, design, functionality – whatever you demand of your Audi, it offers you a wealth of custom options. Audi equipment versions are varied and high-quality and you can tailor them entirely to your needs.

Character takes on many forms. Here are two of them.

What makes an Audi your Audi? Vehicle equipment entirely tailored to your needs. There are a wide range of options available to you for giving your vehicle the exact touch you have in mind. More sportiness? More elegance? Let yourself be inspired.

Audi A7 Sportback in mythos black, metallic

Audi Matrix LED headlights

Audi Sport cast aluminium wheels
in 5-spoke blade design in matt titanium look,
gloss turned finish*

Sport seats, front, in Valcona leather, flint grey

Audi exclusive leather package including airbag cover

Inlays in piano finish, black.



The fuel consumption and CO₂ emission figures as well as the efficiency classes can be found from page 98 onwards. *Please note the special information relating to wheels on page 100.



**Audi S7 Sportback
in Sepang blue, pearl effect**

LED rear lights with dynamic indicators

Audi Sport cast aluminium wheels
in 5-twin-spoke design

S sport seats, front, in Valcona leather, black with
contrasting stitching and S embossing on the backrests

Inlays in aluminium/Beaufort, black.



Sportiness that can be seen and felt. Even when stationary.

S stands for sportiness. Your new Audi S7 Sportback is impressive proof of this. With extensive S-specific equipment. For a dynamic look. Sporty comfort. And superior performance. And you also have the option of further enhancing the S-factor. With optional equipment that is equally impressive to the senses.



The fuel consumption and CO₂ emission figures as well as the efficiency class can be found on page 100.

S7-specific standard equipment

Cast aluminium wheels in 5-parallel-spoke design (S design)

size 8.5 J x 19 with 255/40 R 19 tyres*

Brake callipers, painted black

with S7 logo at front

Audi Singleframe

radiator grille in platinum grey with horizontal double chrome struts and S7 emblem

Front bumper

in a distinctive sporty design with honeycomb-structure air intake grilles and double chrome struts; includes aluminium-look blade

Exterior mirror housings

in aluminium look

Side sill trims

Diffuser insert, rear

in platinum grey, edged with blade in aluminium look

Exhaust tailpipes

dual-branch design with 2 oval chrome trims on both left and right

Model name/logo

- S7 emblem in the Audi Singleframe, on the luggage compartment lid and on the vehicle key
- V8 T logo on the front wings

Can also be supplied without the model name/logo on the rear on request

Door sill trims with aluminium inlays with S7 logo

Pedals and footrest in stainless steel

Instrument cluster

with grey dials, white needles and S7 logo in the rev counter; dynamic ready-check feature

Driver information system with colour display

Multifunction sport leather steering wheel in 3-spoke design with shift paddles in aluminium look

with S7 emblem and S-specific stitching

Selector lever knob in aluminium look

with S7 emblem

Engine start-stop button

with red ring

S sport seats, front

S sport seats in the rear

2 individual seats in the rear with shaped seat side bolsters and integrated head restraints, visually matched to the front seats

Seat upholstery in Alcantara/leather, black or lunar silver

with S7 embossing on the front-seat backrests

Inlays

Matt brushed aluminium

Floor mats, front and rear

4-zone deluxe automatic air conditioning

MMI® radio plus

Bluetooth interface

Audi sound system

Storage package

Through-loading facility

Anti-theft alarm

quattro® permanent all-wheel drive

adaptive air suspension – sport

with S7-specific tuning

Audi cylinder on demand

Active Noise Cancellation

The Active Noise Cancellation system can compensate noises from individual frequencies depending on the engine speeds.

S7-specific optional equipment (extract)

Paint finish in the special colour Sepang blue, pearl effect

Cast aluminium wheels in 5-parallel-spoke star design (S design)

size 9 J x 20 with 265/35 R 20 tyres*

Cast aluminium winter wheels in 5-parallel-spoke star design (S design)

size 9 J x 20 with 265/35 R 20 tyres*, cannot be fitted with snow chains, permissible top speed 240 km/h

Sport exhaust system

for an even greater sound experience; 4-branch design, 2 tailpipes each left and right with high-gloss black trims

Seat upholstery

for S sport seats in Valcona leather, black or lunar silver, each with contrasting stitching and S7 embossing on the front-seat backrests; for customised contour seats in Valcona leather, black or flint grey, without S7 embossing on the front-seat backrests

Inlays

Carbon Atlas

Audi design selection Arras red

with inlays in carbon twill, red

quattro® with sport differential

with S7-specific tuning

Dynamic steering

with S7-specific tuning

*You will find specifications on the technical characteristics of tyres on page 101.

There's a sign for maximum efficiency at Audi. The Audi A7 Sportback ultra model – the most sustainable TDI® model in the range.

Technologies and measures for reducing consumption and emissions without any reduction in driving enjoyment – that's what Audi ultra stands for. Standard in every Audi model. The long-term aim: completely emission-free mobility. To achieve this, we are systematically continuing our development work. On more and more efficient drive technologies, for example. Such as our economical diesel engines. We award the most sustainable of these with the ultra emblem on the rear of the model, which announces: maximum efficiency ahead. Thanks to a CO₂ emission value that for the Audi A7 Sportback ultra TDI model is 122 g/km (combined). And without having to give up the dynamics typical of Audi. Experience the Audi A7 Sportback ultra model – a vehicle that redefines efficient driving.



ultra

The image features a central, metallic, three-dimensional Audi 'ultra' emblem. The emblem is a dark grey, rectangular block with rounded ends and a slight curve, giving it a sense of depth. The word 'ultra' is embossed on its front face in a clean, sans-serif font. The emblem is set against a background of several horizontal, parallel lines that create a sense of motion and depth. These lines are in shades of light grey and red, with some appearing as soft, glowing bands. The overall composition is clean and modern, emphasizing the 'ultra' branding.



The **3.0 litre TDI ultra engine** with 160 kW has the following CO₂ emission values in the combined driving cycle: 122 g/km

The **3.0 TDI ultra model in the A7 Sportback is equipped with the following as standard:**

6-cylinder diesel engine
with common rail injection system and turbocharging

S tronic® 7-speed dual-clutch transmission
with minimised internal friction and highly efficient oil supply

Recuperation and start-stop system

Exhaust aftertreatment system
with AdBlue® additive

Driver information system
with gear and efficiency displays

Audi drive select
with efficiency mode

The model-specific standard and optional equipment can be found in the index from page 104 onwards. The illustration shows the Audi A7 Sportback 3.0 TDI ultra. The fuel consumption and CO₂ emission figures as well as the efficiency class can be found on page 99.

The right driving force for every personality.

No matter which Audi engine you choose, they all have high compression ratios, highly efficient combustion and outstanding efficiency. In short, they deliver more power whilst using less fuel and producing fewer emissions.





3.0 TDI

TDI®

Audi TDI engines: high torque output over the entire engine speed range – with constant power build-up. They are renowned for being fuel-efficient and for reducing emissions. The 3.0 TDI quattro, for example, has a power output of 235 kW. In the Audi A7 Sportback, it produces a top speed of 250 km/h and accelerates from 0 to 100 km/h in 5.2 seconds. All TDI engines comply with the EU6 emission standard.

- A7 Sportback 3.0 TDI ultra (160 kW)
- A7 Sportback 3.0 TDI clean diesel quattro (160 kW)
- A7 Sportback 3.0 TDI clean diesel quattro (200 kW)
- A7 Sportback 3.0 TDI clean diesel quattro (235 kW)

The fuel consumption and CO₂ emission figures as well as the efficiency classes can be found from page 98 onwards.



4.0 TFSI with Audi cylinder on demand technology

TFSI®

The Audi TFSI engines offer outstanding efficiency and improved performance whilst at the same time retaining their dynamism. The 4.0 TFSI quattro with 331 kW in the Audi A7 Sportback, for example – from 0 to 100 km/h in 4.6 seconds. All TFSI engines comply with the EU6 emission standard.

- A7 Sportback 3.0 TFSI quattro (245 kW)
- S7 Sportback 4.0 TFSI quattro (331 kW)



2.8 FSI

FSI®

The Audi FSI engine: more power and torque as well as lower consumption – thanks to the two-stage valve control provided by the Audi valvelift system (AVS). In conjunction with the S tronic 7-speed dual-clutch transmission and quattro permanent all-wheel drive, the 2.8 FSI accelerates from 0 to 100 km/h in 8.3 seconds.

- A7 Sportback 2.8 FSI quattro (162 kW)

Remaining faithful to the sporty line: the S line packages.

The S line packages emphasise the sporty character of your Audi A7 Sportback. Accentuate the dynamic body line, lend the interior even more expression or give the suspension even sportier definition for enhanced driving dynamics. And make a true athlete of your Audi.



S line exterior package

Bumpers, front and rear, side radiator grilles, side sill trims and diffuser insert
in a striking, sporty design

Diffuser insert
painted in platinum grey

Door sill trims
with S line logo; in conjunction with ambient lighting, door sill trims illuminated and without S line logo

S line emblem
on the front wings

Paint finish in all standard/optional equipment colours and additionally in the special colours Daytona grey, pearl effect and Misano red, pearl effect.

The fuel consumption and CO₂ emission figures as well as the efficiency classes can be found from page 98 onwards.



S line sport package

The S line sport package includes the following equipment items:

Audi Sport cast aluminium wheels in 7-twin-spoke design
size 9 J x 19 with 255/40 R 19 tyres*.
From quattro GmbH

S line sport suspension
with more dynamic suspension tuning and vehicle lowered by 20 mm compared with dynamic suspension

Door sill trims
with S line logo; in conjunction with ambient lighting, door sill trims illuminated and without S line logo

S line emblem
on the front wings

Interior, dashboard and headlining
in black, with contrasting stitching on sport leather steering wheel and selector lever gaiter; for perforated Alcantara/leather additionally with contrasting stitching on seat upholstery, armrests in the door trims and centre armrest, front; lower part of centre console in leather

Floor mats, front
in black, in conjunction with Alcantara/leather or Valcona leather, lunar silver with piping in a contrasting colour

Sport seats, front
including electric lumbar support

S line seat upholstery in perforated Alcantara/leather, black
with S line embossing on the front-seat backrests

S line multifunction sport leather steering wheel in 3-spoke design
steering wheel grips in perforated leather

Selector lever knob
in perforated black leather

S line inlays
in matt brushed aluminium

Pedals and footrest in stainless steel

Optionally available:

further 19-inch or larger wheels

adaptive air suspension

S sport seats, front
including S sport seats in the rear

S line seat upholstery in Valcona leather, black or lunar silver
with S line embossing on the front-seat backrests

S line multifunction sport leather steering wheel in 3-spoke design with shift paddles
optionally heated; in black leather (steering wheel grips in perforated leather) and with S line emblem

S line inlays
in piano finish, black; fine grain ash, natural brown; Beaufort walnut or aluminium/Beaufort, black

Paint finish in all standard/optional equipment colours and additionally in the special colour Daytona grey, pearl effect

*You will find specifications on the technical characteristics of tyres on page 101.

As unmistakable as your own standards: the Audi design selection.

The Audi design selection offers you an aesthetic pre-selection of special materials and colours for the interior. The fine leather upholstery and trim in Arras red with attractive contrasting stitching give the interior an exclusive ambience.



The fuel consumption and CO₂ emission figures as well as the efficiency classes can be found from page 98 onwards.



**Audi design selection Arras red
(S7 Sportback)**

The Audi design selection Arras red includes the following equipment items:

- S sport seats, front with S7 embossing on the backrests
- seat centre panels with diamond pattern, seat side bolsters, head restraints, door trim inserts, door armrests and centre armrest, front in Valcona leather, Arras red with contrasting stitching
- door trims and lower part of centre console in Alcantara, black
- inlays in carbon twill, red
- floor mats in black
- dashboard and steering wheel in black

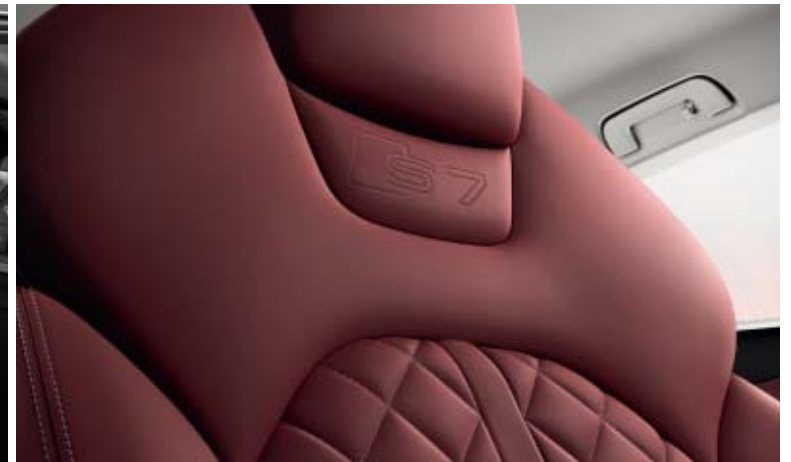

Your personality. Your Audi. The Audi exclusive line.

Every Audi – custom-built for you. With the Audi exclusive line we are offering you the chance to tailor your car. Selected décors and materials are combined into a harmonious whole on the interior. So you can emphasise your own particular style with elegance.



Audi exclusive line is from quattro GmbH.

Audi exclusive line

Customised contour seats, front

including memory function; optionally with seat ventilation, front

Seat upholstery

seat side bolsters and head restraints in Valcona leather, alabaster white with contrasting stitching in powder beige; seat centre panels in perforated leather (with Audi exclusive line-specific perforation) in alabaster white with accordion pleat in powder beige; backrest covers and seat attachments to match in alabaster white

Black interior

headlining in cloth, black

Centre armrest, front

in leather, alabaster white with contrasting stitching in powder beige

Door trims

door trim inserts in leather, alabaster white; leather-covered armrests in the doors in alabaster white with contrasting stitching in powder beige

Inlays

eucalyptus, natural

Floor mats

in black with piping and contrasting stitching in alabaster white

Door sill trims

with Audi exclusive line logo; door sill trims illuminated in combination with ambient lighting

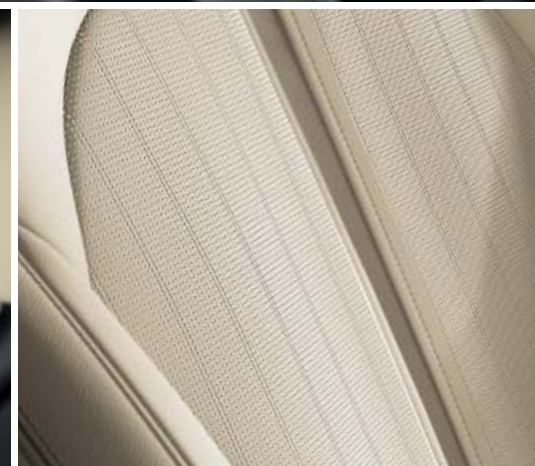

You have an exclusive character. So why shouldn't your Audi have one too?

That the Audi exclusive range aspires to exclusivity is already evident from its name. Selected décors and coloured leather can be combined with customised paint finishes from the large selection of Audi exclusive colours to suit your own personal preferences. So you can highlight your car's exceptional character to even better advantage. Your Audi partner and the Audi exclusive Studio of the Audi Forum Neckarsulm await your wishes.





Audi A7 Sportback in Audi exclusive customised paint finish classic red, pearl effect with Audi exclusive black gloss package

Audi Sport cast aluminium wheels in 5-arm rotor design

Audi exclusive leather upholstery and trim (package 2) in Valcona leather in cloudy grey with contrasting stitching and piping in classic red

Audi exclusive extended leather package in classic red with contrasting stitching in cloudy grey and Audi exclusive leather package including airbag cover

Audi exclusive leather controls in classic red with contrasting stitching in cloudy grey

Leather-covered seat trim in cloudy grey with contrasting stitching in classic red

Audi exclusive seat belts in classic red

Audi exclusive carpet and floor mats in cloudy grey with leather piping in classic red

Inlays in aluminium/Beaufort, black



| Solid paint finishes



Ibis white

| Metallic paint finishes



Glacier white, metallic



Tornado grey, metallic



Havana black, metallic

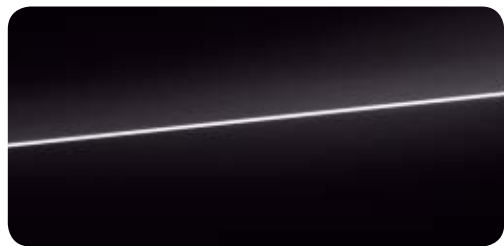

Brilliant black



Floret silver, metallic



Oolong grey, metallic



Mythos black, metallic



Cuvée silver, metallic

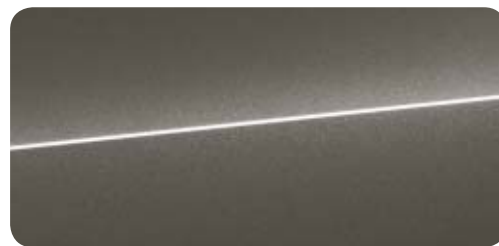

Dakota grey, metallic



Moonlight blue, metallic

| Pearl effect paint finishes

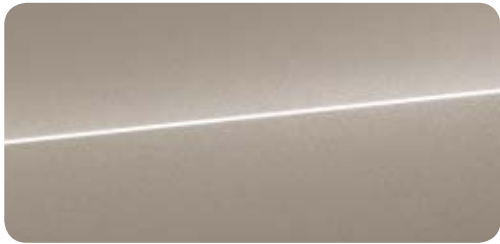

Carat beige, metallic



Misano red, pearl effect



Sepang blue, pearl effect



Audi exclusive customised paint finishes
From quattro GmbH

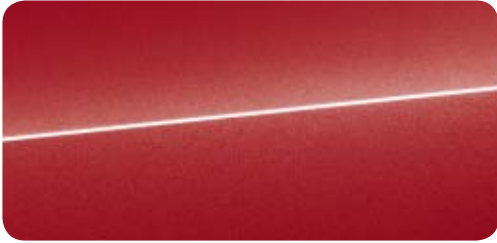

Garnet red, pearl effect

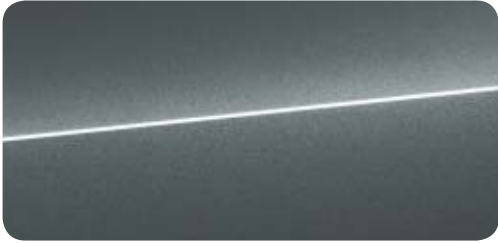

Daytona grey, pearl effect

| Summer wheels



Forged aluminium wheels in 6-arm design
size 8 J x 17 with 235/55 R 17 tyres¹



Cast aluminium wheels in 5-arm Y design
size 8.5 J x 19 with 255/40 R 19 tyres¹



Audi Sport cast aluminium wheels in 7-twin-spoke design³
size 9 J x 19 with 255/40 R 19 tyres¹



Forged aluminium wheels in 5-spoke W design
size 9 J x 20 with 265/35 R 20 tyres¹



Cast aluminium wheels in 7-arm dynamic design
size 8.5 J x 18 with 255/45 R 18 tyres¹



Cast aluminium wheels in 5-V-spoke design
size 8.5 J x 19 with 255/40 R 19 tyres¹



Cast aluminium wheels in 10-spoke design
size 8.5 J x 19 with 255/40 R 19 tyres¹,
optionally available with run-flat tyres



Forged aluminium wheels in 5-spoke W design, contrasting grey, partly polished²
size 9 J x 20 with 265/35 R 20 tyres¹



Cast aluminium wheels in 5-parallel-spoke design (S design)
size 8.5 J x 19 with 255/40 R 19 tyres¹.
Only available for S7 Sportback



Audi Sport cast aluminium wheels in 5-V-spoke design in matt titanium look, gloss turned finish^{2,3}
size 9 J x 19 with 255/40 R 19 tyres¹



Cast aluminium wheels in 5-parallel-spoke star design (S design)
size 9 J x 20 with 265/35 R 20 tyres¹.
Only available for S7 Sportback



Audi Sport cast aluminium wheels in 5-twin-spoke design³
size 9 J x 20 with 265/35 R 20 tyres¹

| Winter wheels



Audi Sport cast aluminium wheels in 5-twin-spoke design in matt titanium look, gloss turned finish^{2,3}
size 9 J x 20 with 265/35 R 20 tyres¹



Audi Sport cast aluminium wheels in 10-Y-spoke design³
size 9 J x 20 with 265/35 R 20 tyres¹



Forged aluminium winter wheels in 6-arm design
size 7 J x 17 with 235/55 R 17 tyres¹, can be fitted with snow chains, permissible top speed 210 km/h



Audi Sport cast aluminium wheels in 5-spoke blade design³
size 9 J x 20 with 265/35 R 20 tyres¹



Audi Sport cast aluminium wheels in 5-arm rotor design
size 9 J x 21 with 275/30 R 21 tyres¹



Cast aluminium winter wheels in 10-spoke design
size 8 J x 19 with 235/45 R 19 tyres¹, can be fitted with snow chains, permissible top speed 240 km/h



Audi Sport cast aluminium wheels in 5-spoke blade design in matt titanium look, gloss turned finish^{2,3}
size 9 J x 20 with 265/35 R 20 tyres¹



Audi Sport cast aluminium wheels in 5-arm rotor design in matt titanium look, gloss turned finish^{2,3}
size 9 J x 21 with 275/30 R 21 tyres¹



Cast aluminium winter wheels in 5-parallel-spoke star design (S design)
size 9 J x 20 with 265/35 R 20 tyres¹, cannot be fitted with snow chains, permissible top speed 240 km/h. Only available for S7 Sportback

¹You will find specifications on the technical characteristics of tyres on page 101. ²Please note the special information relating to wheels on page 100. ³From quattro GmbH.

Premium quality you can rely on.

You have a special place in your Audi. Exclusive comfort can be felt on the front and rear seats: thanks to high-quality materials and first-class workmanship. Regardless of which seat upholstery you choose, or whether you prefer the customised contour seats or sport seats or S sport seats with stable lateral support for dynamic driving: you're sitting in the right place.



Standard seats, front 1

The illustration shows standard seat, front, in Milano leather, flint grey without seat ventilation.



Customised contour seats, front 2

including memory function for driver and front-passenger seat as well as exterior mirrors and steering wheel. The illustration shows customised contour seat, front, in Valcona leather, flint grey with seat ventilation.



Sport seats, front 3

The illustration shows sport seat, front, in Valcona leather, flint grey.



S sport seats, front 4

including memory function for driver and front-passenger seat as well as exterior mirrors and steering wheel; rear seats with shaped seat contours, visually matched to the front seats. The illustration shows S sport seat, front, in Valcona leather, black, with contrasting stitching.

Valcona leather upholstery and trim

high-quality leather that contributes to the elegant charisma of the interior. The low use of lacquer allows the material to breathe whilst the non-grained surface underlines the sophisticated character. Tanned without the use of chromium, dyed through and treated with non-fading colour pigments.

For customised contour seats, front without seat ventilation:

seat centre panels, seat side bolsters, head restraints, door trim inserts and centre armrest, front, in Valcona leather; lower part of centre console in leather

For customised contour seats, front with seat ventilation:

seat centre panels of the front seats and non-ventilated seat centre panels of both outer rear seats in perforated Valcona leather; seat side bolsters, centre rear seat (optional), head restraints, door trim inserts and centre armrest, front, in Valcona leather; lower part of centre console in leather

For sport seats, front:

seat centre panels, seat side bolsters, head restraints, door trim inserts and centre armrest, front, in Valcona leather; lower part of centre console in leather

For S sport seats, front:

seat centre panels, seat side bolsters, head restraint centre panels, armrests in the doors, door trim inserts and centre armrest, front, in Valcona leather; lower part of centre console in leather

Audi exclusive leather upholstery and trim (package 1) in Valcona leather³

seat centre panels, seat side bolsters, head restraints, door trim inserts and centre armrest, front, in Valcona leather; lower part of centre console in leather. Individual choice of colour for the leather and the stitching from the range of Audi exclusive colours

Audi exclusive leather upholstery and trim (package 2) in Valcona leather³

in addition to package 1: leather-covered armrests in the door trims and backrest covers. Individual choice of colour for the leather and the stitching from the range of Audi exclusive colours. Seat attachments matched to the colour of the leather

Audi exclusive leather upholstery and trim (package 1) in Alcantara/Valcona leather³

seat centre panels and door trim inserts in Alcantara; seat side bolsters, head restraints and centre armrest, front, in Valcona leather; lower part of centre console in leather. Individual choice of colour for the Alcantara, the leather and the stitching from the range of Audi exclusive colours

| Cloth**Horizon cloth, black****| Alcantara/leather****1 Alcantara/leather, black****3 4****Alcantara/leather, flint grey****3****Alcantara/leather, lunar silver****4**

Only available for S7 Sportback

**Perforated Alcantara/leather, black****3**

Only available in conjunction with S line sport package

| Part-leather



Part-leather, black



1 Part-leather, black perforated¹



Part-leather, flint grey

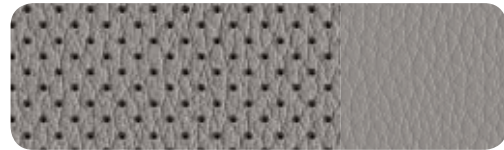

1 Part-leather, flint grey perforated¹



Part-leather, Atlas beige



1 Part-leather, Atlas beige perforated¹



Part-leather, nougat brown



1 Part-leather, nougat brown perforated¹

| Audi design selection



1 Valcona leather, Arras red with diamond pattern and contrasting stitching. Only available for S7 Sportback

| Audi exclusive line

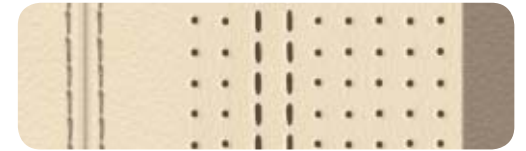

4 Valcona leather, alabaster white³ perforated

| Audi exclusive



Audi exclusive leather upholstery and trim² 1 2 3 4 individual choice of colour for leather/stitching/piping

| Seat variants

- 1 Standard seats, front
- 2 Customised contour seats, front
- 3 Sport seats, front
- 4 S sport seats, front

¹ Only available in conjunction with seat ventilation, front. ² For S7 Sportback with contrasting stitching; for A7 Sportback only in conjunction with S line sport package and without contrasting stitching. ³ From quattro GmbH.

| Leather packages

Leather-covered armrests in the door trims

Leather package

armrest in the doors, lower part of centre console and door pull handles in fine Nappa leather

Leather package including airbag cover*

armrests in the door trims and door pull handle in leather; airbag cover on the steering wheel also in black leather; leather trim for the lower part of centre console, if not already included with the selected equipment

Audi exclusive leather package including airbag cover*

leather trim the same as leather package including airbag cover. Individual choice of colour for the leather and the stitching from the range of Audi exclusive colours. Lower part of centre console also leather-covered, if not already included in the selected equipment

Audi exclusive extended leather package*

dashboard underside including glove compartment and storage on the driver's side, armrests in the door trims, centre console, as well as lower part of centre console in leather. Individual choice of colour for the leather and the stitching from the range of Audi exclusive colours. Steering wheel airbag cover in black leather

Audi exclusive piping for customised contour seats*

Individual choice of colour for the piping from the range of Audi exclusive colours. Can only be ordered in conjunction with Audi exclusive Valcona leather upholstery and trim package 1 or 2

Audi exclusive leather-covered seat trim*

for customised contour seats, front with memory function, electrically adjustable: seat side trims and front trims in fine Nappa leather.

For sport seats, front and S sport seats, front: seat side trims and trims of the extendable thigh support in fine Nappa leather; seat side trims with stitching, switches and handles for seat adjustment in black (not leather-covered).

Individual choice of colour for the leather and the stitching from the range of Audi exclusive colours

| Seating comfort

Front seats, electrically adjustable, including memory function for the driver seat with electric adjustment of seat height, fore/aft position, seat and backrest angle; electric 4-way lumbar support; 2 presets for the electrically adjustable driver seat and exterior mirrors

Seat heating, front

heats the seat and backrest centre panels, for leather upholstery and trim and sport seats also heats the seat side bolsters; individually adjustable in several stages for driver and front-passenger side

Seat heating, front and rear

functions as for seat heating, front, also for the outer rear seats, can be adjusted separately in several stages

Seat ventilation, front

Using a fan for standard seats or by drawing in air for customised contour seats, the system ensures a pleasant seating climate even at high ambient temperatures; seat ventilation for the seat and backrest centre panels as well as the thigh support for the driver and front-passenger seats (adjustable in 3 stages); automatic heating by seat heating to prevent cold seats. With seat ventilation, front, the leather on the front and outer rear seats is perforated.



Massage function, front

massages the muscles of the driver and front passenger using 10 pneumatic cushions; 5 different programs (Wave, Tapping, Stretch, Back, Shoulder) and choice of 5 levels of intensity via multifunction switches on the seat and the optional MMI; display in MMI

| Rear seats**Rear seat system**

2 seats; visually matched to the front seats; 2 L-shaped rear head restraints, height manually adjustable; rear seat backrest can be split-folded 40 : 60 or fully; including fold-out centre armrest with storage compartment and 2 cup holders

S sport seats in the rear

2 individual seats in the rear with shaped seat side bolsters and integrated head restraints, visually matched to the front seats; including storage tray between the outer rear seats with 2 separate storage compartments; rear seat backrest can be split-folded 40 : 60 or fully; including fold-out centre armrest with storage compartment

**Rear seat system 2+1**

shaped outer rear seats, visually matched to the front seats, and an additional seating possibility in the centre; 3 L-shaped rear head restraints, height manually adjustable; rear seat backrest can be split-folded 40 : 60 or fully; including fold-out centre armrest with storage compartment and 2 cup holders

| Headlining**Headlining in cloth, black**

only available in conjunction with black dashboard

Headlining in Alcantara, black*

headlining, upper pillar trim, rear parcel shelf and sun visors in Alcantara, black, stitching in black

Headlining in Alcantara, black with coloured Audi exclusive stitching*

headlining, upper pillar trim, rear parcel shelf and sun visors in Alcantara, black. Individual choice of colour for the stitching from the range of Audi exclusive colours

Experience fascination. Down to the last detail.

Exclusive ambience is a question of style. Your style. A style you can refine right down to the last detail. Create tangible accents with high-quality Audi inlays. Take pleasure in smooth wood that radiates a natural warmth. Experience the fascination of open-pore wood whose exclusivity you can literally feel. Or make a personal statement with combinations of fine woods and aluminium trim – and allow your own personal taste to determine the character.



| Inlays



Satin finish, silver-grey
for interior equipment in flint grey and black



Satin finish, silver-beige
for interior equipment in Atlas beige and nougat brown

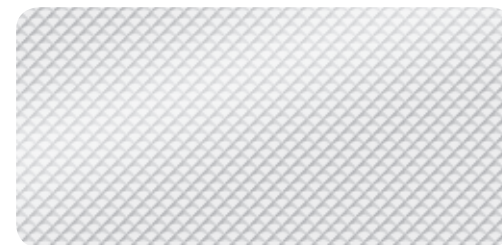

Aluminium delta, silver



Matt brushed aluminium



Piano finish, black*

surrounds for the all-round inlay, door trims and centre console in aluminium look



Eucalyptus, natural

surrounds for the all-round inlay, door trims and centre console in aluminium look. Only available in conjunction with Audi exclusive line



Audi exclusive wood inlays*

surrounds for the all-round inlay, door trims and centre console in aluminium look

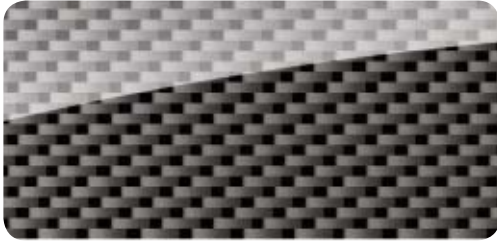

Carbon Atlas

surrounds for the all-round inlay, door trims and centre console in aluminium look



Fine grain ash, natural brown

surrounds for the all-round inlay, door trims and centre console in aluminium look



Beaufort walnut

surrounds for the all-round inlay, door trims and centre console in aluminium look

Inlays

full-surface for the dashboard, door trims, centre console and all-round inlay

Audi exclusive wood inlays*

available in fine grain ash, nougat; oak, sepia; fine grain myrtle, nutmeg; vavona, bronze; modrone, gold; tamo ash, natural dark brown



Carbon twill, red

surrounds for the all-round inlay, door trims and centre console in aluminium look. Only available in conjunction with Audi design selection Arras red



Walnut, dark brown

surrounds for the all-round inlay, door trims and centre console in aluminium look

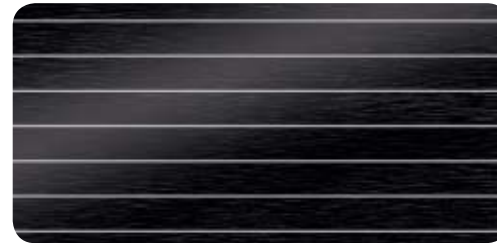

Aluminium/Beaufort, black*

surrounds for the all-round inlay, door trims and centre console in aluminium look

| Headlights



LED headlights

allow precise, near-daylight illumination of the road; combines LED dipped beam, high beam, daytime running lights, motorway light, indicators and static turning light as well as an all-weather light; including headlight cleaning system; motorway light which automatically increases headlight range from a speed of approximately 110 km/h; all-weather light to reduce the risk of the driver being dazzled when visibility is poor; striking light pattern in day and night design configurations; low energy consumption and long service life



Audi Matrix LED headlights

This innovative technology combines a camera system with LED light sources and precision optics for highly adaptive light distribution. The system blanks out light that would otherwise shine directly on oncoming vehicles or vehicles in front but continues to fully illuminate all the other areas in between and alongside. The front lighting thus adapts dynamically, providing the driver with a much wider visual range. The conventional division between dipped and high beam is dispensed with. Familiar convenience functions such as the static turning light, all-weather light, junction light, travel mode, which uses GPS data to switch between right- and left-hand drive modes are integrated into the LED technology. The LEDs of the Audi Matrix LED headlights also perform the dynamic cornering light functions. Using vehicle support based on navigation data, it starts responding shortly before the steering wheel is turned. The marking light cooperates with the optional night vision assistant. If pedestrians are detected, individual LEDs flash briefly three times in succession to mark out the pedestrians clearly from their surroundings. Distinctive features include the crisp lighting pattern, the LED daytime running lights and the dynamic indicators in the headlights and rear lights.



LED rear lights with dynamic indicators

brake lights, tail lights, rear fog lights, indicators and rear number plate lights in low-energy LED technology; with reversing lights in white; high-mounted 3rd brake light in the rear window; dynamic and quickly recognisable lighting pattern: the segments of the LED light band are illuminated in turn within milliseconds, creating a pulse of light that runs outwards in the direction in which the car is turning. When operated, the indicators send a distinctive signal to other road users

High-beam assist

improves the driver's visibility and ensures a more relaxed drive thanks to the extra comfort and convenience. Depending on the traffic situation, the high beam is automatically switched on or off. Working within system limits, automatically detects the headlights of oncoming traffic, the rear lights of other road users and light sources in built-up areas. In conjunction with the optional night vision assistant, the connected vehicle functions allow the marking light for detected pedestrians for enhanced safety when driving at night.

| Interior lighting



Ambient lighting

with integrated eyewear compartment in the roof module; additional to the interior and exterior lighting package, anti-glare illumination for the passenger compartment in LED technology:

- interior lighting, front and rear, including reading lights
- illuminated vanity mirror
- ambient lighting for centre console
- lighting for door pockets
- illuminated door sill trims (with the optional S line packages the door sill trims are without the S line logo)

Configured via MMI

Interior and exterior lighting package

Interior lighting: ambient light for door inner panels to help occupants better orient themselves, as well as front and rear entrance lighting in LED technology; illuminated vent controls

Exterior lighting: courtesy lighting on the underside of the door handles and handle recess lighting in LED technology; active door reflectors (light bulbs)

| Exterior design

**Exhaust tailpipes**

dual-branch design with 1 tailpipe each left and right with chrome-plated trims

Model name/logo

A7 logo, ultra emblem (for A7 3.0 TDI ultra 160 kW) as well as TDI, FSI or TFSI logo on the luggage compartment lid, can be omitted on request

Rear spoiler

integrated in the luggage compartment lid; automatically extends at 130 km/h, retracts at 80 km/h; can also be controlled manually using a button in the centre console

Gloss package

window slot trims in anodised aluminium, external B-pillar trim in high-gloss black

Audi exclusive black gloss package*

creates black styling accents around the Audi Singleframe, the front bumper and the trim strips on the side windows

| Interior design

**Door sill trims with aluminium inlays****Aluminium-look interior**

on light switches, air conditioning, MMI rotary/push-button control, vents and around the selector lever gaiter

Audi exclusive floor mats*

individual choice of colour for the floor mats, the leather piping and the stitching from the range of Audi exclusive colours

Audi exclusive carpet and floor mats*

individual choice of colour for the carpet, the floor mats, the leather piping and the stitching from the range of Audi exclusive colours

| Steering wheels/controls

**Multifunction sport leather steering wheel in 3-spoke design with shift paddles**

same functions as multifunction sport leather steering wheel in 3-spoke design, including shift paddles for changing gear manually with automatic transmission

Multifunction sport leather steering wheel in 3-spoke design

for operating the available infotainment features; adjustable in height and reach; with full-size airbag; colour-coordinated with the selected colour for the top side of the dashboard

Multifunction sport leather steering wheel in 3-spoke design with shift paddles, heated

same functions as multifunction sport leather steering wheel in 3-spoke design with shift paddles, steering wheel rim additionally heated

**Multifunction leather steering wheel in 4-spoke design with shift paddles**

same functions as multifunction leather steering wheel in 4-spoke design, including shift paddles for changing gear manually with automatic transmission

Multifunction leather steering wheel in 4-spoke design

for operating the available infotainment features; adjustable in height and reach; with full-size airbag; colour-coordinated with the selected colour for the top side of the dashboard

Multifunction leather steering wheel in 4-spoke design, heated

same functions as multifunction leather steering wheel in 4-spoke design, additionally heated

Electric steering wheel adjustment

adjustable in height and reach, with automatic entry and exit function; additionally with memory function if front seats, electrically adjustable are ordered

| Steering wheels/controls



Audi exclusive steering wheel rim with wooden segments^{1,2}

for multifunction leather steering wheel in 4-spoke design with shift paddles; customised with Audi exclusive wood and leather (not tamo ash, natural dark brown); individual choice of stitching in various Audi exclusive colours

Steering wheel rim with wooden segments^{1,2}

for multifunction leather steering wheel in 4-spoke design with shift paddles, available in walnut, dark brown

Audi exclusive steering wheel rim in leather²

leather covering for the steering wheel rim available in all Audi exclusive colours; individual choice of colour for stitching in various Audi exclusive colours with specific Audi exclusive seam detail

Audi exclusive leather controls²

leather covering of the steering wheel rim, selector lever knob and gaiter available in all Audi exclusive colours; individual choice of colour for stitching in various Audi exclusive colours; stitching on the steering wheel rim with specific Audi exclusive seam detail

Selector lever knob in leather

colour-coordinated with the selected vehicle interior colour and to match the top side of the dashboard

| Mirrors

Exterior mirrors with integrated LED indicator electrically adjustable and heated, convex, flat or aspherical mirror glass; additionally with memory function if front seats, electrically adjustable are ordered; body-coloured housing

Also optionally:

electrically folding

including automatic kerb-side function for the exterior mirror on the passenger side

automatically dimming on both sides

including automatic kerb-side function for the exterior mirror on the passenger side

electrically folding and automatically dimming on both sides

including automatic kerb-side function for the exterior mirror on the passenger side

The automatic kerb-side function tilts the exterior mirror on the passenger side downwards when reverse gear is selected, giving the driver a better view of the kerb.

| Roof system



Slide-and-tilt glass sunroof

electric, with tinted single-glazed safety glass and infinitely adjustable sun screen; includes integrated wind deflector; convenience closing/opening from outside with the vehicle key

| Glazing

**Dark-tinted windows (privacy glazing)**

dark-tinted rear window, rear door windows and rear side windows

Heat-insulating glass

tinted green; windscreen and front side windows in acoustic glass for improved exterior noise insulation; rear window heated, with timer

Insulating/acoustic glass

provides improved exterior noise insulation and theft protection thanks to the 2 panes of glass bonded together by a plastic film. An additional reflective coating reduces the build-up of heat in the interior. Windscreen with viewing window for toll collection devices

Insulating/acoustic glass and dark-tinted windows (privacy glazing)

windscreen and front door windows in insulating/acoustic glass; dark-tinted rear window, rear door windows and rear side windows; windscreen with viewing window for toll collection devices

Sun screen

in the luggage compartment cover, extendible, in black cloth

| Climate control

**Deluxe automatic air conditioning**

electronically regulates the air temperature, flow rate and distribution, separate temperature distribution for driver and front passenger; with ventilation via the defroster nozzles for the windscreen and side windows; automatic recirculation mode, sunlight-dependent control and combined fine particulate filter; with humidity sensor and key-coded setting; ventilation in the rear via the centre console

**4-zone deluxe automatic air conditioning**

in addition to the deluxe automatic air conditioning: air-conditioning controls, front with digital display, additional air-conditioning controls with digital display for climate control in the rear with separately adjustable temperature and blower settings and air distribution for the right and left-hand sides (rear functions can also be set from the front air-conditioning controls), additional air vents in the B-pillars, automatic recirculation mode by means of air quality sensor, use of residual heat, separate regulation of footwell temperature, ventilated glove compartment. Choice of 3 climates: gentle, medium and intensive

**Auxiliary heating/ventilation**

The auxiliary heating warms up the interior and removes ice from the windows without starting the engine. The auxiliary ventilation system supplies fresh air and reduces the temperature of the interior. Intelligent control function with timer and departure time programming for time- and energy-efficient calculation of heating duration. Separate radio-operated remote control with illuminated display; choice of 2 heating modes: "defrost" (defrosting mode only for the windows), "warm" (warming up mode to additionally preheat the interior)

| Closing systems



Convenience key including sensor-controlled release of the luggage compartment lid

doors and luggage compartment lid can be opened and locked without actuating the key carried with you; doors are unlocked automatically by touching the door handles (all door handles have an aluminium-look trim strip, door handles in body colour in conjunction with Audi exclusive black gloss package), the luggage compartment by operating the handle strip on the luggage compartment lid. Moving your foot (in a kicking motion) below the rear bumper causes the luggage compartment lid to swing open automatically when the vehicle key is recognised. The luggage compartment lid can also be opened separately when the vehicle is locked.

Luggage compartment lid, electrically opening and closing

opening via button on the vehicle key or in the driver's door or the soft touch button in the luggage compartment lid handle; additionally by means of foot gesture (kicking motion) if convenience key with sensor-controlled release of luggage compartment lid is ordered; closing via button on the inside of the luggage compartment lid, the button in the driver's door or the optional convenience key (long press). In conjunction with the convenience key, it is possible to close the luggage compartment lid and simultaneously lock the car via an additional button on the inside of the luggage compartment lid. Including power-assisted closing and programmable luggage compartment lid opening angle

Power-assisted door closing

doors that have not completely closed are pulled into the lock automatically

Garage door opener (HomeLink)

programmable radio-operated remote control with operating buttons integrated into the front roof module, can be used to open many garage doors and exterior gates; allows control of security systems and lighting systems; code identification guidance and setup assistance provided by the optional MMI navigation plus. For further information please contact your Audi partner or visit www.eurohomelink.com.

Anti-theft alarm

monitors doors, bonnet and luggage compartment lid; includes interior monitoring (can be deactivated), tow-away protection via a tilt angle sensor and signal horn independent of the vehicle electrical system; with safe-locking function: prevents the doors from being opened from the inside once the vehicle has been locked with the radio-operated remote control

Preparation for tracking system

preparation for connecting a tracking system (available from Audi Genuine Accessories) that enables a stolen vehicle to be located and tracked

| Storage/transport

Storage compartments

storage compartment in the front and rear door trims, e.g. for bottles up to 1 litre, storage net on the back of the front-seat backrests, storage compartment under the front seats (for standard seats, front); glove compartment on the passenger side, lockable, large, illuminated, with holder for writing utensils; 2 cup holders in the centre console

Storage package

2 cup holders in the centre armrest, rear, luggage compartment net for securing on the lashing points on the luggage compartment floor, additional 12V socket in the rear

Provision for trailer towing hitch

includes fitting for the control units and reinforced engine cooling. The trailer towing hitch for retrofitting is available from Audi Genuine Accessories.

Trailer towing hitch

mechanically swivelling, forged steel sphere bar and ball head; operated via pull button in luggage compartment, control light in luggage compartment and display in instrument cluster to monitor secure attachment of trailer; includes trailer stabilisation function via the Electronic Stabilisation Control (ESC). The integrated swivelling system socket enables continuous operation of electrical equipment in the trailer or caravan during a journey.



Luggage compartment

large-volume, with large through-loading width; includes side net on the right-hand side; 4 lashing points on the luggage compartment floor, with 12V socket in the right-hand side panel trim as well as bag hooks on the left- and right-hand sides of the luggage compartment; luggage compartment cover



Through-loading facility with removable ski/snowboard bag

for the practical transportation of long items, e.g. up to 4 pairs of skis or 2 snowboards; ski/snowboard bag can be removed and secured by a strap

Reversible mat

to cover the luggage compartment, also when the rear-seat backrest is folded down; velour on one side, rubber on the other

Non-smoker version

one storage compartment in the front and an additional 12V socket in the rear instead of the cigarette lighter

MMI®/navigation



Driver information system

displays a host of useful information on a 5-inch TFT monochrome display in the driver's direct field of vision. Attention assist provides a warning in the driver information system and via acoustic signal if it determines that the driver's attention is lapsing. The system is active from around 65 to 200 km/h and can be deactivated. An integrated efficiency program provides consumption data overviews.



Driver information system with colour display

shows the information of the driver information system on a high-resolution 7-inch colour display with an even better overview and readability; additional display of information from the driver assistance systems, the media being used, outside temperature and other display content from the MMI system – if fitted – such as navigation, night vision assistant and telephone menu

| MMI®/navigation



MMI® navigation

- with navigation data (SD card)¹
- electrically extending 6.5-inch colour display with high-quality map representation and numerous detailed display options
- dynamic route guidance with TMC (where available)
- voice control (whole-word input)
- additional arrow display in the driver information system
- MMI radio plus
- CD player and 2 SDHC memory card readers (up to 32 GB), each MP3, WMA and AAC compatible
- Audi music interface for the connection of portable media players such as Apple iPod, Apple iPhone (music functionality) as well as USB storage media and MP3 players (can only be used in conjunction with special Audi Genuine Accessories adapter cables)
- Bluetooth interface for hands-free calls and audio streaming
- Audi sound system



MMI® navigation plus with MMI touch

- navigation system¹ including map updates²
- electrically extending, high-resolution 8-inch colour display
- 3D map display showing many places of interest and city models
- detailed route information: map preview, choice of alternative routes, POIs, lane recommendations, motorway exits, detailed junction maps and much more
- MMI touch: touch-sensitive control panel for quick, intuitive operation, e.g. destination entry by handwriting recognition as well as moving around and zooming on the map
- voice control system with whole-word entry of address in one sentence
- access to smartphone voice control
- driver information system with 7-inch colour display including display of navigation map
- dynamic route guidance with TMCpro (in conjunction with Audi connect: traffic information online), spoken traffic information and display of alternative routes
- vehicle support based on navigation data and speed limit display
- country information: information on valid speed limits, motorway toll sticker requirement, etc. when crossing a border
- myAudi special destinations: import individual point-of-interest (POI) lists into the vehicle via the myAudi portal
- MMI radio plus
- Audi sound system
- flash memory for music (10 GB)
- DVD drive (MP3, WMA, AAC and MPEG-4 compatible) for music CDs and video DVDs
- 2 SDXC card readers
- Audi music interface for the connection of portable media players via USB interface (including power supply/charging function) or Wi-Fi
- Bluetooth interface for hands-free calls and audio streaming
- display of emails and text messages from mobile phone in selected languages plus text-to-speech function³
- use of services supported by Audi connect⁴

| Entertainment

MMI® radio

- MMI operating concept with electrically extending 6.5-inch colour display, separate MMI control panel and car menu
- CD player (MP3 and WMA compatible), AUX-IN connection, USB charging function
- radio with phase diversity
- 8 passive loudspeakers, front and rear, total output 80 watts

MMI® radio plus

- MMI operating concept with electrically extending 6.5-inch colour display, separate MMI control panel and car menu
- driver information system
- CD player and 2 SDHC memory card readers (up to 32 GB), each MP3, WMA and AAC compatible
- Audi music interface for the connection of portable media players such as Apple iPod, Apple iPhone (music functionality) as well as USB storage media and MP3 players (can only be used in conjunction with special Audi Genuine Accessories adapter cables)
- radio with phase diversity, TP memo (automatically saves traffic news when driving)
- voice control
- Bluetooth interface for hands-free calls and audio streaming
- Audi sound system

Digital Audio Broadcasting

in addition to the range of analogue stations, reception of digitally broadcast radio stations⁵ according to DAB standard, including DAB+ and DMB audio; display of information accompanying the programme (e.g. artist and track, if provided by the radio station) as well as additional information in the form of a slide show (e.g. cover and weather)

Digital TV reception

reception of digitally broadcast, uncoded television stations⁵ (in DVB-T and DVB-T2 standard with MPEG-2 or MPEG-4 video coding) as well as DVB-T audio stations; display of information accompanying the programme such as teletext, subtitles and Electronic Programme Guide (EPG); automatic station search; external AV-IN connection via adapter cable; no picture possible when the vehicle is moving

Adapter cable set for Audi music interface

consisting of 2 connecting cables for the connection of Apple iPod/iPhone with dock connection (e.g. iPhone 4) as well as data storage devices/media players⁶ with USB port (type A); other adapter cables are available from Audi Genuine Accessories

Adapter cable set plus for Audi music interface

same features as the adapter cable set for the Audi music interface, plus possibility of cover art display and video functions in connection with Apple iPhone and more recent Apple iPod generations⁶ (depending on the device used)

**Audi sound system**

impressive sound thanks to 6-channel amplifier with a total output of 180 watts and 10 loudspeakers including centre speaker and subwoofer

CD changer

for 6 CDs (MP3 and WMA compatible); shock-resistant location in glove compartment and can be operated via MMI

DVD/CD changer

for 6 DVDs or CDs; supports audio CDs and video DVDs; shock-resistant location in glove compartment and can be operated via MMI

**Bose Surround Sound**

impressive surround sound reproduction thanks to 12-channel amplifier with total output of over 600 watts and 14 loudspeakers, including centre speaker and subwoofer; noise-dependent volume adjustment thanks to Audipilot® and reproduction of 5.1 surround sound in conjunction with MMI navigation plus with MMI touch; powerful and accurate base reproduction, lifelike sound with natural tone and a feeling of space for an outstanding sound experience

**Bang & Olufsen Advanced Sound System**

captivating surround sound reproduction with 15 loudspeakers, including centre speaker and subwoofer, each with its own amplifier channel. The efficient 15-channel DSP all-digital amplifier with 5 integrated ICE-Power amplifiers for woofers and subwoofers has a total output of over 1,200 watts. Reproduction of 5.1 surround sound is possible. Polished loudspeaker covers in aluminium and automatically extending acoustic lenses for excellent sound performance and perspective in any seat; with noise-dependent volume adjustment. Privacy function provided by encapsulated loudspeaker casings which minimise the escape of sound to the outside of the vehicle and provide privacy, for example when making phone calls.

Preparation for Rear Seat Entertainment

includes pre-installation wiring and mounts for the holders in the driver and front-passenger seat backrests. The appropriate Audi Entertainment mobile (9-inch screen with integrated DVD player) and the holder or an Apple iPad™ adapter are available as a plug-and-play unit from Audi Genuine Accessories (see page 97).

¹Navigation data are not available for all countries and regions. For more information, please contact your local Audi partner. ²The map version delivered can be updated with the first 5 updates which are issued at intervals of 6 months. The current navigation data can be downloaded from the myAudi platform at www.audi.com/myaudi and installed in the vehicle via SD card. In conjunction with Audi connect, the update can be carried out online in the vehicle. In addition, it is possible to have the new navigation data installed by an Audi partner at extra cost. ³Provided the mobile phone has the Bluetooth profile MAP (Message Access Profile). Please contact your Audi partner or visit www.audi.com/bluetooth for information on compatible mobile phones. ⁴Requires the optional equipment Audi connect. ⁵Reception depends on local digital network availability. ⁶Please contact your Audi partner or visit www.audi.com/mp3 for information on compatible media players.

| Communication

Audi connect

convenient connection of your vehicle to the internet for the use of Audi connect via an integrated data module with LTE¹/UMTS support. There is a reader for your SIM card in the surround of the MMI navigation plus with MMI touch.

The following services supported by Audi connect are currently available in your model:

Communication

- access to smartphone voice control²
- Wi-Fi hotspot
- text messages^{3,7}
- access to Facebook
- access to Twitter

Mobility & navigation

- map update online⁴
- point-of-interest (POI) search
- traffic information online
- navigation with Google Earth™⁵ and Google Street View™⁵
- destination entry via myAudi or Google Maps™⁵
- picturebook navigation
- flight information
- train information
- fuel prices
- parking information

Infotainment

- weather
- online media streaming⁶
- news online (individual)
- city events
- travel information

In conjunction with the optionally available Audi phone box, Audi connect contains a car phone function via SIM card slot or SAP profile.

Use of the services supported by Audi connect is possible only with the optional MMI navigation plus with MMI touch and Audi connect. You also require a SIM card with data option and with LTE option¹ to use LTE. The services are available only in conjunction with an existing or separate mobile phone contract and only within the range of the respective mobile phone network. Additional costs may be incurred when receiving data packets from the internet, depending on the terms of your mobile phone contract, particularly when used abroad. Because of the high data volumes involved, a data flat rate is strongly recommended.

The availability of the services supported by Audi connect varies from country to country. The Audi connect services are provided for at least one year from vehicle delivery. 24 months after vehicle delivery, the Audi connect services will be extended free of charge once for 12 months. Ask your Audi partner about a subsequent extension of the Audi connect services. Audi connect provides access to Facebook, Google and Twitter services. Permanent availability cannot be guaranteed as this is the responsibility of Facebook and Twitter.

Please visit www.audi.com/connect or contact your Audi partner for more detailed information about Audi connect; contact your mobile services provider for information about contract conditions.



Audi phone box⁷

allows phone calls to be made in the vehicle with improved reception quality and charging by placing the mobile phone in the front centre console; hands-free facility and voice control (phone); low SAR radiation inside the vehicle thanks to connection to vehicle aerial; operation via the radio/navigation systems or the multifunction leather steering wheel; can be charged via USB port. The illustration shows Audi phone box in conjunction with MMI navigation.

Bluetooth interface

allows hands-free calls to be made in the vehicle using the microphone and – depending on the mobile phone compatibility⁷ – Bluetooth audio streaming. Bluetooth-capable mobile phones can be connected to the vehicle via the interface. Part of MMI radio plus, MMI navigation and MMI navigation plus with MMI touch

| Assistance systems



Parking system plus⁸

acoustic and visual parking assistance for the front and rear, assists with parking and manoeuvring. Information shown in the MMI display; measurement is by ultrasonic sensors integrated discreetly in the bumpers; can also be optionally ordered with reversing camera or front and reversing cameras; activated when reverse gear is selected or via a button on the centre console



Park assist with display of surroundings⁸

uses ultrasonic sensors to search for suitable parking spaces along the side of the road and helps the driver to park and exit parking spaces by performing virtually autonomous steering manoeuvres. Calculates the ideal parking path for bay parking spaces and the ideal parking and exiting paths for kerb-side parking spaces. The driver has to accelerate, apply the brakes and monitor the parking process. The display of the surroundings warns the driver of any obstacles at the side of the vehicle, depending on the steering angle. Also optionally available with reversing camera or front and reversing cameras; activated via a button on the centre console



Reversing camera⁸

image of area behind the vehicle shown on the MMI display, with dynamic display modes showing the calculated path based on the steering angle; help lines and guidelines and identification of point at which to apply opposite lock when parallel parking; reversing camera integrated discreetly in the handle strip of the luggage compartment lid; activated when reverse gear is selected or via the button on the centre console

Front and reversing cameras⁸

image of area in front and behind the vehicle shown on the MMI display, for the reversing camera with dynamic display modes showing the calculated path depending on the steering angle; help lines and guidelines and identification of the point at which to apply opposite lock when parallel parking; reversing camera integrated discreetly in the handle strip of the luggage compartment lid; additional display modes for front left/right side and rear left/right side for safe pulling out of tight parking spaces, courtyard entrances or in car parks; activated when reverse gear is selected or via a button on the centre console

Hold assist⁸

holds the vehicle stationary for unlimited periods after stopping in traffic on normal uphill and downhill gradients. The system is activated by push-button and allows the driver to drive away smoothly.

Cruise control⁸

At speeds of from around 30 to 250 km/h, the system keeps the set speed constant provided that engine power and engine braking effect permit it; operated via separate steering column stalk, set speed displayed in the driver information system.

Audi pre sense basic⁸

automatically initiates preventive passenger protection measures when required; these include: belt tensioning, activation of the hazard warning lights and closing of slide-and-tilt glass sunroof (if ordered) and windows; categorises different driving situations through the networking of the various vehicle systems



adaptive cruise control with Stop&Go function including Audi pre sense front⁸

Vehicles ahead are detected with the aid of radar sensors. The distance from the vehicle ahead is kept more or less constant by braking or accelerating (control range 0–250 km/h). Choice of 4 distance levels/driving modes (efficiency, comfort, dynamic and auto). Includes Audi pre sense front: enhanced brake assist function warns of any imminent threat of collision with the vehicle in front. Can initiate partial braking action or boost the driver's braking action if necessary. In addition, maximum braking is initiated at speeds below 30 km/h if there is a danger of collision with a stationary or moving vehicle in order to reduce the speed of the collision or to avoid the collision if possible. adaptive cruise control is operated via a separate steering column stalk. Audi pre sense front can be deactivated via the MMI car menu.

¹Please consult your Audi partner for information on the availability and use of LTE support. ²Requires the optional MMI navigation plus with MMI touch including voice control system and Bluetooth interface as well as a multifunction steering wheel. ³Provided the mobile phone has the Bluetooth profile MAP (Message Access Profile). ⁴The map version delivered can be updated with the first 5 updates which are issued at intervals of 6 months. The current navigation data can be downloaded from the myAudi platform at www.audi.com/myaudi and installed in the vehicle via SD card. In conjunction with Audi connect, the update can be carried out online in the vehicle. In addition, it is possible to have the new navigation data installed by an Audi partner at extra cost. ⁵Google and the Google logo are registered trademarks of Google Inc. ⁶For information on when this feature will be available, please contact your Audi partner. Depends on country-specific availability. To use this feature you will generally require an account with a media streaming provider. Additional costs may be incurred as a result. ⁷Please contact your Audi partner or visit www.audi.com/bluetooth for information on compatible mobile phones. ⁸Please note: The systems work only within system limits. They assist the driver with driving tasks. However, the driver remains responsible for driving the vehicle and is required to be attentive.

| Assistance systems



Audi side assist including Audi pre sense rear¹ warns by means of an LED display on the relevant exterior mirror of any situations assessed as critical for changing lanes. 2 radar sensors record the vehicle approaching at the side from behind and measure the distance and the difference in speed. The lane change assistant provides support in the speed range from around 30 to 250 km/h. To detect a possible rear-end collision, Audi pre sense rear also uses the rear sensors of Audi side assist, in addition to Audi pre sense basic. Activated via a button in the mirror quadrant

Assistance package including Audi pre sense plus¹

- combines the following assistance systems:
- parking system plus
 - Audi active lane assist
 - Audi side assist
 - adaptive cruise control with Stop&Go function
 - Audi pre sense front
 - Audi pre sense rear

The functions mentioned above also include a maximum deceleration function provided by Audi pre sense plus. The systems in the assistance package complement each other and provide mutual assistance. Notes on activation and settings can be found in the description for the respective assistance system.



Audi active lane assist¹ helps you keep in lane by means of gentle steering intervention. The lane compliance assistant is triggered when the driver starts to cross detected lane markings without activating an indicator. The system provides assistance in the speed range from around 60 to 250 km/h. Steering wheel vibration can be adjusted if the driver wants; additional display in the optional head-up display; activated via a button on the indicator steering column stalk.

In conjunction with the optional Audi side assist including Audi pre sense rear, a perceptible steering movement is also made before leaving the lane, if changing lane is rated as particularly critical due to a vehicle approaching from behind. This steering movement is made even if the indicator has been activated but only if both systems are activated and ready.



Head-up display

Information relevant to the driver from assistance systems, navigation instructions and warnings is projected as required onto the windscreen in the driver's direct field of vision. The height-adjustable head-up display provides a multicoloured display with good contrast and minimal distraction from the road.

| Driving dynamics/brakes

**Night vision assistant¹**

assists the driver when driving at night by displaying a thermal image of the surroundings. Persons and larger wild animals are highlighted in yellow in the colour display of the driver information system. If they move or if the system determines from their position that there is a potential risk, the marking changes to red, a warning triangle appears and a warning tone is emitted.

In conjunction with one of the following lighting systems, a highlighted person is also illuminated with 3 successive brief flashes of the headlights (marking light):

- LED headlights in combination with high-beam assist
- Audi Matrix LED headlights

Additional display of the warnings in the optional head-up display; activated via a button next to the light switch

**Camera-based speed limit display^{1, 2}**

recognition and display of speed limits, including temporary speed limit displays; a situational evaluation is carried out when driving in the wet, when there are speed limits for certain times of day, or when towing a trailer³; if a sign has not been recognised by the camera, the speed limit taken from the current navigation data is displayed via Audi connect; additional display in the optional head-up display. The system has purely informative character, there is no intervention and no warning if the displayed speed is exceeded.

**Audi drive select**

different modes – auto, comfort, dynamic, efficiency and individual – allow you to adjust the vehicle's characteristics by adapting the power steering assistance, accelerator and gear changing characteristics and the settings of other optional equipment. The efficiency mode shifts specifically selected systems to a consumption-improved basic setting.

Sport suspension

more direct contact with the road and sportier handling thanks to body being lowered by 10 mm, compared with the standard dynamic suspension, and stiffer spring and damper tuning

S line sport suspension

more dynamic suspension setting and vehicle lowered by 10 mm compared with the sport suspension or by 20 mm compared with the standard dynamic suspension

adaptive air suspension

automatically regulates vehicle ride height and damping by means of electronically controlled air suspension with infinitely variable adaptive damping system on all 4 wheels; includes ride height control and manual lift function; different modes selected via Audi drive select; vehicle ride height lowered by up to 20 mm depending on mode

¹Please note: The systems work only within system limits. They assist the driver with driving tasks. However, the driver remains responsible for driving the vehicle and is required to be attentive. ²Only available for Western Europe. ³Only applies to factory-fitted trailer towing hitches.

| Driving dynamics/brakes



quattro® with sport differential

The electronically controlled sport differential distributes variable amounts of drive force to each wheel and ensures outstanding acceleration performance in corners and stabilises the vehicle's response to load change. It also improves direct steering characteristics and provides more agile handling due to the lower steering effort required.

quattro®

permanent all-wheel drive with self-locking centre differential and asymmetric/dynamic torque distribution, as well as wheel-selective torque control and Electronic Differential Lock (EDL) on all driven wheels; quattro emblem in Audi Singleframe, on the luggage compartment lid and in the dashboard on the passenger side

Dynamic steering

when changing lanes, parking and cornering, for example, this system improves handling and ride comfort by dynamically regulating the steering according to the driving situation; in addition to adaptation of the steering effort, the steering angle (steering ratio) is also adapted; also supports vehicle stabilisation via ESC



Ceramic brake¹

19-inch high-performance brake system with carbon-fibre reinforced ceramic brake discs and brake callipers painted in high-gloss anthracite and featuring the "Audi ceramic" logo; logo at rear on a black design trim; ventilated and perforated brake discs with special cooling channels

S tronic®

The 7-speed, electrohydraulically actuated dual-clutch transmission facilitates faster gear changes with virtually no perceptible break in propulsive power. Including coasting mode in efficiency mode: when the accelerator is released, the drivetrain is opened and the engine automatically switches to idling. In automatic mode, the driver can choose between the programs D (Drive) and S (Sport). The S tronic can be operated manually via the selector lever or the optional shift paddles behind the steering wheel.

tiptronic

8-speed automatic transmission with Dynamic Shift Program (DSP) and sport program; option of manual control via shift paddles on the multifunction leather steering wheel or by nudging the selector lever

| Technology/safety

Body, galvanised

lightweight aluminium hybrid construction; fully galvanised in areas at risk from corrosion, self-supporting, welded to the floor pan, front and rear areas feature defined crumple zones. (12-year guarantee against rust perforation)

Electronic Stabilisation Control (ESC) with electronic axle-differential lock

modifies the drive forces via selective brake intervention, depending on the driving situation. When cornering, the electronic axle-differential lock ensures more precise and more neutral handling with no understeer. Improves traction and dynamic performance when cornering

Recuperation

economises on fuel through brake energy recovery; kinetic energy is converted into usable electrical energy by increasing the generator voltage when the vehicle is coasting or braking and relieving the generator during a subsequent acceleration

Start-stop system

helps to reduce fuel consumption and CO₂ emissions by automatically switching off the engine when the vehicle is stationary, e.g. at traffic lights. The start process is initiated as soon as the foot brake is released. May be deactivated using a switch at any time

Side airbags, rear

to supplement side airbags at the front and head airbag system

Seat belts, crimson red²

Audi exclusive seat belts²

Individual choice of colour for seat belt from the range of Audi exclusive colours.

Audi TDI clean diesel

In addition to the standard equipment with catalytic converter and diesel particulate filter, the exhaust aftertreatment system installed in the models with TDI clean diesel leads to low exhaust emissions and consequently complies with the EU6 emission standard which comes into force in September 2014. This technology significantly reduces nitrogen oxides by injecting small quantities of the biologically degradable additive AdBlue^{®3} into the exhaust flow and breaking it down to nitrogen and water in the nitrogen oxide catalytic converter (DeNOx catalytic converter). Refill the separate AdBlue tank as indicated by the information in the display of the instrument cluster. We recommend having the AdBlue tank refilled at your Audi partner.

ISOFIX child seat mounting and top tether for the outer rear seats

Standard mounting for practical attachment of ISOFIX child seat mounting, including additional fastening point (top tether).

You can obtain the recommended child seats from your Audi partner.

ISOFIX child seat mounting for the front-passenger seat

with passenger airbag deactivation switch, includes separate electric child-proof lock for the rear doors

| Audi Extended Warranty

Audi Extended Warranty

The Audi Extended Warranty offers longer-term protection against risk and allows you to control servicing costs even after the first 2 years of the manufacturer's guarantee. It can only be ordered directly and on purchase of a new car. Choice of 9 service life/total mileage combinations. Ask your Audi partner for more detailed information.

Audi Genuine Accessories. As individual as the life you lead.

The Audi A7 Sportback: dynamic forms combined with sporty elegance. This is how you get from A to B in an expressive way every time. And then, inspired, just keep driving. Not least because your Audi A7 Sportback is prepared for a multitude of individual requirements from A to Z. Thanks to Audi Genuine Accessories: products that will inspire you to new destinations again and again. And keep all our quality promises day in, day out. Benefit from customised solutions with convincing design and functionality. Because creativity in development and high production standards alongside numerous testing procedures are just as decisive for Audi Genuine Accessories as for the Audi vehicles themselves. Discover which tailor-made ideas Audi Genuine Accessories have ready for your lifestyle. A few highlights are illustrated here – please contact your Audi partner for more information on the complete range.



Further information can be obtained from the Audi A7 accessories catalogue, at www.audi.com and from your Audi partner.

Ski and luggage box (405 l)

New Audi design with improved aerodynamics thanks to a flat, sporty look. Platinum grey roof box with brilliant black side blade and chrome-plated Audi rings; high-quality look with no visible rivets. Lockable and can be opened from both sides for easy loading and unloading. With interior handle for closing the box. Simple quick-release fastening system including torque limiting. Suitable for transporting skis up to a length of 1.90 m. Advanced position allows better access to the luggage compartment. Maximum permissible load 75 kg.





Cast aluminium wheels in 5-arm parabola design, gloss turned finish¹, anthracite

Exceptional design, perfectly matched to your Audi A7. With arms in a gloss turned finish, size 9 J x 20. For tyre size 265/30 R 20².

Navigation update (not shown)

Map data containing upgraded contents, e.g. new roads, points of interest and restaurants. For added convenience and a more relaxed driving experience. Our tip: combine the update with your vehicle's next service interval. For more detailed information, please contact your Audi partner.

Audi tracking system plus (not shown)

Enables a stolen vehicle to be located and tracked via GPS/GSM technology in 27 European countries. With automatic driver recognition and intelligent restart inhibitor. For more detailed information, please contact your Audi partner.

Footrest and pedal caps in stainless steel (not shown)

Dazzling and practical at the same time: the footrest and pedal covers are made of brushed stainless steel. The rubber coating on the surface ensures a better grip. Available for automatic and manual transmissions.

¹ Please note the special information relating to wheels on page 100.

² You will find specifications on the technical characteristics of tyres on page 101.



Cycle rack for trailer towing hitch

Cycle rack (also suitable for e-bikes) for up to 2 bicycles with a maximum load of 60 kg.³ Bicycles can be locked to the rack and the cycle rack to the vehicle using the same key. Movable wheel supports offer a secure hold. Free access to the luggage compartment thanks to practical folding mechanism. The cycle rack can be folded away and stored in the bag provided, taking up little space. An expansion kit for a third bicycle is available as an option.

Audi Entertainment mobile

The second generation Rear Seat Entertainment comprises a 9-inch screen with integrated DVD player for installation on the front-seat backrests. Excellent image quality thanks to digital high resolution screen, high functionality and numerous connection options, e.g. the separately available Bluetooth headset. With the new holder for mobile devices, it is easy to attach and can also be used outside the vehicle.



³ Please note the information in the Owner's Manual on the maximum nose weight and gross weight of your vehicle. The fuel consumption and CO₂ emission figures as well as the efficiency classes can be found from page 98 onwards.

Model	A7 Sportback 2.8 FSI quattro (162 kW)	A7 Sportback 3.0 TFSI quattro (245 kW)
Engine type	V6 cylinder petrol engine with direct fuel injection and Audi valvelift system	V6 petrol engine with direct fuel injection and mechanical supercharger
Displacement in cc (valves per cylinder)	2,773 (4)	2,995 (4)
Max. output ¹ in kW at rpm	162/5,750–6,500	245/5,300–6,500
Max. torque in Nm at rpm	280/3,000–5,000	440/2,900–5,300
Power transmission/wheels		
Drive type	quattro® permanent all-wheel drive	quattro® permanent all-wheel drive
Transmission type	7-speed S tronic	7-speed S tronic
Wheels	Forged aluminium wheels, 8 J x 17	Forged aluminium wheels, 8 J x 17
Tyres	235/55 R 17 ²	235/55 R 17 ²
Weights/capacities		
Unladen weight ³ in kg	1,830	1,885
Gross vehicle weight in kg	2,365	2,420
Permissible roof load limit/ nose weight in kg	100/85	100/85
Trailer load limit ⁴ in kg unbraked	750	750
12 % gradient	2,000	2,100
8 % gradient	2,100	2,100
Fuel tank capacity, approx. in l	65	65
Performance/consumption⁵		
Top speed in km/h	235	250 ⁶
Acceleration 0–100 km/h in s	8.3	5.3
Fuel grade	Sulphur-free super RON 95 ⁷	Sulphur-free super RON 95 ⁷
Fuel consumption ⁸ in l/100 km		
urban	10.7	10.0
extra-urban	6.5	6.2
combined	8.0	7.6
CO ₂ emissions ⁸ in g/km		
urban	249	230
extra-urban	151	144
combined	187	176
Efficiency class/emission standard	D/EU5	C/EU6

Explanation of ¹ to ¹⁰ on page 100.

Model	A7 Sportback 3.0 TDI ultra (160 kW) ⁹	A7 Sportback 3.0 TDI clean diesel quattro (160 kW) ⁹	A7 Sportback 3.0 TDI clean diesel quattro (200 kW) ⁹	A7 Sportback 3.0 TDI clean diesel quattro (235 kW) ⁹
Engine type	V6 diesel engine with common rail injection system and turbocharging	V6 diesel engine with common rail injection system and turbocharging	V6 diesel engine with common rail injection system and turbocharging	V6 diesel engine with common rail injection system and turbocharging
Displacement in cc (valves per cylinder)	2,967 (4)	2,967 (4)	2,967 (4)	2,967 (4)
Max. output ¹ in kW at rpm	160/4,000–4,750	160/3,250–4,500	200/3,500–4,250	235/3,900–4,600
Max. torque in Nm at rpm	400/1,250–3,750	500/1,250–3,000	580/1,500–3,250	650/1,400–2,800
Power transmission/wheels				
Drive type	Front-wheel drive	quattro [®] permanent all-wheel drive	quattro [®] permanent all-wheel drive	quattro [®] permanent all-wheel drive
Transmission type	7-speed S tronic	7-speed S tronic	7-speed S tronic	8-speed tiptronic
Wheels	Forged aluminium wheels, 8 J x 17	Forged aluminium wheels, 8 J x 17	Forged aluminium wheels, 8 J x 17	Forged aluminium wheels, 8 J x 17
Tyres	235/55 R 17 ²	235/55 R 17 ²	235/55 R 17 ²	235/55 R 17 ²
Weights/capacities				
Unladen weight ³ in kg	1,830	1,900	1,905	1,970
Gross vehicle weight in kg	2,365	2,435	2,440	2,505
Permissible roof load limit/ nose weight in kg	100/85	100/85	100/85	100/85
Trailer load limit ⁴ in kg unbraked	750	750	750	750
12 % gradient	2,000	2,000	2,000	2,100
8 % gradient	2,100	2,100	2,100	2,100
Fuel tank capacity, approx. in l	73	73	73	73
Performance/consumption⁵				
Top speed in km/h	239	239	250 ⁶	250 ⁶
Acceleration 0–100 km/h in s	7.3	6.8	5.7	5.2
Fuel grade	Sulphur-free diesel ¹⁰	Sulphur-free diesel ¹⁰	Sulphur-free diesel ¹⁰	Sulphur-free diesel ¹⁰
Fuel consumption ⁸ in l/100 km				
urban	5.5	6.0	6.0	7.4
extra-urban	4.3	4.7	4.7	5.4
combined	4.7	5.2	5.2	6.1
CO ₂ emissions ⁸ in g/km				
urban	142	156	156	195
extra-urban	111	124	124	142
combined	122	136	136	162
Efficiency class/emission standard	A+/EU6	A/EU6	A/EU6	B/EU6

Model	S7 Sportback 4.0 TFSI quattro (331 kW)
Engine type	V8 cylinder petrol engine with direct fuel injection, Audi valvelift system and Audi cylinder on demand
Displacement in cc (valves per cylinder)	3,993 (4)
Max. output ¹ in kW at rpm	331/5,800-6,400
Max. torque in Nm at rpm	550/1,400-5,700
Power transmission/wheels	
Drive type	quattro® permanent all-wheel drive
Transmission type	7-speed S tronic
Wheels	Cast aluminium wheels, 8.5 J x 19
Tyres	255/40 R 19 ²
Weights/capacities	
Unladen weight ³ in kg	2,030
Gross vehicle weight in kg	2,565
Permissible roof load limit/ nose weight in kg	100/85
Trailer load limit ⁴ in kg unbraked 12 % gradient	750 2,100
8 % gradient	2,100
Fuel tank capacity, approx. in l	75
Performance/consumption⁵	
Top speed in km/h	250 ⁶
Acceleration 0-100 km/h in s	4.6
Fuel grade	Sulphur-free super RON 95 ⁷
Fuel consumption ⁸ in l/100 km urban	13.2
extra-urban	7.0
combined	9.3
CO ₂ emissions ⁸ in g/km urban	306
extra-urban	163
combined	215
Efficiency class/emission standard	E/EU6

Explanatory notes

¹ The figure given was calculated using the specified measuring procedure (current version of Directive 80/1269/EEC).

² You will find specifications on the technical characteristics of tyres in the adjacent table.

³ Unladen vehicle weight includes driver (68 kg), luggage (7 kg) and fuel tank 90 % full, calculated in accordance with the current version of EC Directive 92/21/EEC. Optional equipment may increase the car's unladen weight and drag coefficient, whereupon the possible payload limit and the top speed will be reduced accordingly.

⁴ The engine's power output always decreases with increasing altitude. At 1,000 m above sea level, and for every additional 1,000 m, deduct 10 % from the weight of the outfit (trailer load limit + gross weight of the towing vehicle). Figure for trailer load limit applies to factory-fitted trailer towing hitch. If using the vehicle with a trailer towing hitch for commercial purposes, a digital tachograph may be required under certain conditions.

⁵ A vehicle's fuel consumption and CO₂ emissions do not just depend on how efficiently the vehicle uses the fuel, but are also influenced by driving behaviour and other non-technical factors. CO₂ is the greenhouse gas primarily responsible for global warming.

⁶ Regulated.

⁷ We recommend using sulphur-free super unleaded RON 95 fuel complying with DIN EN 228. If this is not available, use sulphur-free regular unleaded RON 91 fuel complying with DIN EN 228; power output will be slightly reduced. Unleaded RON 95 fuel with a maximum ethanol content of 10 % (E10) can generally be used. Fuel consumption details refer to operation with RON 95 fuel complying with 692/2008/EC.

⁸ The figures stated were calculated using the specified measuring procedures. The figures do not refer to one individual vehicle and do not form part of any offer, but rather should be used purely for purposes of comparison between the different vehicle models.

⁹ Refill the separate AdBlue® tank as indicated by the information in the display of the instrument cluster. We recommend having the AdBlue tank refilled by your Audi partner.















¹⁰ We recommend using sulphur-free diesel in accordance with DIN EN 590. If this is not available, use diesel complying with DIN EN 590.

Important note:

Special information about the wheels: wheels with gloss turned finish as well as polished or partly polished aluminium wheels should not be used in wintry road conditions. For manufacturing reasons, these wheel surfaces do not have sufficient corrosion protection for such use and they can be permanently damaged by road salt or similar.

Classifications of tyre parameters

The table shows the range of fuel efficiency, wet grip and exterior noise emission classes for the different tyre sizes of the Audi A7 Sportback and Audi S7 Sportback.

	Tyre size	Fuel efficiency class	Wet grip class	Exterior noise emission class
Summer tyres	235/55 R 17	E-C	C-A	71-67  - 
	255/45 R 18	E-C	C-A	72-69  - 
	255/40 R 19	E-C	C-A	73-69  - 
	265/35 R 20	E	C-A	73-69  - 
	275/30 R 21	E	B	73-70  - 
Winter tyres	235/55 R 17	E	E-C	72-70 
	235/45 R 19	E	E-C	72-70  - 
	265/35 R 20	E	C	70 

It is not possible to order a specific tyre.

Ask your Audi partner about the range of tyres available in your country.

Audi A7 Sportback

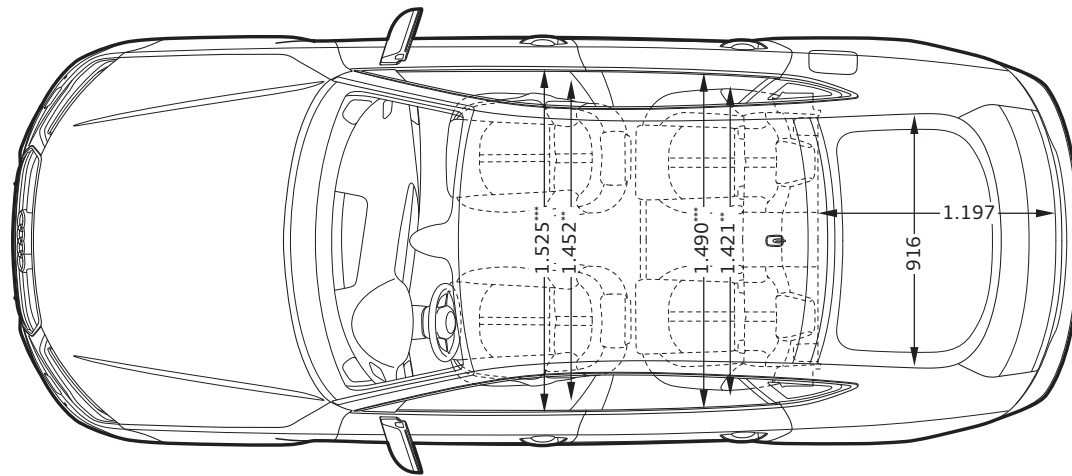
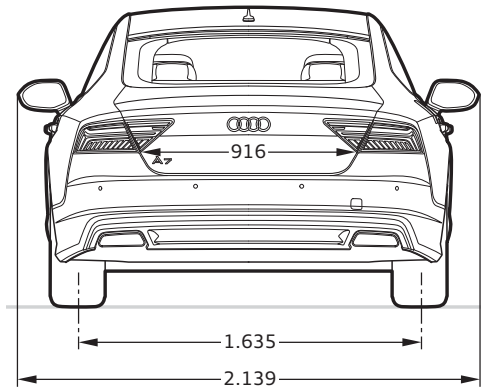
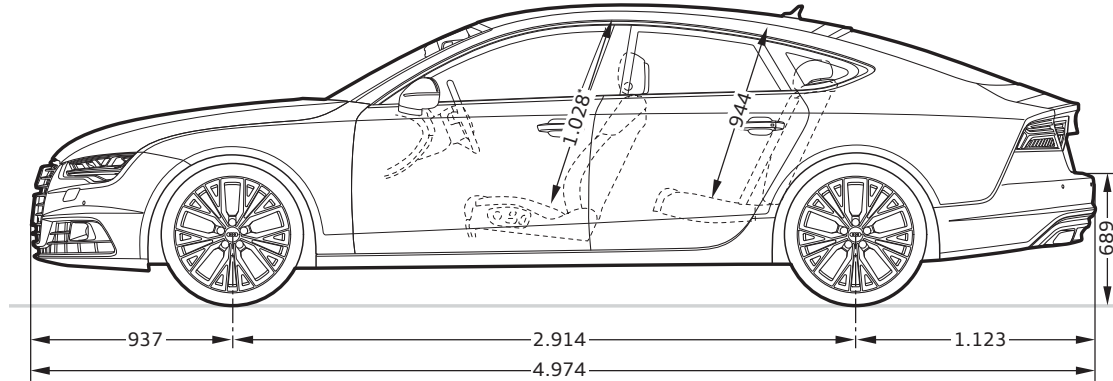
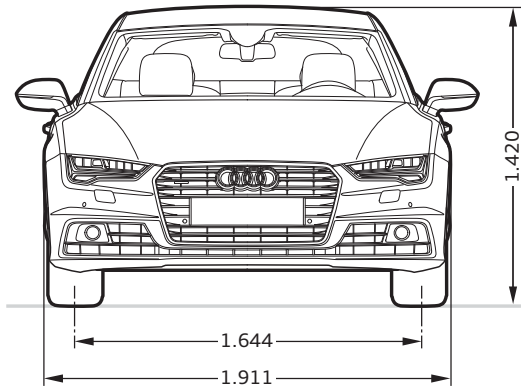
**Dimensions in millimetres.**

Dimensions are for vehicle at unladen weight.

Luggage capacity 535/1,390 l (measured by the VDA method using 200 x 100 x 50 mm blocks; 2nd value is with the rear seat backrest folded down and the vehicle loaded up to roof height).

Turning circle approx. 11.9 m.

*Maximum headroom. **Elbow room width. ***Shoulder room width.

Audi S7 Sportback

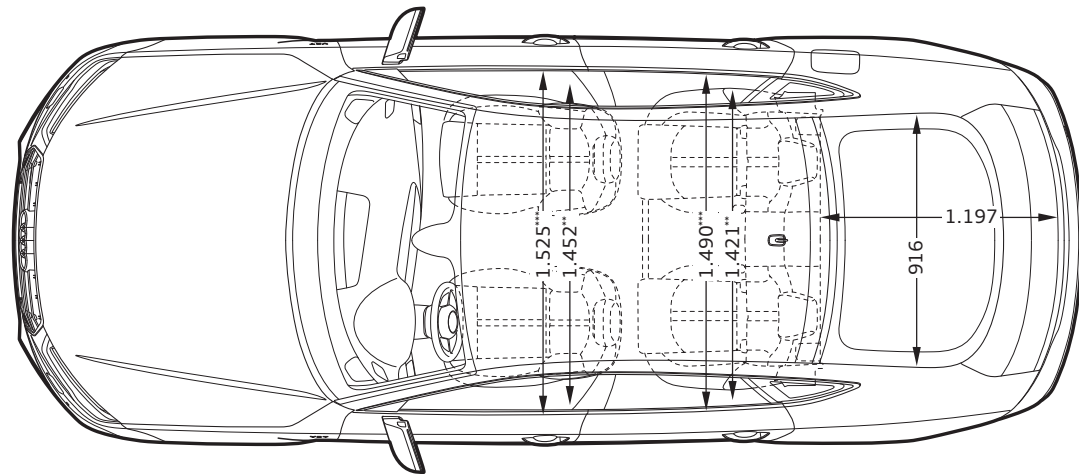
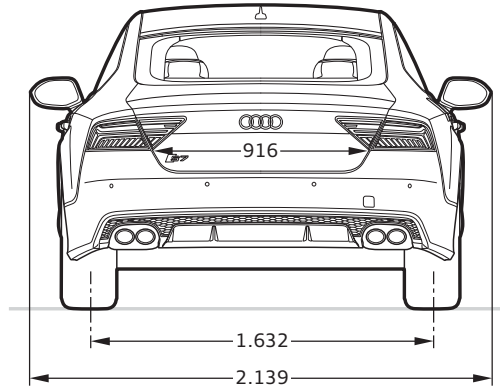
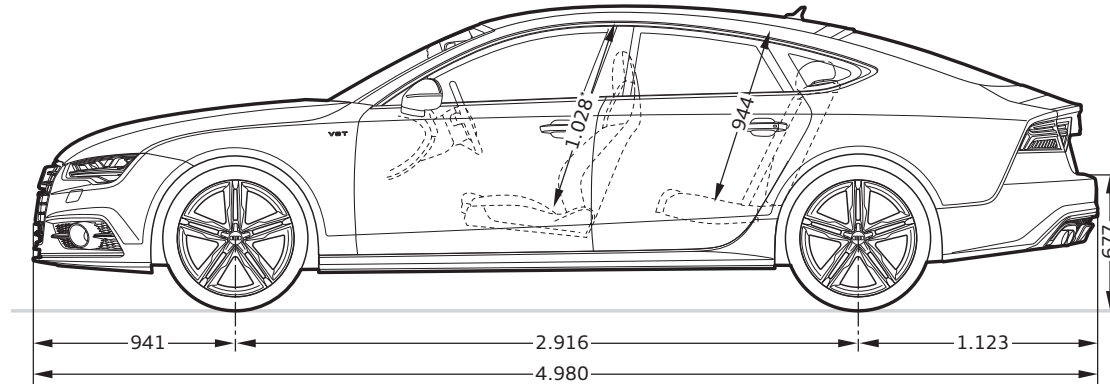
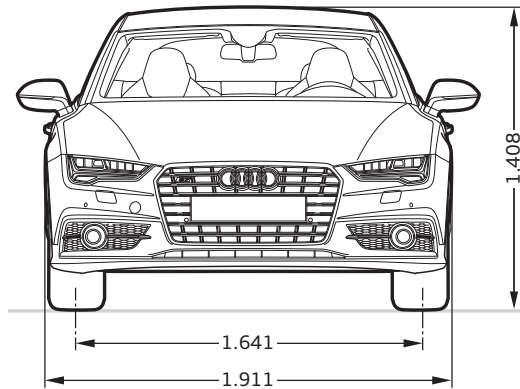















**Dimensions in millimetres.**

Dimensions are for vehicle at unladen weight.

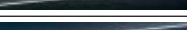
Luggage compartment volume 535/1,390 l (measured by the VDA method using 200 x 100 x 50 mm blocks; second value is with the rear seat backrest folded down and the vehicle loaded up to roof height).

Turning circle approx. 11.9 m.









*Maximum headroom. **Elbow room width. ***Shoulder room width.









	Page	A7 Sportback	S7 Sportback
Lines and packages	62		
S line exterior package		■	—
S line sport package		■	—
Audi design selection Arras red		—	■
Audi exclusive	66		
Audi exclusive line		■	—
Solid paint finishes	70		
 Ibis white		□	□
 Brilliant black		□	□
Metallic paint finishes	70		
 Glacier white, metallic		■	■
 Floret silver, metallic		■	■
 Cuvée silver, metallic		■	—
 Tornado grey, metallic		■	■
 Oolong grey, metallic		■	■
 Dakota grey, metallic		■	—
 Havana black, metallic		■	■
 Mythos black, metallic		■	■
 Moonlight blue, metallic		■	■
 Carat beige, metallic		■	■
Pearl effect paint finishes	71		
 Misano red, pearl effect		■ ¹	■
 Garnet red, pearl effect		■	—
 Sepang blue, pearl effect		—	■
 Daytona grey, pearl effect		■ ²	■





□ Standard equipment ■ Optional equipment — Not available

Country-specific variations possible. Please find out from your local Audi partner which equipment is standard and what optional equipment is available in your country.













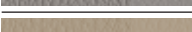

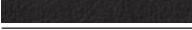
More detailed descriptions of a selection of items from the equipment range can be found from page 52 onwards.

	Page	A7 Sportback	S7 Sportback
Customised paint finishes	71		
 Audi exclusive customised paint finishes		■	■
Wheels/tyres	72		
 17" forged aluminium wheels in 6-arm design		□	—
 18" cast aluminium wheels in 7-arm dynamic design		■	—
 19" cast aluminium wheels in 5-parallel-spoke design (S design)		—	□
 19" cast aluminium wheels in 5-arm Y design		■	—
 19" cast aluminium wheels in 5-V-spoke design		■	■
 19" Audi Sport cast aluminium wheels in 5-V-spoke design, matt titanium look, gloss turned finish ³		■	—
 19" Audi Sport cast aluminium wheels in 7-twin-spoke design		■	—
 19" cast aluminium wheels in 10-spoke design		■	—

	Page	A7 Sportback	S7 Sportback
	20" cast aluminium wheels in 5-parallel-spoke star design (S design)	—	■
	20" forged aluminium wheels in 5-spoke W design	■	—
	20" forged aluminium wheels in 5-spoke W design, contrasting grey, partly polished³	■	—
	20" Audi Sport cast aluminium wheels in 5-twin-spoke design	■	■
	20" Audi Sport cast aluminium wheels in 5-twin-spoke design in matt titanium look, gloss turned finish³	■	■
	20" Audi Sport cast aluminium wheels in 5-spoke blade design	■	■
	20" Audi Sport cast aluminium wheels in 5-spoke blade design, matt titanium look, gloss turned finish³	■	■
	20" Audi Sport cast aluminium wheels in 10-Y-spoke design	■	■

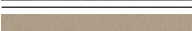
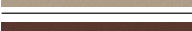
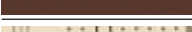
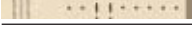
	Page	A7 Sportback	S7 Sportback
	21" Audi Sport cast aluminium wheels in 5-arm rotor design	■	■
	21" Audi Sport cast aluminium wheels in 5-arm rotor design, matt titanium look, gloss turned finish³	■	■
	17" forged aluminium winter wheels in 6-arm design	■	—
	19" cast aluminium winter wheels in 10-spoke design	■	■
	20" cast aluminium winter wheels in 5-parallel-spoke star design (S design)	—	■
	Tyre repair kit	<input type="checkbox"/>	<input type="checkbox"/>
	Spare wheel, space-saving	■	■
	Tyre pressure loss indicator	<input type="checkbox"/>	<input type="checkbox"/>
	Anti-theft wheel bolts	■	■
	Vehicle tool kit	<input type="checkbox"/>	<input type="checkbox"/>
	Vehicle jack	■	■
	Seats	74	
	Standard seats, front	<input type="checkbox"/>	—
	Customised contour seats, front	■	■
	Sport seats, front	■	—
	S sport seats, front	■ ¹	<input type="checkbox"/>

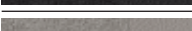
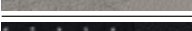
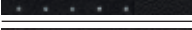

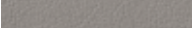



¹ Only available in conjunction with S line sport package. ² Only available in conjunction with S line sport package or S line exterior package. ³ Please note the special information relating to wheels on page 100.



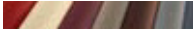

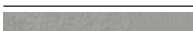
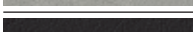
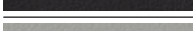
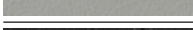

	Page	A7 Sportback	S7 Sportback
Seat upholstery for standard seats, front	76		
 Horizon cloth, black		<input type="checkbox"/>	—
 Part-leather, black ¹		<input checked="" type="checkbox"/>	—
 Part-leather, flint grey ¹		<input checked="" type="checkbox"/>	—
 Part-leather, Atlas beige ¹		<input checked="" type="checkbox"/>	—
 Part-leather, nougat brown ¹		<input checked="" type="checkbox"/>	—
 Milano leather, black ¹		<input checked="" type="checkbox"/>	—
 Milano leather, flint grey ¹		<input checked="" type="checkbox"/>	—
 Milano leather, Atlas beige ¹		<input checked="" type="checkbox"/>	—
 Milano leather, nougat brown ¹		<input checked="" type="checkbox"/>	—
 Audi exclusive leather upholstery and trim ¹		<input checked="" type="checkbox"/>	—
Seat upholstery for customised contour seats, front	76		
 Valcona leather, black ¹		<input checked="" type="checkbox"/>	<input checked="" type="checkbox"/>
 Valcona leather, flint grey ¹		<input checked="" type="checkbox"/>	<input checked="" type="checkbox"/>
 Valcona leather, Atlas beige ¹		<input checked="" type="checkbox"/>	—
 Valcona leather, nougat brown ¹		<input checked="" type="checkbox"/>	—
 Valcona leather, alabaster white		<input checked="" type="checkbox"/> ²	—
 Audi exclusive leather upholstery and trim ¹		<input checked="" type="checkbox"/>	<input checked="" type="checkbox"/>
Seat upholstery for sport seats, front	76		
 Milano leather, black		<input checked="" type="checkbox"/>	—
 Alcantara/leather, black		<input checked="" type="checkbox"/>	—
 Alcantara/leather, flint grey		<input checked="" type="checkbox"/>	—
 Perforated Alcantara/leather, black		<input checked="" type="checkbox"/> ³	—
 Valcona leather, black		<input checked="" type="checkbox"/>	—
 Valcona leather, flint grey		<input checked="" type="checkbox"/>	—
 Valcona leather, nougat brown		<input checked="" type="checkbox"/>	—







Standard equipment Optional equipment Standard/optional equipment varies by model — Not available

Country-specific variations possible. Please find out from your local Audi partner which equipment is standard and what optional equipment is available in your country.

More detailed descriptions of a selection of items from the equipment range can be found from page 52 onwards.

	Page	A7 Sportback	S7 Sportback
 Audi exclusive leather upholstery and trim		<input checked="" type="checkbox"/>	—
Seat upholstery for S sport seats, front	76		
 Alcantara/leather, black		—	<input type="checkbox"/>
 Alcantara/leather, lunar silver		—	<input type="checkbox"/>
 Valcona leather, black		<input checked="" type="checkbox"/> ³	—
 Valcona leather, lunar silver		<input checked="" type="checkbox"/> ³	—
 Valcona leather, black with contrasting stitching		—	<input checked="" type="checkbox"/>
 Valcona leather, lunar silver with contrasting stitching		—	<input checked="" type="checkbox"/>
 Valcona leather, Arras red with contrasting stitching		—	<input checked="" type="checkbox"/> ⁴
 Audi exclusive leather upholstery and trim		—	<input checked="" type="checkbox"/>
Cloth and leather upholstery and trim	76		
Horizon upholstery and trim		<input type="checkbox"/>	—
Part-leather upholstery and trim		<input checked="" type="checkbox"/>	—
Alcantara/leather combination		<input checked="" type="checkbox"/>	<input type="checkbox"/>
Milano leather upholstery and trim		<input checked="" type="checkbox"/>	—
Valcona leather upholstery and trim		<input checked="" type="checkbox"/>	<input checked="" type="checkbox"/>
Audi exclusive leather upholstery and trim (package 1) in Valcona leather		<input checked="" type="checkbox"/>	<input checked="" type="checkbox"/>
Audi exclusive leather upholstery and trim (package 2) in Valcona leather		<input checked="" type="checkbox"/>	<input checked="" type="checkbox"/>
Audi exclusive leather upholstery and trim (package 1) in Alcantara/Valcona leather		<input checked="" type="checkbox"/>	<input checked="" type="checkbox"/>
Leather packages	78		
Leather-covered armrests in the door trims		<input checked="" type="checkbox"/>	<input checked="" type="checkbox"/>
Leather package		<input checked="" type="checkbox"/>	—
Leather package including airbag cover		<input checked="" type="checkbox"/>	<input checked="" type="checkbox"/>
Audi exclusive leather package including airbag cover		<input checked="" type="checkbox"/>	<input checked="" type="checkbox"/>
Extended Audi exclusive leather package		<input checked="" type="checkbox"/>	<input checked="" type="checkbox"/>

	Page	A7 Sportback	S7 Sportback
Audi exclusive piping for customised contour seats		■	■
Audi exclusive leather seat trims		■	■
Seating comfort	78		
Front seats, electrically adjustable, including memory function for the driver seat		■	□
4-way lumbar support for the front seats		■	□
Seat heating, front		■	■
Seat heating, front and rear		■	■
Seat ventilation, front		■	■
Massage function, front		■	■
Centre armrest, front		□	□
Rear seats	79		
Rear seat system		□	■
Rear seat system 2+1		■	–
S sport seats in the rear		■ ³	□
Headlining	79		
Headlining in cloth		□	□
Headlining in cloth, black		□ ⁵	■
Headlining in Alcantara black		■	■
Headlining in Alcantara black with coloured Audi exclusive decorative stitching		■	■
Inlays	80		
 Satin finish, silver-grey		□	–
 Satin finish, silver-beige		□	–
 Aluminium delta, silver		■	–
 Matt brushed aluminium		■ ³	□
 Carbon Atlas		–	■
 Carbon twill, red		–	■ ⁴

	Page	A7 Sportback	S7 Sportback
 Piano finish, black		■	■
 Fine grain ash, natural brown		■	■
 Walnut, dark brown		■	–
 Eucalyptus, natural		■ ²	–
 Beaufort walnut		■	■
 Aluminium/Beaufort, black		■	■
 Inlays in Audi exclusive wood		■	■
Headlights	82		
LED headlights		□	□
Audi Matrix LED headlights		■	■
Light/rain sensor		□	□
LED rear lights with dynamic indicators		□	□
High-beam assist		■	■
Adaptive brake light		□	□
Interior lighting	82		
Interior lighting		□	□
Interior and exterior lighting package		■	■
Ambient lighting		■	■
Exterior design	83		
Model name/logo		□	□
Rear spoiler		□	□
Exhaust tailpipes		□	□
Sport exhaust system		–	■
Gloss package		□	□
Audi exclusive black gloss package		■	■

¹In conjunction with seat ventilation, front, the leather on the front and outer rear seats is perforated. ²Only available in conjunction with Audi exclusive line. ³Only available in conjunction with S line sport package.

⁴Only available in conjunction with Audi design selection. ⁵Standard in conjunction with S line sport package.

	Page	A7 Sportback	S7 Sportback
Interior design	83		
Aluminium-look interior		<input type="checkbox"/>	<input type="checkbox"/>
Floor mats, front		<input type="checkbox"/>	–
Floor mats, front and rear		<input checked="" type="checkbox"/>	<input type="checkbox"/>
Audi exclusive floor mats		<input checked="" type="checkbox"/>	<input checked="" type="checkbox"/>
Audi exclusive carpet and floor mats		<input checked="" type="checkbox"/>	<input checked="" type="checkbox"/>
Pedals and footrest in stainless steel		–	<input type="checkbox"/>
Door sill trims with aluminium inlays		<input type="checkbox"/>	<input type="checkbox"/>
Steering wheels/controls	83		
Multifunction leather steering wheel in 4-spoke design		<input type="checkbox"/>	–
Multifunction leather steering wheel in 4-spoke design with shift paddles		<input type="checkbox"/> *	–
Multifunction leather steering wheel in 4-spoke design, heated		<input checked="" type="checkbox"/>	–
Multifunction sport leather steering wheel in 3-spoke design		<input checked="" type="checkbox"/>	–
Multifunction sport leather steering wheel in 3-spoke design with shift paddles		<input checked="" type="checkbox"/>	<input type="checkbox"/>
Multifunction sport leather steering wheel in 3-spoke design with shift paddles, heated		<input checked="" type="checkbox"/>	<input checked="" type="checkbox"/>
Electric steering wheel adjustment		<input checked="" type="checkbox"/>	<input checked="" type="checkbox"/>
Steering wheel rim with wooden segments		<input checked="" type="checkbox"/>	–
Audi exclusive steering wheel rim with wooden segments		<input checked="" type="checkbox"/>	–
Audi exclusive steering wheel rim in leather		<input checked="" type="checkbox"/>	<input checked="" type="checkbox"/>
Audi exclusive leather controls		<input checked="" type="checkbox"/>	<input checked="" type="checkbox"/>
Selector lever knob in leather		<input type="checkbox"/>	–
Selector lever knob in aluminium look		–	<input type="checkbox"/>
Mirrors	84		
Exterior mirrors, electrically adjustable and heated, with integrated LED indicator		<input type="checkbox"/>	<input type="checkbox"/>
Exterior mirrors, additionally electrically folding		<input checked="" type="checkbox"/>	<input checked="" type="checkbox"/>
Exterior mirrors additionally automatically dimming on both sides		<input checked="" type="checkbox"/>	<input checked="" type="checkbox"/>

Standard equipment Optional equipment Standard/optional equipment varies by model – Not available

Country-specific variations possible. Please find out from your local Audi partner which equipment is standard and what optional equipment is available in your country.

More detailed descriptions of a selection of items from the equipment range can be found from page 52 onwards.

	Page	A7 Sportback	S7 Sportback
Exterior mirrors additionally electrically folding and automatically dimming on both sides		<input checked="" type="checkbox"/>	<input checked="" type="checkbox"/>
Exterior mirror housings in aluminium look		–	<input type="checkbox"/>
Interior mirror, manual dimming		<input type="checkbox"/>	<input type="checkbox"/>
Interior mirror, automatically dimming		<input checked="" type="checkbox"/>	<input checked="" type="checkbox"/>
Roof system	84		
Slide-and-tilt glass sunroof		<input checked="" type="checkbox"/>	<input checked="" type="checkbox"/>
Glazing	85		
Heat-insulating glass		<input type="checkbox"/>	<input type="checkbox"/>
Dark-tinted windows (privacy glazing)		<input checked="" type="checkbox"/>	<input checked="" type="checkbox"/>
Insulating/acoustic glass		<input checked="" type="checkbox"/>	<input checked="" type="checkbox"/>
Insulating/acoustic glass and dark-tinted windows (privacy glazing)		<input checked="" type="checkbox"/>	<input checked="" type="checkbox"/>
Sun visors, folding and swivelling		<input type="checkbox"/>	<input type="checkbox"/>
Sun screen		<input checked="" type="checkbox"/>	<input checked="" type="checkbox"/>
Climate control	85		
Deluxe automatic air conditioning		<input type="checkbox"/>	–
4-zone deluxe automatic air conditioning		<input checked="" type="checkbox"/>	<input type="checkbox"/>
Auxiliary heating/ventilation		<input checked="" type="checkbox"/>	<input checked="" type="checkbox"/>
Closing systems	86		
Remote control key		<input type="checkbox"/>	<input type="checkbox"/>
Engine start-stop button		<input type="checkbox"/>	<input type="checkbox"/>
Luggage compartment lid, electrically opening and closing		<input type="checkbox"/>	<input type="checkbox"/>
Convenience key including sensor-controlled release of the luggage compartment lid		<input checked="" type="checkbox"/>	<input checked="" type="checkbox"/>
Power-assisted closing for the doors		<input checked="" type="checkbox"/>	<input checked="" type="checkbox"/>
Garage door opener (HomeLink)		<input checked="" type="checkbox"/>	<input checked="" type="checkbox"/>
Anti-theft alarm		<input checked="" type="checkbox"/>	<input checked="" type="checkbox"/>
Preparation for tracking system		<input checked="" type="checkbox"/>	<input checked="" type="checkbox"/>

	Page	A7 Sportback	S7 Sportback
Storage/transport	86		
Storage compartments		<input type="checkbox"/>	<input type="checkbox"/>
Storage package		<input checked="" type="checkbox"/>	<input type="checkbox"/>
Luggage compartment		<input type="checkbox"/>	<input type="checkbox"/>
Through-loading facility		–	<input type="checkbox"/>
Through-loading facility with removable ski and snowboard bag		<input checked="" type="checkbox"/>	<input checked="" type="checkbox"/>
Reversible mat		<input checked="" type="checkbox"/>	<input checked="" type="checkbox"/>
Non-smoker version		<input type="checkbox"/>	<input type="checkbox"/>
Cigarette lighter and ashtray		<input checked="" type="checkbox"/>	<input checked="" type="checkbox"/>
Provision for trailer towing hitch		<input checked="" type="checkbox"/>	<input checked="" type="checkbox"/>
Trailer towing hitch		<input checked="" type="checkbox"/>	<input checked="" type="checkbox"/>
MMI®/navigation	87		
Instrument cluster		<input type="checkbox"/>	<input type="checkbox"/>
Driver information system		<input type="checkbox"/>	–
Driver information system with colour display		<input checked="" type="checkbox"/>	<input type="checkbox"/>
Attention assist		<input type="checkbox"/>	<input type="checkbox"/>
MMI® navigation		<input checked="" type="checkbox"/>	<input checked="" type="checkbox"/>
MMI® navigation plus with MMI touch		<input checked="" type="checkbox"/>	<input checked="" type="checkbox"/>
Entertainment	88		
MMI® radio		<input type="checkbox"/>	–
MMI® radio plus		<input checked="" type="checkbox"/>	<input type="checkbox"/>
Digital Audio Broadcasting		<input checked="" type="checkbox"/>	<input checked="" type="checkbox"/>
Digital TV reception		<input checked="" type="checkbox"/>	<input checked="" type="checkbox"/>
Adapter cable set for Audi music interface		<input checked="" type="checkbox"/>	<input checked="" type="checkbox"/>
Adapter cable set plus for Audi music interface		<input checked="" type="checkbox"/>	<input checked="" type="checkbox"/>

	Page	A7 Sportback	S7 Sportback
CD changer		<input checked="" type="checkbox"/>	<input checked="" type="checkbox"/>
DVD/CD changer		<input checked="" type="checkbox"/>	<input checked="" type="checkbox"/>
Audi sound system		<input checked="" type="checkbox"/>	<input type="checkbox"/>
Bose Surround Sound		<input checked="" type="checkbox"/>	<input checked="" type="checkbox"/>
Bang & Olufsen Advanced Sound System		<input checked="" type="checkbox"/>	<input checked="" type="checkbox"/>
Preparation for Rear Seat Entertainment		<input checked="" type="checkbox"/>	<input checked="" type="checkbox"/>
Communications	90		
Audi connect		<input checked="" type="checkbox"/>	<input checked="" type="checkbox"/>
Bluetooth interface		<input checked="" type="checkbox"/>	<input type="checkbox"/>
Audi phone box		<input checked="" type="checkbox"/>	<input checked="" type="checkbox"/>
Assistance systems	90		
Hold assist		<input type="checkbox"/>	<input type="checkbox"/>
Parking system plus		<input checked="" type="checkbox"/>	<input checked="" type="checkbox"/>
Park assist with display of surroundings		<input checked="" type="checkbox"/>	<input checked="" type="checkbox"/>
Reversing camera		<input checked="" type="checkbox"/>	<input checked="" type="checkbox"/>
Front and reversing cameras		<input checked="" type="checkbox"/>	<input checked="" type="checkbox"/>
Cruise control		<input checked="" type="checkbox"/>	<input checked="" type="checkbox"/>
Audi pre sense basic		<input checked="" type="checkbox"/>	<input checked="" type="checkbox"/>
adaptive cruise control with Stop&Go function incl. Audi pre sense front		<input checked="" type="checkbox"/>	<input checked="" type="checkbox"/>
Audi side assist including Audi pre sense rear		<input checked="" type="checkbox"/>	<input checked="" type="checkbox"/>
Audi active lane assist		<input checked="" type="checkbox"/>	<input checked="" type="checkbox"/>
Assistance package including Audi pre sense plus		<input checked="" type="checkbox"/>	<input checked="" type="checkbox"/>
Head-up display		<input checked="" type="checkbox"/>	<input checked="" type="checkbox"/>
Night vision assistant		<input checked="" type="checkbox"/>	<input checked="" type="checkbox"/>
Camera-based speed limit display		<input checked="" type="checkbox"/>	<input checked="" type="checkbox"/>

	Page	A7 Sportback	S7 Sportback
Driving dynamics/brakes	93		
Audi drive select	<input type="checkbox"/>	<input type="checkbox"/>	
Sport suspension	<input checked="" type="checkbox"/>	–	
S line sport suspension	<input checked="" type="checkbox"/> ¹	–	
adaptive air suspension	<input checked="" type="checkbox"/>	–	
adaptive air suspension – sport	–	<input type="checkbox"/>	
Front-wheel drive	<input type="checkbox"/> ²	–	
quattro®	<input type="checkbox"/> ²	<input type="checkbox"/>	
quattro® with sport differential	<input checked="" type="checkbox"/> ³	<input checked="" type="checkbox"/>	
S tronic®	<input type="checkbox"/> ²	<input type="checkbox"/>	
tiptronic	<input type="checkbox"/> ²	–	
Electromechanical power steering	<input type="checkbox"/>	<input type="checkbox"/>	
Dynamic steering	<input checked="" type="checkbox"/>	<input checked="" type="checkbox"/>	
Brake system	<input type="checkbox"/>	<input type="checkbox"/>	
Brake callipers, painted black	–	<input type="checkbox"/>	
Ceramic brakes	<input checked="" type="checkbox"/> ⁴	<input checked="" type="checkbox"/>	
Electromechanical parking brake	<input type="checkbox"/>	<input type="checkbox"/>	
Technology/safety	94		
Body, galvanised	<input type="checkbox"/>	<input type="checkbox"/>	
Audi cylinder on demand	–	<input type="checkbox"/>	
Active Noise Cancellation	–	<input type="checkbox"/>	
Antilock Brake System (ABS) with Electronic Brake Force Distribution (EBD)	<input type="checkbox"/>	<input type="checkbox"/>	
Anti-Slip Regulation (ASR)	<input type="checkbox"/>	<input type="checkbox"/>	
Electronic Differential Lock (EDL)	<input type="checkbox"/>	<input type="checkbox"/>	
Electronic Stabilisation Control (ESC)	<input type="checkbox"/>	<input type="checkbox"/>	

	Page	A7 Sportback	S7 Sportback
Electronic Stabilisation Control (ESC) with electronic axle-differential lock	<input type="checkbox"/> ⁵	–	
65 l fuel tank	<input type="checkbox"/> ⁶	–	
73 l fuel tank	<input type="checkbox"/> ⁷	–	
75 l fuel tank	<input checked="" type="checkbox"/> ⁸	<input type="checkbox"/>	
Recuperation	<input type="checkbox"/>	<input type="checkbox"/>	
Start-stop system	<input type="checkbox"/>	<input type="checkbox"/>	
Audi TDI clean diesel	<input type="checkbox"/> ⁷	–	
Airbags	<input type="checkbox"/>	<input type="checkbox"/>	
Side airbags, front, and head airbag system	<input type="checkbox"/>	<input type="checkbox"/>	
Side airbags, rear	<input checked="" type="checkbox"/>	<input checked="" type="checkbox"/>	
Side impact protection in the doors	<input type="checkbox"/>	<input type="checkbox"/>	
Integrated head restraint system	<input type="checkbox"/>	<input type="checkbox"/>	
Safety steering column	<input type="checkbox"/>	<input type="checkbox"/>	
Seat belts	<input type="checkbox"/>	<input type="checkbox"/>	
Seat belts, crimson red	<input checked="" type="checkbox"/>	<input checked="" type="checkbox"/>	
Audi exclusive seat belts	<input checked="" type="checkbox"/>	<input checked="" type="checkbox"/>	
Seat belt reminder	<input type="checkbox"/>	<input type="checkbox"/>	
Child-proof lock for the rear doors	<input type="checkbox"/>	<input type="checkbox"/>	
ISOFIX child seat mounting and top tether for the outer rear seats	<input type="checkbox"/>	<input type="checkbox"/>	
ISOFIX child seat mounting for the front-passenger seat	<input checked="" type="checkbox"/>	<input checked="" type="checkbox"/>	
First-aid kit	<input checked="" type="checkbox"/>	<input checked="" type="checkbox"/>	
Warning triangle	<input checked="" type="checkbox"/>	<input checked="" type="checkbox"/>	
Audi Extended Warranty	95		
Audi Extended Warranty	<input checked="" type="checkbox"/>	<input checked="" type="checkbox"/>	

Standard equipment Optional equipment – Not available

Country-specific variations possible. Please find out from your local Audi partner which equipment is standard and what optional equipment is available in your country. More detailed descriptions of a selection of items from the equipment range can be found from page 52 onwards.

Equipment for the Audi A7 Sportback illustrated (p. 4–21):

Paint finish: cuvée silver, metallic

Wheels: forged aluminium wheels in 5-spoke W design

Seats/seat upholstery: customised contour seats, front in Valcona leather, Atlas beige with seat ventilation

Inlays: Beaufort oak

Equipment for the Audi S7 Sportback illustrated (p. 22–33):

Paint finish: Daytona grey, pearl effect

Wheels: cast aluminium wheels in 5-parallel-spoke star design

Seats/seat upholstery: S sport seats, front, in Valcona leather, Arras red with contrasting stitching

Inlays: carbon twill, red

¹ Only available in conjunction with S line sport package. ² The availability of your desired engine variant can be found in the technical data. ³ Only for A7 3.0 TDI clean diesel quattro (200 kW), A7 3.0 TDI clean diesel quattro (235 kW) and A7 3.0 TFSI quattro (245 kW). ⁴ Only for A7 3.0 TFSI quattro (235 kW) and A7 3.0 TDI clean diesel quattro (235 kW). ⁵ Only for A7 3.0 TDI ultra (160 kW). ⁶ Only for FSI and TFSI models.

⁷ Only for TDI models. ⁸ Only for TFSI models.

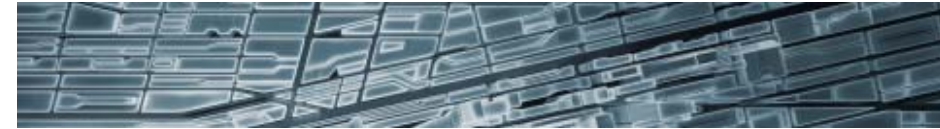

Discover



The Audi experience

The fascination of Audi can be experienced in many different ways. Audi City in London, for example, gives you digital access to all models at their actual size and in real time. And of course it is always worth visiting one of the major motor shows. This is where Audi always presents its new models and invites you to take a look at how the future is being shaped with "Vorsprung durch Technik". Anyone interested in seeing how Audi is already putting this into practice will find fascinating insight in the "Vorsprung durch Technik" online special at www.audi.com. But a look back can also be rewarding: at the Audi museum mobile in Ingolstadt, history and high-tech go hand in hand. A total of 130 historic exhibits and state-of-the-art forms of presentation make for a

thrilling symbiosis. Plus, Audi driving experience allows you to live the excitement and countless possibilities of current Audi models. Here, pure driving enjoyment is combined with valuable learning effects. This is ensured by a team of specially trained and highly qualified instructors who provide practical tips to help you optimise your driving skills. All this can now also be enjoyed at the recently opened Audi driving experience center in Neuburg, near Ingolstadt. Facilities here include a circuit, up to 3.4 kilometres that features challenging combinations of bends, a 30,000 m² dynamic driving area and an offroad section where Q models can be put through their paces.





Responsibility

Living up to our responsibilities is a principle that is firmly anchored in Audi strategy. Alongside commercial success and international competitiveness, our responsibility toward company employees and society as a whole is a key consideration, as is protecting the environment and conserving resources. And what is true in the details – our catalogues are printed on FSC-certified paper – also holds in general: Audi develops cars that are not only sporty and emotive but also ever more efficient. In the long run, Audi

wants its products to allow CO₂-neutral mobility. Seeing to it that production in Audi plants gradually becomes CO₂-neutral is another aspect of our comprehensive approach. Audi is also committed to society – particularly in the fields of education, technology and social projects. At Audi, sustainability is closely linked with how we see the future: the Audi Urban Future Initiative sees Audi working with international experts to get to the root of future urban challenges and trends in mobility.

the world of Audi.



Choosing an Audi means choosing a brand that offers more. More individuality. More exclusivity. More fascination.



Team spirit

Motorsport is a driving force behind the brand. For years Audi has been among the champions in various racing series, for instance the 24 Hours of Le Mans or the DTM German Touring Car Masters. The values that are crucial in many different areas of sport are also central ones for Audi: precision, passion and technology. No coincidence then that Audi has been sponsoring sporting

events for many years. In the world of winter sports, for example, Audi has been the main sponsor of the German Ski Association (DSV) for almost three decades and has also partnered 14 other national alpine teams. In football, we support national and international teams. And Audi is also a partner for the German Olympic Sports Confederation.

www.audi.com

Information on all the topics mentioned above can be found on our website: www.audi.com.



www.audi.com



www.audi.com/driving



configurator.audi.com



www.audi.com/cr



www.audi.com/vorsprung-durch-technik



AUDI AG
85045 Ingolstadt
www.audi.com
Valid from June 2014

Printed in Germany
433/1130.72.18

The models and equipment versions illustrated and described in this brochure and some of the services listed are not available in all countries. Some of the cars illustrated are equipped with optional features for which an extra charge is made. Details concerning the delivery specifications, appearance, performance, dimensions and weights, fuel consumption and running costs of the vehicle were correct to the best of our knowledge at the time of going to press. Deviations from the colours and shapes shown in the illustrations may occur. No liability is accepted for errors and printing errors. The right to introduce modifications is reserved. Not to be reproduced, including in part, without the written approval of AUDI AG.

This brochure is printed on paper made from pulp bleached without the use of chlorine.

