

The C-Class



Mercedes-Benz

s and upwards. Incorporating outstanding technology, design and materials. A new generation with its own rules. You can have it all. But with enjoyment.
CONTROL PACKAGE. Suspension with selective damping and the optional Dynamic Handling package. ATTENTION ASSIST. Responsible-minded on the other
onal: live for today and think of tomorrow. Advanced Parking Guidance. The beguiling form of the C-Class – with its powerful and provocative front s
calm it down again: up to ten assistance systems, latest-generation telematics. PRE-SAFE®. With style wherever you look: a new dashboard, new surfac
all the functionality you could wish for. Now there is space to match the style. A new generation: individual and spontaneous. 7G-TRONIC. Its purpos
ing pleasure. Panoramic Sun-Roof. True perfection: nothing needs to be added or taken away. With enhanced stature and a more mature appearance.
And LED tail lights which first draw you in and then cast their spell. Impressive details wherever you look. **New generation of Agility.** The C-Class: it
lead, its path onwards and upwards. Intelligent Light System. Incorporating outstanding technology, design and materials. A new generation with its

A new generation of Agility.





The new-generation C-Class goes its own way simply because it can. Confident and captivating, with a striking, masculine exterior, sophisticated new interiors and state-of-the-art innovations. Powerful yet efficient engine options and 7G-TRONIC automatic transmission redefine performance unlike any other.

The C-Class

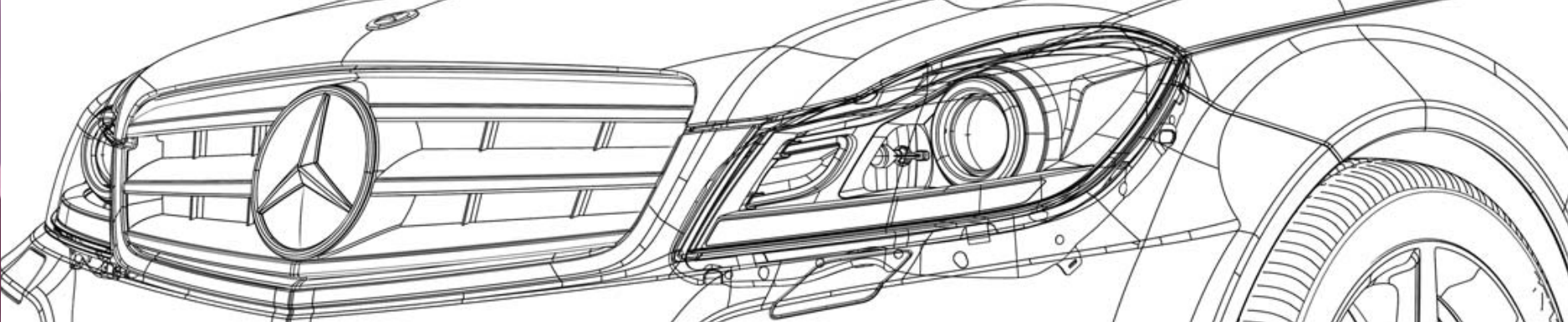

Perfection in motion: diesel and petrol engines, transmissions, chassis and suspension.

Drive system & chassis | from page 30

All-round protection: state-of-the-art technology for safe driving and the right response in the event of danger or an accident.

Safety | from page 38

High-performance sport as standard: the equipment for the C 63 AMG and the options available from the AMG Performance Studio.

AMG | from page 46

All about the driver: design and equipment lines.

Equipment & appointments | from page 54

Impressive in every detail: dimensions, paintwork and technical data.

Facts & colours | from page 84

They say nothing's perfect.
We beg to differ.



The C-Class knows exactly where it comes from and where it wants to go. Its aspiration is to lead, its path onwards and upwards. Incorporating outstanding technology, design and materials. A new generation with its own rules.



As impressive inside as it is outside.

The beguiling form of the C-Class – with its powerful and provocative front section – sets the heart racing. The comfort and convenience features then calm it down again: assistance systems, latest-generation telematics. With style wherever you look: a new dashboard, new surfaces, new trims. A revolution of inner values.

A wide-angle, high-quality photograph of a Mercedes-Benz car's interior. The view is from the driver's perspective, looking towards the front passenger seat. The interior is finished with a light tan or beige leather. The dashboard is dark, featuring a central infotainment screen displaying a navigation map. The steering wheel is leather-wrapped with the Mercedes-Benz logo in the center and silver accents. The instrument cluster behind the steering wheel shows several analog gauges. The center console has a gear shifter and handbrake. The overall atmosphere is one of luxury and precision.

What lies beneath the pristine surface?
More pristine surfaces.

Never accept less.
Except when it comes to emissions.

Save fuel, reduce emissions: the enhanced aerodynamics and BlueEFFICIENCY show the way ahead without compromising on performance, dynamism or sportiness. Now less really does mean more.





Pampers you.
Blows everything else away.

Discover what it's like to have it all. The control that comes with the AGILITY CONTROL suspension package with selective damping. And the responsibility of BlueEFFICIENCY and direct injection. Because there are some who will settle for nothing less than everything.

Open sunroof. Drop jaws.

Panoramic sunroof - the first in its category.





Inspiration from high above.

A classic, pale yellow manor house on the shore of Lake Como with a sign bearing the name “Villa Salazar”. What looks like an aristocratic retreat actually houses the Mercedes-Benz Advanced Design Studio – speciality interior design. Around 20 designers, modellers and engineers have been working here since 1998, leaving no stone unturned in their quest to make future Mercedes-Benz models as comfortable and enjoyable as possible for the driver and passengers. It is the perfect environment for our aesthetes: the Como – Milan – Turin triangle

is the hub of the Italian fashion and leather industry, where haute couture meets traditional craftsmanship. For the creative teams, this means exciting experiments with new forms, materials and finishes – and new ideas. And if they need inspiration, they can just look above and around them, as the villa’s ceilings and walls are painted with lavish, baroque frescos. The resulting designs – such as the interior of the C-Class – are timelessly elegant and comfortable, with every last detail perfectly conceived.

Outclasses even the stiffest opposition.

The new C-Class comes loaded with incredible performance, luxury and safety innovations that put it ahead of everything else in its class.



7G-TRONIC

ATTENTION ASSIST

NECK-PRO®

Panoramic Sunroof

PRE-SAFE®

Intelligent Light System

PARKTRONIC
Including Parking Guidance

LED
Day-time running lights

Agility
Control Suspension



It's a C-Class – but not as you know it.

When it exercises restraint, it has the familiar character of a compact-class Mercedes-Benz. Out on the race circuit, it's a different story as its true nature emerges. The C-Class – an unprecedented success story in the DTM.

1988: Mercedes-Benz and the motorsport experts from AMG first entered the DTM, four years young at the time. Lining up at the start was a 190 E 2.5-16 model, a racing version of the famous precursor to the C-Class. Mercedes-Benz promptly took this car to second place in the DTM championship and went on to secure a position on the podium in the years that followed: 1991 and 1993 runner-up, 1992 and 1994 DTM winner with the first genuine C-Class – a triumph repeated in 1995, 2005 and 2006.

The 2010 season was the most successful to date for Mercedes-Benz and AMG: the C-Class took first place in nine out of eleven races and so secured the DTM championship for Paul Di Resta. This triumph proved once and for all that a C-Class should never be underestimated.

transmissions. Comfort. Light. Interior. Following an accident. Total displacement. Multimedia systems. kW at rpm. In the event of danger. Assistance
optional extras. Safe driving. Upholstery. Trim. g/km. Wheels. Services. Nm at rpm. Trim. Dimensions. Following an accident. Paintwork. Petrol engines
Technical data. Rated output. In the event of an accident. Emission class. Top speed. cc. l/100 km. cd value. Standard equipment. Trim. Sustainability
comfort. Following an accident. Interior. Total displacement. Light. Multimedia systems. kW at rpm. In the event of danger. Assistance systems. Seats.
safe driving. Upholstery. Trim. g/km. Wheels. Services. Nm at rpm. Trim. Dimensions. Following an accident. Paintwork. Petrol engines. Technical data
Technical data. Rated output. In the event of an accident. Emission class. Top speed. cc. l/100 km. Standard equipment. Trim. Sustainability. Services. Ac
rpm. l/100 km. Dimensions. Technical data. CO₂. Chassis. Fuel. Fuel consumption. Assistance systems. Seats. Climate control. Equipment packages. Sa
Dimensions. Following an accident. Paintwork. Diesel engines. Transmissions. Comfort. Light. Interior. Following an accident. Total displacement. Multir
imate control. Equipment packages. Total displacement. Safe driving. Upholstery. Trim. g/km. Wheels. Services. The facts. Nm at rpm. Trim. Dimens
rbags. Acceleration. CO₂. Chassis. Fuel. Exterior. Interior. Technical data. Rated output. In the event of an accident. Emission class. Top speed. cc. l/1
ation. Exterior. Diesel engines. Transmissions. Comfort. Following an accident. **The facts.** Interior. Total displacement. Light. Multimedia systems. kW
Equipment packages. Total displacement. Optional extras. Safe driving. Upholstery. Trim. g/km. Wheels. Services. Nm at rpm. Trim. Dimensions. Follo

Drive system & chassis**Safety****Comfort****AMG****Equipment and appointments****Facts & colours****Service & Dealer Network**

28 BlueEFFICIENCY

30 Diesel engines
4-cylinder32 Petrol engines
4-cylinder34 Chassis & suspension
AGILITY CONTROL
suspension36 Transmissions
7G-TRONIC38 Active Safety
Intelligent Light System

40 ATTENTION ASSIST

42 In the event of danger
or an accidentPRE-SAFE® system
NECK-PRO® head restraints
Airbags44 Advanced assistance
PARKTRONIC incl. Advanced Parking Guidance

45 Climate control

46 C-Class Sport Edition

48 C 63 AMG technology

49 AMG Performance Studio

50 C 63 AMG exterior

52 C 63 AMG interior

54 Design and equipment lines,
incl. upholstery and trimAMG PERFORMANCE EDITION
AVANTGARDE
ELEGANCE
CLASSIC

70 Genuine Accessories

84 Paintwork

86 Technical data

87 Dimensions

88 Service

90 Dealer Network

The C-Class in detail.

BlueEFFICIENCY – Fast forward to tomorrow

We are quicker at getting environmentally friendly future technologies to where it matters most: on the road. As the inventor of the motor car, Mercedes-Benz has a special responsibility – one we have undertaken with all our might for many years. By the end of 2011, we will be able to offer you 128 models with BlueEFFICIENCY technologies, all of which help you reduce your impact on the environment – without compromising on safety, comfort and driving enjoyment.

Our BlueEFFICIENCY concept comprises innovations for efficient mobility as well as optimised processes all the way along the value chain. They involve different approaches, but they all have a common goal: to make your individual mobility as sustainable as possible.

The BlueEFFICIENCY measures – the Mercedes-Benz efficiency package. This package consists of comprehensive vehicle optimisations

designed to save fuel and ease the burden on the environment. Each model combines the most efficient engine with latest-generation aerodynamic and energy-management measures to minimise fuel consumption. Such measures include intelligently controlled ancillaries, tyres with optimised rolling resistance, lightweight components and the ECO start/stop function, which is being made available for an increasing number of models. The new BlueDIRECT V6 and V8 petrol engines, which feature in several model series, deliver a much higher power output while reducing fuel consumption by up to 24%.

BlueTEC – the clean diesel. Mercedes-Benz has brought to market BlueTEC technology for diesel engines based on common-rail direct injection (CDI). A modular emission-control system makes BlueTEC an exceptionally clean diesel technology, as not only does it remove up to 95% of the particulate matter from the exhaust gases, it also reduces nitrogen oxides by up to 90%. What remains is mainly water, nitrogen and the satisfying feeling of having helped

to ease the burden on the environment.

HYBRID – petrol and electric drives intelligently combined. A well-established team makes a lot of things easier. And this is certainly true in the case of HYBRID technology. Here the electric motor is used for the recuperation of kinetic energy. This energy is stored in the battery and returned to the electric drive when needed, which assists the petrol engine when the car is accelerating. What's more, the ECU shuts off the petrol engine when the speed is below 15 km/h. In this way, a HYBRID can reduce fuel consumption by up to 20%. So it looks after



The **BlueEFFICIENCY measures** bring about a substantial reduction in fuel consumption and CO₂ emissions.

the environment as well as your bank balance. Perfect teamwork, you might say.

BlueTEC HYBRID – clean diesel combined with electric drive. It marries the benefits of the HYBRID with those of BlueTEC: during braking, the kinetic energy is converted into electrical energy, which can be re-used when required. At the same time, the BlueTEC technology cleans exhaust gases and removes many of the pollutants. All of which makes the economical diesel powerplant even more efficient, agile and clean.



Using the E-Class as a basis, we are developing a diesel hybrid equipped with **BlueTEC HYBRID Technology**.

Innovative drive systems that break new ground. E-CELL and F-CELL. Mercedes-Benz has developed two locally emission-free drive systems known as the E-CELL and F-CELL. The B-Class F-CELL is already being produced on a small scale and has been displaying its everyday practicality on Germany's roads since mid-2010. It uses hydrogen to produce power for the electric motor in a fuel cell. The first vehicles from a small series of the A-Class E-CELL – which features an electric motor that draws its energy from two lithium-ion batteries, giving it an average range of more than 200 km –



The A-Class **E-CELL** allows locally emission-free driving with a battery-powered electric motor.

began rolling off the production line at the end of 2010. An E-CELL PLUS is also scheduled for release, which will include a small internal combustion engine combined with a generator to increase the range of the electric vehicle.

But that is not all: under the banner “Design for Environment”, we also look at a vehicle's entire lifecycle and work hard to preserve the environment from the planning stage right through to recycling. The same applies to the building and running of new plants. In addition, we are heavily involved in the development of alternative fuels and carry out research in the field of bionics. In short, BlueEFFICIENCY is good news for both you and the environment.

Further information about our comprehensive measures can be found at:

www.mercedes-benz.com/blueefficiency

Diesel engine

Cleaner, more powerful and more economical: the C-Class also signals the launch of the latest Mercedes-Benz diesel technology. The powerful and quiet engines impress with their low emission and fuel-consumption figures.

4-cylinder in-line engines. The 4-cylinder diesel unit with a choice of four power outputs displays a high level of sophistication: it offers impressively rich torque and instantaneous response, even at low revs. What's more, the diesel engines consume less fuel, have low emissions and are both quiet and powerful.

This is made possible by a wealth of innovative technologies. Fourth-generation common-rail diesel technology impresses by virtue of an injection

pressure increased to 2000 bar, optimised combustion chambers and extremely precise injectors. Higher ignition pressure and the turbocharger make for high torque in every engine speed range, while the requisite refinement comes courtesy of two Lanchester balancer shafts. Optimised alternator management ensures consistent use of the engine's coasting phases, thus allowing recuperation of kinetic energy. Meanwhile the radiator shutter reduces the aerodynamic drag when

the engines require only moderate cooling. The current engine generation delivers impressive output and high torque as well as reduced fuel consumption and CO₂ emissions.

The current line up includes a powerful C 250 CDI BlueEFFICIENCY engine delivering output of 150 kW / 204 hp @ 4200 rpm & C 220 CDI that delivers output of 125 kW / 170 hp @ 3000-4200 rpm.





C 250 CDI BlueEFFICIENCY

Petrol engines

Mercedes-Benz offers a wide range of environmentally compatible engines. New technologies reduce fuel consumption, while CO₂ emissions are lower than ever for a Mercedes-Benz C-Class.

4-cylinder in-line engines. The optimised 4-cylinder powerplant with a displacement of 1.8 litres, direct petrol injection, variable valve timing and turbocharger offers outstanding torque and power, not to mention appropriately low fuel consumption and emissions. Fuel is used efficiently thanks to almost complete combustion,

while the variable valve timing allows optimum cylinder charging and, therefore, reduces fuel consumption. Fuel consumption is also cut thanks to the reduced weight and low internal friction. Two balancer shafts ensure low engine vibration in every engine speed range.

The 4-cylinder petrol engines come with :

- C 200 BlueEFFICIENCY developing 137 kW and a peak torque of 285 Nm

All engines are exceptionally quiet and meet stringent fuel consumption and emission requirements (Euro 4).





C 200 BlueEFFICIENCY

Agility redefined

The AGILITY CONTROL suspension with selective damping system really comes into its own on the road, offering a high level of comfort as well as impressive agility.

The C-Class has always been known for its outstanding ride comfort. The aim of our engineers was therefore to raise the standard yet again. The C-Class now features a selective damping system. The standard-fit AGILITY CONTROL package

automatically adjusts the dampers at each wheel to a harder or softer setting according to the given situation, ensuring a significantly smoother ride than conventional dampers, particularly on poor road surfaces. If you want to stay relaxed while you're at

the wheel, it is vital to keep interior noise levels low. To eliminate wind noise from the C-Class interior even more effectively, we have optimised the shape of countless bodywork details and further improved the sound insulation.



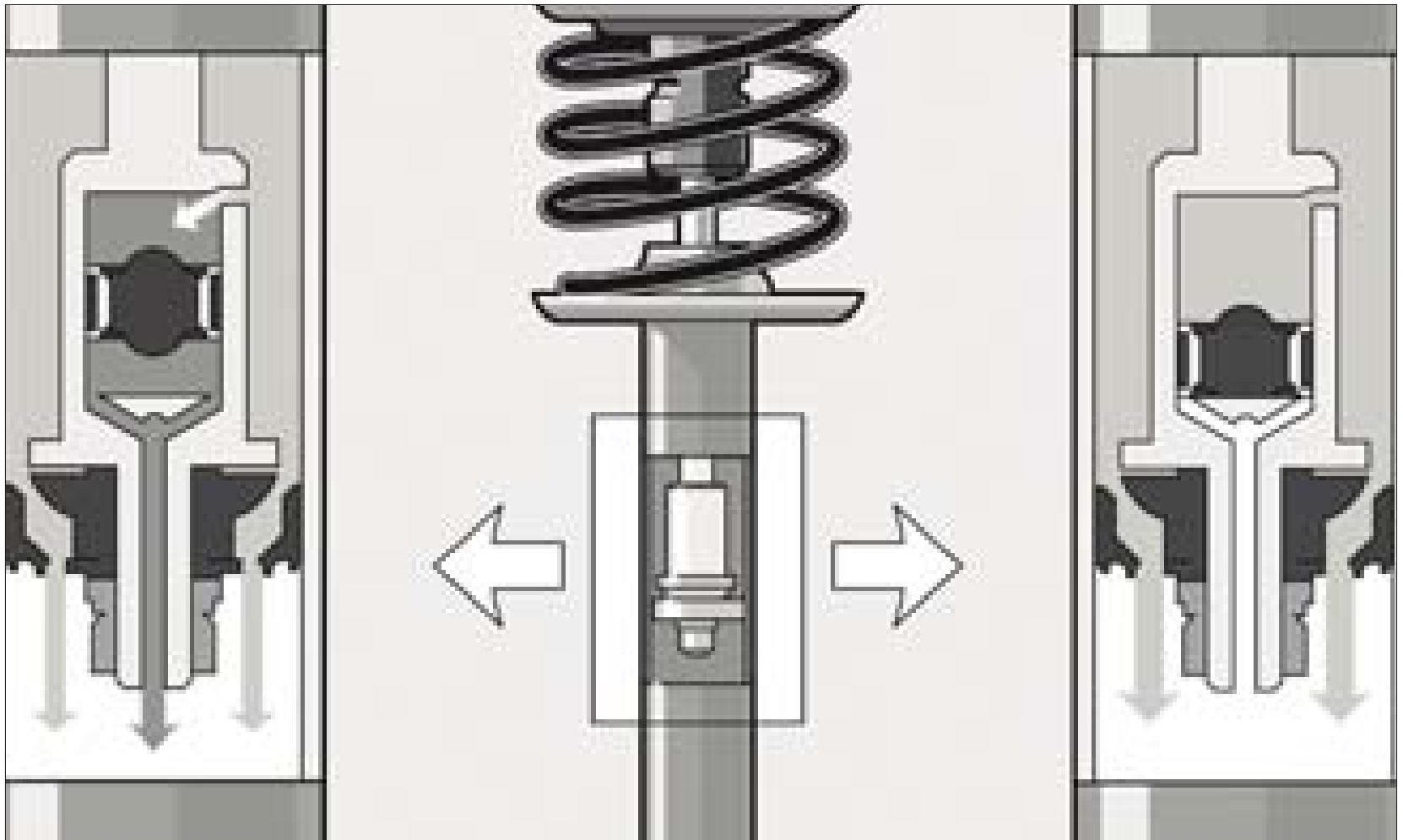

Selective damping system: Softer shock absorber characteristics ensure an extremely smooth ride in normal mode. For dynamic driving the full damping force is made available to stabilize the vehicle.

Transmissions

Whether it be a manual gearshift or an automatic, an economical or a sporty driving style – the transmissions for the C-Class have been optimised in line with the model in which they are installed. Plus they are intuitive and ergonomic to use.

7G-TRONIC. The 7G-TRONIC 7-speed automatic transmission (Petrol and Diesel Engine) setup includes a new torque converter generator which ensures more dynamic response, greater durability, reduced noise levels and significantly lower fuel

consumption. Furthermore, the seven forward gears in the 7G-TRONIC ensure an ideally adapted engine speed at all times, short shift times and smooth shifts. Driving enjoyment is likewise enhanced: the car delivers even better acceleration

and provides even more pulling power. And when changing down, gears can be skipped for fast in-gear acceleration.





7G-TRONIC 7-speed automatic transmission

Intelligent illumination

The C-Class lights the way with Intelligent Light System.

The Intelligent Light System - Adapts headlamp range and light distribution to different conditions and driving situations. This system consists of pivoting Bi-Xenon modules in the headlamp housing with an adjusting mechanism for precise direction of adaptive headlamp beams. The Bi-Xenon modules follow the driver's steering

wheel movements and are able to pivot sideways at once when he enters a bend. **The Cornering lights and Active Light System** come into play to ensure that the bends are illuminated more effectively than before. Additionally, the enhanced fog lamps provide a broader light beam with better light distribution for more effective illumination

of the road verges. The Intelligent Light System operates in two different modes, **Country light mode and Motorway light mode**, and depending on the type of journey adjusts lighting for an increased range of vision.

Other cars without ILS



Other cars without ILS



Other cars without ILS

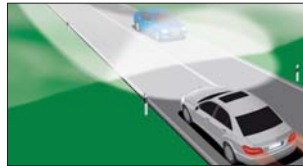

Other cars without ILS



Other cars without ILS



Mercedes-Benz with ILS



Mercedes-Benz with ILS



Mercedes-Benz with ILS



Mercedes-Benz with ILS



Mercedes-Benz with ILS



City Mode

Highway Mode

Fog Mode

Active Curve

Cornering Light

Adaptive Highbeam Assist - Improves visibility at night by only dimming the main beam, just enough, so as not to dazzle oncoming traffic or vehicles in front. The transition from main beam to low beam is almost seamless, meaning that the driver does not perceive any abrupt change in the degree of illumination. It aids the driver to make out the contours of the road easier and faster.

Supplemental Restraint System (SRS)

This feature offers additional protection by performing a range of protective functions.

- Deploys airbags selectively
- Deploys NECK-PRO®
- Tensions seat belts
- Switches off engine and heating
- Unlocks doors

- Lowers side windows by 50 mm
- Activates hazard warning lamps
- Triggers pyrofuse in the fuse box
- Activates crash responsive emergency lighting



Always alert

The assistance systems in the C-Class can intervene before an accident happens: thanks to their awareness, even critical situations can be defused – the ideal basis for relaxed driving.



ATTENTION ASSIST is a first-in-its-class innovation that comes as standard in the new-generation C-Class. This revolutionary feature can detect signs of drowsiness or inattentiveness, and alert the driver in time to prevent an accident.

This is done through a number of sensors that detect and analyse the vehicle behaviour and steering movements. If the system detects certain steering patterns that frequently accompany

drowsiness, it warns the driver visually, via the instrument cluster, as well as acoustically. ATTENTION ASSIST can be activated and deactivated in the main menu of the instrument cluster under “Assistance systems”. When switched on, it is active at speeds between 80 and 180 km/h. ATTENTION ASSIST has the following functions:

- A sensor measures the steering wheel position with an accuracy of 0.1°
- The steering behaviour of the driver is analysed for characteristic steering movements
- In interaction with additional sensors, signs of driver drowsiness and lapses of concentration are detected and an alert is sounded



Helps to detect drowsiness at an earlier stage. ATTENTION ASSIST can remind the driver to take a break.

Safety first

Whether there's the danger of an accident or one can no longer be avoided, the C-Class does all it can to provide better protection for the driver and passengers.



The anticipatory occupant protection system, PRE-SAFE®, can recognise critical driving situations and take preventive measures to protect the occupants.

PRE-SAFE® system. The majority of accidents start long before the actual collision: with a lapse in concentration, poor visibility or an unanticipated hazard. That's where the revolutionary PRE-SAFE® anticipatory occupant protection system steps in, by detecting critical driving situations as they start to arise and initiating measures to protect the occupants as a precaution.

On sensing a potential collision, the PRE-SAFE® system quickly evaluates the situation and triggers preventive measures to protect the occupants. Seatbelts tighten, front passenger seats automatically reposition, side windows close and the tilting/sliding sunroof closing system deploys. If the accident is avoided, the seatbelts are slackened, and the system is straight away ready for action again.

NECK-PRO® head restraints. The crash-responsive NECK-PRO® head restraints can help reduce the risk of whiplash injury by moving forwards and upwards to support the heads of the front occupants at an earlier stage in the event of a rear impact. The flexible side bolsters on the NECK-PRO® luxury head restraints provide additional lateral support for the head.

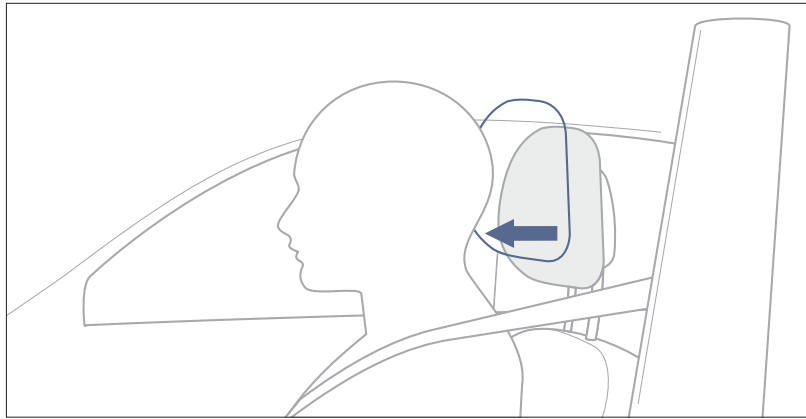

In the event of a rear impact, the NECK-PRO® head restraints can move forwards by 40 millimetres and upwards by 30 millimetres in order to offer added protection.

Airbags. Six air bags are fitted as standard in order to help protect the passengers: front airbags, which can be deployed in two-stages, depending on the accident severity, as well as sidebags and windowbags.

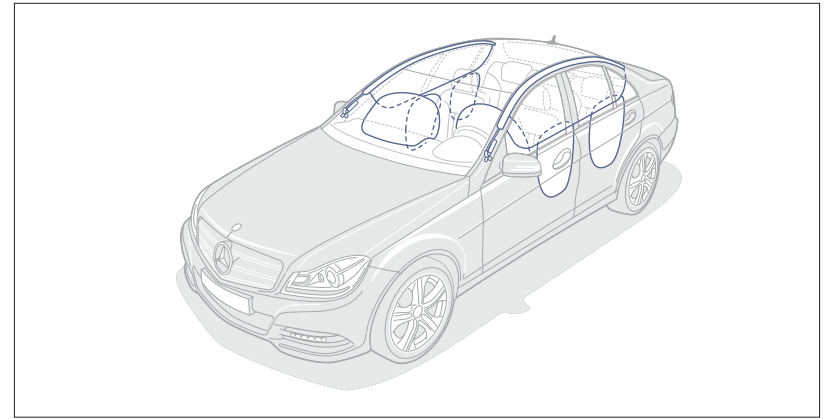

The airbags fitted as standard are part of the restraint systems which are decisive in helping to mitigate the consequences of accidents.

Advanced assistance

The C-Class has always been a car in which convenience has played a major role. And thanks to enhanced assistance systems, such as Parking Guidance, it more than lives up to this reputation.

PARKTRONIC incl. Parking Guidance.

PARKTRONIC can warn the driver automatically if the space in front of or behind the car becomes tight when parking or maneuvering. The system operates on the echo sounder principle, sensors on the front and rear bumpers emit ultrasound

signals, which are then reflected by other vehicles or obstacles. A microcomputer calculates the current distance and informs the driver by means of displays in the instrument cluster and audible signals. Parking damage can therefore be prevented.

Parking Guidance can help the driver when parking and when looking for a parking space: ultrasonic sensors in the side front bumper can measure the length of parking spaces parallel to the car automatically if the car drives past at a speed of 35 km/h or less. Parking Guidance starts once a suitable space has been found and reverse gear has been engaged. It provides the driver with visible and audible instructions regarding the correct steering angle as well as the turn-in and turn-back points on the instrument cluster. If the car is not straight after the first reversing move, the system also helps the driver with the required maneuvering moves.



The display in the instrument cluster gives you a clear picture of what is happening at all times when parking.

Climate control

An ideal interior climate is paramount when it comes to ensuring a high level of driver-fitness and stress-relieving safety. This is why the climate control system for the C-Class is exceptionally versatile and can be adjusted to meet the needs of each individual occupant.



THERMATIC. The THERMATIC automatic climate control system can control the temperature and ventilation for the driver and front passenger automatically. A solar sensor on the windscreen can record the intensity and direction of the sun's rays, for example. Further standard features include air recirculation, a cooled glove compartment and a combination filter which filters out particulate matter. There are two additional air outlets for the rear compartment on the rear end of the centre console.

THERMATIC operates on the basis of sensor information, including data for interior and exterior temperature as well as air humidity.

Thrill meets sportiness.

Start a whole new thrill with the new C-Class Sport Edition. Incorporating outstanding technology, design and materials the C-Class is crafted to lead. The striking masculine exterior of the C-Class now gets a sporty look with the new AMG body styling.

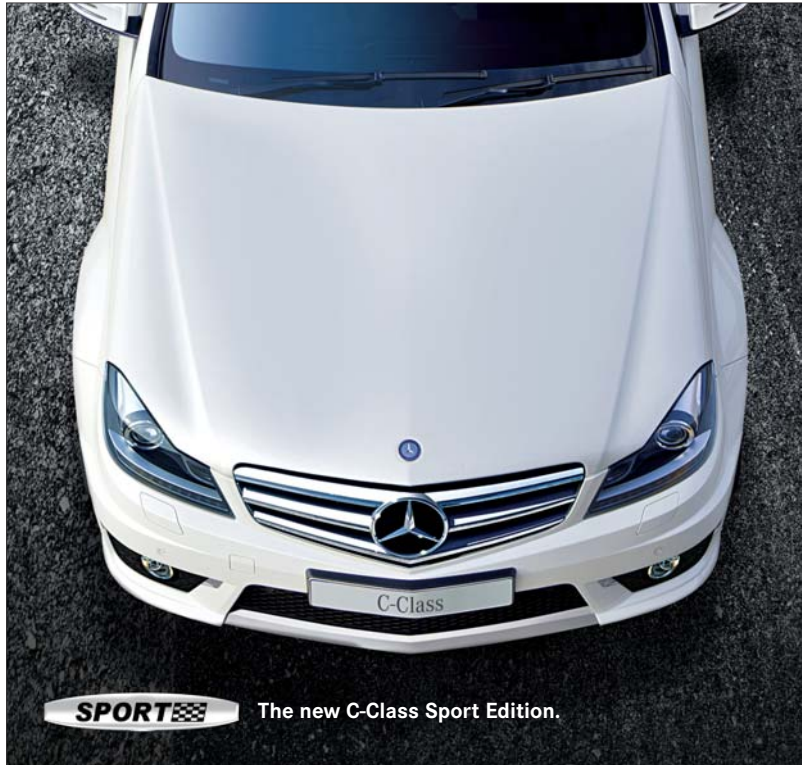



AMG body styling



17" 5 twin-spoke sporty alloy wheels



Black roof

C 63 AMG technology

The AMG 6.3-litre V8 naturally aspirated engine and the AMG SPEEDSHIFT MCT 7-speed sports transmission offer an emotional driving feel and driving dynamics at the highest level. Yet when it comes to choosing a sporty or comfort-oriented driving style, the driver always has the final say in the sports saloon.

The AMG 6.3-litre V8 engine. A high-revving, naturally aspirated engine with thoroughbred motor-racing technology: the vertical arrangement of the intake and exhaust ducts as well as the magnesium variable-intake manifold with two integrated throttle valves ensure optimum charging of the eight cylinders. Further high-tech features include the variable camshaft adjustment, four valves per cylinder, the stiff aluminium crankcase and the low-friction TWAS (twin-wire-arc-spraying) coating used for the cylinder walls. The V8 powerplant develops 336 kW (457 hp) at 6800 rpm, delivering impressive pulling power and a torque of 600 Nm at 5000 rpm. Ideal ingredients for powerful acceleration in every engine speed range, as the driver has over 500 Nm on tap between 2000 and 6250 rpm.

AMG sports suspension. The retuned AMG sports suspension delivers excitement, thanks to increased agility, enhanced lateral acceleration potential and improved overall ride comfort. Together with the new AMG 5-twin-spoke light-alloy wheels with 235/40 R 18 front tyres and 255/35 R 18 rear tyres, the specific three-link front suspension with a wider track, the AMG speed-sensitive sports steering and the three-stage ESP®, it ensures superlative driving dynamics and thrilling driving enjoyment. The AMG speed-sensitive sports steering has an even more direct ratio and, therefore, offers greater steering precision at high cornering speeds. The AMG sport suspension's stiff springs and gas-pressure shock absorbers ensure optimum road feel and minimise body movements. The AMG sports suspension therefore combines

driving dynamics at the highest level with hallmark Mercedes-Benz long-distance comfort – and thus displays the characteristic attributes of a true AMG. The Electronic Stability Program ESP® has been specially adapted in line with the high level of driving dynamics, as it allows the driver to select the level of assistance provided by the dynamic handling control system by choosing one of three different control settings: ON, SPORT or OFF. The activated setting is shown on the AMG instrument cluster's central display. The AMG high-performance braking system featuring large, internally ventilated and perforated brake discs ensures good levels of deceleration and fade resistance. Not to mention perfect brake control and short stopping distances.

AMG Performance Studio



The AMG Performance Studio offers a range of options for further enhancing the dynamic aspects of the C 63 AMG. A prime example of this is the AMG Performance Package, which boosts the output by 22 kW to 358 kW (487hp) and also includes a variable intake manifold painted in titanium grey, the AMG high-performance composite brake system with compound front brake discs, red-painted brake calipers, the AMG carbon-fibre



spoiler lip on the boot lid, and the AMG Performance steering wheel in nappa leather/Alcantara®. Options available separately include AMG carbon-fibre trim, the AMG Exterior Carbon-Fibre package, AMG door sill panels with white LED illumination and the AMG rear-axle differential lock. AMG multi-spoke light-alloy wheels in titanium grey or matt black, or 5-spoke light-alloy wheels in titanium grey, also available as optional extras,



emphasise the unique appearance of the C 63 AMG. The AMG Driver's package allows an electronically governed top speed of 280 km/h and includes participation in driving training at the AMG Driving Academy. What's more, the AMG Performance Studio can meet customer requests for personalised vehicles as well as special one-off models.



C 63 AMG exterior

The expressive exterior of the C 63 AMG reflects its inner values perfectly: the sporty saloon developing 336 kW (457hp) features an AMG front and rear apron, side sill panels, and flared front wings. The updated look includes features such as the unique AMG LED daytime driving lights, the front apron with a high-gloss black cross-strut, the new radiator grille with a chrome louvre and the unique AMG bonnet with new powerdomes.

www.mercedes-amg.com

EXTERIOR

AMG 5-twin-spoke light-alloy wheels, painted titanium grey with a high-sheen finish, with 235/40 R 18 front tyres and 255/35 R 18 rear tyres

AMG body styling, consisting of front apron with side air outlets, side skirts and diffuser-style rear apron

AMG high-performance braking system with 360 x 36 mm front brake discs and 330 x 26 mm rear brake discs

AMG spoiler lip on the boot lid

AMG sports exhaust system with two chromed twin tailpipes

Distinctive, flared front wings with “6.3 AMG” lettering

Tail lights with LED technology

Unique AMG bonnet with new powerdomes

Unique AMG front apron with cross strut in high-gloss black

Unique AMG LED daytime driving lights

Unique AMG radiator grille with a single chromed louvre

C 63 AMG interior

Inside, too, the C 63 AMG impresses with sporty touches throughout. At the heart of the interior is the new AMG tube-design instrument cluster with a colour display and the AMG Start-up indicator as well as the three-spoke AMG Performance steering wheel trimmed in nappa leather and featuring perforations in the grip area, silver-coloured aluminium shift paddles and flattened top and bottom sections. Exclusive, ergonomic AMG sports seats with ARTICO man-made leather upholstery in black as standard (optionally available in single- or two-tone designo leather) ensure excellent seating comfort. A black roof lining, dark brushed-aluminium trim and brushed stainless steel AMG door sill panels and AMG sports pedals complete the dynamic ambience.

INTERIOR

AMG door sill panels in brushed stainless steel

AMG instrument cluster, incl. RACETIMER and AMG Start-up indicator

AMG Performance steering wheel in nappa leather, with flattened top and bottom sections as well as silver-coloured aluminium gearshift paddles, incl.

AMG speed-sensitive sports steering

AMG sports seats in ARTICO man-made leather in black

New rotary switch for selecting the four transmission modes and the Race Start function

Brushed stainless-steel sports pedals with rubber studs

Dark brushed-aluminium trim

AMG sports suspension







AMG PERFORMANCE EDITION

The AVANTGARDE with AMG Performance Edition now offers an extra edge to the already sporty look of the C-Class. Aggressive exterior and contrasting interiors keep you wanting more and more from your favourite brand.

EXTERIOR

AMG Body Styling (front and rear apron & side sill panels)

AMG Sports Package

17-inch 5-twin spoke light AMG alloy wheels

INTERIOR

Aluminium-look gearshift/selector level with leather gaiter

Brushed stainless steel AMG Sports pedals with black rubber studs

Dynamic Handling Package

Black Ash Wood trim

Leather upholstery





The upholstery is trimmed in genuine leather and the high-quality interior is trimmed in the selected colour. The brushed aluminium trim emphasises the sporty ambience.

BLACK

221 Leather

CAPPUCCINO

224 Leather

SAHARA BEIGE

235 Leather

TRIM

739 Brushed aluminium

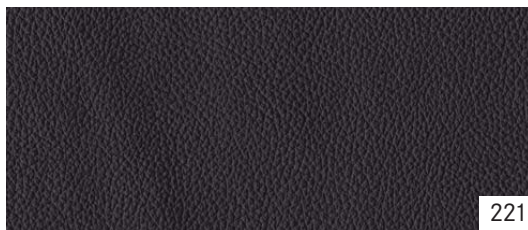

221



224



235



739



739



739



AVANTGARDE

The AVANTGARDE lends the C-Class a distinctly sporty character. The exterior is more dynamic, more striking and bolder, while colour contrasts in the interior add dynamic touches.

EXTERIOR

Panoramic Sunroof

LED day-time running lights

Headlamps cleaning equipment

Headlight unit with Intelligent Light System

17-inch 5-twin spoke light alloy wheels

INTERIOR

Leather upholstery

Front seats electrically adjustable with memory package

Multi-function steering wheel (12 buttons)

PARKTRONIC including Parking Guidance

Audio 20 with 6- CD changer

Media interface

Aluminum trim

ATTENTION ASSIST





The upholstery is trimmed in genuine leather and the high-quality interior is trimmed in the selected colour. The brushed aluminium trim emphasises the sporty ambience.

BLACK

221 Leather

CAPPUCCINO

224 Leather

ALPACA GREY

228 Leather

SAHARA BEIGE

235 Leather

TRIM

739 Brushed aluminium



221



224



228



235



739



739



739



739



ELEGANCE

The ELEGANCE emphasises the elegant side of the C-Class. Exterior features that catch the eye right away include the polished chrome highlights, while the harmonious interior features an impressive mix of fine trim and a discreet tone-in-tone colour concept.

EXTERIOR

Electric sunroof in glass version

LED day-time running lights

Headlamps cleaning equipment

Headlight unit with intelligent light system

17-inch 7-twin spoke light alloy wheels

INTERIOR

ARTICO man-made leather upholstery

Multi-function steering wheel (12 buttons)

PARKTRONIC including Parking Guidance

Front seats electrically adjustable with memory package

Audio 20 with 6- CD changer

Media interface

Burr walnut wood trim

ATTENTION ASSIST





The ARTICO man-made-leather upholstery can be specified in black, almond beige or alpaca grey and combined with a fine-grained burr walnut wood trim. The dashboard, inside of the doors and carpets match the selected interior colour perfectly.

BLACK

121 ARTICO man-made leather

SAHARA BEIGE

135 ARTICO man-made leather

TRIM

731 Brown burr walnut wood

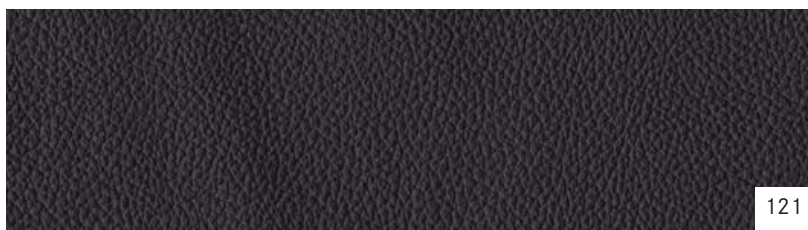

121



135



731



731



CLASSIC

The Classic offers classic, traditional design of C-Class line-up, dynamically shaped headlamps & visual Interplay between matt & high-gloss areas further accentuate the V-shape exteriors. Interiors get classy with a redesigned cockpit, elegantly styled centre & dashboard console.

EXTERIOR

Halogen lamps

Tail lights with LED technology, LED third brake light

Electrically adjustable exterior mirrors with clear glass indicators

16-inch 7-spoke light alloy wheels

INTERIOR

Fabric upholstery

Multi-function steering wheel (12 buttons)

Audio 20 CD player

Sunblinds for rear doors

Windscreen wipers with rain sensors and one-touch wipe function





The Fabric upholstery can be specified in Alpaca Grey & Black combined with black lacquer piano Trim element

BLACK

121 Fabric Upholstery

ALPACA GREY

128 Fabric Upholstery

TRIM

H80 Black Lacquer Piano

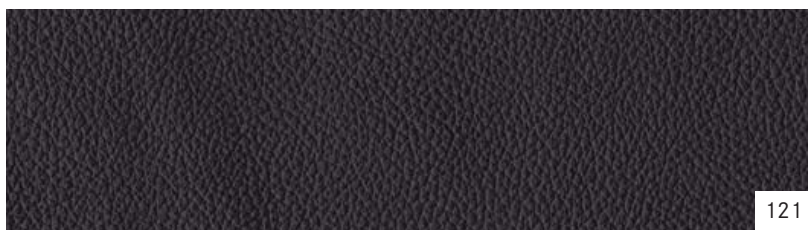

Genuine Accessories

Mercedes-Benz Genuine Accessories help add dynamic, stylish, top-quality extra touches to the C-Class, thereby creating an individual look for the C-Class.

Illuminated Star - Using fibre-optics and LED technology the central star on the radiator grill of your Mercedes illuminates when you lock or unlock the car with your remote or when you open a door or the boot lid. *Only functions when engine is switched off.



Illuminated Star

iPad® Docking Station Plus for rear compartment The ergonomic, crashproof Docking Station introduces the iPad® and all of its familiar functions to your Mercedes-Benz. All connections, e.g. for your headphones, remain accessible. The mount can be tilted and rotated around 90°. An integral USB port means you can also charge your iPad®'s battery using your charging cable. Suitable for iPad®, iPad® 2, iPad® 3 and iPad® 4.



iPad® Docking Station Plus for rear compartment

Rear Seat Entertainment system This elegant DVD system allows the rear passengers to watch DVDs, look at their favorite pictures and even play video games on two superb 17.8 cm screens with TFT technology, without disturbing the driver or restricting the rear field of vision. Rear-seat passengers have the option of watching a different video on each screen, allowing each to select their own individual entertainment. The AV-IN connection and USB and SD card interfaces allow other storage media to be used too. Supplied with two sets of infrared headphones and remote control. A separately available video cable allows users to watch videos or view images from external sources. Also available in single screen.



With a range of multimedia connections, 2 sets of infrared headphones and a remote control, the Rear Seat Entertainment System offers everything you need for in-car entertainment.

Genuine Accessories

Styling

Front apron spoiler lip Emphasizes the width of the vehicle and lowers the visual focus at the front end. Made from dimensionally stable polyurethane, with high-quality primed finish. Available in primed condition and can be painted in the required colour by your Mercedes-Benz Dealership.



Front apron spoiler lip

Roof spoiler Elongates the roof line and gives the rear of the vehicle a more dynamic and sporty look. Does not affect field of vision in rear-view mirror. High-quality primed finish allows product to be painted in required colour. Highly durable thanks to precision-fit, dimensionally stable polyurethane. Straightforward fitting – no need for additional drilling.



Roof spoiler

Rear spoiler Discreet spoiler, fitted to the boot lid, subtly accentuating the rear contours of the Saloon. High-quality primed finish allows product to be painted in required colour. Highly durable thanks to precision-fit, dimensionally stable polyurethane. Straightforward fitting – no need for additional drilling.



Rear spoiler

Rear apron trim with diffuser-look High-quality primed finish – ideal for painting in desired colour. Makes the rear of the vehicle appear broader and lower-slung and underlines the car's dynamic looks. Highly durable thanks to precision-fit, dimensionally stable polyurethane.



Rear apron trim with diffuser-look

High-gloss black exterior mirror housing For an individual, sporty and dynamic look. Set of 2.



High-gloss black exterior mirror housing

High-shine chromed door handle recesses Round off your vehicle's chrome finish and protect the paintwork from scratches. Straightforward fitting – no need for additional drilling.



High-shine chromed door handle recesses

Sports pedals in brushed stainless steel A distinctive touch: elegant brushed stainless steel and non-slip rubber studs signal sporting ambition.



Sports pedals in brushed stainless steel

Illuminated Door Sill Panels The blue illuminated Mercedes-Benz lettering is activated every time you open the door to get in or out. These illuminated door sill panels, in ground stainless steel, are a further “highlight” of the C-Class.



Illuminated Door Sill Panels

Genuine Accessories

AMG - A sporty exterior for your C-Class. The AMG bodystyling components – front apron, rear apron and side skirts – are designed for optimum dynamism.

AMG front apron



AMG front apron

AMG rear apron



AMG rear apron

AMG side skirts



AMG side skirts

AMG door sill panels, illuminated In brushed stainless steel. Set of 4 with white LED illumination (only front panels are illuminated).



AMG door sill panels, illuminated

AMG floor mats Short loop pile design, set of 4-piece, black, with embroidered AMG lettering.



AMG floor mats

AMG door pin In high-quality stainless steel.



AMG door pin

Genuine Accessories

Protection and Care

Quickpark The Quickpark parking assist system is ideal at places where space is limited. The system is automatically activated when reverse gear is engaged. It is based in ultrasonic technology: ultrasonic signals are bounced back off obstacles in their path, and the distance between the vehicle and the obstacle is indicated by an audible warning signal.



Quickpark

Mud flaps Protect the underbody and the sides of the vehicle from loose chippings and dirt. Available in pairs for front or rear axle. Primed. Can be painted in body colour by dealer.



Mud flaps

CLASSIC all-season floor mats Robust, washable synthetic mats, designed for heavy use. Curved line design. With distinctive Mercedes-Benz star logo. Available in black.

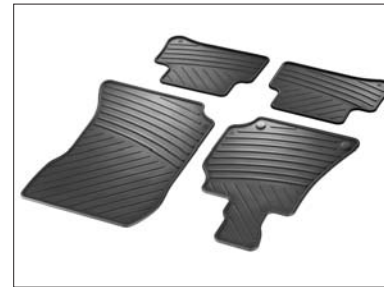

CLASSIC All-season floor mats

CLASSIC Rep floor mats Durable, extremely hardwearing needle felt mats, featuring metal badge with Mercedes-Benz lettering. Available in various colours to match your interior. No need for additional drilling.



CLASSIC Rep floor mats

Genuine Accessories

Light-Alloy Wheels

Mercedes-Benz light-alloy wheels not only boost your vehicle's looks, they also offer the ultimate in safety. All wheels are precision-tailored to your vehicle in terms of load profile and dimensions. Before your light-alloy wheels are allowed to accompany you safely on your travels, they are subjected to an extensive development and testing programme. Each wheel design has to pass a variety of endurance tests, based on exacting Mercedes-Benz guidelines, all of which exceed statutory requirements. Only once all of the tests have been passed may the wheels be included in the range of genuine Mercedes-Benz light-alloy wheels.



MB 5-spoke wheel Finish: titanium silver
Wheel: 7.5 J x 17 ET 47 | Tyre: 225/45/R17
A20440160027X07



MB 7-spoke wheel Finish: chrome shadow
Wheel: 7.5 J x 17 ET 47 | Tyre: 225/45/R17
A20440169027X29



MB multi-spoke wheel Finish: titanium silver
Wheel: 7.5 J x 17 ET 47 | Tyre: 225/45/R17
A20440112029765



AMG 5-spoke wheel Finish: titanium grey
Wheel: 8 J x 18 ET 45 | Tyre: 225/40/R18
B66030098



AMG 7-twin-spoke wheel Finish: high sheen, black
Wheel: 7.5 J x 18 ET 47 | Tyre: 225/40/R18
B66031509



Mercedes-Benz Hub Caps provides a stylish finish for light-alloy wheels. It is not just attractive but practical too as the caps keep the hubs clean. There are plenty of options available to choose from various designs available to suit Mercedes-Benz vehicles.

Genuine Accessories

Cargo & Care

Stowage crate A secure hold for items which are prone to tip over or slide around, e.g. shopping bags. Adjustable partitioning elements allow crate to be divided into max. four sections. Optimum functionality only in conjunction with shallow boot tub.



Stowage crate

Shallow boot tub Made from impact-resistant, non-slip polypropylene. Suitable for transporting foodstuffs. Structured surface holds separately available stowage crate in place.



Shallow boot tub

Non Slip Mat Everything stays where it should be – thanks to the non-slip mat. Plastic studs prevent the load from sliding around and causing damage. The shape is optimally tailored to the contours of the load area. The material speaks for itself: 100% polyester, hence oil and acid-resistant. Practical: easy-clean and washable. No condensation.



Non Slip Mat

Concertina load sill protector Protects the rear of the vehicle from scratches when you're loading the vehicle – and prevents dirt from the car from getting onto your clothes. Practical design – can be secured to shallow boot tub or reversible mat.



Concertina load sill protector

Luggage Net For a tidy and uncluttered interior. Versatile and, once fitted, indispensable: the luggage nets are available in various sizes, most taking the form of a pocket. They are designed to secure small items and lightweight objects in place, preventing damage during transport. All-round flexibility: the black stretch nylon net hugs the contents and has a high capacity.



Shopping crate

Tie Down Straps A reliable accessory for your travels. The adjustable tie-down strap for everyday use on board. Designed to secure objects in place and prevent them from sliding around. You'll be impressed every time at how easy it is to use.



Tie Down Straps

Genuine Accessories

Other Accessories

Coolbox Not only cools but warms too. Cools to up to 20°C below ambient temperature – to max. -2°C. Can be switched to warming function. Robust, highly insulated hard case with fabric cover, outside pockets and padded shoulder strap. Capacity: 24 litres. Can be connected to 12 V socket in vehicle or to 230 V power source via separately available rectifier.



Coolbox

Rectifier Allows the coolbox to be connected to a 230 V socket at home.



Rectifier

Coat hanger Minimize creasing with this stylish and practical coat hanger made from chromed metal. Easy to fit to the front head restraints.



Coat hanger

Tyre pressure gauge Allows you to carry out a quick tyre pressure check on the road or at home. Keeping tyres at the optimum pressure saves fuel and reduces tyre wear. Suitable for all motor vehicle tyre valves and for cycle valves. Supplied with leather pouch.



Tyre pressure gauge

The vario bag A simple way to achieve a tidy interior. The washable vario bag with its open and closed compartments lets you pack everything away tidily, within easy reach and is simple to attach to the head restraints. A neat side-effect: the vario bag protects the backs of the front seats from dirt and muddy footprints.



vario bag

Additional interior mirror Greater visibility for enhanced safety: the additional interior mirror extends your field of vision inside the car, allowing you to keep an eye on children, for example, or breakable objects on the rear bench without having to turn round. The function and positioning of the standard interior mirror are not affected – the product is simply snapped into place on the existing mirror. It is made from high-quality, shatterproof mirror glass.



Additional interior mirror

Genuine Accessories

Mercedes-Benz Child Safety

Mercedes-Benz child seats offer optimum protection in the event of an accident. Child seats are tested and inspected to exacting Mercedes-Benz specification.

“BABY-SAFE plus II” child seat Deep, moulded seat design offers extra side-impact protection for optimum safety. Special padding, designed to protect particularly vulnerable body areas of children up to around 15 months (up to 13 kg).



“BABY-SAFE plus II” child seat

“DUO plus” child seat Optimum safety for children between the ages of around 8 months and 4 years (9 to 18 kg). Fitted as standard with top tether, an additional belt for securing the head section, a height-adjustable shoulder belt, ventilation channels and ISOFIX attachment.



“DUO plus” child seat

“KIDFIX” child seat Booster seat for optimum side-impact protection, with height adjustable backrest. The “KIDFIX” seat is secured using the 3-point seat belt and ISOFIX attachment points. For children between the ages of around 3.5 and 12 (15 to 36 kg).



“KIDFIX” child seat



Paintwork

The innovative paint system developed by Mercedes-Benz includes one of the best clear coats on the automotive market and is a key factor behind the car's excellent value retention. The secret lies in the exceptionally dense molecular structure, which makes both the metallic and the non-metallic clear coats more resistant and produces a longer-lasting and visibly more intensive shine.



NON-METALLIC PAINTS (standard)

149 polar white

METALLIC PAINTS (optional)

197 obsidian black

526 dolomite brown

792 palladium silver

775 iridium silver

NON-METALLIC PAINTS

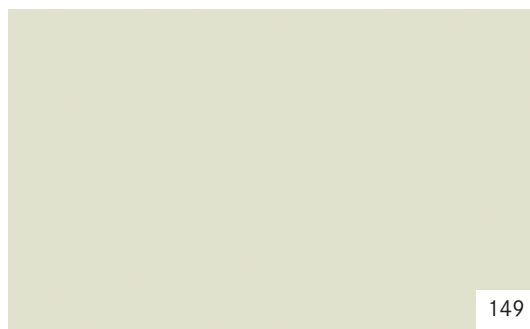

149

METALLIC PAINTS

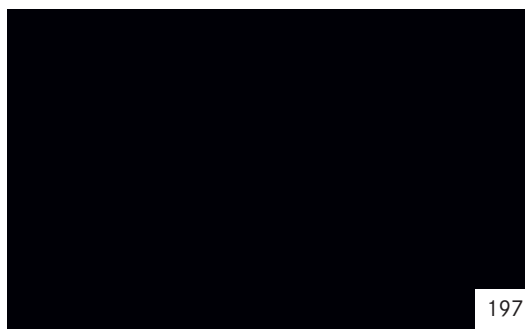

197

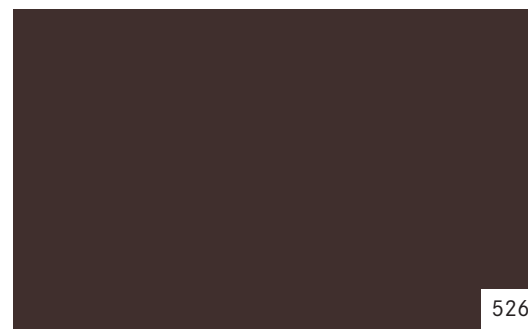

526



792

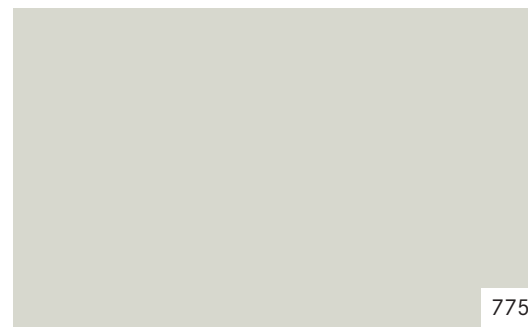

775

Technical data

Technical Specifications

	C 250 CDI	C 220 CDI	C 200	C 63 AMG
No. & arrangement of cylinders	4/in-line	4/in-line	4/in-line	8/V
Total displacement	2143	2143	1796	6208
Rated Output (kw/hp @ rpm)	150/204 @ 4200*	125/170 @ 3000-4200*	137/186 @ 5600*	336/457 @ 6800*
Rated Torque (Nm @ rpm)	500 @ 1600-1800*	400 @ 1400-2800*	285 @ 2400-4000*	600 @ 5000*
Compression ratio	16.2:1	16.2:2	9.3:1	11:3:1
Tyre Size (Front/Rear)	225/45 R 17	205/55 R 16	225/45 R 17	235/40 R 18
Fuel	Diesel	Diesel	Petrol	Petrol
Tank Capacity (l) / including reserve approx.	66/8	66/8	66/8	66/14
Boot Capacity (l)	475	475	475	475
Turning circle diameter (m)	10.84	10.84	10.84	11.10
Kerb weight (kg)	1655	1610	1585	1730
Permissible Gross vehicle weight (kg)	2120	2115	2020	2185
L x W x H	4596 x 1770 x 1447	4596 x 1770 x 1447	4596 x 1770 x 1447	4596 x 1770 x 1447

kW: kilowatt

* As per ARAI certification

Dimensions

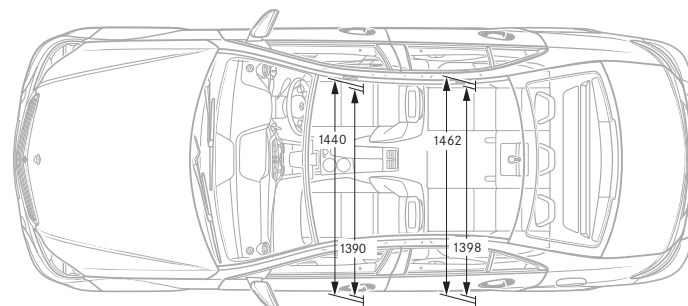
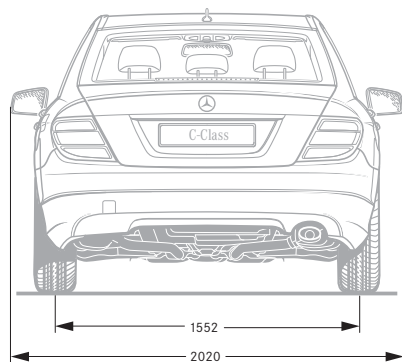
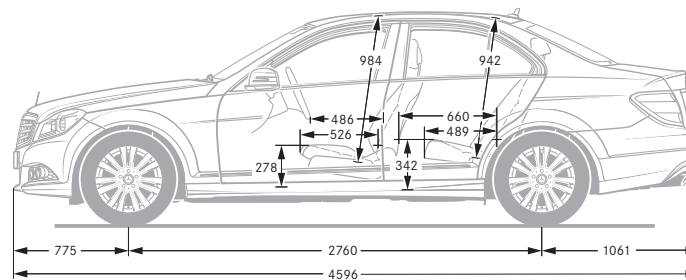
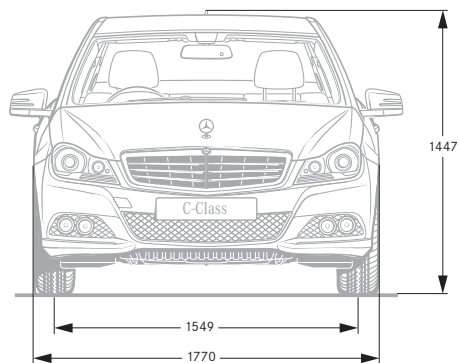

Service

The luxurious experience of driving a Mercedes-Benz is converted into a fulfilling ownership experience with a range of exclusive services and special programmes.

Cost of Ownership

There has been a paradigm shift in the buying preferences of Indian consumers over the years, even for the luxury products. The purchase decision not only dwells around cost of acquisition but also the total 'Cost of Ownership' (COO). Amongst the key components of COO in cars are the routine service jobs and the unplanned repair expenses post

the warranty period. We are now offering highly affordable Service Packages and Extended Warranty Programmes which are the most competitive packages in its class. All in all, we provide you with a controlled Cost of Ownership while you benefit from the legendary Mercedes-Benz service quality.



Experience complete peace of mind when you drive the Star

STAR CARE programme offers peace of mind drive for you during warranty period and beyond. While our cars are covered for warrantable repairs up to 3 years without any mileage limitations, as standard, you can also buy STAR CARE Plus programme, offering 4th year extended warranty. Additionally,



Extended Warranty that guarantees complete peace of mind

the programme enhances the resale value of your car.

STAR EASE Service Package gives you the freedom to relax behind the wheel and puts your mind at ease with its range of unique benefits such as defined cost of maintenance and priority handling. STAR EASE Comprehensive package covers essential jobs related to periodic service (viz. oil, filters, consumables, etc.) along with



The maintenance of your Star is just as peaceful as driving it

coverage for brake pads, brake discs, wiper blades and wheel alignment & balancing, for a contracted period. For further details on products and pricing, please contact your nearest Mercedes-Benz dealer.

On-Road Assistance Programme As part of our ongoing commitment to you, Mercedes-Benz On-Road Assistance is designed to enhance your overall Mercedes-Benz ownership experience by

providing you with 24 hour On-Road Assistance. Mercedes-Benz is the only Luxury car manufacturer to offer round-the-clock On-Road Assistance for **3 years** from purchase of vehicle as a **standard offering**. Peace of mind motoring – guaranteed.



Always at your service

Conditions apply.

Dealer Network

SHOWROOMS:

NORTH & EAST:

DELHI: T & T Motors:

Mohan Co-operative, Mathura Road:

011-26821005/6, 011-66574300;

Rajouri Garden: 011-66574400-01,

011-41022304/05/06;

Gurgaon: 0124-4263060-62;

Jaipur: 0141-4300000-01.

NOIDA: Silver Arrows:

0120-4904400.

PUNJAB & CHANDIGARH:

Joshi Autozone:

Jalandhar: 0181-5004444;

Ludhiana: 0161-5055000;

Chandigarh: 0172-5050500.

KARNAL: Berkeley Motors:

0184-3300000.

LUCKNOW: Smart Hoops:

0522-4924333.

KOLKATA: Benchmark Interkrafts:

033-40686100/109.

WEST:

MUMBAI: Auto Hangar:

Prabhadevi: 022-66123820;

Andheri: 022-66123824;

Metro Motors Auto Hangar division

(Hughes Road): 022-66123827;

Shaman Wheels:

Off BKC: 022-67166666;

Navi Mumbai: 022-27849999,

022-27830066/67.

NAGPUR: Auto Hangar:

07104-238180.

PUNE: B. U. Bhandari:

020-67212121.

NASHIK: Indisch Motoren:

0253-6645555.

GOA: Counto Motors:

0832-2415122, 0-8805778805.

Benchmark Cars:

AHMEDABAD: 079-66185555;

SURAT: 0261-6695555;

VADODARA: 0265-6192525;

INDORE: 0731-6675555;

RAJKOT: 0281- 6699000.

RAIPUR: Auto Hangar:

0-8108123517, 0-9223540191.

SOUTH:

CHENNAI: Trans Car:

044-33570000.

BANGALORE: Sundaram Motors:

080-22070720/21;

Akshaya Motors: 080-22966300.

COIMBATORE: Sundaram Motors:

0422-2452020.

COCHIN: Rajasree Motors:

0484-2706332/2706432.

TRIVANDRUM: Rajasree Motors:

0471-2380377.

HYDERABAD: Mahavir Motors:

040-43403004.

VIJAYAWADA: Mahavir Motors:

0866-2082559, 0-9885303004.

AUTHORISED SERVICE STATION:

DELHI: Patel Auto Services:

Rajendra Place: 011-47626262,

0-9810081048.

AUTHORISED SERVICE CENTRES:

WEST:

AURANGABAD: B. U. Bhandari:

0240-6452601/02/03.

KOLHAPUR: B. U. Bhandari:

0230-3290466, 0-9423041015.

SOUTH:

MADURAI: Sundaram Motors:

0452-2320433, 9940198449.

MANGALORE: Sundaram Motors:

0824-2275779, 0-9900236305.

CALICUT: Rajasree Motors:

0495-2767155, 0-9539075613.

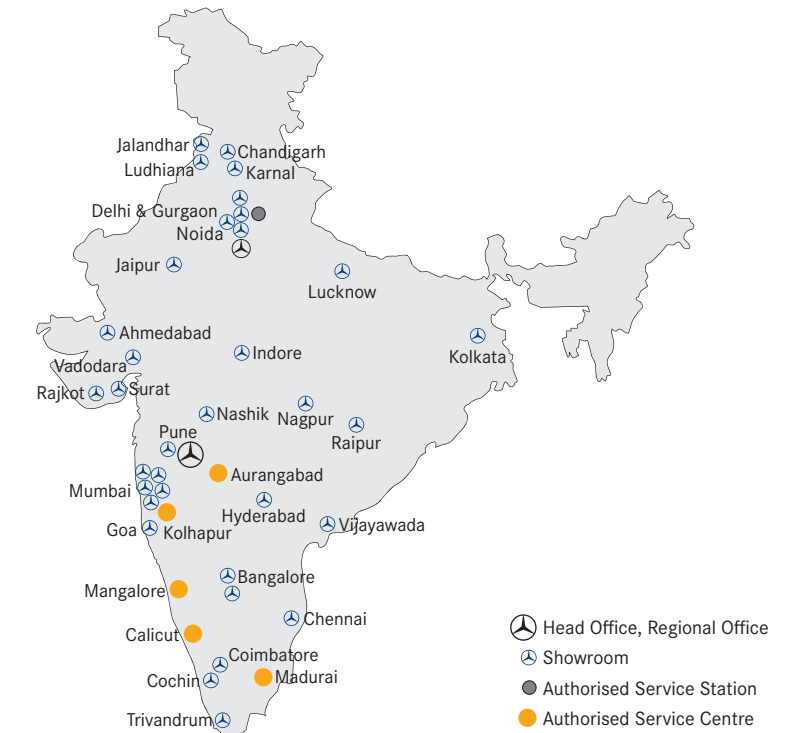

Mercedes-Benz India Private Limited: E-3, MIDC Chakan - Phase III, Chakan Industrial Area, Kuruli & Nighoje, Tal: Khed, Pune - 410 501 (India)

Toll free No.: 1800 102 9222. e-mail: CustomerConnect@Daimler.com, **website: www.mercedes-benz.co.in**

Please note: The information given in this brochure should be regarded as accurate at the time of going to print. The illustrations may show items of optional equipment which are not part of the standard specification. Colours may differ from those shown in the brochure, owing to printing. The manufacturer reserves the right to make changes to design, specification and colours without prior notice.

Month of going to press: October, 2013. Mercedes-Benz cars: series W 204 meets Bharat Stage IV equivalent emission norms.