



MONTERO

Mastery. Beyond the road.

IN A WORLD WHERE THERE ARE
PAVED ROADS AND UNPAVED PATHS,
THE MONTERO MAJESTICALLY ADAPTS ITSELF.



MONTERO WAS **BORN RACING** WHERE ROADS ARE JUST A RUMOUR.
GO **FIND OUT** WHAT EVERYONE ELSE IS MISSING.



ON A **MAP**, THE WORLD **LOOKS FLAT.**

IN REALITY, THINGS GET **A LOT MORE** INTERESTING.

WITH UNBEATABLE **ALL-WHEEL TRACTION,**

MONTERO LIVES IN THREE DIMENSIONS.

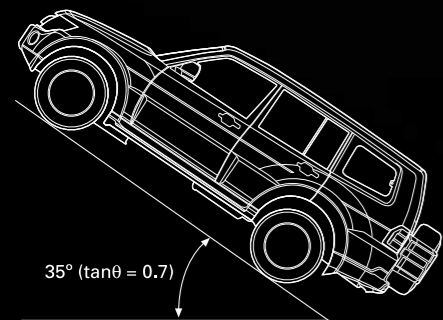

35° (tanθ = 0.7)

Shifting into 4LLc mode gives maximum climb angle of 35°.

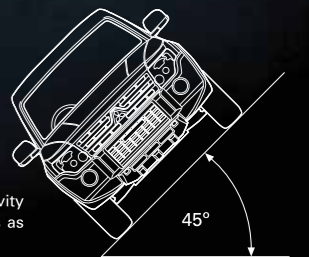

Montero's low centre of gravity lets you travel along slopes as steep as 45°.

ROCKS, RIVERS, MUD AND SNOW.
 WHAT FUN IS GETTING THERE WITHOUT **A CHALLENGE?**



FOUR-WHEEL INDEPENDENT SUSPENSION AND IMPROVED WADING DEPTH.

TAKE MONTERO **OVER, AROUND AND THROUGH**
 EVEN THE TOUGHEST TERRAIN.

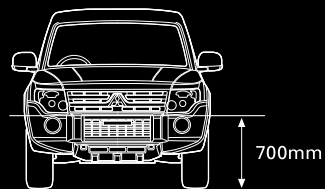

Montero's improved 700mm wading depth opens up territory once off-limits.

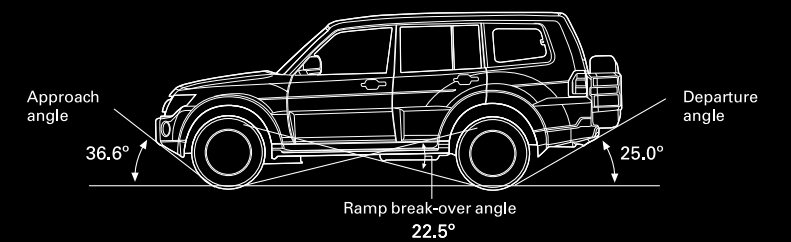

THE BEST OF BOTH WORLDS

Off-road is fun, but there's nothing wrong with looking good downtown, either. From the powerful front grill design to the spare tire cover built directly into the tailgate, Montero has a style that will turn heads for all the right reasons.



DISCHARGE HEADLAMP CLUSTER

Montero uses xenon-gas discharge headlamps that produce twice as much light as ordinary halogen lamps, improving your view of the road and making you more visible to other drivers.

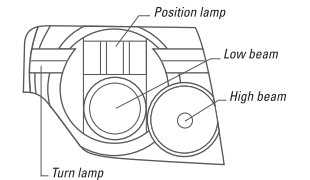

DOOR MIRROR LAMPS

The door mirrors feature built-in turn lamps and approach lamps for added visibility and safety. The approach lamps can be used when getting in or out.

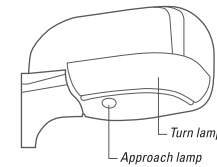

IMPROVED REAR VISIBILITY

The tailgate now has four lamps: one pair of combination tail lamps, plus a high-mount stop lamp above the rear window and a rear fog lamp built into the license plate garnish. In addition, the spare tire has been positioned at lower centre to improve visibility for the driver.

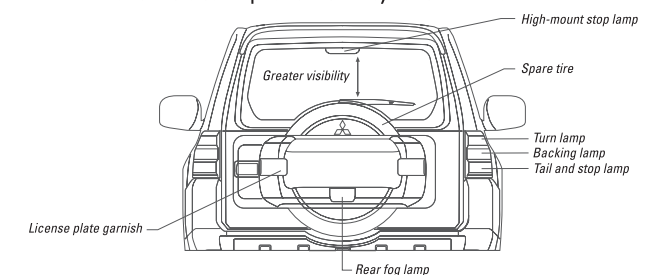

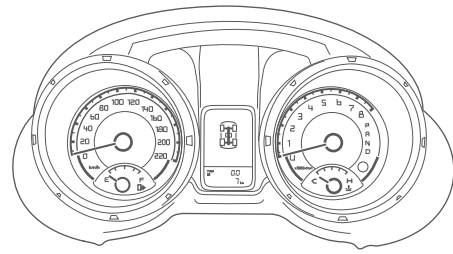

MAN-MACHINE INTERFACE

Comfortable and inviting, the interior of Montero is a far cry from the terrain it was designed to face. Illuminated meters and leather-wrapped controls are all ergonomically arranged and awaiting your command, while the soft leather seats and luxurious appointments throughout tempt you to forget your destination and simply keep driving.





WARM ELEGANCE

Bright as a desert morning, the beige leather casts the interior in a soft, refined glow that beckons you inside.



COOL SPORT

Sleek and mysterious, the black leather interior slips easily into the spotlight, enveloping you in sophisticated comfort.



FLEXIBLE UTILITY SPACE

Every day brings new destinations, new friends, and new adventures. You don't want to be stuck in someone else's rigid assumptions of where to go and what to do. Montero understands, and provides you an interior as versatile as it is roomy, with plenty of seating and storage options for work, fun or daily life.



Seat Arrangements



With the 3rd row stowed, the 1st and 2nd rows can be laid flat, creating a comfortable sleeping area.

The 2nd row has a 60:40 split, allowing you to carry extra-long cargo while still seating four comfortably.

Fold up the 2nd row as well to make full use of Montero's massive carrying capacity.

Convenient Folding 2nd and 3rd-row Seats

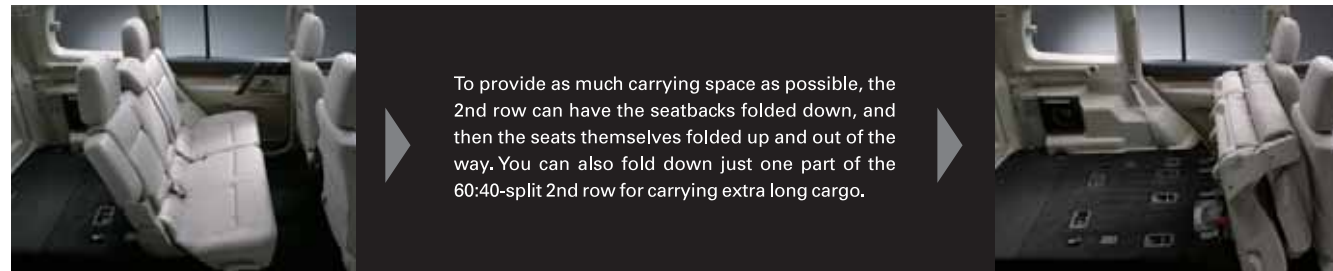

To provide as much carrying space as possible, the 2nd row can have the seatbacks folded down, and then the seats themselves folded up and out of the way. You can also fold down just one part of the 60:40-split 2nd row for carrying extra long cargo.

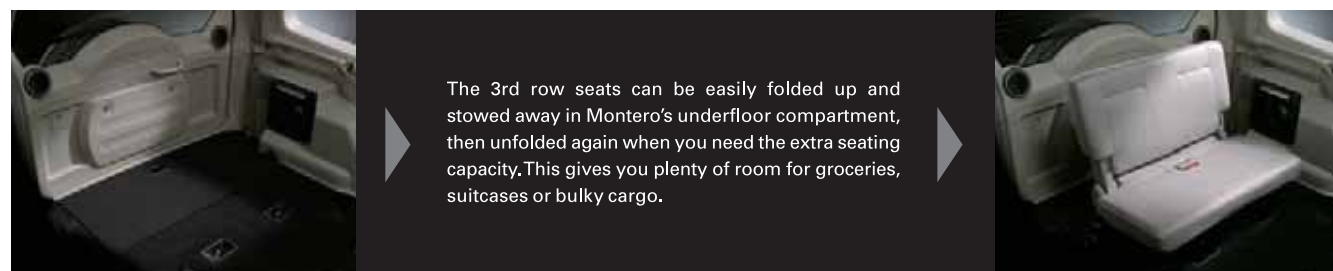

The 3rd row seats can be easily folded up and stowed away in Montero's underfloor compartment, then unfolded again when you need the extra seating capacity. This gives you plenty of room for groceries, suitcases or bulky cargo.

PREMIUM ENTERTAINMENT

Few things are as fun as listening to your favorite tunes as you head down the road. Now you can enjoy them as never before with Montero's powerful new sound system that turns the driver's seat into a front-row concert seat.



ROCKFORD
ACOUSTIC DESIGN



Rockford® Premium Sound System

This system consists of 12 speakers, including tweeters, woofers and subwoofers. Positioned throughout Montero, they are optimally balanced for automotive listening.



AM/FM radio and 6-CD player with AUX-in



Audio Controls on Steering Wheel

For convenience and safety, stereo controls are built into the steering wheel, allowing the driver to adjust the sound system with both hands on the wheel.

860W High Power Amp and 12-speaker System

The powerful amplifier and high quality speakers are capable of producing all the power and clarity of a home sound system, giving you complete music enjoyment everywhere you go. Output levels can even be automatically balanced for different music styles, and can also be centered on individual passenger positions.

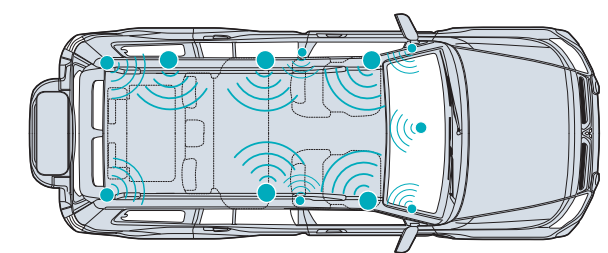

5.1-channel Theatre Surround Sound

The 5.1-channel theatre surround sound system balances front and rear speakers with the powerful subwoofer to create the feeling of being right in the centre of the action. The sound balance can be adjusted to centre on the 1st row or 2nd row, or to provide an even balance for the whole interior.

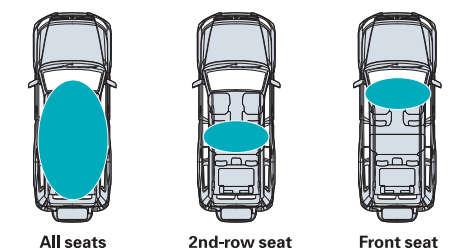

All seats

2nd-row seat

Front seat



ENGINE PERFORMANCE

The control that put Montero in the Dakar Rally record books didn't come by skimping on engine power. The rugged outdoors are unforgiving on those who show up unprepared, which is why Montero comes with the new Common Rail Direct Injection engine to provide ample power for all conditions.



Performance Curves

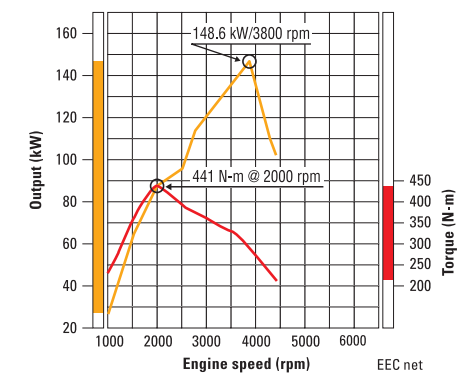

The 3.2-litre diesel engine provides superior torque, especially at low and mid rev ranges. The new Common Rail injection system electronically controls fuel intake to deliver precisely the right amount to each cylinder, while the direct injection system enables far more efficient combustion for better fuel efficiency and reduced emissions.

Common Rail Fuel System



The critical factor in precision diesel engines is pressure. By using a Common Rail to supply fuel injector lines, a single pump can provide constant high fuel pressure. In addition, the ECU electronically controls fuel flow to allow three injections with every cycle, maximizing power output while minimizing waste and emissions.

Cyclone-type Pre-air Cleaner

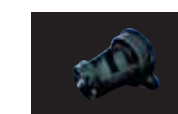

To perform at its best, an engine needs a continuous flow of clean air. The pre-air cleaner, increases air intake while filtering out dust and moisture. With the engine breathing easy, Montero is ready to take on any road.



AWC

All Wheel Control

Control. Without it, all the speed and power in the world won't get you across the finish line. More than a technology, All Wheel Control is our guiding philosophy. Mitsubishi and Montero have come to dominate racing events like the Dakar Rally by making driver control top priority through design, construction, and testing. Our success has come as a result of continually developing new ideas, such as ASTC (Active Stability & Traction Control System), monocoque body with built-in ladder frame, SS4 II, and our advanced independent suspension system. The lessons learned on the world's toughest courses have gone into the creation of every Mitsubishi vehicle, providing drivers everywhere with unmatched control around the world.



- 4-wheel Traction Control**
- Monocoque Body with Built-in Ladder Frame
 - Front Midship Layout
 - Independent Suspension



- 4-wheel Power Control**
- Super Select 4WD II (SS4 II)



- 4-wheel Slip Control**
- Multi-mode ABS + EBD
 - ASTC
 - Independent Suspension

AWC (ALL WHEEL CONTROL)



Aluminum hood panel

Monocoque Body with Built-in Ladder Frame

They say that superior off-road handling capability could only come at the expense of on-road smoothness. They have obviously never driven Montero. By incorporating a lightweight and highly rigid monocoque body with a built-in ladder frame that provides added resistance to torsion and flexing and fixing them atop a dynamic

independent suspension, Montero achieves an unprecedented combination of all-terrain control and luxury-sedan comfort. For added durability, Montero now makes more extensive use of galvanized steel body panels, while the new aluminum hood panel reduces weight for better handling.

Front Midship Layout

The engine on Montero has been shifted back closer to the centre of the vehicle. This places more weight between the axles to greatly improve handling and control. In addition, the new engine position allows a better approach angle and provides added crumple zone protection in the event of an accident.

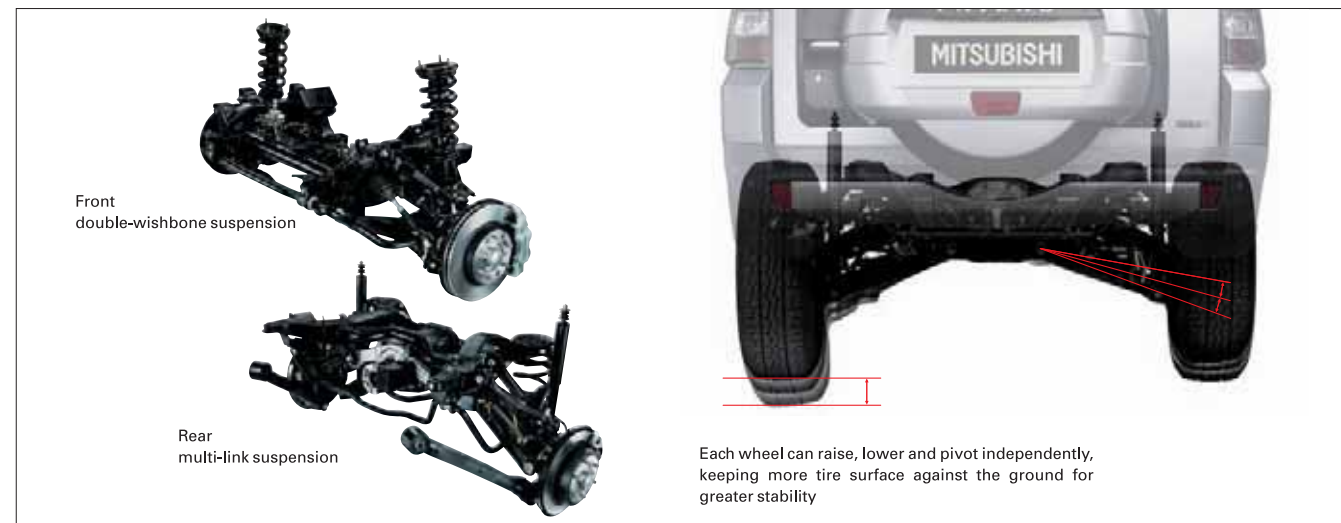

Front double-wishbone suspension

Rear multi-link suspension

Each wheel can raise, lower and pivot independently, keeping more tire surface against the ground for greater stability

Independent Suspension

Montero's rally-proven all-wheel independent suspension gives drivers confident, predictable handling in even the most unpredictable road conditions. The front double-wishbone and rear multi-link suspension systems use coil springs to provide quick and natural response, especially when cornering.

Suspension Travel

The independent suspension, coil springs and monocoque body all work together to provide a greater degree of suspension travel than other SUVs are capable of. The result is impressive road-handling and greater stability even over the roughest off-road conditions.

ASTC (Active Stability & Traction Control System)

ASTC utilises a network of control units and intelligent sensors to monitor vehicle status as well as the driver's steering. As road and vehicle conditions change, ASTC manages the forces on all wheels by precisely controlling engine torque and braking force going to each one, providing improved vehicle control, trace ability and traction in all driving conditions. ASTC lets driving enthusiasts enjoy the full potential of Montero in complete confidence.

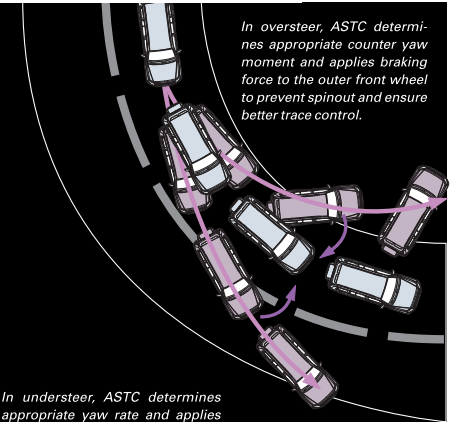

In oversteer, ASTC determines appropriate counter yaw moment and applies braking force to the outer front wheel to prevent spinout and ensure better trace control.

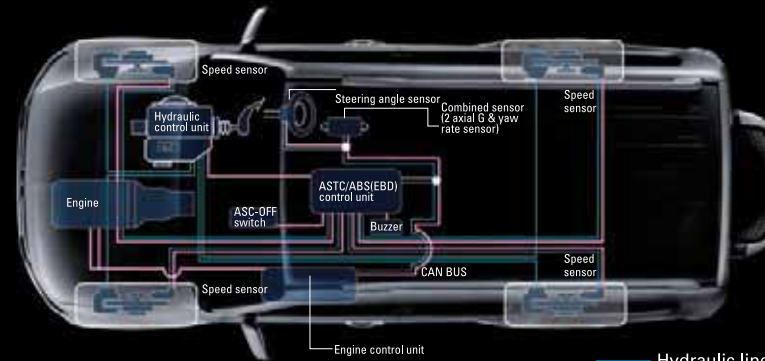

Hydraulic lines
Electric lines

In understeer, ASTC determines appropriate yaw rate and applies braking force to the inner rear wheel to prevent drift-out and ensure better trace control.

ASTC calculates real-time vehicle status via sensor data. Whenever the potential for oversteer or understeer in corners is detected, ASTC determines the correct yaw for Montero and applies braking force to the appropriate wheels. This enables drivers to maintain control even in slippery road conditions.



Rally-proven Technologies

Mitsubishi's advanced control technologies were first conceived and developed to meet the challenges of the world's most gruelling rally courses. Proven under real-world conditions more demanding than any test track, they are now ready to go into Mitsubishi vehicles like Montero.

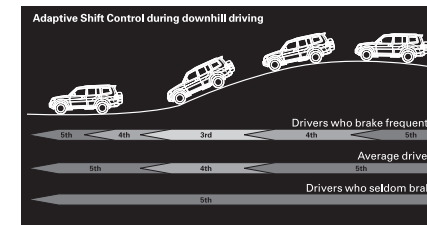

Super Select 4WD II (SS4 II)

Montero's advanced SS4 II lets you shift between 2H, 4H and 4HLc modes at speeds of up to 100km/h, providing on-demand control for high-way performance or off-road traction whenever you need it.

Exclusive INVECS-II A/T

INVECS-II studies driving habits and complements them. Optimum Shift Control analyzes conditions and driving style, comparing them to its database of shift patterns to balance power, control and efficiency. Adaptive Shift Control studies acceleration and brake timing, then learns to anticipate driver actions.

Sports Mode for A/T

Standard on all A/T models, Sports Mode delivers the excitement of a manual shift while still providing the convenience of an automatic. Changing gears for enhanced response and performance with just a touch of the shifter, Sports Mode reminds you of what driving was like back when you first learned how.



2H

(2WD high range)
For cruising down the highway or just making a quick trip across town, 2H mode shifts you into rear-wheel drive for a smooth, quiet and fuel-efficient performance.



4H

(4WD high range)
When the weather gets bad and the roads start turning rough, 4H mode provides added traction. The dynamic front/rear torque split adjusts between 33:67 and 50:50 to give you greater control for high speed driving.



4HLc

(4WD high range with locked centre differential)
Keeping you on track even in rugged or slippery conditions, the 4HLc mode distributes power to all four wheels equally for off-road excitement with a steady sense of control.



4LLc

(4WD low range with locked centre differential)
Switch to 4LLc mode when you need all the tractor-like crawling power Montero is capable of. Maximized low-end torque pulls you through even the roughest terrain, stickiest mud and deepest snow.

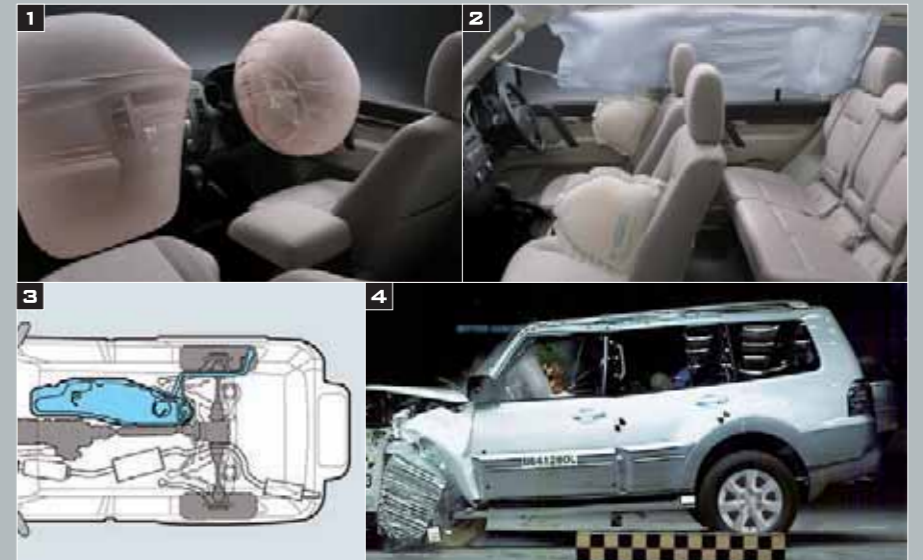

1 Dual-stage SRS Airbag System

In the event of a forward collision, the driver and front passenger are both protected by front SRS airbags. To further increase safety, the onboard computer measures the force of impact and adjusts airbag deployment speed to best reduce the chance of injury to occupants.

2 Side and Curtain SRS Airbags

In a side collision, the driver and front passenger are protected by side mounted airbags set to deploy at just the right position regardless of seat position. Furthermore, curtain airbags mounted in the ceiling lining deploy to protect front and 2nd-row occupants.

3 Safety-design Fuel Tank

Positioned ahead of the rear axle to help prevent leakage in a collision, Montero's fuel tank is also guarded by a tough resin underprotector.

4 RISE Body

Using front and rear crumple zones to absorb and diffuse collision damage before it can reach the cabin interior, Montero's RISE (Reinforced Impact Safety Evolution) body design is built to keep occupants safe, regardless of which direction trouble comes from. The rigid monocoque body provides further protection by encasing occupants within a steel framework that resists damage.

SAFETY AND RELIABILITY

Accidents happen. Mitsubishi knows that sometimes the road throws an unexpected surprise in your path, so Montero is outfitted with an array of advanced active and passive safety technologies. Enjoy your drive with the peace of mind of knowing that you and your passengers are safe and secure.

Monocoque Body with Built-in Ladder Frame

The strength of Montero's ladder frame has been nearly tripled over previous designs, providing even better resistance to torsional and flexural stresses without any further increase in weight. This rigidity translates to better handling over difficult road conditions and lower chance of control loss.

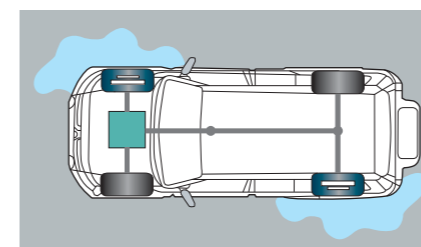
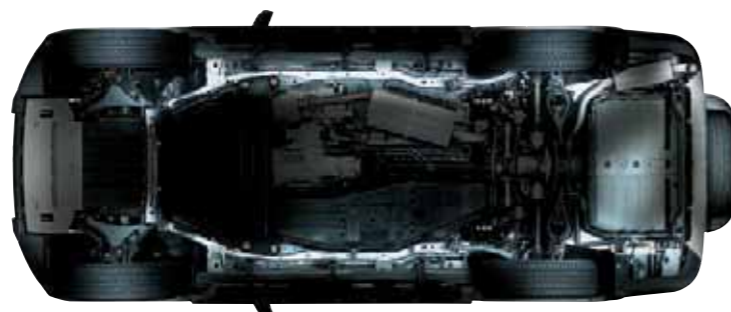

ASTC (Active Stability & Traction Control System)

ASTC analyzes the forces acting on Montero to anticipate control loss and take preventive measures. Additional braking is delivered to the wheels that need it, enabling you to hold your line precisely through each turn.

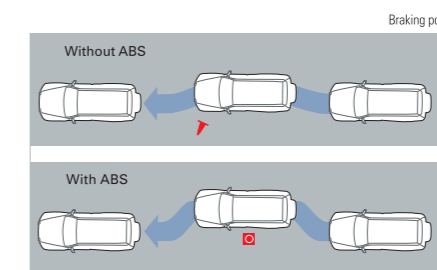

Multi-mode ABS (Anti-lock Braking System)

When the road throws you an unexpected curve, ABS ensures that you'll be ready. The 4-sensor, 4-channel system is matched to each SS4 II mode to ensure skid-free braking regardless of surface conditions.

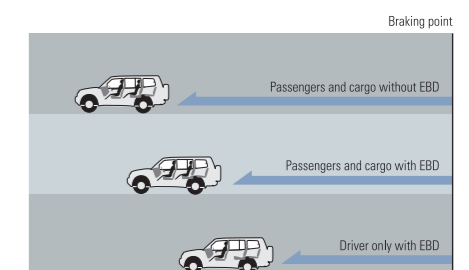

EBD (Electronic Brake-force Distribution)

EBD modulates each braking channel independently, providing additional force to the rear wheels when the vehicle is carrying passengers or cargo. This ensures you are able to come to a stop quickly and safely, regardless of load or road conditions.

STANDARD EQUIPMENT

ITEM	
Exterior	Chrome front grill
	Clear lens HID headlights with auto-levelling
	Retractable headlamp washers
	Front & rear fog lamps
	Colour-keyed bumpers
	Front and rear mudguards
	Silver painted front skid plate
	High-mount stop lamp
	Rear window defogger with timer
	Butterfly type rear quarter windows
	Front variable intermittent washer and wiper
	Rear intermittent wiper and washer
	Colour-keyed door handles
	Colour-keyed electronically controlled door mirrors with turn signal, approach lamp and folding function
	Spare tyre cover
Glass Antenna	
Interior	Silver-accent power window panels
	Chrome-accent inner door handles
	Illuminated cigarette lighter
	Anti-skid pedals
	Sunglass holder
	Adjustable centre armrest with console box
	Front cup holders
	Rear centre armrest with cup holders
	Accessory socket inside floor console box
	Can type ashtray
	LED foot light for Driver and passenger
	Driver's and front passenger's seatback pockets
	Sunvisor with ticket holder (driver only), extendable, vanity mirror with lid and light
	Retractable assist grips x 6
	Coat hanger x 2
	Electronic Chromic rearview mirror
	Cargo room under floor compartment
	Cargo room hook x 4
Illuminated Glove Box	
Cockpit	Leather wrapped steering with audio control and cruise control
	Wood finish/carbon finish interior panels
	Illuminated key cylinder with delay timer
	Rheostat
	RV meter (dual-tone display showing time, date, compass, barometer, altimeter, A/C settings, internal & external temperature)

Seats	Front	5-way power seats for driver & 2-way power seats for passengers with heater function	
		Leather seats	
		Fully flat function	
	2nd-row	Height and tilt adjustable headrests	
		60:40 split seats	
		Leather seats	
		Fully flat function	
		Recline adjusters	
	3rd-row	Tumble-type fold-up function	
Height adjustable headrests x 3			
Leather seats			
Front-facing removable with stowage function			
Safety	Multi-mode ABS,EBD and hydraulic brake booster		
	ASTC (Active stability and traction control system)		
	Collapsible steering column		
	RISE body		
	Immobilizer, Theft alarm and sensor		
	Keyless entry system		
	Child-protection rear door locks		
	Airbags	Front dual stage airbags (both sides) with cut off switch (passenger side)	
		Side airbags	
		Curtain airbag	
	Seatbelts	Front	3-point ELR with pre-tensioner
			Height-adjustable seatbelt anchors
		2nd-row	3-point ELR seatbelts x 3
			Tether anchors for ISO FIX seat
		3rd-row	3-point ELR seatbelts x 2
Functional	Super Select 4WD (SS4-II)		
	Power steering with tilt-adjustable steering column		
	Central door locking with Keyless entry system (includes tailgate lock)		
	Anti-trapping power windows		
	Cargo room accessory socket		
	Rear heater		
	Fully automatic air conditioner		
	Parking sensors		
	Tonneau Cover		
	Approach lamps		
	Rockford Audio system (860W high power Amp and 12 Speaker system with 5.1 channel theatre surround		
	Interior lighting	Door courtesy lamps	
		LED Foot lamps	
		Cargo room lamp	

AMENITIES AND EQUIPMENT FOR DRIVING COMFORT



Chrome-plated front grill



Discharge headlamps



Headlamp washers



Cruise control



Driver's and front passenger's dual-stage SRS airbags



Side and curtain SRS airbags



Front fog lamps



Colour keyed power door mirrors with folding function



Colour keyed power door mirrors with defoggers, approach lamps and turn lamps



Front seatback pockets (both sides)



Chrome-plated inner door handles



Front door pockets



Power windows with key-off timer (auto down for driver's window)



Silver-painted front skid plate



Side steps



Power seat with lumbar support (driver only)



Seat heaters



Laminated green windshield glass with sunshade



Colour keyed outer door handles and side garnishes



Tailgate garnish and rear fog lamp



Rear intermittent wiper and washer



Sunvisors with illuminated vanity mirrors with lids



Electronic chromic rearview mirror



Tonneau cover
Provides a private cargo space

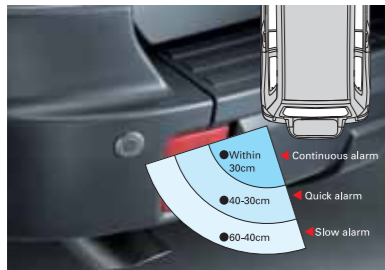

Rear corner sensor
Detects nearby obstacles



265/65R17 tyres with 17" x 7.5JJ
7-spoke light alloy wheels



4-spoke leather-wrapped steering wheel with audio controls and cruise control



Retractable assist grips



2nd-row 60:40 split seatback with 3 height-adjustable headrests

AMENITIES AND EQUIPMENT FOR DRIVING COMFORT



3rd-row front-facing removable seat with stowage function



Accessory socket on instrument panel



High contrast back-lit meters with rheostat



2nd-row seat centre armrest with cup holders



Lockable glove box



Cargo room accessory socket



Fully automatic air conditioner



Manually-controlled rear air conditioner



Keyless entry system



Aluminum pedals



Adjustable centre armrest console box with upper and lower compartments



Accessory socket inside floor console box



AM/FM radio and 6-CD player with Rockford® 12-speaker system with AUX-in



LED front foot lamps (both sides)



LED rear foot lamp on floor console

EXTERIOR & INTERIOR COLOR COMBINATIONS



Deep Blue Mica



Sophia White



Black Mica



Cool Silver Metallic



Beige Leather



Black Leather

DIMENSIONAL VIEWS

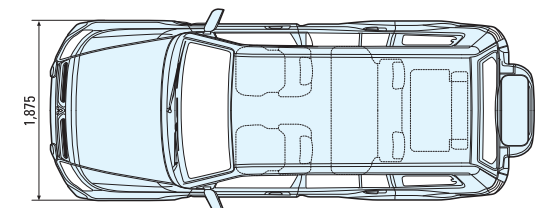
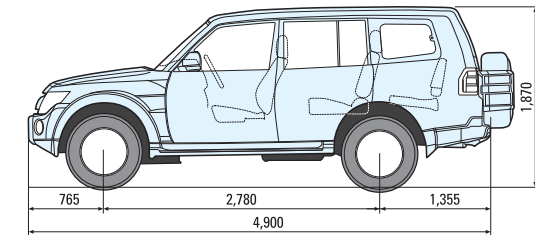
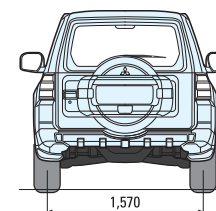
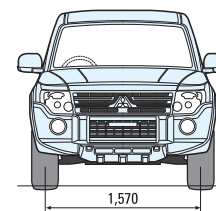

SPECIFICATIONS

ITEM	MODEL	MONTERO	
DIMENSIONS & WEIGHTS	Overall length	mm	4900
	Overall width	mm	1875
	Overall height	mm	1870
	Wheel base	mm	2780
	Ground clearance	mm	235
	Kerb weight	Kg	2310
	Gross vehicle weight	Kg	3030
	Seating capacity		7
PERFORMANCE	Max. speed	Km/hr	174
	Max. climbing ability	4WD/2WD	35.0°/15.0°
	Approach angle		36.6°
	Ramp break-over angle		22.5°
	Departure angle		25.0°
	Min. turning radius	m	5.7
ENGINE	Type	DOHC 16-valve, In-line 4-cylinder, Diesel, Intercooled turbocharger	
	Displacement	cc	3200
	Max.output	kW/rpm	148.6kW@3800rpm
	Max.torque	N-m/rpm	441Nm@2000rpm
FUEL SYSTEM	Fuel supply equipment	Common Rail Direct injection	
	Fuel tank capacity	lit.	88
DRIVE SYSTEM	Type	Super Select 4WD (SS4-II)	
TRANSMISSION	Type	INVECS II 5-Speed Automatic with Sports Mode	
SUSPENSIONS	Front	Independent, Double wishbone Coil Springs with stabiliser bar	
	Rear	Multi link coil springs with stabiliser bar	
BRAKES	Front	Ventilated Disc	
	Rear	Ventilated Disc	
		Multi mode ABS, EBD and hydraulic brake booster with brake assist	
TYRES & WHEELS	Front and rear	265/65R17 Tubeless 17"x7.5" JJ Alloy wheels	

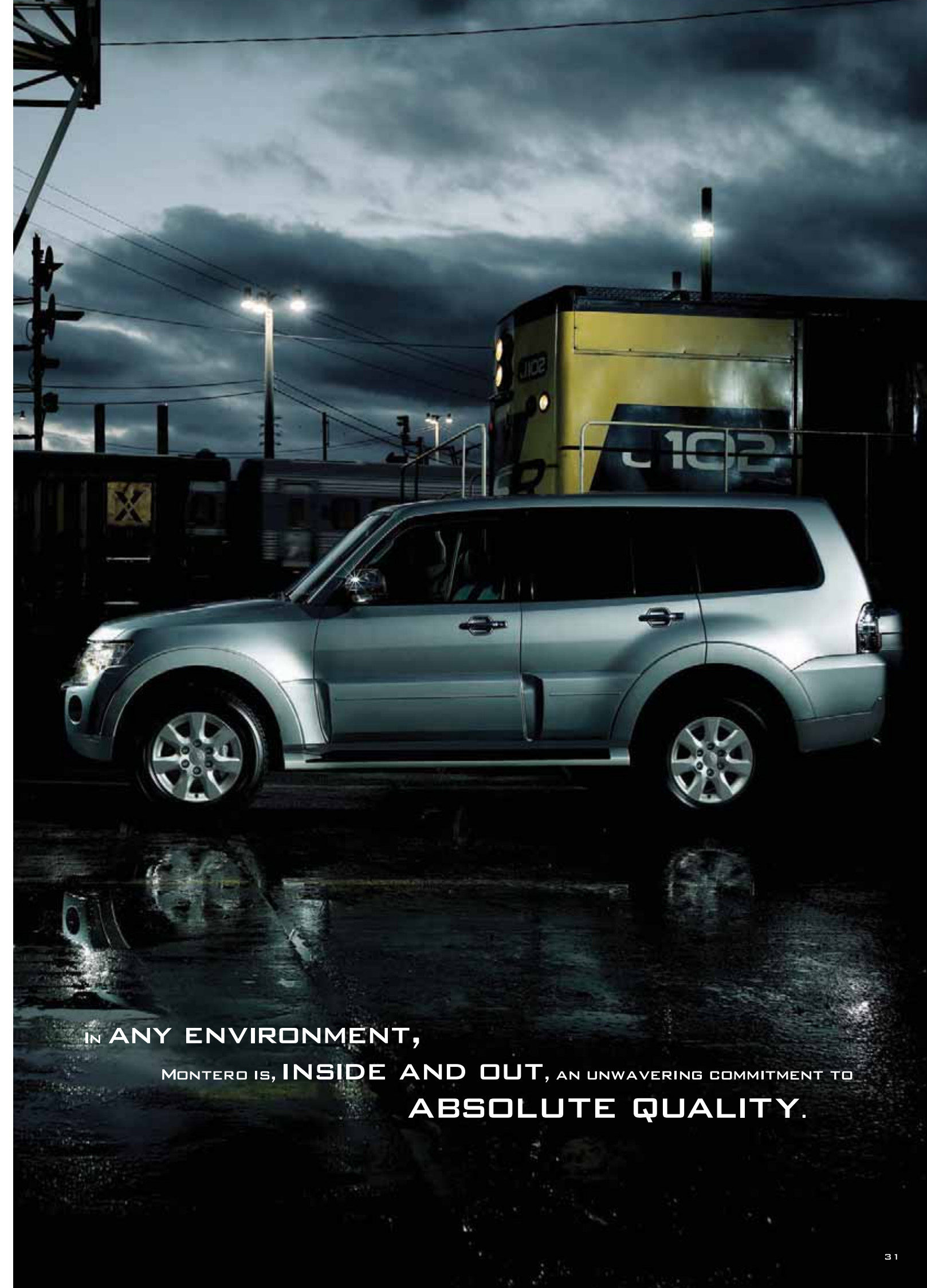

IN ANY ENVIRONMENT,

MONTERO IS, INSIDE AND OUT, AN UNWAVERING COMMITMENT TO

ABSOLUTE QUALITY.

DRIVE HOME

A WINNING HABIT.

WITH CONSECUTIVE DAKAR VICTORIES FROM 2001 TO 2007, MITSUBISHI IS INDEED TODAY THE UNDISPUTED LEADER IN PERFORMANCE VEHICLES. EVERY MACHINE IS BUILT TO HANDLE THE EXTREME DEMANDS OF RALLY SPORT.





WHICH IS MORE FULFILLING, THE **THRILL OF RACING**
TOWARD YOUR **DESTINATION**,

OR THE **SATISFACTION** AFTERWARD OF LOOKING BACK
ON THE MILES YOU'VE CROSSED IN **GETTING THERE?**

THE ANSWER IS UNIQUE TO EACH DRIVER.



Hindustan Motors Ltd., Chennai Car Plant, Adhigathur, Kadambathur
Tiruvallur District, Tamil Nadu - 631 203. Tel: 044 2764 1400.
Fax: 044 2764 2029 www.mitsubishi-motors.co.in

www.facebook.com/MitsubishiMotorsIndia www.twitter.com/MitsubishiIndia

Accessories shown here may not be part of standard equipment. Dimensions and specifications are subject to change without prior notice.



Dealer Stamp