



THE NEW
VOLVO XC60



INNOVATION FOR PEOPLE

Made by Sweden.

At Volvo Cars, we continuously innovate in order to make your life better. Every car, every technology and every design is the result of a clear vision – to put people at the heart of everything we do. It's a vision that has driven us from the start, one informed by Sweden, a country which values people as individuals and where conventions are challenged. It's a culture with a rich design heritage and a unique way of looking at the world.

This vision has inspired us to create the three-point safety belt and side-impact airbags amongst others – inventions that have saved lives and changed automotive history. And with our new generation of cars we continue with this tradition. Scandinavian design combines with modern Swedish luxury to enrich your experience. Intuitive Sensus technology makes life less complicated and keeps you connected with the world. The Drive-E powertrains balance responsive power with class-leading efficiency. Our IntelliSafe innovations make your journey more comfortable and enjoyable while helping to prevent accidents.

We understand what's important to people. It forms the basis of all innovations. Innovations that improve lives.

At Volvo Cars we design our cars around you.

Contents

Exterior design.....	4	IntelliSafe.....	22	Accessories.....	38
Dynamic handling.....	8	Drive-E.....	30	Facts and figures.....	44
Interior design.....	10	Chassis.....	32		
Versatility.....	14	Your Choice			
Sensus.....	16	Inscription.....	34		





In Sweden, we build SUVs differently. We start with the concept of designing around you – a car that must look beautiful, engage the driver and make itself useful. We create an exterior that mixes muscular dynamism with clean, elegant Scandinavian design. We find the perfect balance between comfort and control and use it to build the chassis. We craft an interior from the finest Swedish materials, making sure it's full of natural light, and packed with clever touches that make every day easier.

The result is the new Volvo XC60. A car that's as good to drive as it is to look at. Filled with our latest technology to deliver an experience that rewards and fulfills.

This is the Swedish SUV. Evolved.

"One glance tells you this is a car that's ready for whatever activity or adventure awaits."

THE SCANDINAVIAN ATHLETE

Refined strength, designed in Sweden.

With its dynamic, perfectly crafted, elegant exterior, the new XC60 is an SUV that makes a strong visual statement.

Beautifully crafted details let you know that this is a Volvo. With its sharp creases and curves, the sculpted bonnet helps create an impression of strength and refinement. Large wheels and pronounced wheel arches express the car's athleticism and capability. One glance tells you that is a car which is ready for any activity or adventure awaits.

Full-LED headlights with distinctive T-shaped daytime running lights create an unmistakable impression, day or night, while rear lights that flow into the tailgate are a Volvo design cue that emphasise the car's strength.

From every angle the new XC60 is the SUV with a unique Scandinavian attitude.

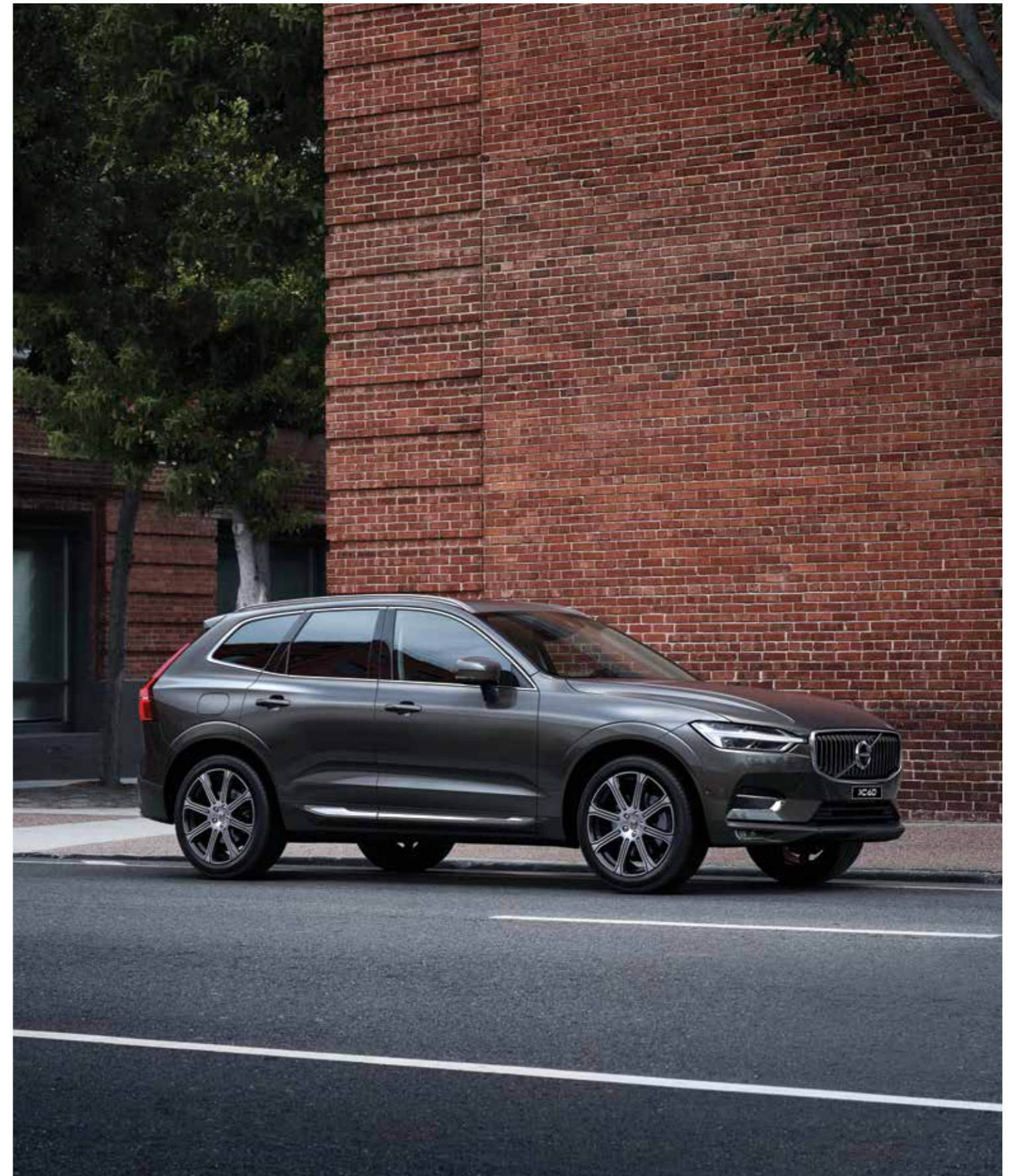

The new XC60 possesses all the qualities of good Scandinavian design – understated yet confident, uncluttered and beautiful. It is an SUV that projects poise and power. In profile, the bonnet, rising side window line, and sharply angled tailgate highlight its dynamic nature.

Up close, the sharp creases and sculpted side panels emphasize its muscular, contemporary character. Everywhere you look there is something to delight. The new XC60 is a car that you will always be proud to own. Which you will never tire of looking at.



"That's why we crafted the XC60 to be a car that you feel inspired and confident when driving. One where you will always feel in control."



PLEASURE FOR YOUR SENSES

Crafted for an enjoyable drive.

The new XC60 is built for enjoyment, because we think you should enjoy every drive in your car, no matter how short or long the journey. That's why we crafted the new XC60 to be a car that you feel inspired and confident of when driving. One where you always feel in control, and where technology is there to support you and make every interaction second nature.

With its strong, lightweight construction and sophisticated suspension components, the chassis of the new XC60 finds just the right balance between comfort and control. It offers great driver feedback and leaves you feeling fresh, even after a long journey. Experience the rewards offered by the dynamic handling in a cabin that provides outstanding comfort and a calm, restful environment. With seats designed to perfectly complement the human form, quiet powertrains, and first-class sound systems that let you enjoy your favourite music as the artist intended, the interior of the new XC60 is a haven. This is the Volvo approach to driving enjoyment.



THE COMMAND CENTRE

Take your place behind the wheel.

When you sit in the driver's seat of the new XC60 you're in control.

In control of everything the car can do for you and in control of your journey. From the driving position to the way you interact with the navigation system.

The experience starts with the driving environment. The dashboard and centre console wrap around, creating the feel of a cockpit and putting you in command. Beautifully designed and finished controls make every interaction with the new XC60 a pleasure.

We put as much thought into materials as we do into design. The tailored dashboard with contrasting stitching and driftwood inlays allow the materials to speak for themselves. You're surrounded by the precision of skilled craftsmanship, where everything works with accuracy and precision. In the new XC60 it's effortless to be in command.

"Light floods in through the panoramic roof to make the cabin bright and airy."

The panoramic roof extends the full length of the cabin, flooding the interior with natural light – so everyone gets the benefit.

YOUR SANCTUARY.

When designing the interior of our cars we apply the same principles you would when designing a living room. High-quality materials, intelligent use of space, and attention to detail work together to create a warm and inviting environment. And it's for everyone. Everyone who travels in the new XC60 gets the same standards of comfort, space, light and design. Everyone will enjoy the journey, no matter their seat. Welcome to a sanctuary that calms and soothes.

Exceptional seating is at the heart of the experience. We build all of our seats to give the same high standards of comfort and support, with plenty of adjustment so everyone can find a position that suits them.

The design of the interior is as important as the way it's built. Light floods in through the panoramic roof to make the cabin bright and airy. Reducing the number of buttons and switches creates a distinctly Swedish feel of uncluttered calm. And the clever use of space, such as the storage compartments under the rear seats, is typical Scandinavian ingenuity. They're just the right size to store electronic devices, such as a tablet, out of sight.

Unlock the car and the door handles light up to make getting into the new XC60 quick and easy. At night the cabin glows with a warm interior lighting, welcoming you into the car. The optional lighting package includes ground lighting in all of the doors to illuminate the area below an open door, so you can avoid stepping into puddles, as well as additional interior lighting such as a worklight in the tailgate. CleanZone technology means the air you breathe inside the car is clean and fresh, regardless of the air quality outside the vehicle. It filters dust, pollen, particulates and odours while monitoring the air quality and closing the intakes if pollutant levels rise too high. It happens automatically – all you need to do is set the temperature you want and the new XC60 does the rest.



Rich materials and intricate detailing, like the Driftwood trim, and yellow speaker cones, provide contrast and visual interest.



The combination of clear, easy-to-read instruments and the distinctive lines of the dashboard look great and work beautifully. They exemplify the meeting of form and function.



The way we've reduced the number of buttons has created a clean, uncluttered cabin reminiscent of the traditional, functional design of Swedish homes.

"The XC60 is versatile, a place which complements and copes with your active life, with extra usefulness built in."

VERSATILITY'S NEW LOOK

Making every day easier.

A car has to be more than a great design and a rewarding driving experience. The new XC60 is versatile. It complements and copes with your active life, with extra usefulness built in. Even getting into the new XC60 is easy – you can open the powered tailgate by waving your foot under the rear bumper. Inside you'll find a large, evenly shaped load compartment that makes it easy to accommodate irregular sized objects. Fold the seats at the push of a button and you get a fully flat load floor – and you can do this from the rear of the car.

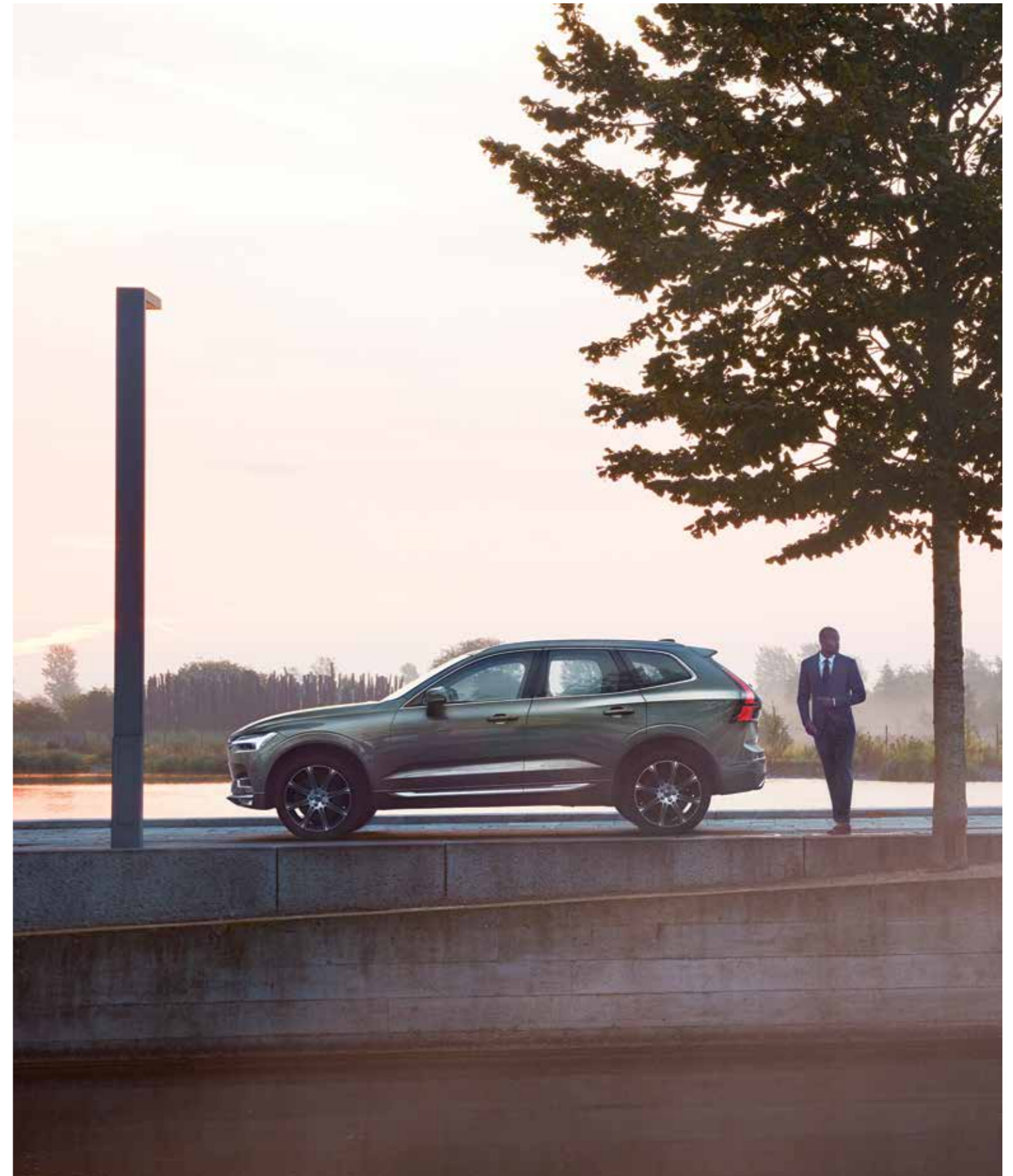

"Sensus connects you with your Volvo and the rest of the world."



SENSUS

*Informed, in control and
always up to date.*

What is Sensus? Sensus is our approach to technology, one that has a guiding principle – to make your life easier and more enjoyable. Be it comfort, entertainment, or navigation requirements. Sensus connects you with your Volvo and the rest of the world. It keeps you informed, entertained and in control of your journey. Intuitive, easy-to-use controls are a prime feature of Sensus and you will find them on the large, 22.86 cm (9 inch) centre display with touchscreen. Replacing physical buttons with virtual equivalents on the screen allows them to be larger and easier to use, while making the cabins feel less cluttered. Bold and clear graphics make it easy to absorb information at a glance. Our philosophy has always been that you should be able to operate your Volvo and keep your eyes on the road. The optional head-up display means you can do just that while staying connected and informed. Our audio systems get you closer to the performance and offer considerable flexibility when it comes to choosing your desired music source. Tailoring its sound to your individual preferences. The Sensus experience enriches every moment that you spend in your Volvo.

CONNECTING YOU WITH A WORLD OF ENTERTAINMENT.

Get closer to the music you love, no matter which seat you're in. With Sensus Connect all of your music is available all of the time, whether it's direct from your favoured media source or streaming from the internet using your phone. It all begins with the 22.86 cm (9 inch) centre display, the control centre for Sensus. The surface responds to the lightest of touches you only need to brush your fingers over the glass to operate the controls. It even works with gloved hands. Connecting your devices is quick and easy. Simply plug your

iPhone® into the car using the USB connection and you can turn the centre display into an extension of your iPhone® using Apple CarPlay™. When it's connected to Apple CarPlay™ your phone will be charging, too. And Android smartphone users can connect with Android Auto™ to access your device's music, make calls and send messages. Our High Performance audio system is tuned to make the most of your music, while the Bowers & Wilkins system takes the listening experience to another level.

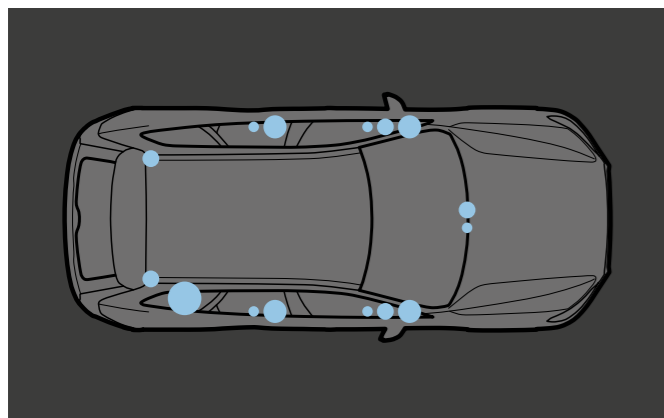

Our **Bowers & Wilkins** audio systems gives every occupant a superb listening experience, no matter which seat they are sitting in. Developed with speaker makers Bowers & Wilkins, this innovative technology brings exceptional clarity and realism to your favourite music. The unique air-ventilated subwoofer delivers richer, deeper bass by drawing air in from outside the car so it can pulse more air through the speaker. There are 15 speakers, allowing



everyone in the car to get the best possible sound, all the time. And you get closer to the performance by using one of the system's three room modes to bring the music to life. Concert mode recreates the unique acoustic experience of the Concert Hall in Gothenburg, Volvo Cars' hometown, while Stage and Studio modes put you at the heart of the music, allowing you to hear it as the musicians intended.

"The Bowers & Wilkins audio takes the listening experience to another level."



22.86 cm (9 inch) centre display. The focal point of the elegant cabin is the 22.86 cm (9 inch) centre display with touchscreen, which uses a portrait format to give you a large viewable area that means less scrolling. This format is perfectly suited to displaying maps,

and mirrors the look of modern smartphones in its layout, so it feels instantly familiar and intuitive. It features a glossy black finish that, thanks to a special coating, minimises reflection – so it not only looks beautiful but works beautifully. This is how technology should be.

GET TO YOUR DESTINATION EVERY TIME, WITH EASE.

Let Sensus Navigation be your guide, helping you find your destination and keeping you informed. Our sophisticated navigation uses intuitive technology so that wherever you go, you'll get there quickly and easily.

Everything you need to know is shown on the 30.48 cm (12 inch) driver display right in front of you. The high-resolution image self-adjusts so it's never too bright; automatically resizing the instruments to accommodate navigation information. The head-up display shows all the vital information on the lower part of the windscreen, projected to look like it is hovering in front of the car. It means you stay informed without ever having to take your eyes off the road.

Getting to your destination is made even easier with the portrait format, 22.86 cm (9 inch) centre display with touchscreen. It makes viewing and following routes on maps particularly easy as the vertical screen replicates the format of a road atlas, displaying more of the road that you are travelling on.

With Sensus taking care of the way ahead, you can enjoy the journey.

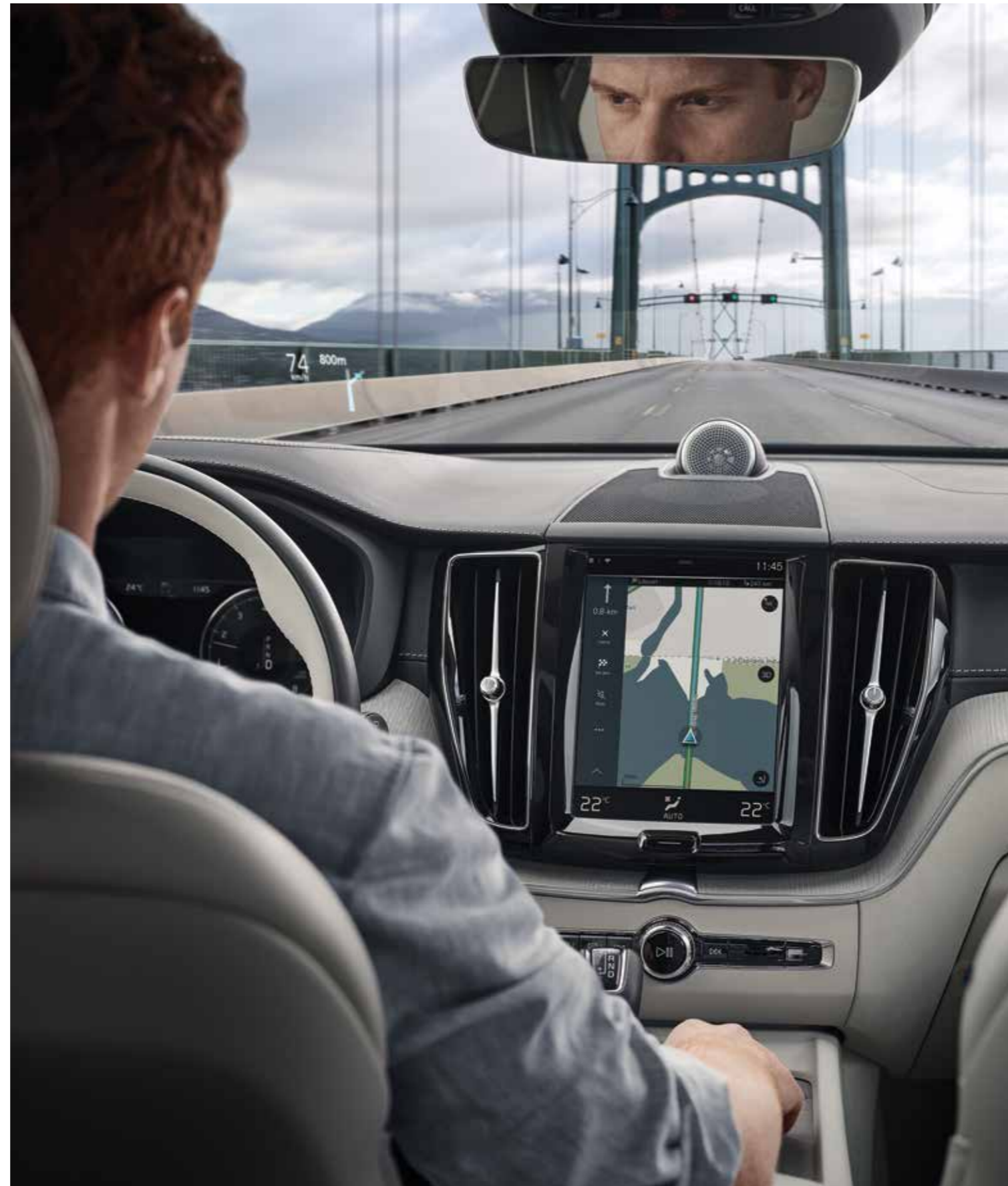

Centre display. The portrait format centre display with touch screen makes reading maps and following navigation prompts beautifully straightforward. Maps appear as they would in an atlas and they scroll less, so you can see where you're going and what's coming next. Its clarity, size and orientation make it the ideal companion for every journey.



Voice control. Controlling Sensus is as easy as telling it what to do. Talk to your Volvo, using natural phrases such as "go to Industrigatan, Göteborg" "call Nikhil Khanna", and voice control will carry out your instructions for using the navigation and infotainment, calling from your smart phone, or operating the climate control.

With Oncoming Lane Mitigation your Volvo helps reduce the risk of colliding with an oncoming vehicle. Active at speeds from 60km/h, it automatically steers you back into your lane if it detects that you have crossed the lane markings and into the path of an oncoming vehicle. You can override the automatic steering at any time by taking control of the steering wheel and it can be turned off altogether.

INTELLISAFE

Always looking out for you.

IntelliSafe is our name for the intuitive, intelligent Volvo Cars technologies that support your driving, help to prevent accidents and protect you in a collision. These innovations play a key role in helping us realise our bold vision that, by 2020, no one will be killed or seriously injured in a new Volvo car. City Safety is at the heart of IntelliSafe. Fitted as standard, it's like a co-pilot that's looking out for you, detecting danger ahead then warning you and intervening if necessary. City Safety identifies other vehicles, pedestrians, cyclists and large animals ahead of you, even at night. It warns you of any hazards and, if you don't react, it will brake automatically to help avoid or mitigate a collision and can help you steer around obstacles in the road and avoid oncoming vehicles. Steering Support predicts if you are about to hit something. If you start to steer, but not enough, it will try to increase the steering, making rapid manoeuvres safer and more effective.

IntelliSafe supports you on every journey. Oncoming Lane Mitigation can help avoid collisions with oncoming vehicles by automatically steering the car out of the way. Run-off road Mitigation steers and, if necessary, brakes to help prevent you leaving the road accidentally. Driver Alert Control recognises if you're tired or distracted and suggests that it's time to take a break, while Road Sign Information reminds you of the speed limit. Reducing the impact of a collision is just as important as avoiding the collision. We invented the safety belt over 50 years ago and we've never stopped innovating: our latest advances include seats that help cushion your spine from vertical impact forces. With safety technology that's as advanced as this, your Volvo can help make every day safer. For you, your passengers and everybody.

*"With advanced safety technology,
your Volvo can help make every day safer."*

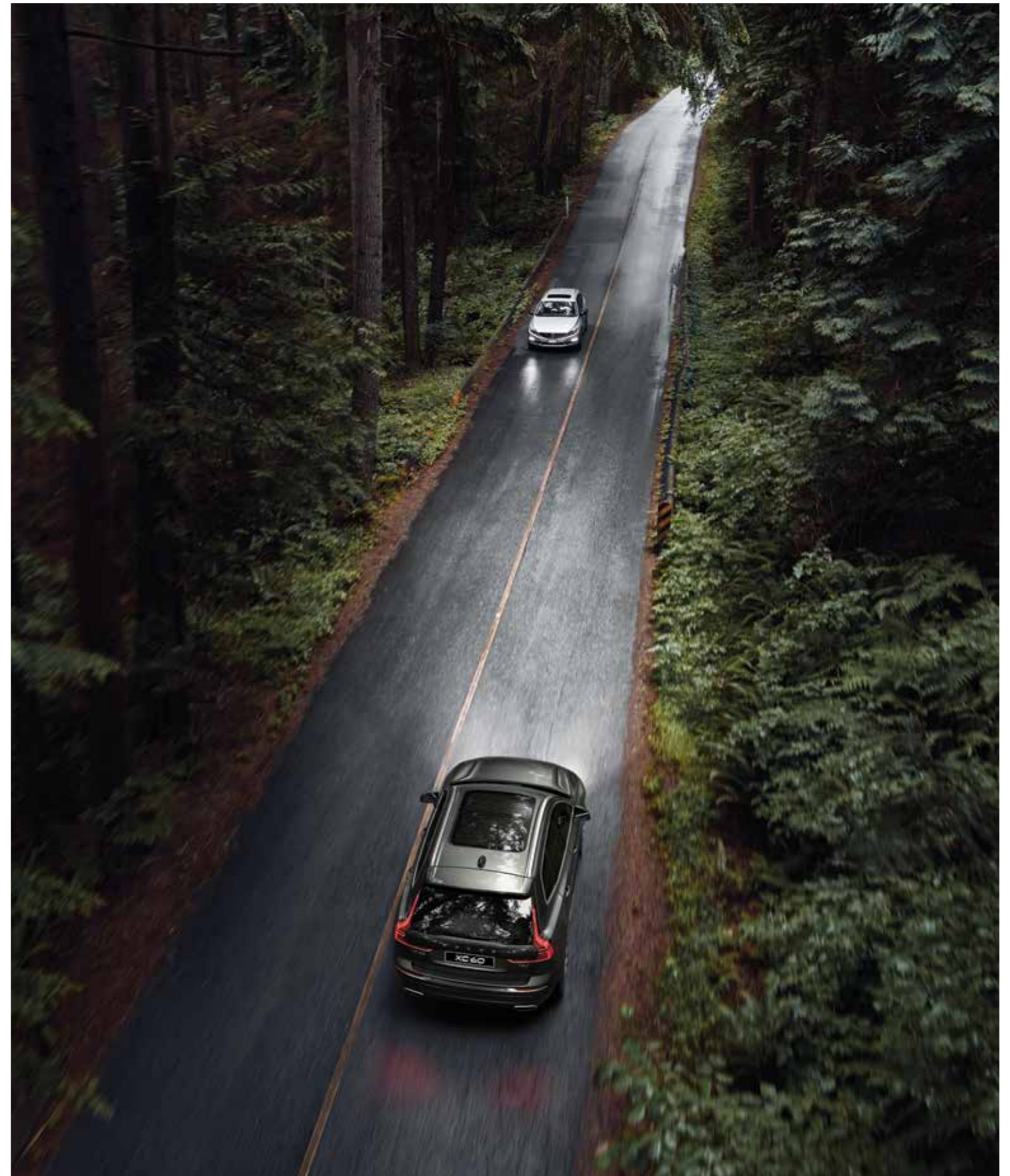

When you need to avoid an obstacle in front of you, City Safety can help make the manoeuvre safer and faster. In these situations, if you steer quickly around the object, Steering Support adds extra effort as you turn the wheel. This turns the front wheels the correct amount to help

you avoid the object while braking both inner wheels to help make the turn more effective. At the same time it coordinates the braking with the steering so they're working together.

Cross Traffic Alert technology helps you reverse out of a space knowing that there are no vehicles about to collide with you. This technology can spot vehicles approaching from either side of your Volvo at a distance of up to 30 metres, while cyclists and pedestrians can be detected at even shorter distances.





Our safety options add more cutting-edge technology to the comprehensive safety package that comes with the new XC60. IntelliSafe Surround includes Blind Spot Information with Steer Assist for increased awareness and confidence on the highway, alerting you of vehicles alongside you. If you don't react to the warnings and start to drift into the path of another vehicle, the Steer Assist function will gently guide you back into your lane. Rear Collision Warning detects if another vehicle is about to hit you from behind and flashes the hazard lights more quickly than usual. It also tenses the safety belts. Cross Traffic Alert tells you if there's a vehicle, cyclist or pedestrian in the blind sectors when you're reversing out of a parking space. IntelliSafe Assist adds Adaptive Cruise Control and Pilot Assist, which help support the driver and make driving less tiring. Adaptive Cruise Control keeps the new XC60 at a set distance from the car in front; the driver sets the gap and the new XC60 will adapt its speed to maintain that distance. Pilot Assist helps keep the car in the centre of the lane by making small adjustments to the steering. It works at speeds up to 130km/h and helps make journeys more relaxing.



PROTECTING WHAT'S MOST IMPORTANT.

Protecting you and your passengers has always been our priority at Volvo Cars. Our latest generation of cars do much more to keep you safe. From preventive technology that helps you avoid collisions to protective features that cushion the impact of any collision, we will never stop innovating in order to improve your safety. The body of the new XC60 provides you and your passengers with maximum protection in all types of accidents. The foundation for our new generation of cars is a very strong passenger compartment that uses a high percentage of ultra high-strength boron steel to create a protective cage around you and your passengers. Volvo Cars gave the world the three-point safety belt in 1959 and our latest developments continue this commitment to life-saving

inventions. Should your car leave the road, Run-off road Protection technology reduces your chances of suffering serious injury. Prepared front safety belts automatically tighten when the car senses that an impact is imminent, ensuring that you and your passenger are in the safest position if a collision occurs. If the car leaves the ground as a result of running off the road then our unique energy-absorbing seats help to protect your spine in the event of a hard landing. It's this range of safety technologies and attention to detail that makes your Volvo a safe place to be.



The sculpted front seats are more than just beautiful to look at. Their unique structure helps to absorb a vertical impact, helping to protect your spine if the car lands heavily after leaving the road. It's another example of how we make every part of a Volvo work harder for your safety.

Volvo is synonymous with road safety. We put our first safety cage into production in 1944, and created the three-point safety belt back in 1959. And we're still innovating today. Prepared front safety belts tighten automatically if the car detects that a collision is likely, to ensure you're in the safest position should one occur.

DRIVE-E

Enjoying more, using less.

With the perfect balance between performance and efficiency, every powertrain in a Volvo gives you on-demand power with low fuel consumption. We achieve this with Drive-E, the cutting-edge technology behind every one of our advanced diesel engines, where performance and efficiency are built in.

It's our innovative culture that enables us to create such powertrains. The D5 (235 hp) features PowerPulse, a Volvo Cars invention. It activates the turbocharger as soon as you press the accelerator to give an instant boost of acceleration from standstill and at lower speeds. Technology such as this enables us to offer the power of a much larger engine from a compact four-cylinder, so you get the perfect mix of power and efficiency.

Smaller engines lose less energy through friction so they can make every drop of fuel work harder to minimise emissions. We've used low-friction components to make them run smoother and more efficiently. Reducing size and weight frees up interior space and improves the car's handling.

Our eight-speed Geartronic™ automatic gearbox makes the most of each engine's potential. Designed to minimise power loss and maximise performance, Geartronic™ will always select the right gear for whatever is coming next, or you can choose to change gear yourself in manual mode.

To help you drive more efficiently, the Eco mode recalibrates the drivetrain for the lowest possible fuel consumption and emissions. The coast function disconnects the engine from the automatic transmission when you release the accelerator at speeds above 65 km/h, so it isn't being used to slow the car.

Our diesel are quiet and smooth for a relaxing journey, thanks to ground-breaking i-ART injection technology. By metering exactly the right amount of fuel for each cylinder, i-ART helps the engine run smoother while using less fuel. And the technology ensures it stays that way for the car's lifetime.

At Volvo Cars, by looking to the future we enhance your life today. Drive-E brings together advanced technologies to give you efficiency, performance and range – and a better drive for you.

YOUR JOURNEY BEGINS HERE.

We created the new XC60 with a single purpose: to provide you with an SUV that perfectly fits you and your lifestyle. A car that meets your expectations of a dynamic drive with refined comfort and confident design – built with care for people and the world we share.

A car that's intuitive to use and makes life less complicated, and is a pleasure to live with every day.

At the heart of your new XC60 is a dynamic, efficient powertrain. You will enjoy our latest Drive-E technology that gives you instant response and a comfortable ride. Fuel consumption and CO₂ emissions are kept low, and our powertrains already comply with future exhaust emission legislation.

Our Drive-E powertrain range includes advanced diesel engines mated to our smooth eight-speed Geartronic™ automatic gearbox. The responsive AWD all-wheel drive technology gives you an edge by increasing driving stability and traction on all road surfaces and in all weathers.

Enjoy the journey wherever it takes you.

D5 AWD

Our most powerful 235hp/480Nm diesel powertrain D5 AWD allows you to experience performance and refinement without compromises. Twin-turbo engine technology, our 8-speed Geartronic™ automatic and all-wheel drive add to instant control.

Disclaimer. The engine programme may vary from country to country. Please talk to your Volvo Car dealer for the latest information.

"Balancing performance and efficiency, every Volvo powertrain gives you on-demand power with low fuel consumption and emissions."



DRIVE. DON'T COMPROMISE.

We believe a car can be both great to drive and comfortable, so we built the new XC60 to strike that balance between control, precision and comfort. It's a car that rewards the way you drive with response and control. A car for long distances and memorable journeys. Sophisticated double-wishbone front suspension and our innovative integral axle rear suspension work together to put you in control of every drive. You get a car that responds to your commands without sacrificing your comfort.

Full air suspension makes the new XC60 even more capable. It isolates the car's body from the road & soaks up uneven surfaces. By keeping the ride height constant the air suspension increases stability, making the new XC60 easier and more predictable to control. The car body's height is adjusted according to its drive mode and speed. In Comfort or ECO drive mode, the body is lowered 10–20 mm at higher speeds, using less fuel and making it quieter. In Dynamic mode the body is lowered by 20 mm in order to enhance handling and road holding. All-wheel drive models give even greater reassurance on demanding roads.

As an option, you can choose between five drive modes that allow you to tailor the car's behaviour to your mood and find the perfect setting for the road you're on. Altering the engine, gearbox, accelerator and steering response changes the way the car behaves, and in the case of the optional active chassis with full air suspension even how it rides and handles. On rough roads, Off Road mode makes the new XC60 easier to control at the low speeds needed to tackle bad surfaces, and engages Hill Descent Control to make descending slopes safer and simpler.



Air suspension on all four wheels gives the XC60 outstanding ride comfort – the air springs absorb up imperfections in the road – and make the car stable by keeping the ride height constant, regardless of the load. With the active chassis you can alter the way the car rides and handles to suit your mood or the road.



Inscription

A HIGHER GRADE OF REFINEMENT.

We created the exclusive new XC60 Inscription to meet your highest expectations on Swedish luxury. It's a highly personal expression that evokes a strong sense of elegant refinement. Each detail is carefully selected to give you and your passengers a stylish and invigorating experience. Distinguished exterior design cues enhance the luxurious look and feel of the new XC60, while

the meticulously crafted interior with leather seats gives you ample room for a relaxed driving experience. The new XC60 Inscription epitomizes our proud heritage of human centric design. And when it comes to intelligent luxury imbued with distinctive style and fresh thinking, the new XC60 Inscription is in a class of its own – just like you.

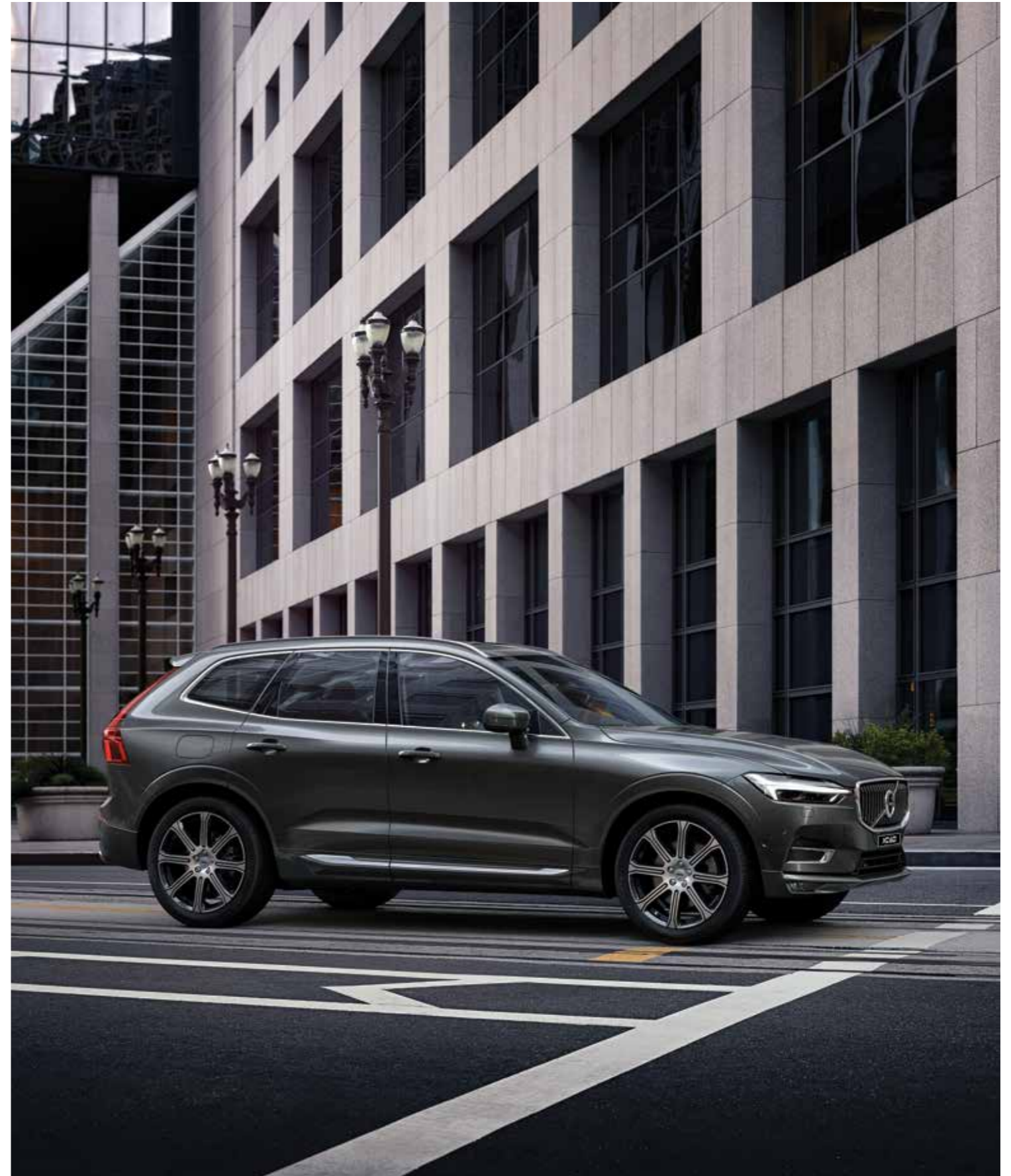



1



2



3



4

The highly sophisticated new XC60 Inscription expresses the essence of contemporary luxury. Instantly recognisable thanks to its distinctive chrome-finish grill and lower door bright deco moulding, this expression sets the new XC60 apart thanks to a number of well-judged exterior design cues that correspond with the car's timeless Scandinavian design. Just like beautifully crafted pieces of jewellery design, the ten-spoke 48.26 cm (19 inch) alloy wheels in distinctive Diamond Cut design harmonize perfectly with the dynamic and exclusive character of your new XC60 Inscription. Together with the elegant dual integrated end pipes, the wheels also contribute to the car's confident stance. Our signature LED illumination contributes to both a strong visual identity and excellent vision in the dark. And for an even better and uninterrupted light pattern, you can opt for our advanced Full-LED Active High Beam illumination technology.

On the inside, the luxurious theme continues with authentic, finely crafted materials that create a lounge-like atmosphere of sumptuous well-being. You and your passengers can lean back in sculpted power-operated comfort seats with leather upholstery. Unique

Driftwood decor inlays in genuine wood and our most advanced ambience interior illumination add to the rewarding Inscription experience. For the driver, the large 30.48 cm (12 inch) driver display and convenient drive mode settings in the console between the front seats add to your feeling of being in command. And to enhance the driving experience, our optional Active chassis with air suspension optimises comfort and handling.

For an even higher level of comfort you can upgrade to our fully power-operated front seats in Perforated Fine Nappa Leather with ventilation and an optional massage function. The four-zone climate control allows both the driver and the front seat passenger as well as the outer rear seat passenger to set their individual cabin temperature. Adding a panoramic glass roof, everyone inside your new XC60 will enjoy a superb experience of air and light – the front section can be opened at a push of button and during sunny days a power operated sunshade in perforated textile will reduce the heat and glare while maintaining the airy feel inside the cabin. Our optional high-end Bowers & Wilkins audio system brings exceptional clarity & realism to your music, wherever you are seated.



5



7



8



6



9

1. The power-operated Comfort seats with leather upholstery and the exclusive Driftwood genuine wood decor inlays add to the sensory experience of contemporary luxury. 2. Select your preferred drive mode and steering characteristics with the scroll wheel in diamond patterned metal finish. 3. The exclusive Inscription leather-clad remote control shell is in the same colour as the leather upholstery in your XC60 Inscription – an excellent example of thoughtful Scandinavian craftsmanship and clean design. 4. The XC60 Inscription with dynamic yet elegant 48.26cm (19 inch) Inscription 10-spoke alloy wheels (optional) in distinctive Black Diamond Cut design. 5. Dual integrated end pipes and optional bright decor trim add to an elegant and powerful impression. 6. The intuitive 30.48cm (12 inch) driver display with four graphic modes and the 9-inch centre display with touch screen puts you in the centre of action. 7. Inscription front grille in elegant chrome finish and the signature headlights with LED illumination. 8. The lower door bright deco moulding with Inscription logotype. 9. The lower outer grilles with chrome trim and optional fog lamps complement the elegant front design of your XC60 Inscription.

SWEDISH LUXURY, YOUR WAY.

The new XC60 Inscription is about elegant, Swedish luxury. To make your SUV an even stronger and more personal statement, you can add our exterior styling kit. Front and rear skidplates in stainless steel combined with the integrated dual split tail pipes* and body-coloured wheelarch extensions enhance your car's exclusive and

powerful presence. And adding our large 55.88 cm (22 inch) 10 open-spoke alloy wheels, you lend the elegance of your new XC60 Inscription a more rugged touch – perfectly harmonising with the stainless steel design elements of the exterior styling kit.

*Available later in 2017



Our new 55.88 cm (22 inch) wheels are the largest we've ever fitted to a production car and give the new XC60 extra width and attitude. The front and rear skidplates with integrated double tailpipes are made of stainless steel.

FOR ALL OF LIFE'S JOURNEYS.

Create a new XC60 that's perfect for your life, with Volvo accessories that are designed around you and your car.

The sleek iPad® holder complements the car's interior. It allows rear-seat passengers to watch, read or play and has two USB ports for charging devices.

Our new child seats are comfortable and stylish. They are covered with a unique Volvo fabric – Woolltextile cloth – which is 80 per cent wool, so it's both soft and durable. They also represent state-of-the-art safety: the child seat has side impact protection and is rearward-

facing for maximum safety. We apply the same stringent standards to our child seats as we do to building our cars, so you know your children are well protected. We also offer our booster cushion and backrest in a new luxurious leather and nubuck textile that is designed to match your car's interior and is easy to clean.

Your car and its load are also protected. A steel grille provides a sturdy barrier between the boot and passenger compartment and load compartment mats help protect the car's interior.



1



2



3



4



5



6



7



8

1. Protective steel grille. 2. Load compartment mat, plastic.

3. iPad® holder. 4. Child seat, infant seat. 5. Child seat, rearward-facing. 6. RedKey. 7. Child seat, booster seat. 8. Child seat, booster cushion with backrest, Leather/Nubuck Textile.

WORKS HARDER WHEN YOU NEED IT.

Make the new XC60 work for you with Volvo Cars' range of exterior accessories, designed to look good and work flawlessly. Made from tough, high-quality materials they're built to withstand the punishment inflicted by Sweden's winter. Take advantage of our range of roof-mounted accessories by adding a pair of tough, low-profile load carriers. Easy to fit (they clip onto the car's roof rails), they instantly allow you to fit our load carrier accessories, from the bike rack to a canoe holder. Our lightweight, stylish roof box fits straight onto the load carriers, adding 350 litres to the carrying capacity. Ideally suited to carrying skis (and capable of carrying up to six pairs) its low weight and Quick Grip mountings

make it possible to fit with one hand. The LED lighting in the lid helps you load in the dark. The bumper cover protects the paintwork from damage caused by loading objects into the boot. Made from stainless steel with a high gloss finish, the cover looks great and works well. The electrically folding towbar gives you the ability to tow without the inconvenience of a fixed towbar. Press a button in the boot and the towbar slides out from under the car – all you have to do is secure it into position with one click. With the electrical socket integrated into the towbar's neck it's unobtrusive and compact. There's even a bike rack to fit the towbar.



1



2



3



4



5



6



7



8

1. Bicycle holder. 2. Load carriers. 3. 22-inch five double-spoke Matt Black Diamond Cut alloy wheel. 4. 55.88 cm (22 inch) ten open-spoke Black Diamond Cut alloy wheel. 5. Bumper cover.

6. Roof box, designed by Volvo Cars. 7. Mud flaps, front. 8. Foldable towbar.

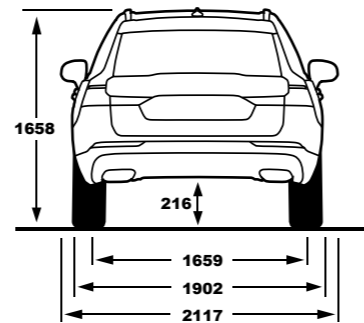
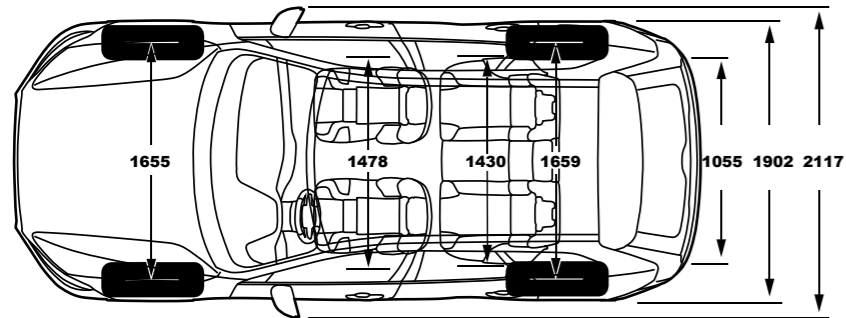
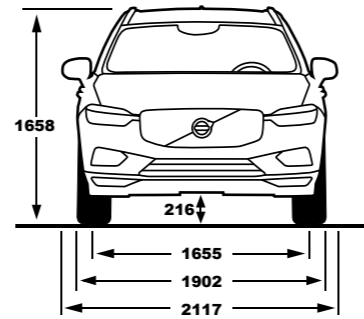
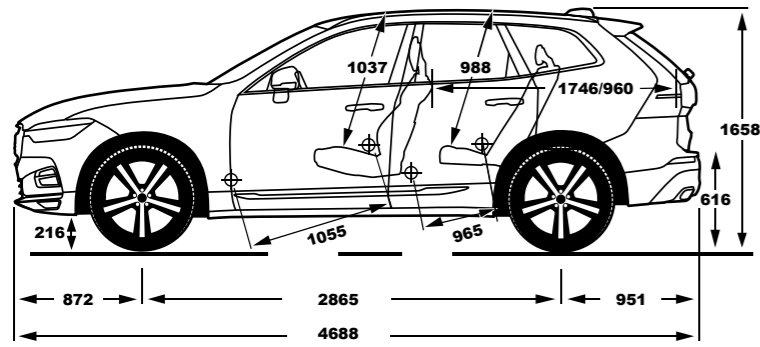

Please note: Some of the information in this brochure may be incorrect due to changes in product specifications that may have occurred since printing. Some of the equipment described or shown may now only be available at extra cost. Before ordering, please ask your Volvo Cars dealer for the latest information. The manufacturer reserves the right to make changes at any time and without notice to prices, colours, materials, specifications and models. Shot outside India, on a Volvo XC60 left-hand drive.

*Dimensions are in mm.



XC60 SPECIFICATION SHEET



UPHOLSTERIES-Perforated Fine Nappa Leather, Comfort seat (Optional) **1.** Amber in Charcoal interior (RC20) **2.** Maroon Brown in Charcoal interior (RC30) **3.** Blond in Blond/ Charcoal interior (WC00)

INLAYS 4. Driftwood

D5 Inscription

TECHNICAL DATA	
Capacity (ccm)	1969
Max output in hp	235
Max torque in Nm	480
Ground clearance (mm)	223
TRANSMISSION/ENGINE	
Automatic 8-speed AWD	S
Stop/Start	S
Top Speed (km/h)	230
Climate	
4-zone Electronic Climate Control incl. cooled glove box	S
CleanZone (Air Quality System)	S
Heated steering wheel	S
Panoramic sun roof with power operation	S
Aquablades, heated	S
Locking and security systems	
Interior motion sensor for alarm	S
Inclination sensor for alarm	S
Key remote control Inscription, leather clad	S
Keyless entry with remote tag and handsfree tailgate opening	S
Private locking	S
Power child lock, rear side doors	S
Central lock switch with diode in front and rear doors	S
Laminated Side windows	S
Instrumentation	
31 cm (12,3 inch) Driver Display	S
Seats	
Nappa leather upholstery	S
Ventilated front seats	S
Power adjustable driver & passenger seat with memory	S
Power adjustable side & lumbar support	S
Power cushion extension driver & passenger side	S
Backrest massage, front seats	S
Heated front & rear seats	S
Power fold of rear backrest from tailgate opening	S
Power folding rear headrests	S
Centre armrest with cupholders and storage	S
Interior	
Driftwood decor inlays	S
Illuminated vanity mirrors in sunvisor LH / RH side	S
Parking ticket holder	S
Leather upgrade on dashboard	S
Leather Steering wheel, 3 spoke, with unideco inlays, sport	S
Gear Shift Paddles	S
Leather gear lever knob with uni deco	S
Standard pedals	S
Netpocket on tunnel	S
Cigarette lighter / Ashtray front + Ashtray in rear doors	S
Deco Panels in Dash, Doors & Tunnel Console	S
Automatically dimmed inner and exterior mirrors	S
Carpet kit, textile	S
Sillmoulding 'Volvo' metal	S
Interior illumination high level	S
Luggage Compartment	
Temporary sparewheel T125/80R18	S
Jack	S
Power Operated Tailgate / Boot lid	S
Cargo opening scuff plate - metal	S
12V outlet in luggage area	S

*Kindly check with your local authorised Volvo Cars dealer on the exterior colour, upholstery and wheel option available for your car.

Exterior	
Bright integrated roof rails	S
Inscription grill	S
Standard mesh front	S
Bright decor side windows	S
Fully colour adapted sills and bumpers with branded Inscription	S
Colour coordinated door handles with Illumination and Puddle lights	S
Dual integrated tail pipes	S
Colour coordinated rear view mirror covers	S
Retractable mirrors	S
Foglights in front spoiler	S
LED With Active Bending Light	S
Headlight high pressure cleaning	S
Support systems	
Adaptive Cruise Control	S
Pilot Assist	S
Collision Mitigation Support, front	S
Lane Keeping Aid	S
Blind spot Information System with Cross traffic alert	S
Collision Mitigation support, rear	S
360° camera	S
Park Assist Pilot + Park Assist Front and Rear	S
Personal settings, power steering	S
Drive mode settings	S
Hill start assist	S
Hill Descent Control	S
Rainsensor	S
Graphical Head Up Display	S
Safety	
SIPS airbags	S
Inflatable curtains	S
Whiplash protection, front seats	S
Pyrotechnical pretensioners, front / rear all positions	S
Cut-Off Switch Passenger AirBag	S
Isofix - outer position rear seat	S
EBL, Flashing Brake Light and Hazard Warning	S
High positioned rear brake lights	S
Intelligent Driver Information System (IDIS)	S
Audio, Navigation & Telematics	
Premium Sound audio by Bowers and Wilkins	S
Remote control buttons in steering wheel	S
1 AUX and 2 USB connections	S
Bluetooth connection	S
CD player in centre console storage	S
Subwoofer	S
Navigation	S
Road Sign Information (RSI)	S
Smart phone integration with USB HUB (iPhone and Android)	S
Engine Installation	
Fuel tank 71 litres	S
Diesel fuel pump	S
Chassis	
Air suspension, 4 corner	S
Chassis, Four-C	S
Wheels	
48,26 cms (19 inch) - 10-Spoke Black Diamond Cut Alloy Wheel	S
Michelin V, with cavity noise damping	S
Tyre Pressure Monitoring System	S

VOLVO XC60

Exterior Colours, Trim Level, Upholsteries and Alloy Wheels



707
Crystal White Pearl



717
Onyx Black metallic



722
Maple Brown metallic



724
Pine Grey metallic



48,26cm (19 inch) 10-spoke Black
Diamond cut Alloy wheel

V O L V O