

# The GLC

Sport Utility Vehicle



Mercedes-Benz



# The GLC. Ever higher. Further ahead.

Encounter every drive on a whole new level: with the GLC. Progressive and athletic, yet virtually silent and astonishingly efficient – so much is possible with one of the most advanced SUVs in its class. Available on request for example with the plug-in hybrid drive system and AIR BODY CONTROL air suspension. Get on board: an interior that is as exquisite as it is spacious awaits you. The GLC. Make the best of every ground.

IN ITS ELEMENT IN ANY FORMAT.



Experience the GLC in thrilling HD. With the Mercedes-Benz brochure app for the iPad® and with the Digital Owner's Manual from "Mercedes-Benz Guides" for the iPhone®. Both apps feature a wealth of films and additional content and are available free of charge from the iTunes Store®.

In its element from any angle.

**2 | Mercedes-Benz GLC 250 d 4MATIC  
diamond silver metallic**

AMG Exterior and Interior line appointments, AMG multi-spoke light-alloy wheels, upholstery in ARTICO man-made leather / DINAMICA microfibre, light longitudinal-grain aluminium trim

**8 | Mercedes-Benz GLC 350 e 4MATIC  
designo diamond white bright**

EXCLUSIVE Exterior line appointments with designo interior, 5-spoke light-alloy wheels, upholstery in designo two-tone platinum white pearl/black nappa leather, black open-pore ash wood trim

**16 | Mercedes-Benz GLC 250 4MATIC  
selenite grey metallic**

EXCLUSIVE line appointments with EXCLUSIVE interior and exterior, 5-spoke light-alloy wheels, upholstery in saddle brown/black, brown open-pore ash wood trim

**58 | Mercedes-AMG GLC 43 4MATIC  
obsidian black metallic**

AMG 5-twin-spoke light-alloy wheels, upholstery in black leather with red topstitching, AMG carbon-fibre / light longitudinal-grain aluminium trim

In its element every kilometre of the way.

**24 | Mercedes me**

**28 | Services**

**32 | Engines, 9G-TRONIC and 4MATIC**

**33 | Plug-in hybrid**

**34 | AIR BODY CONTROL**

**35 | DYNAMIC SELECT, Off-Road  
Engineering package**

**36 | Driving Assistance package Plus**

**37 | Integral safety concept**

**38 | LED Intelligent Light System**

**39 | 360° camera**

**40 | Infotainment**

**42 | Spatial concept**

**44 | Equipment, packages and accessories**

**56 | Wheels**

**58 | Mercedes-AMG models**

**70 | Technical data**

**73 | Upholstery and paintwork**

The illustrations may include accessories and optional extras which do not form part of the standard specification.

A silver Mercedes-Benz SUV is shown from a side-rear perspective, driving on a city street. The street is busy with pedestrians on the sidewalk and other vehicles in the distance. The scene is set in a city with tall buildings and trees. The lighting is bright, suggesting a sunny day.

## SUV. These three letters have never sounded so good.

Radiate effortless superiority and power without appearing pushy. Stipulate the direction with pride and confidence, whilst knowing when to hold back. This is the fine art of modern luxury. And this is the design idiom of the GLC. The upright, highly expressive front end and the three-dimensionally configured radiator grille lend it a progressive presence. On the side of the vehicle precise feature lines and muscular surfaces produce an inimitably Sensual Purity, a hallmark of the new Mercedes-Benz Design.





#### LOOKING INTO THE FUTURE

---

The LED Intelligent Light System is available on request. The clearly defined contours and high-quality detailing with a three-dimensional design ensure that the vehicle has an unmistakable front view. The LEDs used are also much more durable and more efficient than conventional lights. A characteristic feature is what is known as the flare with the functions indicator, position light and daytime running lamp. The light follows the inside contours, ensuring a distinctive, exceptionally high-quality Mercedes-Benz Design during the daytime and at night.





Make the best of every drive: five different drive programs can be selected via the DYNAMIC SELECT controller on the centre console: "Comfort", "ECO", "Individual", "Sport", "Sport+". Depending on the equipment they influence factors such as the drive system, the suspension and the steering. This means that the driving experience can be optimally adapted to individual requirements or to external conditions.



Town. Country.  
And everywhere in between.







## On the road to a better world: The GLC 350 e 4MATIC.

One car length ahead of its time: the GLC 350 e 4MATIC with plug-in hybrid. The drive combination featuring a 4-cylinder petrol engine and a hybrid module facilitates purely electric driving up to a speed of 135 km/h. Over a range of up to 34 km you will be accompanied only by slight wind noise, otherwise there is peace and quiet and the good feeling that no fuel is being consumed locally and that no emissions are being produced. An exciting experience. Presented by the GLC 350 e 4MATIC.

A white SUV is shown from the rear, driving on a bridge. The bridge has a dark metal truss structure. In the background, there are several tall buildings of a city skyline under a cloudy sky. The car is moving towards the right side of the frame.

Knows only one direction: forwards.

#### CROSSWIND ASSIST

Sudden gusts of wind can take a vehicle off course, especially at high speeds. The GLC has Crosswind Assist fitted as standard to provide stability. It is part of the Electronic Stability Program ESP® and from a speed of 80 km/h it is active when driving straight ahead and during slight cornering. Braking intervention on the side of the vehicle facing the wind can assist the driver, depending on the direction and intensity of the crosswind. The influence of the wind on the car is minimised, whilst handling safety is maximised.







Sit higher. Shine deeper.

More radiance. More depth. Even more elegance and value appeal. This is the GLC in fine designo diamond white bright. With this paintwork the first, colouring layer is combined with a pearlescent effect layer on top of it. And with clear coat it is then completed to become a three-layer designo paint. Incidentally, designo diamond white bright is a perfect match for the fine designo two-tone platinum white pearl/black interior. One of many colour and material combinations which make the GLC the most personal SUV in its class.

Life in the city.  
At its best by a distance.





## Pure refinement.

Savour every metre of height – with the new AIR BODY CONTROL. The optional air suspension with continuous adjustable damping pampers the occupants using every rule of engineering artistry in the book. Understeering is tangibly reduced for a dynamic driving experience. In addition the system simply soaks up road unevenness. Automatic height regulation enhances stability and cuts fuel consumption, depending on the current speed. On stony ground or when the car is heavily laden, the vehicle height can also be manually adjusted via the level control switch. Start relaxed – arrive more relaxed: best achieved with the GLC with AIR BODY CONTROL air suspension.





Every type of ground  
is good grounds - for the GLC.





The interior of the GLC impresses with its outstandingly high quality feel. The secret behind this are the surfaces: materials such as open-pore wood, machined aluminium or perforated leather make modern luxury tangible – up close and personal.



#### THE TOUCHPAD: INTUITIVELY INNOVATIVE

Gestures are the original form of communication. They are brief and unambiguous. As if made for motoring. Because one thing above all deserves your attention whilst you're driving; the traffic around you. One or two gestures with your fingers – a quick swipe or splay – is all the newly developed touchpad with multitouch sensor system (as an option depending on the equipment) needs to understand what you want. It can even decipher the letters and numbers in your handwriting. This means that all the infotainment system's functions can be actuated using gestures. A unique haptic experience – and a perfect example of the leading-edge ergonomics in the GLC.

The image shows the rear passenger area of a Mercedes-Benz GLC. The seats are upholstered in brown leather with vertical stitching. The right-side door is open, revealing a dark interior panel with a silver handle and a circular speaker. Outside the door, a rocky coastline with waves is visible under a cloudy sky. The text "57 mm more legroom." is overlaid on the lower right portion of the image.

57 mm more legroom.

Whether you're off on a long journey with the family or on a great adventure with friends – tremendous freedom awaits you in the GLC. Tangibly more room than in the GLK predecessor model and even more variability make so much possible.



4.66 m more freedom.



## Our world in your hands.

[www.mercedes.me](http://www.mercedes.me) – it's all about you. Discover a world of fascinating services, products and innovations which will enrich your life and take the strain out of everyday mobility. Coming straight to you in digital form. And turning our world into your world.





## Life can be so fascinating when you're fully connected.

All our connectivity and mobility services plus a host of other fascinating features – all in one place and exclusively for you. That's Mercedes me. Register free of charge today and make the world of Mercedes-Benz your very own at your convenience – on your PC or laptop or in mobile mode via tablet, smartphone or smartwatch. And because your life is forever changing, our services are also continually evolving. Join us now at [www.mercedes.me/welcome](http://www.mercedes.me/welcome)

Looking for individual inspiration in real life, too? The Mercedes me Stores are a fascinating phenomenon worldwide – in Peking, Moscow and Hamburg, for example.



**Mercedes me connect** networks you with your vehicle – and your vehicle with the whole world. A comprehensive range of convenient connectivity services relating to all areas of your vehicle supports you, ensuring greater safety, closer contact and an even more fascinating driving experience. It's reassuring to stay connected all the time while you're on the move. Mercedes me connect includes Standard Services, which are able to provide you with automatic support in the event of a breakdown or an accident, and Remote Online Services – the option enabling vehicle settings to be carried out by smartphone – and lots more besides.

**Mercedes me inspire** offers special brand experiences and an opportunity to engage in an inspiring dialogue. We aim to share our ideas with you and we would like to know your ideas and wishes. So that we can always offer you the best solutions. A community is available to this end, and you will also find a growing range of offerings and experiences which go beyond the traditional vehicle-related topics – from areas such as events, travel and lifestyle.

**Mercedes me move** offers access to intelligent mobility solutions: car2go is the pioneer and global market leader in free-floating car sharing, the moovel mobility app pools the offerings from various mobility providers to find the ideal route from A to B. With the mytaxi app you can order a taxi, track its approach live and pay for your journey in a convenient manner. Mercedes-Benz Rent offers vehicles to suit all occasions for short- or long-term rental from an authorised Mercedes-Benz dealer near you. Blacklane enables you to book a chauffeur-driven limousine, FlixBus offers inexpensive, comfortable and environment-friendly trips on long-distance coaches.

**Mercedes me assist** makes easy work of organising maintenance for your vehicle, providing a convenient online means of locating a Mercedes-Benz dealer in your neighbourhood and arranging a service appointment. The digital service report keeps you up to date on performed service work at all times. The report is available to you online just one day after a service. In addition to the current service report, you can also view your vehicle's complete service history and service intervals, and you can print this information out if you so wish.

**Mercedes me finance** offers you various routes to your vehicle of choice. The Mercedes-Benz Bank/Mercedes-Benz Financial Services finds the ideal leasing, financing and insurance solution together with you – tailored to your needs. Our leasing products enable you to drive the latest models at all times while enjoying maximum flexibility, as you pay not for acquisition of the vehicle, but only for its use. You also benefit from attractive monthly instalments. Our financing arrangements enable you to pay for your new Mercedes-Benz in a way that suits your personal budget. You can tailor your monthly instalments to your needs by deciding on an appropriate down-payment and term for your contract. Our individual insurance solutions offer reliable protection for your budget and your vehicle on attractive terms. Once a contract is in place, you can conveniently manage your finance applications online.<sup>1</sup>

<sup>1</sup> Depending on market availability.

**Mercedes-Benz  
Service**



## Our service: the perfect fit for your Mercedes.

Beyond the car itself, you also acquire something priceless – an exclusive partnership with Mercedes-Benz. For you, this means safety, independence and motoring free of any worries. In other words: the reassuring feeling of driving a Mercedes.

**The best for your Mercedes.** No-one knows your Mercedes better than our experienced specialists at the Mercedes-Benz workshops. The comprehensive range of services and the high standard of quality ensure that your vehicle is in top condition. We use tested Mercedes-Benz GenuineParts and special tools to this end.

**The best for you.** Motoring free of any worries right from the word go: with the tailor-made Mercedes-Benz Service Contracts. These offer you the benefits of a reliable basis for long-term planning, permanent control over costs, fixed monthly rates and cost transparency. Plus ideal protection from additional workshop costs.

**The best for your mobility.** The Mercedes-Benz Mobilo<sup>1</sup> mobility solution provides for motoring free of any worries throughout Europe – covering breakdowns, accidents, minor mishaps and vandalism. The benefits offered by Mobilo include on-the-spot assistance, a replacement vehicle, towing and overnight hotel accommodation, for example. Mobilo comes free of charge for the first two years after initial registration and can subsequently be renewed each time the vehicle is serviced by an authorised service partner, for a period of up to 30 years in all. Whenever you need assistance, you can reach us free of charge throughout Europe on 00800 1 777 7777<sup>2</sup>.

### ↘ FIND OUT MORE

For the full information on Mercedes-Benz Service Contracts, go to [www.mercedes-benz.com/servicevertraege](http://www.mercedes-benz.com/servicevertraege) – or ask your authorised Mercedes-Benz dealer to draw up an individual offer for you.

<sup>1</sup> Our general terms and conditions apply. The period of validity is extended after each service carried out by an authorised Mercedes-Benz service partner until the due date for the next service – up to a maximum of 30 years after initial registration. <sup>2</sup> Roaming charges may apply when calling from abroad.

## What would motorsport be without Mercedes-Benz?

The first vehicle ever to win an automobile race was powered by a Daimler engine. The first Mercedes was a racing car. The Silver Arrows – a true legend. Mercedes-Benz has a long tradition of involvement with the world of sport. Motorsport shapes the brand and every vehicle bearing the Mercedes star to this day. Discover the brand's unique history first-hand: at the Mercedes-Benz Museum in Stuttgart.

### ↘ FIND OUT MORE

Discover just what has been moving the world for 130 years and take a journey through time as well as through the history of the automobile at the Mercedes-Benz Museum. More than 1500 exhibits await you on 16,500 m<sup>2</sup> of floorspace, including unique gems such as the oldest surviving Mercedes from 1902 or the legendary gull-wing models. Welcome to a place of innovation:

[www.mercedes-benz.com/museum](http://www.mercedes-benz.com/museum)

[www.facebook.com/mercedesbenzmuseum](https://www.facebook.com/mercedesbenzmuseum)

[www.instagram.com/mercedesbenzclassic](https://www.instagram.com/mercedesbenzclassic)

[www.twitter.com/mb\\_museum](https://www.twitter.com/mb_museum)

[www.google.com/+mercedesbenzmuseum](https://www.google.com/+mercedesbenzmuseum)

[www.youtube.com/mercedesbenzmuseum](https://www.youtube.com/mercedesbenzmuseum)



## What would Mercedes-Benz be without motorsport?

3 June 1934 marked the beginning of the Silver Arrows legend in the International Eifel Race at the Nürburgring. Today this legend is more alive than ever: in 2015 the Silver Arrows works team MERCEDES AMG PETRONAS won the Formula 1 constructors' and drivers' titles for the second year in a row. The value of these successes extends way beyond the race track: every mile raced advances the development of lightweight materials and hybrid technology, for example, for application in series production.

### ↘ FIND OUT MORE

Fascinating Formula 1 goes multimedia:  
[www.facebook.com/MercedesAMGF1](https://www.facebook.com/MercedesAMGF1)  
[www.twitter.com/MercedesAMGF1](https://www.twitter.com/MercedesAMGF1)  
[www.youtube.com/MercedesAMGF1](https://www.youtube.com/MercedesAMGF1)  
[www.google.com/+MercedesAMGF1](https://www.google.com/+MercedesAMGF1)  
[www.instagram.com/MercedesAMGF1](https://www.instagram.com/MercedesAMGF1)  
[www.MercedesAMGF1.com](http://www.MercedesAMGF1.com)  
[www.mercedes-benz.com/motorsport](http://www.mercedes-benz.com/motorsport)





## Energy needs change. And somebody to change it.

Numerous different engines, three different fuels, one common goal: to retain the uniquely high ride comfort of a Mercedes-Benz and at the same time to achieve astonishingly low fuel consumption and emissions. This is taken care of by a complete package of innovation, at the technological helm of which is a new transmission drive system: **9G-TRONIC** and **4MATIC**.

All the engines are paired with the new automatic transmission 9G-TRONIC as standard (7G-TRONIC PLUS in the case of the GLC 350 e 4MATIC). A milestone in the field of transmission technology. With nine forward gears, this automatic transmission combines efficiency, comfort and dynamics at an entirely new level. Even faster gear changes and smoother gear shifting make it an enticing proposition. At the same time, the 9G-TRONIC helps to reduce fuel consumption. The combination of 9G-TRONIC and the all-wheel drive system 4MATIC is also entirely new. A compact design and numerous lightweight design measures lower emissions further still – without any compromises where ride comfort, driving dynamics or safety are concerned.

### THE ENGINE RANGE

---

#### Diesel:

GLC 220 d 4MATIC with an output of 125 kW (170 hp) and peak torque of 400 Nm

GLC 250 d 4MATIC with an output of 150 kW (204 hp) and peak torque of 500 Nm

GLC 350 d 4MATIC with an output of 190 kW (258 hp) and peak torque of 620 Nm

---

#### Petrol:

GLC 250 4MATIC with an output of 155 kW (211 hp) and peak torque of 350 Nm

GLC 300 4MATIC with an output of 180 kW (245 hp) and peak torque of 370 Nm

GLC 350 e 4MATIC, petrol engine with 155 kW (211 hp) and peak torque of 350 Nm, electric motor with 85 kW (116 hp) and peak torque of 340 Nm, system output of 235 kW (320 hp) and peak torque of 560 Nm

---



### GLC 350 e 4MATIC

The PLUG-IN HYBRID technology facilitates rapid external charging from 20 to 100%<sup>1</sup> via a wallbox in just two hours, taking a good four hours via a normal socket.

- 1 | 4-cylinder petrol engine.
- 2 | Recuperative braking system.
- 3 | Electric motor.
- 4 | Lithium-ion high-voltage battery.
- 5 | Battery charging socket.

<sup>1</sup> Charge time 20–100%, varies depending on power source between 2.0 and 4.1 h (400 V/16 A–230 V/8 A).

## GLC 350 e 4MATIC with plug-in hybrid technology.

The GLC 350 e 4MATIC makes the best of every drive system: power, serenity and extreme efficiency. The drive unit consists of a 4-cylinder combustion engine with 155 kW (211 hp) and a maximum torque of 350 Nm plus a hybrid module with 85 kW (116 hp) and a maximum torque of 340 Nm. Purely electric driving is possible with a maximum speed of up to 135 km/h and over a distance of up to 34 km. When driving faster or on steep inclines, the GLC changes over to combustion-engine mode fully automatically.

The plug-in hybrid technology also facilitates charging at a conventional socket with 3.0 kW from 20 to 100% in a good four hours. As soon as you take your foot off the accelerator pedal whilst driving, the battery even charges automatically thanks to an intelligent operating strategy, and the car can thus achieve a local CO<sub>2</sub> emissions figure of 0 g/km.

**MANY HAVE HYBRID.**

**ONLY ONE HAS INTELLIGENT HYBRID**

**Intelligent HYBRID** is the foresighted operating strategy for Mercedes-Benz hybrid vehicles, designed to make the most efficient possible use of the electric drive system. It comprises the following functions, depending on the equipment: **radar-based recuperation** additionally uses the data from the proximity control to make the best possible use of recuperation and the “gliding” function. A **fore-sighted shift strategy** additionally uses the data from the proximity control for gear selection. A **route-based operating strategy** uses the data from the navigation system to optimise the hybrid drive operating modes to make the best possible use of the battery charge. An **ECO assistant** aids the driver in adopting an efficient driving style with the help of a haptic accelerator pedal.



## Comfort in the air. AIR BODY CONTROL.

The GLC cushions the occupants so that they almost feel as though they are travelling on air. Via **AIR BODY CONTROL air suspension**. It ensures outstanding ride comfort even when the vehicle is fully laden. Through automatic height regulation, depending on the current speed, the fuel consumption can be reduced and handling safety enhanced. In addition the ground clearance can be increased on rough roads or on difficult climbs using the level adjustment switch. Without restricting comfort the AIR BODY CONTROL also improves a dynamic driving style. Springing and damping forces are thus adapted fully automatically during evasive manoeuvres. This helps ensure that the car remains calm and controllable even in critical situations. The dampers at the front and rear axle are continuously adjustable. The air springs can be set at three stages of tautness. Using the controller for DYNAMIC SELECT the driver can select totally different driving characteristics by choosing modes that place the emphasis on comfort or sport. An extremely pleasant side effect of the AIR BODY CONTROL air suspension: when at a standstill the driver can lower the tail end of the car by 40 mm in order to make loading and unloading easier. The switch for lowering the car is located on the left-hand side wall in the load compartment.

### SUSPENSION AND STEERING

---

The standard-fit **AGILITY CONTROL suspension** with a selective damping system ensures balanced ride comfort by optimising ride characteristics, damping effect and stabilisation according to the road surface conditions.

---

The **Direct-Steer system** supplements the comfort of speed-sensitive power steering with a variable ratio dependent on the steering angle. On winding roads, for example, this produces a more agile handling response and improved straight-line stability.

---

The optional **sports suspension** facilitates dynamic driving through a tauter configuration of the springing and damping – without any major concessions where comfort is concerned.

---



## Emotions at the press of a button. DYNAMIC SELECT.

Comfortable, sporty or entirely individual suspension settings can be called up with the **DYNAMIC SELECT** controller in the centre console. The “Comfort” drive program enables particularly harmonious driving. “ECO” adjusts all parameters for low fuel consumption, the ECO display in the multifunction display supports an efficient driving style, and depending on the engine variant the “gliding function” can be activated. “Sport” is characterised by additionally lowered suspension, sportily taut damper tuning (in conjunction with optional AIR BODY CONTROL respectively), a more direct steering feel plus modified shift points. “Sport+” means extremely sporty shifting and damping characteristics. The “Individual” drive program allows the

driver to vary individual parameters at will – from the steering and the drive system to the suspension. The lavish showcasing of the selected drive program via the media display is an experience in its own right.

In conjunction with the optional **Off-Road Engineering package**, DYNAMIC SELECT is equipped with up to five further preconfigured drive programs for even better off-road capability. These are operated using the Downhill Speed Regulation or the off-road switch block, the controller and the touchpad. The off-road settings facilitate an optimum vehicle configuration even in less than optimum external conditions. The selectable programs are:

“Slippery”, “Off-road”, “Trailer”, “Incline” and, in conjunction with AIR BODY CONTROL, what is known as “Rocking Assist”, in case the car should become stuck in deep mud, for instance.

## Driving Assistance package Plus. Minus dangers.

Intervening where necessary. Holding back where possible. This effortless superiority is part of the optional **Driving Assistance package Plus**. It combines safety and assistance systems which relieve the burden on the driver, reduce the risk of accidents, and improve protection of the occupants and other road users. Particularly in urban traffic, the Brake Assist **BAS PLUS** with Cross-Traffic Assist and the **PRE-SAFE® Brake** can reduce the risk of collisions at junctions and rear-end collisions as well as accidents involving pedestrians. The **Active Lane Keeping Assist** and **Active Blind Spot Assist** can provide assistance if the car inadvertently drifts out of its lane or if the danger of collision with other vehicles arises when changing lanes. One-sided brake actuation can help return the vehicle to its lane and prevent an accident. **PRE-SAFE® PLUS** expands the **PRE-SAFE®** preventive occupant protection system to include protective measures in the event of an imminent rear impact. **DISTRONIC PLUS with Steering Assist and Stop&Go Pilot** can help the driver to maintain a safe distance from the vehicle in front and stay in the centre of the lane.

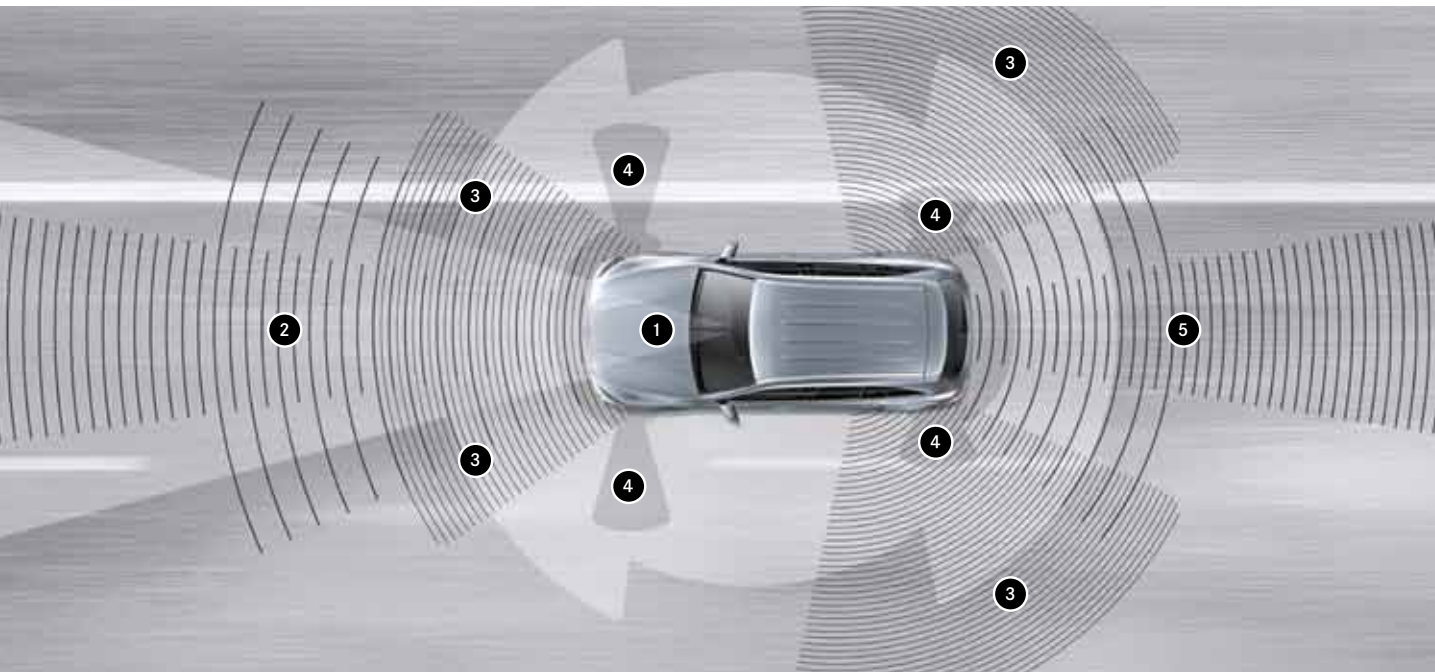

### MERCEDES-BENZ INTELLIGENT DRIVE

A stereo camera, short- and long-range radars, and all-round sensor systems form the basis for numerous safety and assistance systems in the GLC.

- 1 | Stereo multi-purpose camera.
- 2 | Long-range radar with intermediate range sensing.
- 3 | Short-range radar.
- 4 | Ultrasonic sensors.
- 5 | Multi-mode radar.

# The reassuring feeling of driving a Mercedes-Benz.

We are the first automotive manufacturer worldwide to have developed an **integral safety concept**. Aimed at avoiding accidents, ensuring ideal responses to dangers and lessening the consequences of accidents. For the occupants of a Mercedes and for all other road users, too.

## SAFE DRIVING

---

The **drowsiness detection system ATTENTION ASSIST** can enhance driving safety, in particular on long trips and when driving at night. It can monitor the steering behaviour of the driver to detect typical signs of drowsiness and severe loss of attention, and give a visual and acoustic warning of impending microsleep.

The **ADAPTIVE BRAKE** control system improves braking performance through intelligent intervention: in wet conditions, the brake discs are kept dry. The brake pads are applied automatically when the driver's foot is removed abruptly from the accelerator pedal. And on uphill slopes, the system is able to prevent the vehicle from rolling backwards.

The optional **DISTRONIC PLUS proximity control** helps to maintain a safe distance from the vehicle in front above all in stop-and-go traffic. The system is able to brake the vehicle automatically and subsequently accelerate again.

## IN THE EVENT OF DANGER

---

When a danger of a rear-end collision arises, the **COLLISION PREVENTION ASSIST PLUS** function is able to initiate partial braking in order to avoid a collision or to mitigate the consequences.

The optional **Blind Spot Assist** with radar sensors makes one of the major hazards in traffic visible. When a vehicle is detected in the blind spot, a red triangle lights up in the exterior mirror. An acoustic warning additionally sounds as necessary. The system is active at speeds between 30 and 250 km/h. The optional **Lane Keeping Assist** is able to detect when the vehicle is unintentionally drifting out of its lane at speeds between 60 and 200 km/h, duly warning the driver by means of pulsed vibrations on the steering wheel. Blind Spot Assist and Lane Keeping Assist also form part of the optional **Lane Tracking package**.

The optional **PRE-SAFE® occupant protection system** is able to identify critical driving situations in advance and to initiate precautionary measures to protect the car's occupants if an accident appears imminent. Such measures include reversible belt tensioning or automatic closing of open side windows, for example.

## IN AN ACCIDENT

---

A comprehensive protection system can reduce the risk of injury for occupants and other road users. This includes the **active bonnet**, which can automatically spring up a few centimetres in the event of a collision and thus help to protect pedestrians or cyclists. The car occupants can also be extensively protected by up to **nine airbags** (two of which are optional sidebags in the rear).

## AFTER AN ACCIDENT

---

Every Mercedes-Benz is optimally trained in first aid. If the worst comes to the worst, the engine can be switched off automatically and the central locking unlocked, plus the hazard warning lights and emergency interior lighting can be activated. Finally the **Mercedes-Benz emergency call system** (country-specific) integrated as standard can send GPS position data and important vehicle information, though it is to be hoped this will never be necessary.



## Radiates pure intelligence.

The optional LED **Intelligent Light System** impresses sustainably. With an unmistakable design, very low energy consumption and a long lifespan. But above all it offers even more vision and safety. When turning or cornering, the low-beam headlamps automatically adapt to the light and driving conditions. And with blue LED locator lighting the “Coming Home” function welcomes the driver when they lock and unlock the car via the radio remote control key. The optional Adaptive Highbeam Assist Plus distributes the light in such a way that oncoming traffic is not dazzled, but the road surface is always optimally illuminated.

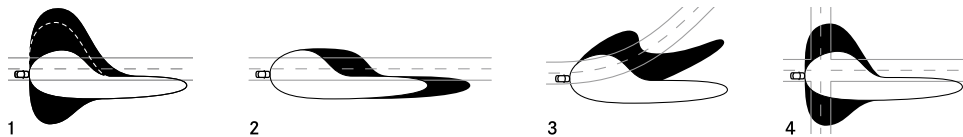

### LED INTELLIGENT LIGHT SYSTEM

The **LED Intelligent Light System** in concrete terms: **1** | On country roads the left-hand edge of the road is much better illuminated, in particular when the fog lamps are switched on. **2** | On motorways the visibility range is increased by up to 60 percent. **3** | The active light function enhances safety on bends. **4** | The cornering light enhances safety when turning at junctions due to better lateral illumination. The extended fog lamp function reduces dazzling of the driver due to light reflected by the fog. To supplement this the **Adaptive Highbeam Assist** is available on request: when main beam is switched on it facilitates an optimum headlamp range without dazzling oncoming traffic.

### MORE LIGHT

The optional **Adaptive Highbeam Assist Plus** facilitates driving with main-beam headlamps on permanently, without dazzling other road users. As a result the best possible headlamp range is always available to the driver. The function is active from a speed of 30 km/h on unlit roads.



## Shows you more of the world.

The optional **360° camera** makes parking and manoeuvring with a realistic all-round view possible with the help of four networked short-range cameras. A bird's-eye view of the vehicle and its surroundings can be displayed on the screen of the optional COMAND Online control and display system. Obstacles below the window line are also visible to the driver. This is helpful, for example, when approaching kerbs. One camera is centrally mounted in the radiator grille at the front; there is one in each exterior mirror and another one in the centre of the boot lid. In various views, additional guide lines are displayed to make parking easier. The display also shows the vehicle's range of movement for the current steering angle. The views change automatically, for example when changing from forward to reverse gear, and can also be individually selected.



### PARKING – NOTHING COULD BE EASIER

The optionally available **Active Parking Assist with PARKTRONIC** makes it easier to find a parking space and also to enter or leave parking spaces. When activated, it automatically steers the vehicle into perpendicular and parallel parking spaces, relieving the driver of the work of steering and braking.

Reverse parking and manoeuvring is considerably easier and safer using the optional **reversing camera**. Protected by a flap, it is automatically activated when reverse gear is engaged and shows the driver the surroundings behind the vehicle with dynamic guide lines on the media display.

## Sense and sensuality. The infotainment in the GLC.

Keep an overview of key driver information without taking your eyes off the road – thanks to the optional **Head-up Display**. It projects a virtual image (approx. 21 x 7 cm) within the driver's field of vision. This image appears to float over the bonnet around two metres ahead of the driver. The information is displayed in high-resolution and in colour. Depending on the equipment, the information displayed may include navigation tips, speed, speed limits or settings for cruise control or **DISTRONIC PLUS**, for example.

All the information at a glance, incredible sound for the ears. Enjoy the optional **Burmester® surround sound system**. An exceptional sound experience composed of 13 high-performance loudspeakers, a 9-channel DSP amplifier and an output of 590 watts. Perfectly tuned electronic and acoustic components that turn the interior into a concert hall. Whether you are sitting in the front or the rear, the surround function creates a 3D feel-good sound.

### MULTIMEDIA IN THE GLC

Navigation, telephone, audio, video, internet – all this is part of the optional **COMAND Online** control and display system. Information is shown in high resolution and in colour on a 21.3 cm (8.4-inch) central display. Operation via the new touchpad is easy and intuitive.

The **Audio 20 USB** multimedia system with a 17.8 cm (7-inch) media display is internet-capable and enables networking with mobile devices via Bluetooth®. Optionally available as Audio 20 CD with 17.8 cm (7-inch) media display including navigation pre-installation. Also available with a touchpad on request.

User-friendly navigation, accurate map data and excellent route guidance – the optional **Garmin® MAP PILOT** transfers all the advantages of a Garmin® navigation system to the Audio 20 CD, with a touchpad available on request.







## A climate with a special feel.

With its large glazed areas the optional **panoramic sliding sunroof** ensures a particularly light and friendly ambience. It consists of a fixed glass roof at the rear and an electrically operated sliding glass roof at the front. Two electric sunblinds provide shade from strong sunlight. In the raised position, the sliding glass roof automatically adjusts to three tilt positions to suit the current road speed. The glass roof is lowered at high speeds, reducing the noise level and air circulation in the interior. Conversely, it raises itself again at low speeds.

The optional **AIR-BALANCE package** allows completely individual fragrancing of the interior. There is a choice of four high-quality interior fragrances according to personal preference and mood. In addition, the air quality can be improved by ionisation and optimised filtering of the incoming and recirculating air.

### LOADING LUXURY

---

The optional **EASY-PACK tailgate** can be opened and closed at the touch of a button for more convenient loading and unloading of the load compartment.

---

The **load compartment** is one of the most spacious in the segment. A maximum load compartment volume of 1600 l is available for loads when the rear seat backrests are completely folded down. The larger dimensions of the load compartment opening and load compartment width make loading and unloading easier. To enable more convenient use of the load compartment there are multifunction rails on the left and right in the side panelling. Depending on the equipment, this is where the switches for unlocking the rear seat backrests and lowering the boot sill, as well as bag hooks and a 12 V socket are positioned.

---







## The standard equipment.

Comprehensive safety equipment unique in this class. Comfort features which make every journey that little bit more pleasant. Lots of useful details and extremely high-quality workmanship. All this is on board the GLC as standard. For responsible, thrilling and luxurious driving, day after day.

### EXTERIOR HIGHLIGHTS

---

Front bumper painted in the vehicle colour featuring simulated underguard in matt iridium silver

---

Radiator trim with two louvres in matt iridium silver

---

Window weatherstrips in black

---

Rear bumper in the vehicle colour featuring a simulated underguard in matt iridium silver

---

10-spoke light-alloy wheels, painted vanadium silver, with 235/65 R 17 tyres (GLC 350 e 4MATIC with 235/60 R 18 tyres)

---

### INTERIOR HIGHLIGHTS

---

Seats upholstered in black Aberdeen fabric

---

3-spoke multifunction steering wheel in black leather

---

Dashboard in black with nozzle surrounds in black

---

Instrument cluster with 13.97 cm (5.5-inch) multifunction display

---

Centre console in black with trim in black piano-lacquer look

---

Roof liner in crystal grey fabric

---



## The EXCLUSIVE Exterior and Interior line.

A glittering appearance: with lots of chrome, fine-grained man-made leather and beautifully structured wood trim, the EXCLUSIVE design and equipment line radiates a very special feeling of modern luxury.

### EXTERIOR HIGHLIGHTS

---

Radiator trim with two louvres in matt iridium silver with chrome inserts

---

Simulated underguard front and rear in chrome

---

Beltline trim strip and window weatherstrip in polished aluminium

---

Roof rails in anodised aluminium, flush-fitting

---

5-spoke light-alloy wheels, painted vanadium silver with a high-shine finish, with 235/60 R 18 tyres

---

Exhaust system with two visible stainless steel tailpipe trims, mounted in the bumper, or two decorative tailpipe trims (for diesel models)

---

### INTERIOR HIGHLIGHTS

---

Seats with exclusive seat upholstery layout in ARTICO man-made leather/ Grenoble fabric in black or black/espresso brown

---

3-spoke multifunction steering wheel in black or espresso brown leather

---

Upper dashboard section and beltlines in ARTICO man-made leather with contrasting topstitching

---

High-gloss brown line structure lime wood trim

---

Fabric roof liner available in crystal grey, black or porcelain

---







## The AMG Exterior and Interior line.

On request the AMG Exterior and Interior lines ensure more than a mere touch of sportiness. Performance-oriented design, exclusive features borrowed from motorsport and high-tech components emphasise the S in SUV.

### PURE AMG

Experience the true thrill of AMG starting on page 58.

#### EXTERIOR HIGHLIGHTS

---

AMG bodystyling, comprising simulated AMG underguard front/rear with insert in chrome

---

Radiator trim with two louvres in matt iridium silver with chrome inserts

---

Beltline trim strip and window weatherstrip in polished aluminium

---

Roof rails in anodised aluminium, flush-fitting

---

AMG 5-twin-spoke light-alloy wheels, painted titanium grey with a high-sheen finish, with 235/55 R 19 tyres

---

#### INTERIOR HIGHLIGHTS

---

Seats with exclusive seat upholstery layout in ARTICO man-made leather/DINAMICA microfibre and grey contrasting topstitching

---

3-spoke multifunction sports steering wheel in black leather, flattened bottom section, with steering-wheel gearshift paddles

---

Light longitudinal-grain aluminium trim

---

Roof liner in black

---

Brushed stainless steel AMG sports pedals with black rubber studs

---



## The OFF-ROAD Exterior line.

How it all began: the OFF-ROAD design and equipment line with striking design elements awakens a sense of adventure and cites the already legendary off-road expertise of Mercedes-Benz. The Off-Road Engineering package additionally available as an option is the perfect supplement for genuine off-road capability.

### EXTERIOR HIGHLIGHTS

---

Front bumper with larger angle of approach

---

Radiator trim with two louvres in matt iridium silver with chrome inserts

---

Simulated underguard front and rear in chrome

---

Beltline trim strip and window weatherstrip in polished aluminium

---

Roof rails in anodised aluminium, flush-fitting

---



---

5-spoke light-alloy wheels, painted tremolite grey with a high-sheen finish, with 235/60 R 18 tyres

---

Exhaust system with two visible stainless steel tailpipe trims, mounted in the bumper, or two decorative tailpipe trims (for diesel models)

---





## designo.

Whether it's bathed in elegant black or in fine platinum white pearl – transform the interior of the GLC into a thrillingly exclusive place. With the designo equipment packages. Nappa leather of matchless high quality, special trims and a wealth of extraordinary detailing pamper the occupants using every trick in the book of craftsmanship.

### **designo two-tone interior in platinum white pearl/black**

---

Seats in designo nappa leather in platinum white pearl/black with diamond design and white topstitching

---

“designo” badge in the backrests of the front and rear seats

---

3-spoke multifunction sports steering wheel in black leather

---

Upper part of dashboard and beltlines in ARTICO man-made leather in black with contrasting topstitching in crystal grey

---

Door centre panels and door armrests each in platinum white pearl in a diamond design with white topstitching

---

### **designo interior in black**

---

Seats in black designo nappa leather in a diamond design with crystal grey contrasting topstitching

---

“designo” badge in the backrests of the front and rear seats

---

3-spoke multifunction steering wheel in black leather

---

Upper part of dashboard and beltlines in ARTICO man-made leather in black with contrasting topstitching in crystal grey

---

Centre armrest in black with contrasting topstitching in crystal grey

---

Door centre panels in black in a diamond design with contrasting topstitching in crystal grey

---



## The Night package.

The Night package (optional in conjunction with EXCLUSIVE Exterior line or AMG Exterior line) underlines the sportily expressive character of the GLC with a wealth of design elements in black. Be it the wheels, trim or windows – everything appears a little more distinctive.

### EXTERIOR HIGHLIGHTS

---

Radiator trim with two louvres in high-gloss black with chrome inserts

---

Underguard front and rear painted in black

---

Exterior mirrors painted in high-gloss black

---

Beltline trim strip and window weatherstrip in high-gloss black

---

Heat-insulating dark-tinted glass starting from the B-pillar

---

Roof rails powder-coated in black matt

---



---

5-spoke light-alloy wheels, painted black with a high-sheen finish, with 235/55 R 19 tyres (in conjunction with EXCLUSIVE Exterior line), optional: 5-spoke light-alloy wheels, painted black with a high-sheen finish, with 255/45 R 20 tyres

---

AMG 5-twin-spoke light-alloy wheels, painted high-gloss black with a high-sheen finish, with 235/55 R 19 tyres (in conjunction with AMG Exterior line), optional: AMG multi-spoke light-alloy wheels, painted high-gloss black with a high-sheen finish, with 255/45 R 20 tyres

---



## Optional extras.

Whether it's fine details, a unique atmosphere or ingenious technical solutions – the possibilities are virtually endless. Take a look round, here in the brochure, in the price list or at [www.mercedes-benz.com](http://www.mercedes-benz.com). Customise the GLC to suit your very own individual style.



---

1 In addition to their distinctive look, the LED High Performance headlamps boost safety at night thanks to broad light distribution, a daylight-simulating colour temperature and low energy consumption. The tail lights feature LED technology and create a visual highlight while improving visibility.

---

2 For optimum visibility on country roads and motorways, when turning or cornering, the **LED Intelligent Light System** automatically adapts to light and driving conditions. In addition to a striking look, LED technology features greater luminosity while producing less glare.

---

3 With its pleasant, indirect light the **ambient lighting** creates a unique atmosphere of wellbeing. Three different colours and five dimming levels are available to create the desired lighting mood.

---

4 The optional **EASY-PACK tailgate** can be opened and closed at the touch of a button for more convenient loading and unloading of the load compartment.

---

5 **Panoramic sliding sunroof**: with its large glazed areas, this roof system creates a particularly bright and welcoming ambience in the interior. It consists of a fixed panoramic glass rear section and an electrically operated sliding glass front section for ventilation of the interior as required.

---



## Genuine accessories.

The range of genuine accessories is as extensive as the variety of routes you'll drive. Each accessory product has been specifically developed for the GLC in accordance with the high Mercedes-Benz quality standards. Discover the entire range at [www.mercedes-benz-accessories.com](http://www.mercedes-benz-accessories.com)

1  
3

2

1 Lockable **rear-mounted cycle rack** for transporting two or three cycles as required. Convenient mounting on the trailer coupling. Maximum payload capacity of up to 30 kg per cycle rail, therefore suitable for most e-bikes. Thanks to a roller mechanism the boot can still be opened. The rack can be folded for space-saving storage.

2 The **roof spoiler** lends the car a more dynamic and sportier appearance, without restricting the field of vision in the rear-view mirror. A high-quality base coat makes the paint finish in the desired colour possible. **Rear trim strip**, chrome-plated with high-gloss finish. Matches all your car's chrome trim.

3 The **roof box** is made of extremely durable material and lockable on both sides. It has a capacity of approx. 330 l, the maximum payload is 50 kg (please bear in mind the permissible roof load of your car here).

**Alustyle Easy-Fix basic carrier bars for roof rails.** Multifunction aluminium carrier bars, with a newly developed aerodynamic profile taken from aviation design, which noticeably reduce wind noise and go perfectly with your Mercedes-Benz. Basic carrier bars precisely adapted to your car's body as the basis for a range of Mercedes-Benz transport solutions, e.g. roof boxes, ski and snowboard racks or cycle racks. Crash-tested. Lockable.





## Wheels.

Wheels are indispensable from a purely factual point of view, of course. But on an emotional level, too, the choice of wheels is an absolutely crucial ingredient of many people's dream car. We understand this and would like to make choosing from our range as difficult as possible for you.

### STANDARD EQUIPMENT AND OPTIONAL EXTRAS

25R 10-spoke light-alloy wheels, painted vanadium silver, with 235/65 R 17 tyres (standard equipment for GLC 220 d 4MATIC, GLC 250 d 4MATIC and GLC 250 4MATIC)

R04 5-twin-spoke light-alloy wheels, painted tremolite grey with a high-sheen finish, with 235/65 R 17 tyres (option)

R41 10-spoke light-alloy wheels, painted vanadium silver, with 235/60 R 18 tyres (option; standard equipment for GLC 350 e 4MATIC)

R96 5-spoke light-alloy wheels, painted vanadium silver, with 235/60 R 18 tyres (option; part of EXCLUSIVE Exterior line)

R31 5-spoke light-alloy wheels, painted tremolite grey with a high-sheen finish, with 235/60 R 18 tyres (option; part of the OFF-ROAD line)

R26 10-spoke light-alloy wheels, painted matt himalayas grey, with 235/55 R 19 tyres (option)

48R 5-spoke light-alloy wheels, painted tremolite grey with a high-sheen finish, with 235/55 R 19 tyres (option)

75R Multi-spoke light-alloy wheels, painted tremolite grey with a high-sheen finish, with 235/55 R 19 tyres (option)

R39 5-spoke light-alloy wheels, painted black with a high-sheen finish, with 235/55 R 19 tyres (part of Night package with EXCLUSIVE Exterior line; not available for AMG line)

41R 5-twin-spoke light-alloy wheels, painted tremolite grey with a high-sheen finish, with 255/45 R 20 tyres (option)

R61 5-spoke light-alloy wheels, painted tremolite grey with a high-sheen finish, with 255/45 R 20 tyres (option)

### EX-FACTORY ACCESSORIES

29R 5-spoke light-alloy wheels, painted black with a high-sheen finish, with 255/45 R 20 tyres (option)

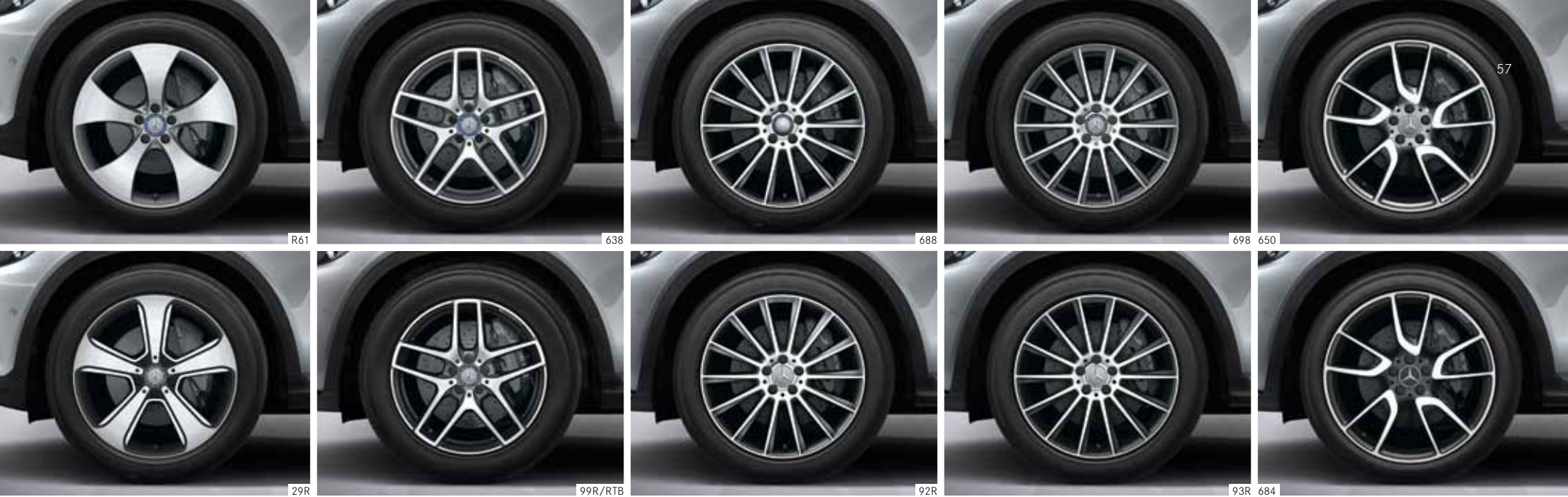

## AMG

638 AMG 5-twin-spoke light-alloy wheels, painted titanium grey with a high-sheen finish, with 235/55 R 19 tyres (part of AMG Exterior line)

99R AMG 5-twin-spoke light-alloy wheels, painted high-gloss black with a high-sheen finish, with 235/55 R 19 tyres (option and part of Night package with AMG Exterior line)

RTB AMG 5-twin-spoke light-alloy wheels, painted high-gloss black with a high-sheen finish, with 235/55 R 19 (front axle) and 255/50 R 19 (rear axle) tyres (standard equipment for Mercedes-AMG GLC 43 4MATIC)

688 AMG multi-spoke light-alloy wheels, painted titanium grey with a high-sheen finish, with 255/45 R 20 tyres (option for AMG Exterior line)

92R AMG multi-spoke light-alloy wheels, painted titanium grey with a high-sheen finish, with 255/45 R 20 (front axle) and 285/40 R 20 (rear axle) tyres (option for Mercedes-AMG GLC 43 4MATIC)

698 AMG multi-spoke light-alloy wheels, painted high-gloss black with a high-sheen finish, with 255/45 R 20 tyres (option for AMG Exterior line)

93R AMG multi-spoke light-alloy wheels, painted high-gloss black with a high-sheen finish, with 255/45 R 20 (front axle) and 285/40 R 20 (rear axle) tyres (option for Mercedes-AMG GLC 43 4MATIC)

650 AMG 5-twin-spoke light-alloy wheels, painted titanium grey with a high-sheen finish, with 255/40 R 21 (front axle) and 285/35 R 21 (rear axle) tyres (option for Mercedes-AMG GLC 43 4MATIC)

684 AMG 5-twin-spoke light-alloy wheels, painted high-gloss black with a high-sheen finish, with 255/40 R 21 (front axle) and 285/35 R 21 (rear axle) tyres (option for Mercedes-AMG GLC 43 4MATIC)

### ↘ FURTHER WHEELS

can be found in our accessories range. Information on the range of Mercedes-Benz Genuine Accessories is available at [www.mercedes-benz-accessories.com](http://www.mercedes-benz-accessories.com) or from your authorised Mercedes-Benz dealer.

# Exceptional. Athlete. The Mercedes-AMG GLC 43 4MATIC.

Mercedes-AMG is not just a producer of performance vehicles, AMG is a promise. A promise to always go one step further. To expect a lot and give everything. This is how we create extraordinary cars for extraordinary people.

And how we have come up with something completely new. An SUV with irresistible sports-car character. Welcome to the family, Mercedes-AMG GLC 43 4MATIC.

Welcome to the world of AMG.



# Winner. By nature.

Whether it's a sprint or a test of endurance, the V6 twin-turbo engine in the new Mercedes-AMG GLC 43 provides plenty of power in any situation. With an output of 270 kW (367 hp), the engine boasts a peak torque of 520 Nm and accelerates from 0 to 100 km/h in 4.9 seconds. AMG DYNAMIC SELECT ensures a perfect ride, allowing you to adjust the car's settings to suit your mood, from comfort and efficiency to extremely sporty. Plus you can choose the accompanying soundtrack. Not from your sound system's high-end speakers, but from the adjustable AMG sports exhaust system, which adapts its sound to the selected drive program. Sounds like driving pleasure. In any situation.









## Sport. Inspires.

High-performance athletes cannot conceal their potential. It's immediately obvious. Just like in the case of the Mercedes-AMG GLC 43. The distinctive front end features the hallmark AMG A-wing apron, large cooling air intakes and the AMG diamond radiator grille. The exclusive diamond radiator grille with chrome inserts and pins in chrome is a particular visual highlight. A mere look at the Mercedes-AMG GLC 43 can render somebody speechless.

# Power. Space.

Even a high-performance athlete needs the right equipment. Which is why the driver of the Mercedes-AMG GLC 43 can expect everything from his or her cockpit: high-quality workmanship, first-class design and perfect handling. The optionally available AMG performance steering wheel in nappa leather/DINAMICA microfibre, for example, offers perfect grip – even for the most sporty driving manoeuvres. Essential driving information is always on view in the AMG instrument cluster. You might never want to get out again.





# Fighter. Heart.

Keep up the pace. Brief deceleration. Full acceleration. An engine in a true Mercedes-AMG has to meet all your requirements. To the very highest standard. That's why the 3.0-litre V6 twin-turbo engine in the Mercedes-AMG GLC 43 features state-of-the-art injection technology – for lower fuel consumption and enhanced driving dynamics. To give this dynamism complete expression, the electronically controlled AMG sports suspension interacts perfectly with AMG performance 4MATIC. In short: a high concentration of technology that sets standards in the SUV segment.

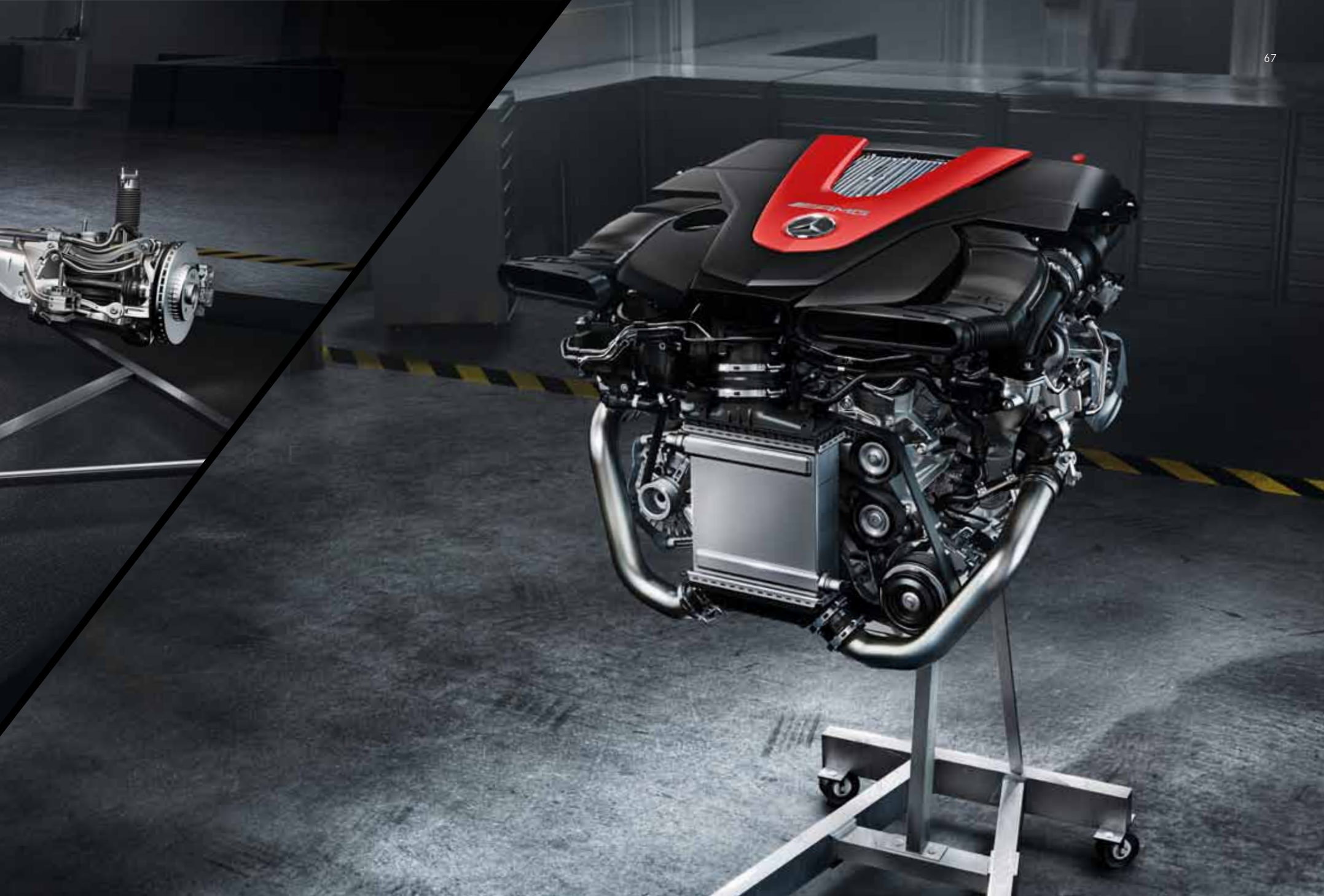





Passion grows when it is shared: the AMG Private Lounge is our community centred around the world of AMG. This is where AMG customers meet at top-class events and on the online platform exchange views about the latest developments from Affalterbach. They benefit from special offers and from a direct connection with the AMG headquarters: [www.mercedes-amg.com/privatelounge/welcome](http://www.mercedes-amg.com/privatelounge/welcome)

The AMG Driving Academy stands for an incomparable team spirit: experience performance with like-minded drivers and improve your driving skills on race tracks and at lifestyle events held at breathtaking locations around the world. Become a part of the “World’s Fastest Family”: [www.mercedes-amg.com/driving-academy](http://www.mercedes-amg.com/driving-academy)

Do you want even more? AMG offers a platform for professional motorsport with the AMG Customer Sports Programme – and a racing car designed specifically for this in the shape of the Mercedes-AMG GT3. A fully integrated service world gives you motorsport at the highest level: [www.mercedes-amg.com/customersports](http://www.mercedes-amg.com/customersports)

In the AMG Performance Studio we create cars that are perfectly tailored to your wishes and desires. No limits are placed on our experts’ creativity, who demonstrate their unparalleled craftsmanship and attention to detail in areas as varied as special technical components, extravagant paintwork finishes and the most exclusive interior appointments imaginable, to produce one-off masterpieces.

Enter the world of AMG. Experience true driving performance.

We don't just build cars.  
We make dreams come true.

# Technical data.

	<b>Diesel engines</b>		
	<b>GLC 220 d 4MATIC</b>	<b>GLC 250 d 4MATIC</b>	<b>GLC 350 d 4MATIC</b>
No. of cylinders/arrangement	4/in-line	4/in-line	6/V
Total displacement in cc	2143	2143	2987
Rated output <sup>1</sup> in kW (hp) at rpm	125 (170)/3000-4200	150 (204)/3800	190 (258)/3400
Rated output of electric motor in kW (hp) at rpm	-	-	-
System output in kW (hp) at rpm	-	-	-
Rated torque <sup>1</sup> in Nm at rpm	400/1400-2800	500/1600-1800	620/1600-2400
Rated torque of electric motor in Nm at rpm	-	-	-
Transmission	9G-TRONIC	9G-TRONIC	9G-TRONIC
Acceleration from 0 to 100 km/h in s	8.3	7.6	6.2
Top speed, approx. in km/h	210	222	238
Tyre size – front axle, rear axle	235/65 R 17	235/65 R 17	235/65 R 17
Fuel	Diesel	Diesel	Diesel
Fuel consumption <sup>2</sup> in l/100 km			
Urban/extra-urban/combined	6.3-5.5/5.1-4.7/5.5-5.0	6.3-5.5/5.1-4.7/5.5-5.0	7.2-6.8/5.7-5.3/6.2-5.9
NEDC energy consumption in kWh/100 km <sup>3</sup>	-	-	-
Electric range in km <sup>3</sup>	-	-	-
CO <sub>2</sub> emissions <sup>2</sup> in g/km combined	143-129	143-129	169-159
Emission class <sup>4</sup> /efficiency class <sup>5</sup>	Euro 6/A	Euro 6/A	Euro 6/B
Tank capacity (optional)/of which reserve, approx. in l	50 (66)/7.0	50 (66)/7.0	66/7.0
Boot capacity in l	550-1600	550-1600	550-1600
Turning circle diameter in m	11.80	11.80	11.80
Length <sup>6</sup> /width incl. mirrors <sup>6</sup> in mm	4656/2096	4656/2096	4656/2096
Wheelbase <sup>6</sup> in mm	2873	2873	2873
Track width, front <sup>6</sup> /rear <sup>6</sup> in mm	1621/1617	1621/1617	1621/1617
Kerb weight <sup>7</sup> in kg/perm. GVW in kg	1845/2500	1845/2500	1890/2500
Towing capacity unbraked/braked in kg	750/2500	750/2500	750/2500

**The best for the engine:**  
Genuine Mercedes-Benz engine oils.

<sup>1</sup> Information on rated output and rated torque in accordance with Directive (EC) No. 595/2009 in the currently applicable version. <sup>2</sup> The figures shown for the fuel consumption and the CO<sub>2</sub> emissions were obtained in accordance with the prescribed measuring process (§ 2 nos. 5, 6, 6a Pkw-EnVKV (German Ordinance on Fuel Consumption Labelling) in the currently applicable version). The figures are not based on an individual model and do not constitute part of the product offer; they are provided solely for purposes of comparison between different vehicle models. <sup>3</sup> Figures refer to the electric motor. <sup>4</sup> Data applicable within the European Union only. Country-specific deviations possible. <sup>5</sup> Calculated on the basis of the measured CO<sub>2</sub> emissions taking into account the mass of the vehicle. <sup>6</sup> The dimensions shown are mean

	<b>Petrol engines</b>			<b>Plug-in hybrid</b>
	<b>GLC 250 4MATIC</b>	<b>GLC 300 4MATIC</b>	<b>Mercedes-AMG GLC 43 4MATIC</b>	<b>GLC 350 e 4MATIC</b>
No. of cylinders/arrangement	4/in-line	4/in-line	6/V	4/in-line
Total displacement in cc	1991	1991	2996	1991
Rated output <sup>1</sup> in kW (hp) at rpm	155 (211)/5500	180 (245)/5500	270 (367)/5500-6000	155 (211)/5500
Rated output of electric motor in kW (hp) at rpm	-	-	-	85 (116)/3500
System output in kW (hp) at rpm	-	-	-	235 (320)/5000
Rated torque <sup>1</sup> in Nm at rpm	350/1200-4000	370/1300-4000	520/2500-4500	350/1200-4000
Rated torque of electric motor in Nm at rpm	-	-	-	340/0-2000
Transmission	9G-TRONIC	9G-TRONIC	9G-TRONIC	7G-TRONIC PLUS
Acceleration from 0 to 100 km/h in s	7.3	6.5	4.9	5.9
Top speed, approx. in km/h	222	236	250 <sup>8</sup>	235 <sup>9</sup>
Tyre size – front axle, rear axle	235/65 R 17	235/65 R 17	235/55 R 19, 255/50 R 19	235/60 R 18
Fuel	Premium petrol	Premium petrol	Premium plus grade petrol	Premium petrol
Fuel consumption <sup>2</sup> in l/100 km				
Urban/extra-urban/combined	8.5-8.1/6.3-5.6/7.1-6.5	9.3-8.9/6.7-6.2/7.7-7.2	11.2-10.8/7.3-6.9/8.7-8.3	-/-/2.7-2.5 <sup>10</sup>
NEDC energy consumption in kWh/100 km <sup>3</sup>	-	-	-	15.2-13.9
Electric range in km <sup>3</sup>	-	-	-	34 <sup>10</sup>
CO <sub>2</sub> emissions <sup>2</sup> in g/km combined	166-152	174-163	199-189	64-59
Emission class <sup>4</sup> /efficiency class <sup>5</sup>	Euro 6/B	Euro 6/C	Euro 6/D	Euro 6/A+
Tank capacity, of which reserve, approx. in l	66/7.0	66/7.0	66/7.0	50/7.0
Boot capacity in l	550-1600	550-1600	550-1600	395-1445
Turning circle diameter in m	11.80	11.80	11.80	11.80
Length <sup>6</sup> /width incl. mirrors <sup>6</sup> in mm	4656/2096	4656/2096	4661/2096	4656/2096
Wheelbase <sup>6</sup> in mm	2873	2873	2873	2873
Track width, front <sup>6</sup> /rear <sup>6</sup> in mm	1621/1617	1621/1617	1639/1655	1614/1605
Kerb weight <sup>7</sup> in kg/perm. GVW in kg	1735/2400	1735/2400	1845/2460	2025/2605
Towing capacity unbraked/braked in kg	750/2400	750/2400	750/2460	750/2000

values. They apply to standard-specification, unladen vehicles. <sup>7</sup> Information on kerb weight in accordance with Directive 92/21/EC in the currently applicable version (kerb weight with fuel tank 90% full, driver, 68 kg, and luggage, 7 kg) for standard-specification vehicles. Optional extras and accessories will generally increase this figure and reduce the payload capacity accordingly. <sup>8</sup> Electronically governed. <sup>9</sup> Applies only with fully charged HV battery. <sup>10</sup> During real-life driving, deviations from the certified norm values can occur. The actual values are influenced by a multitude of individual factors, e.g. individual driving style, environmental and route conditions. You can find further technical data at [www.mercedes-benz.com](http://www.mercedes-benz.com)

# Dimensions.

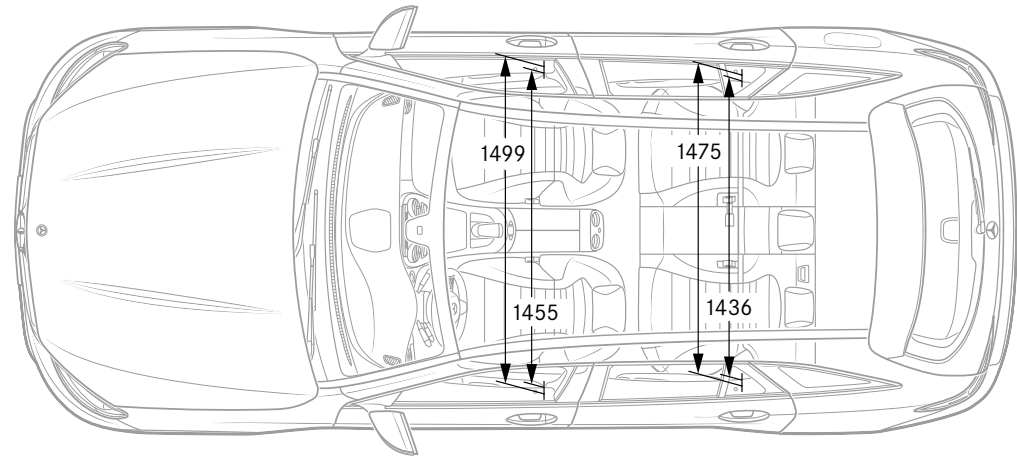
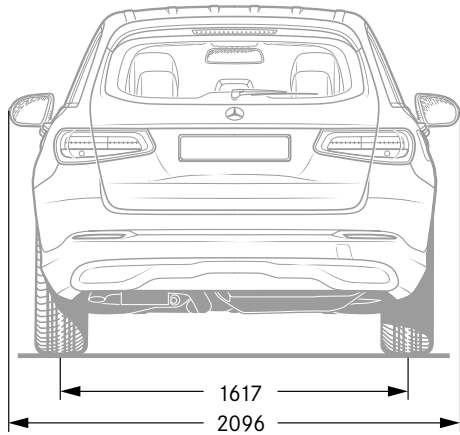
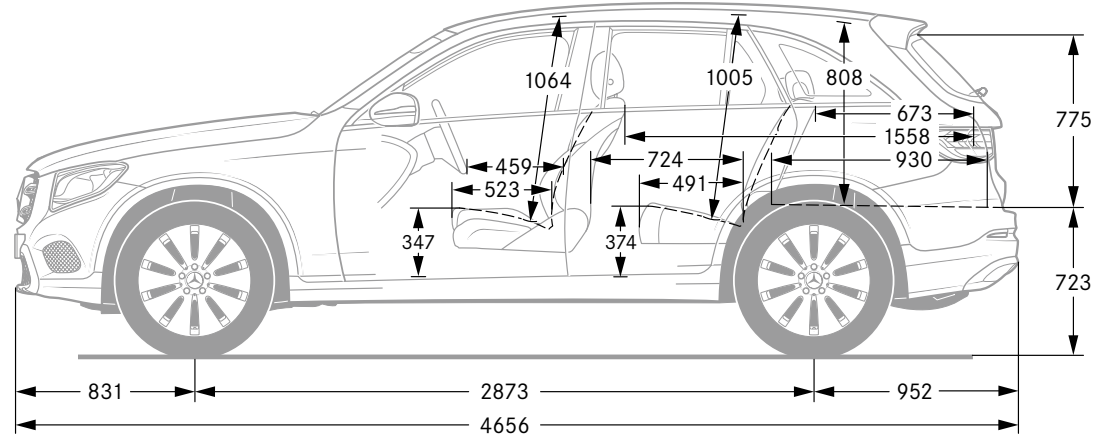
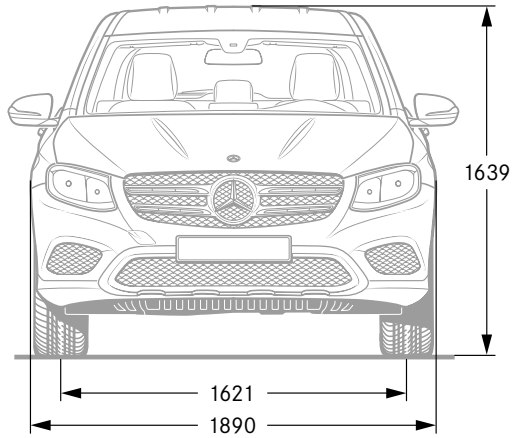

All dimensions in millimetres. The dimensions shown are mean values and apply to standard-specification, unladen vehicles.

# Upholstery and trim.

## Upholstery

- 001 Aberdeen fabric in black
- 101 ARTICO man-made leather in black<sup>1</sup>
- 105 ARTICO man-made leather in silk beige/espresso brown<sup>1</sup>
- 114 ARTICO man-made leather in espresso brown/black<sup>1</sup>
- 115 ARTICO man-made leather in silk beige/black<sup>1</sup>
- 221 Leather in black<sup>1,2</sup>
- 224 Leather in espresso brown/black<sup>1,2</sup>
- 225 Leather in silk beige/espresso brown<sup>1,2</sup>
- 234 Leather in saddle brown/black<sup>1,2</sup>
- 235 Leather in silk beige/black<sup>1</sup>
- 241 Leather in black<sup>2</sup>
- 301 ARTICO man-made leather/Grenoble fabric in black<sup>1,3</sup>
- 314 ARTICO man-made leather/Grenoble fabric in espresso brown/black<sup>1,3</sup>
- 641 ARTICO man-made leather/DINAMICA microfibre in black<sup>4</sup>
- 651 ARTICO man-made leather/DINAMICA microfibre in black<sup>5</sup>
- 971 designo nappa leather in black<sup>1,2</sup>
- 975 designo nappa leather in platinum white pearl/black<sup>1,2</sup>

## Trim

- H80 Piano-lacquer look in black
- H07 Linestructure lime wood in high-gloss brown<sup>1,6</sup>
- 736 Open-pore ash wood in black<sup>1</sup>
- H09 Open-pore ash wood in brown<sup>1</sup>
- 731 Burr walnut wood in high-gloss brown<sup>1</sup>
- H24 Linestructure lime wood in high-gloss light brown<sup>1</sup>
- 739 Piano-lacquer look in black/light-longitudinal grain aluminium<sup>1,4,5</sup>
- H73 AMG trim in carbon fibre/light longitudinal-grain aluminium<sup>1</sup>

<sup>1</sup> Optional extra. <sup>2</sup> Optional extra for Mercedes-AMG GLC 43 4MATIC. <sup>3</sup> Standard for EXCLUSIVE Interior line. <sup>4</sup> Standard for Mercedes-AMG GLC 43 4MATIC. <sup>5</sup> Standard for AMG Interior line. <sup>6</sup> Standard for EXCLUSIVE Interior line and designo black interior.

## Standard equipment



001



101



115

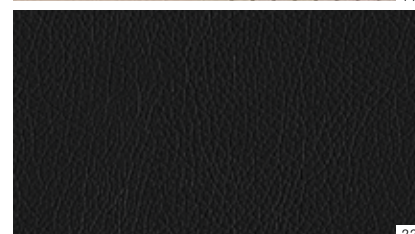

221



235

## EXCLUSIVE Line<sup>1</sup>



301



314



101



105



114

AMG Line<sup>1</sup>

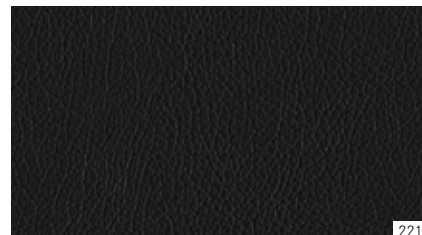
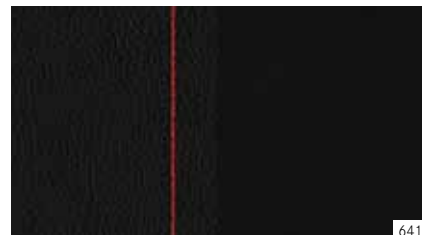
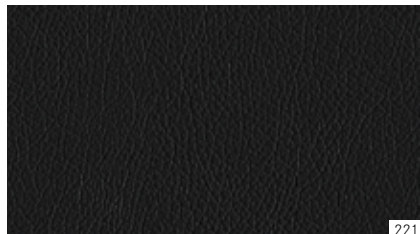

designo<sup>1</sup>



Trim

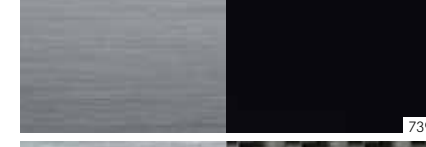
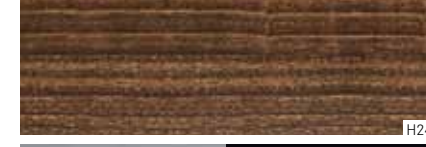
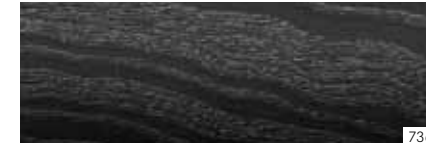
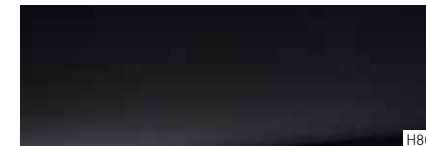

# Paintwork.

## Non-metallic paints



040

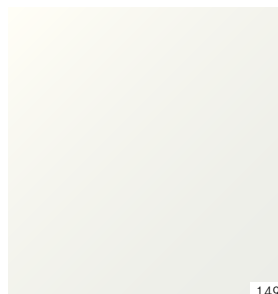

149

## Metallic paints<sup>1</sup>



197



775



896



988



796



992



890

## designo paints<sup>1</sup>



271



799



996

---

### Non-metallic paints

- 040 black  
149 polar white

---

### Metallic paints<sup>1</sup>

- 197 obsidian black  
775 iridium silver  
796 citrine brown  
890 cavansite blue  
896 brilliant blue  
988 diamond silver  
992 selenite grey

---

### designo paints<sup>1</sup>

- 271 designo citrine brown magno  
799 designo diamond white bright  
996 designo hyacinth red metallic
- 

<sup>1</sup> Optional extra.  
Additional individual designo paint finishes are available from your Mercedes-Benz dealer.



**Mercedes-Benz is one of the founding partners of the “Laureus Sport for Good Foundation”.**

Since the foundation was established in 2000, Mercedes-Benz has been supporting and promoting the aims and values of this worldwide non-profit-making programme: to use social sports projects to improve the lives of children and young people who are disadvantaged or suffering from illness. Laureus has become a fundamental element of Mercedes-Benz’s social responsibility. Every new Mercedes is an ambassador embodying these values. In buying a Mercedes you are supporting the “Laureus Sport for Good Foundation”.

**Please note:** changes may have been made to the product since going to print (08.08.2016). The manufacturer reserves the right during the delivery period to make changes to the design, form, colour or specification, provided these changes, while taking into account the interests of the vendor, can be deemed reasonable with respect to the purchaser. Where the vendor or the manufacturer uses symbols or numbers to describe an order or the subject of an order, no rights may be derived solely from these. The illustrations may include accessories and optional extras which do not form part of the standard specification. Actual colours may differ slightly from those shown owing to the limitations of the printing process. This brochure is distributed internationally. Information given regarding statutory regulations, legal requirements and taxation and the consequences thereof applies to the Federal Republic of Germany only and is correct at the time of going to print. For current and more specific information in relation to the range of models, features, optional extras, colours and/or services available in your country, and their pricing, you should contact your nearest authorised Mercedes-Benz Passenger Car Dealer.

[www.mercedes-benz.com](http://www.mercedes-benz.com)

Daimler AG, Mercedesstr. 137, 70327 Stuttgart MS/MAC 6701 · 1631 · 02-02/1216

**Take-back of end-of-life vehicles.** You can return your GLC to us for environment-friendly disposal in accordance with the European Union (EU) End-Of-Life Vehicle Directive. But that day lies a long way off.

A network of vehicle take-back depots and dismantlers is available to make returning your vehicle as easy as possible for you. You are welcome to return your vehicle to one of these establishments free of charge. In so doing, you will be making a valuable contribution towards closing the recycling cycle and preserving resources.

For further information about the recycling and disposal of end-of-life vehicles and take-back conditions, please visit your national Mercedes-Benz website.