



350 SE
350 SEL
450 SE
450 SEL
450 SEL 6.9



Mercedes-Benz – safety means better driving

When Mercedes-Benz introduced the S-class, experts were surprised to discover that with these cars, a very definite forward step had been achieved, despite the existing international reputation for high standards. In their research and development, Mercedes-Benz ventured towards the known limits of physics and technology. Not just to re-design individual components, but to achieve a unique synthesis of driving characteristics, safety and comfort.

Why is this so important?

In highly motorised countries, every car driver is inevitably caught in dense traffic. On the roads of the Federal Republic of Germany alone, there are 18 million cars. As in all other countries, car drivers are confronted with exhortations, appeals and laws, all causing stress, from which the driver must be freed.

Responsible car designers can contribute, through superior engineering, by building vehicles that lighten the driver's workload. The less the pressure on the driver, the more freely traffic can flow and the better we can all live together on the roads.

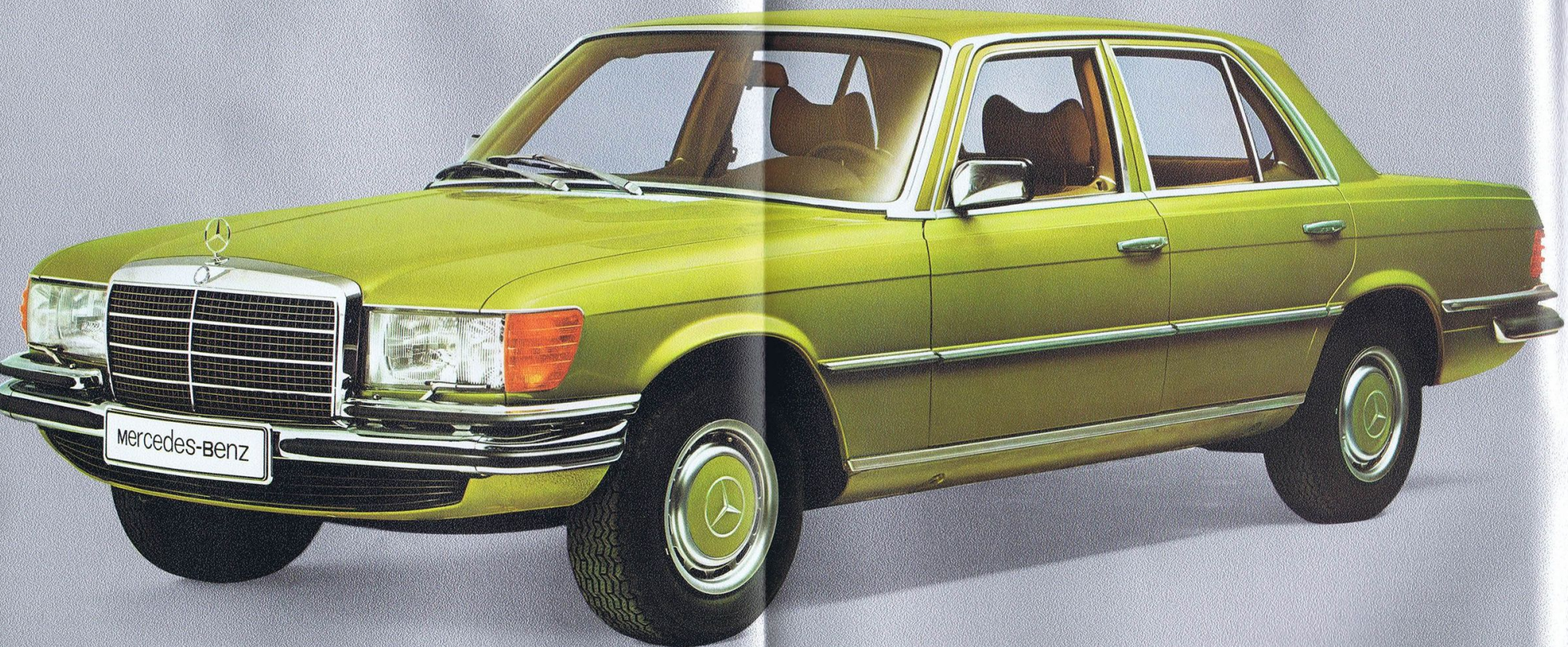

Headlight wipers, outside mirror on the right side and radio with automatic or mechanical aerial are available on request

That is the reason why Mercedes-Benz build cars that are basically different from others.

Mercedes-Benz guarantee you better driving. The tension-reducing-system provided by Mercedes-Benz is totally unique in this synthesis:

1. Mercedes-Benz comfort

Mercedes-Benz cars are built to protect the driver as much as possible from the physical and psychological strains of driving in traffic. Balanced suspension, including the seats, glare-free instruments that can all be read at a glance, the servo-assisted disc brakes – all are components of the system, as are the roomy, comfortable interior and the quietness. This complete physiological safety system has a relaxing effect and minimises the tension that every car driver would gladly do without today.

2. Mercedes-Benz safety

Mercedes-Benz tackled the problem of safety scientifically, earlier than anyone else, and more systematically. It was soon recognised that active or passive safety alone would not do the job, but that both would have to be combined into a complementary system. There is no place in such a system for badly proportioned, functionally designed »tanks« with purely passive safety features, which would, moreover, lead to anti-social behaviour by making the driver feel isolated, and there is certainly no place for very light vehicles constructed with only active safety in mind, for the purpose of gaining the upper hand in traffic. Mercedes-Benz cars are designed for optimum active and passive safety. No other assembly-line produced car in the world can match them when it comes to the combination of both factors. Reassuring for the driver.

3. The quality, reliability and lasting value of a Mercedes-Benz

Sound design, high quality materials and high standards of workmanship, together with the well-known model continuity – no model is changed just for fashion – give you the assurance that you own a car of lasting value. And it is a reassuring feeling to drive a car with legendary reliability. Used car buyers value these qualities and are prepared to pay well for them. Because they know they are a good investment.

4. The international reputation of Mercedes-Benz

The Mercedes-Benz driver-relaxation system has been widely acknowledged:

- Even in such a critical phase of the automobile industry as in 1973/74 with the demand stagnating or receding, Mercedes-Benz showed rising production figures.
- 94% of Mercedes-Benz buyers remain loyal to their brand.
- One of Mercedes-Benz' S-class was named car of the year in 1973.
- The »Frankfurter Allgemeine Zeitung« chose Mercedes-Benz as the best car tested in 1973 and in 1974.
- Those car buyers who cover high mileage or who make frequent business trips decide on Mercedes-Benz for good reasons. The average yearly mileage of all car drivers in the Federal Republic of Germany is 16000 kilometres, but for Mercedes-Benz drivers the figure is 28000. The driver to whom his car is important needs the better automobile – a Mercedes-Benz.

Acquaint yourself in detail with the driver-relaxation system. But keep in mind that this system is much more than the sum of its parts.

Unfortunately, we cannot show you the interplay of the different elements. This is something you must experience for yourself, preferably on a long test

drive. You will discover that Mercedes-Benz cars give you something that has become very important on today's roads, confidence and self-possession.

Generous appointments help you to remain unruffled



Generous appointments help you to remain unruffled

You notice this as soon as you get in the car. The practical one-key system eliminates the annoying search for the right key. No matter which way up you hold the key, it still operates because of its symmetrical shape. Large doors that open very wide and the inset roof make entering and leaving easy and comfortable. Sit down. There is plenty of room. Room for survival. For the passenger compartment that you consider to be so comfortable and roomy has at the same time been designed, calculated and built to act as a safety cell in case of an accident.

Do not forget to fasten your safety belt. The inertia-reel belt allows complete freedom of movement. The belt locks only upon sudden braking. The seat can be adjusted for height and posture. The same goes for the head restraints. When you are seated, take a look around. The 87% all-round field of vision in a Mercedes-Benz affords a commanding view of traffic.

But most important, you feel relaxed and sit uncramped in an anatomically correct posture. You notice that the comfortable, generous interior is not an end in itself, but that it creates an atmosphere of well-being. All controls are well within reach and arranged sensibly and logically. Instruments are centrally grouped, directly in your field of vision. The large-volume boot is easy to load and unload. Every Mercedes-Benz is built to remove as much stress from you as possible.

Mercedes-Benz see comfort as an integral component of physiological safety, that relieves the driver from strain and keeps him alert. It makes you a safe and good-tempered driver. You have fewer problems with traffic, and your fellow drivers have fewer problems with you.



1 Spacious seating and contoured seats with firm lateral support guarantee comfort that keeps you fit while driving. Mercedes-Benz has designed the seats anatomically correct on the basis of objective physical test data.

2 The large-faced outside rear-view mirror gives unobstructed view and can be adjusted from inside when the window is closed. A wide rubber rim keeps it practically free of dirt.

3 Large doors that open wide make getting in and out easy. An important safety factor are the wide kneeguards beneath the dashboard.

4 The back seat with folding centre armrest has a total width of more than one-and-one-half metres. Inertia reel safety belts can be installed in the rear as an optional extra.

5 The illuminated, easy-to-load boot has a capacity of some 520 litres. Even large amounts of holiday luggage present no problem.

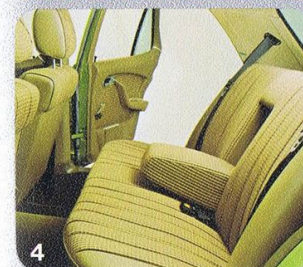

Safety
eliminates
uncertainty



In the Black Forest near Baden-Baden, Federal Republic of Germany

Safety eliminates uncertainty

Mercedes-Benz' safety research started long before public discussion of safety problems. It began thirty years ago, not by force of law, but out of a sense of responsibility. Today there is no other standard production vehicle in the world that combines more active and passive safety features yet still impresses so much with its harmony and timeless elegance.

Active safety. That means among other things road safety, for example the track-holding ability of the running gear with its diagonal swing axle, individual wheel suspension, and wide track. The zero offset steering of the front wheels that no longer allows unequal forces to affect steering negatively under hard braking. Firm vibration damping without loss of road "feel". Or the tight-gripping servo-assisted disc brakes. The standard power-assisted steering that, together with the directionally-stable suspension, allow for fast evasive action. And not to be forgotten are the high-performance eight cylinder engines, among the most modern power plants in the world. They guarantee that you can take advantage of opportunities without endangering others. Active safety means that all measures have been taken to help to avoid accidents, driving safety, operational and physiological safety and perceptual safety.

We would like to describe in a few words how conscientiously Mercedes-Benz have systematised perceptual safety, an aspect often neglected by others. The 87% field of vision gives a better overall view of traffic. Special mouldings on the windscreen pillars deflect water and help to keep the side windows clean. The large exterior mirror, adjustable from within the car, provides good rear vision. A rain runnel keeps the back window clean. Large rear lights (that remain mostly free from dirt) with clear, high-intensity signals and a special surface contour, are not only an advantage for the Mercedes-Benz driver. They are also vital for the one driving behind. Headlights with large reflectors provide optimum road illumination. This system of perceptual safety (to see and be seen) makes it easy for you to act reasonably and responsibly.

However, active safety must be complemented by extensive interior and exterior passive safety measures. In case an accident cannot be avoided. Passive safety means eliminating or lessening the effects of an accident. This is accomplished by a large number of various, exactly coordinated measures. Take for example the passenger safety cell. It complements the deformable, energy absorbing front and rear ends (crumple zones). Doors with burst proof locks. All interior parts that may be dangerous to the passenger in the event of an accident are either padded, rounded off, recessed or deformable. The high lateral strength of the body and the crush-resistant design of the roof have been exactly calculated.

These are only two examples from more than a hundred elements that together compose a perfect system of active and passive safety.

A Mercedes-Benz driver can feel this safety and be confident in the knowledge that it can be counted on in an emergency. This safety eliminates uncertainty. In this respect Mercedes-Benz safety is much more than just a contribution to your well-being. It is also a benefit for other drivers.

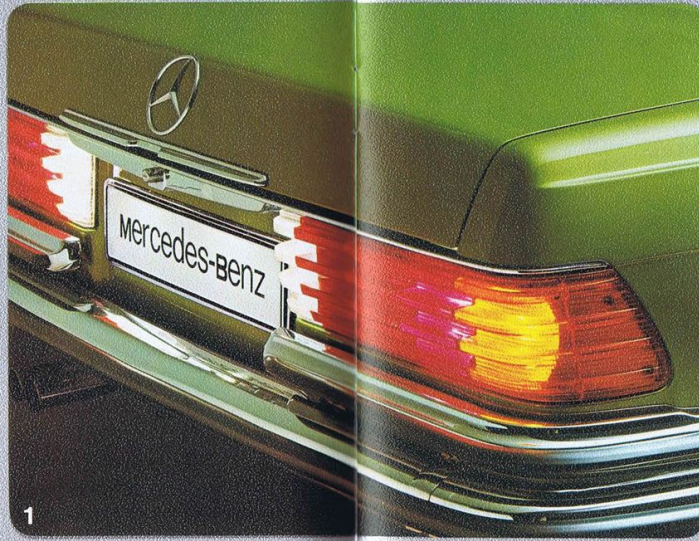

1

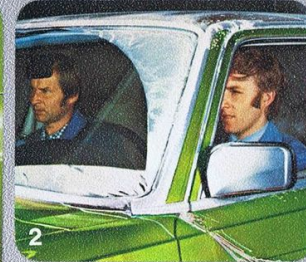

2

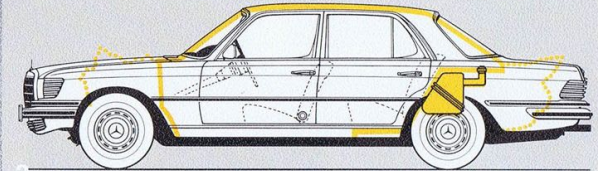

1 The large tail lights give intense, distinct signals. The special shape of their surface keeps them largely clean.

2 The side windows stay clean because water is deflected by mouldings on the windscreen pillars.

3 The safety-cell principle of design was conceived by Mercedes-Benz in 1951. The rigid compartment protects the passengers. Front and rear ends (crumple zones) are deformable in a precalculated pattern.

4 The horizontally arranged halogen headlights received the highest ratings in tests and comparisons. (Headlight wipers optional extra.)

5 Diagram of Mercedes-Benz' safety steering. Top: original position. Bottom: possible deformation.

6 Accurate wheel-location is ensured by the semitrailing arms of the diagonal swing axle. Spring deflection on one wheel does not affect the other which continues to follow a straight line.



4

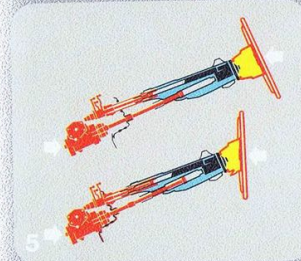

5

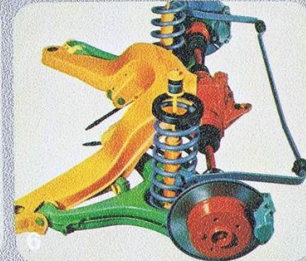

6

Relaxation
reduces stress

Corniche de l'Esterel on the Côte d'Azur, France



Relaxation reduces stress

Some cars make it difficult for their drivers to be civil. Their designers may have solved the problem of getting up to 180 as fast as possible, but not the problem of how to remain fresh after a six hour trip at 130 kmph.

Top speed alone has never been an objective at Mercedes-Benz. Our goal is always the perfect synthesis of driving performance, safety and comfort. Only relaxed drivers can play a positive rôle in traffic.

Mercedes-Benz drivers value the performance of their cars because it is no end in itself, but pre-requisite for taking advantage of opportunities in traffic. On the other hand it enables you to make concessions to other drivers. You do not have to continually prove your superiority to yourself and to others.

In the S-class graduated engine outputs are available, according to the driver's wishes. In-line six cylinder twin overhead camshaft or V8 engines. It is not the number of horsepower that is important, but the way in which power is employed. It is difficult to describe how this power is converted into driving performance, it is something you must experience. This is also true of the easy, sure control of the vehicle, the space, the operational and seating comfort. The compact overall size which is easy to handle and the small turning circle, combined with the precise, smooth, power-assisted steering take the problem out of quick driving and evasive manoeuvres.

In a Mercedes-Benz, hectic driving is not infectious. Everything possible has been done to keep you alert yet relaxed, because this encourages a cooperative attitude. An important contribution by Mercedes-Benz to safe and sane driving.



1 High speed alone has never been an engineering goal at Mercedes-Benz. The goal is solely the perfect synthesis of driving performance, safety and comfort.

2 The round, glare-free instruments are grouped together centrally at the upper edge of the safety dashboard and can be read at a glance. The impact absorber, capable of transforming impact energy into controlled deformation, is located beneath the large padded boss in the centre of the safety steering wheel.

3 Low centre of gravity, wide track, ideal axle design (diagonal swing axle, front axle with zero-offset steering) and anti-roll bars all contribute to the unexcelled driving comfort.

4 The V8 engine with fuel injection and transistorized ignition. The engine's strength is in the medium engine speed range, guaranteeing the best adjustment possible to all traffic conditions.

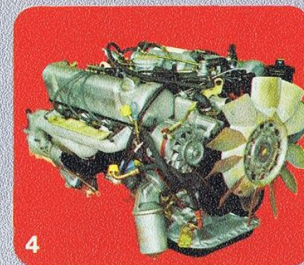

Dependability
creates
satisfaction



Dependability creates satisfaction

W

hat good is the most beautiful car, if you have nothing but trouble with it? Breakdowns caused by poor engineering and workmanship? Breakdowns that not only cause you but also your fellow drivers trouble. Stranded vehicles can cause hold-ups.

Mercedes-Benz drivers can be confident that their cars will do their duty reliably and without problems. For the overriding objective in design and construction at Mercedes-Benz is a mature car. Co-ordinated in its overall conception, able to satisfy the highest demands in engineering and workmanship.

It is Mercedes-Benz' policy to produce roadworthy, safe and functional cars. Fashion and extravagance are irrelevant. For decades we have followed this proven path, no rapid model changes, no model change just for the sake of it. The criterion for change is solely genuine engineering progress.

Thinking in terms of quality comes naturally not only in development work, but also in the choice of material and in production and workmanship.

Mercedes-Benz have established their reputation on this quality. This is the only area in which we consider ourselves bound by tradition. For that reason, for every 10 skilled workers engaged in production there is one in quality control. These specialists reject everything that is not 100 percent up to quality standards. Only such strict controls at all stages of production guarantee the standard of quality for which Mercedes-Benz have always been known.

Mercedes-Benz cars are serviced and cared for with the same thoroughness and exactness with which they are built. It was not without good reason that Mercedes-Benz were able to extend maintenance intervals to 15,000 kilometres. That saves time and money.

The best guarantee for the operational safety of your Mercedes-Benz are the 41,500 maintenance experts who are always kept informed of the latest technical advances, 1,000 service stations in the Federal Republic of Germany, another 1,000 in Europe, and a total of 4,300 service stations in 165 countries. In addition, in the summer vacation months, mobile service units operate on main tourist routes.

This gives Mercedes-Benz drivers confidence. A driver who reacts coolly and confidently and a technically faultless car together make a perfect team - more and more a necessity on today's roads.

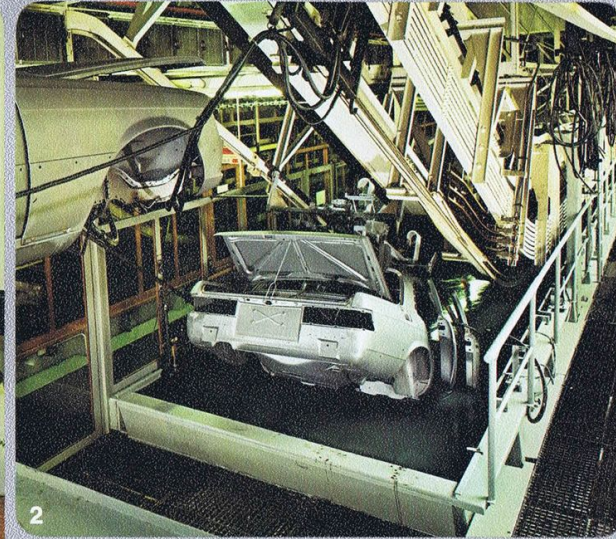

1 41,500 service experts, constantly briefed and trained to keep pace with the latest engineering advancements, more than 1,000 workshops in the Federal Republic, another 1,000 in Europe, a total of 4,300 service stations in 165 countries - this is one of the best guarantees for the operational safety of your Mercedes-Benz.

by stones at critical points, second primer, protective coating for the sides and the lower part of the front, basic coating, special top coat, protection of hollow parts with special wax, anti-corrosive wax for all parts installed later.

2 A complex system of protective measures to preserve the value of your Mercedes-Benz: cavity conservation with zinc paint, phosphating and passivation, first primer, coating to prevent damage

3 Where the human eye and ear no longer suffice, modern electronic control, measuring and testing devices are employed.

4 Important bolts are checked by hand afterwards. The paint mark means "OK".



On the preceding pages we showed you why Mercedes-Benz cars are built as they are and how they differ in product philosophy from others.

Everything has been done to make driving easier. No other car manufacturer makes greater efforts than Mercedes-Benz.

The illustrations in this catalogue show cars in use in various countries. Therefore they do not necessarily correspond in all details to the standard equipment for your country.

Please ask your dealer to tell you about the standard specification in your country.

350 SE/SEL

The power potential of the V8 engine is fascinating, its 200 HP/DIN (147 kW) allowing a maximum speed of 205 kmph and an acceleration from 0 to 100 kmph in 9.5 seconds. More important than these figures, however, is the ability to cope with every traffic situation, safely and effortlessly. Both cars are unexcelled in this. The 350 SEL is 10 centimetres longer than the 350 SE. That means a larger interior, i. e. more room in the back. The rear doors are also larger and make getting in and out even easier.



350 SE/SEL

Basic Equipment

Engine

V8 engine with fuel injection and transistorized ignition, 200 DIN/hp at 5,800 rpm, 147 kW at 5,800/min.

Transmission/Clutch

Fully synchronized four-speed gearbox with floor shift, self-adjusting diaphragm spring clutch. Optional extra: automatic 3-speed transmission with torque converter.

Axles

Front axle with double wishbones and anti-dive control.

Zero offset steering, axle with brake torque compensation. Self-levelling device as an optional extra.

Brakes

Dual-circuit power braking system, disc brakes on all four wheels, internally ventilated at the front, turbo blades for additional cooling on all four rims. Parking brake with additional brake shoes and brake drums; brake-failure warning light for both circuits.

Suspension

On both front and rear axles, two coil springs and one anti-roll bar. Two double-action, hydraulic, telescopic shock absorbers front and rear.

Steering

Accurate power-assisted steering; steering damper, large padded steering wheel boss, impact absorber under the padded boss, telescopically collapsible steering column. Steering box located well behind the front axle.

Bodywork

Frame-floor unit firmly welded to the body. Rigid, torsion-resistant passenger compartment (safety cell), energy absorbing front and rear sections, fuel tank located over the rear axle, maximum all-round vision, panoramic safety glass windows.

Four easy-closing doors, rubber strip inserts in decorative mouldings on both sides, bumpers with broad rubber inserts.

Seats

Anatomically contoured seats shaped to give lateral support, seat springing adjusted to vehicle suspension and seating position. Front seats firmly anchored, adjustable forwards and backwards, backrest also adjustable, driver's seat adjustable for height, fully-reclining front seats. Head rests and automatic safety belts on the front seats.

Heating and ventilation

Continuous warm or cold air flow, draught-free, with additional blower for windscreen, side windows and front and rear footwells; air volume and air distribution for warm and cold air infinitely and independently variable, heating separately controlled for right and left sides; large fresh air inlet in the middle of the instrument panel, infinitely variable adjustment to right and left; front doors integrated into the heating and ventilation system. Continuous air venting.

Windscreen

Laminated safety glass; screen washer foot-operated with wiper contact; two-speed windscreen wipers, also intermittent control, operated by the combination switch on the steering column.

Signalling system

Headlamp flasher; self-cancelling indicators with fingertip contact for overtaking, operated by the combination switch on the steering column; high-frequency horn; brake lights; hazard warning system.

Lighting system

Parking lights, asymmetric halogen low-beams, halogen high-beam headlights, halogen foglamps; side lights, reversing lights; rear foglight; infinitely variable instrument illumination; luggage compartment light; interior lights with door contacts and hand switch; rear roof light, illuminated ashtray, glove box and heater controls.

Instruments

Instrument panel padded, yields under impact; speedometer; oil pressure gauge, fuel gauge; water temperature gauge; indicator lights for parking brake, battery, indicators, high-beam and fuel reserve; crystal-controlled clock; mileage recorder; daily mileage recorder. Rev counter as an optional extra.

Locks

Safety locks on all doors; childproof locks on the rear doors; luggage compartment lock; steering wheel lock combined with ignition lock, starter and starter non-repeat unit; master key for the doors, ignition lock, luggage compartment, fuel tank and glove box; second key for doors, ignition lock and fuel tank only.

Miscellaneous

Oddments tray between the front seats; pockets on the front doors; rear parcel shelf; rear-view mirror, adjustable to anti-glare position; padded sun visors with vanity mirror on passenger side; grab handles; padded armrests with grab handles on the doors; centre armrest between rear seats; cigar lighter; ashtrays front and rear; anchorage points for safety belts at the rear; carpet throughout; towing lugs front and rear, warning triangle.

The contents of this brochure are not binding, and the right is reserved to make modifications without notice.

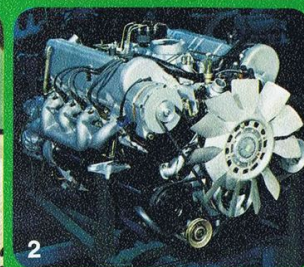

1 The 350 SEL has a 10 cm longer wheelbase, and a greater interior and overall length than the 350 SE. The passengers in the back seat get the full benefit of these 10 cm. That means more leg room, more freedom of movement. The back doors are accordingly larger and make getting in and out even easier.

2 3.5 l V8 engine with fuel injection and transistorized ignition. This engine guarantees effortless acceleration in all speed ranges and thus the ability to cope easily with any traffic situation.

3 Wide, padded impact areas on the roof pillars and frame, and doors fully lined with impact-damping padding provide optimal interior safety.



350 SE/SEL

Technical Data

Number of cylinders	8	
Bore/Stroke	92/65.8 mm	3.62/2.59 ins.
Total displacement	3,499 cc 213.6 cu. ins.	
Engine output acc. to DIN 1)	200 DIN/hp at 5,800 rpm 147 kW at 5,800 min	
Max. torque acc. to DIN 1)	29.2 mkp at 4,000 rpm 286 Nm at 4,000 min	
Compression ratio	9.5	
Engine oil capacity max./min.	7.5/5.5 litres	13.2/9.7 Imp. pts.
Capacity of cooling system	13.5 litres 23.8 Imp. pts.	
Generator	14 V/55 A	
Battery	12 V/66 Ah	

Max. speed	205 kmph approx. 127 mph approx.	
Tyres	205/70 HR 14	
Fuel	premium	
Fuel consumption acc. to DIN 70030 2)	13.0 litres 100 km	22 miles per Imp. gal.
Tank capacity incl. reserve	96 litres 13 litres approx.	21.1 Imp. gals. 2.9 Imp. gals.
Weights	350 SE	350 SEL
Kerb weight 3)	1,675 kg	1,700 kg
Perm. gross weight	2,195 kg	2,220 kg
Trailer load with brake 4)	1,200 kg	1,200 kg
Trailer load without brake 4)	750 kg	750 kg

	350 SE		350 SEL	
A Overall height, unladen	1,425 mm	56.1 ins.	1,430 mm	56.3 ins.
B Overall width	1,870 mm	73.6 ins.	1,870 mm	73.6 ins.
C Overall length	4,960 mm	195.3 ins.	5,060 mm	199.2 ins.
D Wheelbase	2,865 mm	112.8 ins.	2,965 mm	116.7 ins.
E Steering wheel - driver's seat backrest 5)	400 mm	15.7 ins.	400 mm	15.7 ins.
F Seat height, unladen, front	970 mm	38.2 ins.	970 mm	38.2 ins.
G Driver's backrest - rear seat backrest 5)	772 mm	30.3 ins.	872 mm	34.3 ins.
H Seat height at rear	860 mm	33.9 ins.	860 mm	33.9 ins.
J Overall seat width, front	1,460 mm	57.5 ins.	1,460 mm	57.5 ins.
K Width at shoulder height, front	1,403 mm	55.2 ins.	1,403 mm	55.2 ins.
L Overall seat width, rear	1,528 mm	60.2 ins.	1,528 mm	60.2 ins.
M Width at shoulder height, rear	1,385 mm	54.5 ins.	1,385 mm	54.5 ins.
Track width, front	1,525 mm	60.0 ins.	1,525 mm	60.0 ins.
Track width, rear	1,505 mm	59.2 ins.	1,505 mm	59.2 ins.
Turning circle diameter	11.44 m	37.53 ft.	11.78 m	38.6 ft.
Boot space	approx. 0.52 m ³	approx. 17.8 cu. ft.	approx. 0.52 m ³	approx. 17.8 cu. ft.

5) Dimensions vary according to seating position.

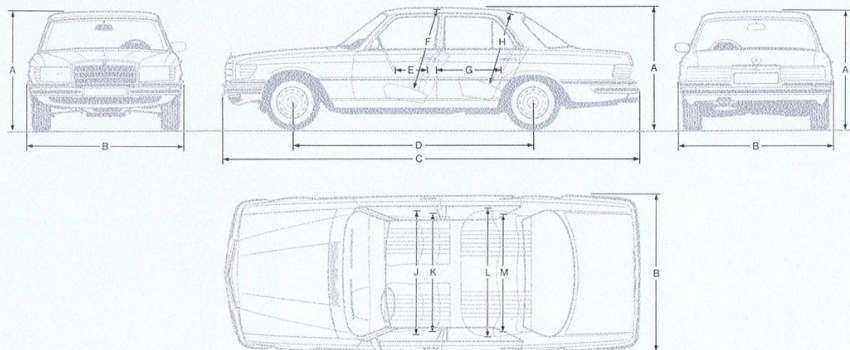

1) The output given in DIN/hp, or kW is effectively available at the clutch for driving the vehicle, any other power consumption has already been deducted. The data given in SI units (kW = kilowatt, Nm = Newton metre) has been converted and rounded off to the nearest unit.

2) Technical data according to DIN 70020 and 70030. Fuel consumption according to DIN 70030. This value is obtained at a constant speed of 90 km/h, max. 110 km/h (68 mph) on an even road, plus 10%. This method is used by all automobile manufacturers in the Federal Republic of Germany.

The consumption values quoted are, therefore, calculated under the same conditions and provide a basis for comparison. They do not correspond, however, to the actual amount of fuel consumed, as this varies according to the style of driving, road and climatic conditions etc. Fuel consumption according to DIN 70030 is therefore only a comparative value and not the actual amount of fuel consumed.

3) The figure for kerb weight applies to standard version vehicles. Special equipment increases this figure.

4) The weights quoted are maximum weights, valid within the Federal Republic of Germany. In other countries different figures may apply.

The contents of this brochure are not binding and the right is reserved to make modifications without notice.

450 SE

The 450 SE differs from the 350 SE in engine output, transmission and running gear. The 4.5 litre V8 engine gives 225 HP/DIN (165 kW) and reaches highest performance and torque at an appreciably lower r. p. m. Starting torque compensation on the rear axle makes up for the increased torque. Dipping at the rear during acceleration is completely eliminated. A 3-speed automatic transmission with torque converter is standard equipment in the 450 SE.

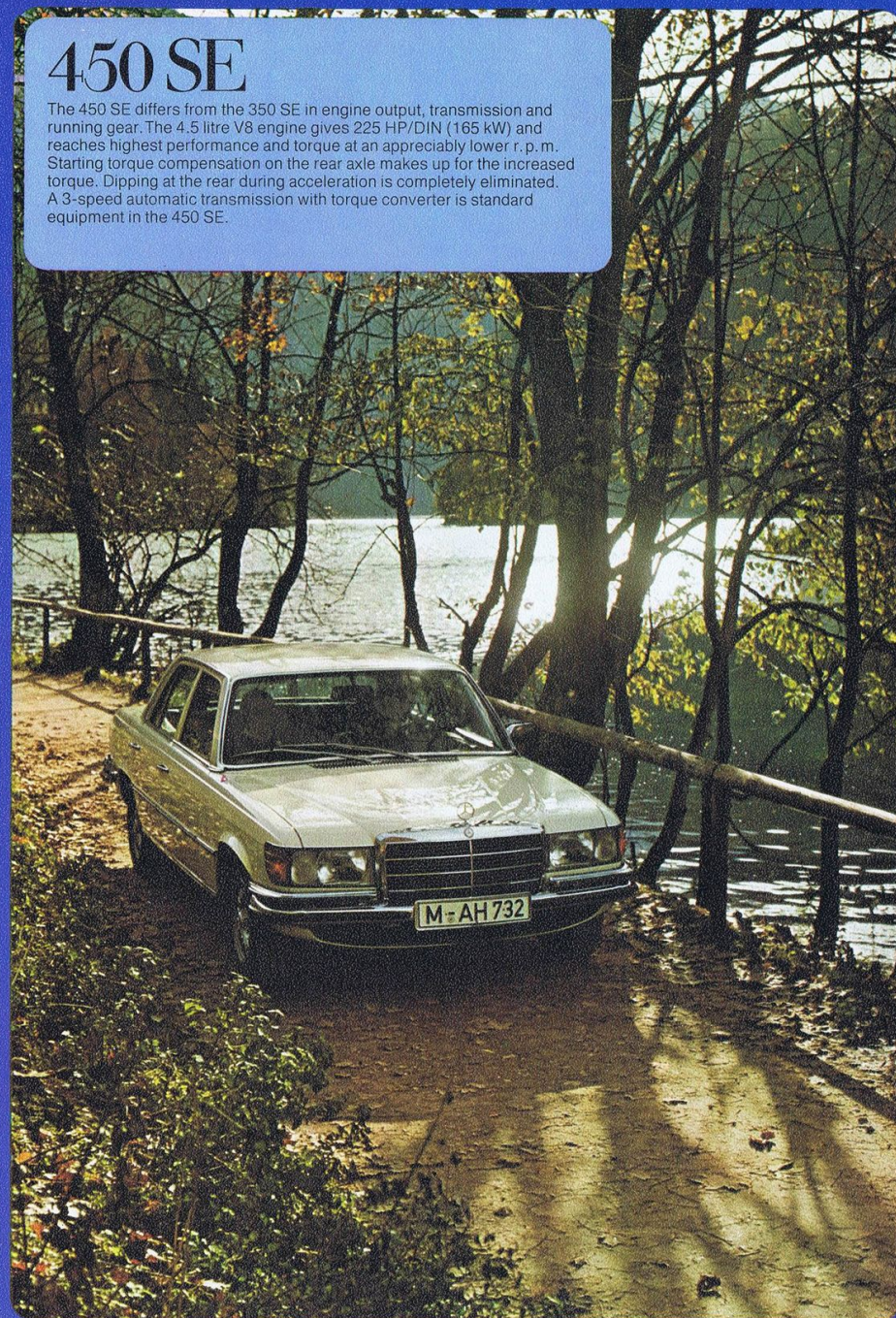

450 SE Basic Equipment

Engine

V8 engine with fuel injection and transistorized ignition
225 DIN/hp at 5,000 rpm,
165 kW at 5,000/min.

Transmission

Automatic 3-speed transmission with torque converter.

Axles

Front axle with double wishbones and anti-dive control.
Zero offset steering.

Rear axle: diagonal swing axle with brake and starting torque compensation.

Brakes

Dual-circuit power braking system, disc brakes on all four wheels, internally ventilated at the front, turbo blades for additional cooling on all four rims. Parking brake with additional brake shoes and brake drums; brake-failure warning light for both circuits.

Suspension

On both front and rear axles, two coil springs and one anti-roll bar. Two double-action, hydraulic, telescopic shock absorbers front and rear. Self-levelling device as an optional extra.

Steering

Accurate power-assisted steering; steering damper, large padded steering wheel boss, impact absorber under the padded boss, telescopically collapsible steering column. Steering box located well behind the front axle.

Bodywork

Frame-floor unit firmly welded to the body. Rigid, torsion-resistant passenger compartment (safety cell), energy absorbing front and rear sections, fuel tank located over the rear axle, maximum all-round vision, panoramic safety glass windows.

Four easy-closing doors, rubber strip inserts in decorative mouldings on both sides, bumpers with broad rubber inserts.

Seats

Anatomically contoured seats shaped to give lateral support, seat springing adjusted to vehicle suspension and seating position. Front seats firmly anchored, adjustable forwards and backwards, backrest also adjustable, driver's seat adjustable for height, fully-reclining front seats. Head rests and automatic safety belts on the front seats.

Heating and ventilation

Continuous warm or cold air flow, draught-free, with additional blower for windscreen, side windows and front and rear footwells; air volume and air distribution for warm and cold air infinitely and independently variable, heating separately controlled for right and left sides; large fresh air inlet in the middle of the instrument panel, infinitely variable adjustment to right and left; front doors integrated into the heating and ventilation system. Continuous air venting.

Windscreen

Laminated safety glass; screen washer foot-operated with wiper contact; two-speed windscreen wipers, also intermittent control, operated by the combination switch on the steering column.

Signalling system

Headlamp flasher; self-cancelling indicators with fingertip contact for overtaking, operated by the combination switch on the steering column; high-frequency horn; brake lights; hazard warning system.

Lighting system

Parking lights, asymmetric halogen low-beams, halogen high-beam headlights, halogen foglamps; side lights, reversing lights; rear foglight; infinitely variable instrument illumination; luggage compartment light; interior lights with door contacts and hand switch; rear roof light, illuminated ashtray, glove box and heater controls.

Instruments

Instrument panel padded, yields under impact; speedometer; oil pressure gauge, fuel gauge; water temperature gauge; indicator lights for parking brake, battery, indicators, high-beam and fuel reserve; crystal-controlled clock; mileage recorder; daily mileage recorder. Rev counter as an optional extra.

Locks

Safety locks on all doors; childproof locks on the rear doors; luggage compartment lock; steering wheel lock combined with ignition lock, starter and starter non-repeat unit; master key for the doors, ignition lock, luggage compartment, fuel tank and glove box; second key for doors, ignition lock and fuel tank only.

Miscellaneous

Oddments tray between the front seats; pockets on the front doors; rear parcel shelf; rear-view mirror, adjustable to antiglare position; padded sun visors with vanity mirror on passenger side; grab handles; padded armrests with grab handles on the doors; centre armrest between rear seats; cigar lighter; ashtrays front and rear; anchorage points for safety belts at the rear; carpet throughout; towing lugs front and rear, warning triangle.

The contents of this brochure are not binding, and the right is reserved to make modifications without notice.



1 The heating and ventilation systems - a system of draught-free cold and warm air circulation - can be individually operated by means of a lever in the centre console and regulated separately for driver and co-driver. A total of eleven adjustable air inlets. (The radio installed here is available as an optional extra.)

2 Standard equipment on the 450 SE is the 3-speed automatic transmission with torque converter. (Electric window winders are an optional extra.)

3 Each of the front seats can be adjusted forward and backward. The backrest is also adjustable for rake. In addition the driver's seat can be also vertically adjusted.

4 The dual-circuit power brake system includes disc brakes on all wheels. The front brake discs are ventilated internally.

5 An anti-squat device is incorporated in the rear axle to accommodate the high engine output. Dipping of the rear end during acceleration is completely eliminated. In addition, the rear end is held down when braking.

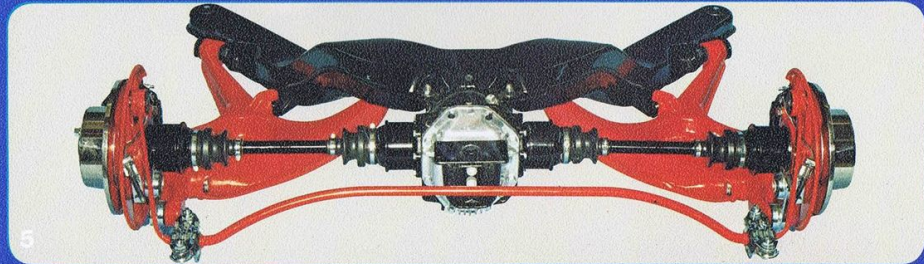

450 SE

Technical Data

Number of cylinders	8	
Bore/Stroke	92/85 mm	3.62/3.35 ins.
Total displacement	4,520 cc	275.8 cu. ins.
Engine output acc. to DIN ¹⁾	225 DIN/hp at 5,000 rpm 165 kW at 5,000 min	
Max. torque acc. to DIN ¹⁾	38.5 mkg at 3,000 rpm 378 Nm at 3,000 min	
Compression ratio	8.8	
Engine oil capacity max./min.	7.5/5.5 litres	13.2/9.7 Imp. pts.
Capacity of cooling system	15 litres	26.4 Imp. pts.
Generator	14 V/55 A	
Battery	12 V/66 Ah	
Max. speed	210 kmph approx. 131 mph approx.	
Tyres	205/70 VR 14	
Fuel	premium	
Fuel consumption acc. to DIN 70 030 ²⁾	14.5 litres/ 100 km	20 miles per Imp. gal.
Tank capacity	96 litres	21.1 Imp. gals.
Incl. reserve	13 litres approx.	2.9 Imp. gals.
Weights		
Kerb weight ³⁾	1,730 kg	
Perm. gross weight	2,250 kg	
Trailer load with brake ⁴⁾	1,200 kg	
Trailer load without brake ⁴⁾	750 kg	

A Overall height, unladen	1,425 mm	56.1 ins.
B Overall width	1,870 mm	73.6 ins.
C Overall length	4,960 mm	195.3 ins.
D Wheelbase	2,860 mm	112.6 ins.
E Steering wheel - driver's seat backrest ⁵⁾	400 mm	15.7 ins.
F Seat height, unladen, front	970 mm	38.2 ins.
G Driver's backrest - rear seat backrest ⁵⁾	772 mm	30.3 ins.
H Seat height at rear	860 mm	33.9 ins.
J Overall seat width, front	1,460 mm	57.5 ins.
K Width at shoulder height, front	1,403 mm	55.2 ins.
L Overall seat width, rear	1,528 mm	60.2 ins.
M Width at shoulder height, rear	1,385 mm	54.5 ins.
Track width, front	1,525 mm	60.0 ins.
Track width, rear	1,505 mm	59.2 ins.
Turning circle diameter	11.44 m	37.53 ft.
Boot space	approx. 0.52 m ³	approx. 17.8 cu. ft.

⁵⁾ Dimensions vary according to seating position.

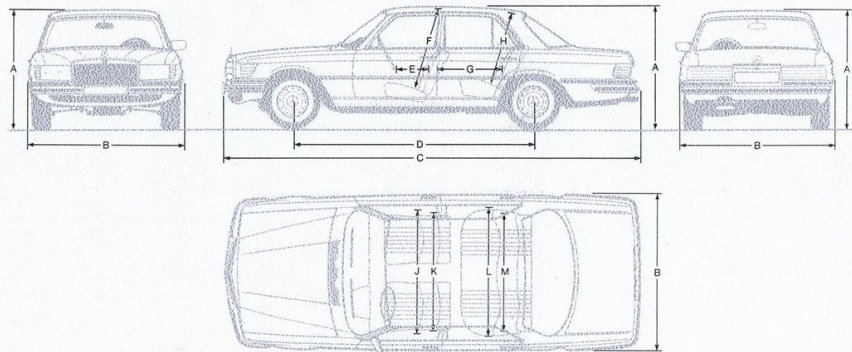

¹⁾ The output given in DIN/hp, or kW is effectively available at the clutch for driving the vehicle, any other power consumption has already been deducted. The data given in SI units (kW = kilowatt, Nm = Newton metre) has been converted and rounded off to the nearest unit.

²⁾ Technical data according to DIN 70 020 and 70 030. Fuel consumption according to DIN 70 030. This value is obtained at a consistent speed of 7/8 of maximum, max. 110 kph, (68 mph) on an even road, plus 10%. This method is used by all automobile manufacturers in the Federal Republic of Germany.

The consumption values quoted are, therefore, calculated under the same conditions and provide a basis for comparison. They do not correspond, however, to the actual amount of fuel consumed, as this varies according to the style of driving, road and climatic conditions etc. Fuel consumption according to DIN 70 030 is therefore only a comparative value and not the actual amount of fuel consumed.

³⁾ The figure for kerb weight applies to standard version vehicles. Special equipment increases this figure.

⁴⁾ The weights quoted are maximum weights, valid within the Federal Republic of Germany. In other countries different figures may apply.

The contents of this brochure are not binding and the right is reserved to make modifications without notice.

450 SEL

Technically equipped like the 450 SE (4.5 litre V8 engine, starting-torque compensation, 3-speed automatic transmission with torque converter), but much more spacious (10 centimetres additional space in the back, larger rear doors) and with more comfortable interior appointments. Electrically-operated windows, central locking system, velours upholstery and carpeting, parcel nets on the back of the front seats, delay switch for the front interior lights, contact switch on the rear doors for the rear roof light.



450 SEL

Basic Equipment

Engine

V8 engine with fuel injection and transistorized ignition. 225 DIN/hp at 5,000 rpm, 165 kW at 5,000/min.

Transmission

Automatic 3-speed transmission with torque converter.

Axles

Front axle with double wish-bones and anti-dive control. Zero offset steering. Rear axle diagonal swing axle with brake and starting torque compensation.

Brakes

Dual-circuit power braking system, disc brakes on all four wheels, internally ventilated at the front, turbo blades for additional cooling on all four rims. Parking brake with additional brake shoes and brake drums; brake-failure warning light for both circuits.

Suspension

On both front and rear axles, two coil springs and one anti-roll bar. Two double-action, hydraulic, telescopic shock absorbers front and rear. Self-levelling device as an optional extra.

Steering

Accurate power-assisted steering; steering damper, large padded steering wheel boss, impact absorber under the padded boss, telescopically collapsible steering column. Steering box located well behind the front axle.

Bodywork

Frame-floor unit firmly welded to the body. Rigid, torsion-resistant passenger compartment (safety cell), energy absorbing front and rear sections, fuel tank located over the rear axle, maximum all-round vision, panoramic safety glass windows. Electric window winders. Four easy-closing doors, rubber strip inserts in decorative mouldings on both sides, bumpers with broad rubber inserts.

Seats

Anatomically contoured seats shaped to give lateral support, seat springing adjusted to vehicle suspension and seating position. Front seats firmly anchored, adjustable forwards and backwards, backrest also adjustable, driver's seat adjustable for height, fully-reclining front seats. Head rests and automatic safety belts on the front seats. Velours upholstery and parcel nets on the back of the front seats.

Heating and ventilation

Continuous warm or cold air flow, draught-free, with additional blower for wind-screen, side windows and front and rear footwells; air volume and air distribution for warm and cold air infinitely and independently variable, heating separately controlled for right and left sides; large fresh air inlet in the middle of the instrument panel, infinitely variable adjustment to right and left; front doors integrated into the heating and ventilation system. Continuous air venting.

Windscreen

Laminated safety glass; screen washer foot-operated with wiper contact; two-speed wipers, also intermittent control, operated by the combination switch on the steering column.

Signalling system

Headlamp flasher; self-cancelling indicators with fingertip contact for overtaking, operated by the combination switch on the steering column; high-frequency horn; brake lights; hazard warning system.

Lighting system

Parking lights, asymmetric halogen low-beams, halogen high-beam headlights, halogen foglamps; side lights, reversing lights; rear foglight; infinitely variable instrument illumination; luggage compartment light; interior lights with door contacts and hand switch; delay switch for the front interior lights; contact switch on the rear doors for the rear roof light, illuminated ashtray, glove box and heater controls.

Instruments

Instrument panel padded, yields under impact; speedometer; oil pressure gauge, fuel gauge; water temperature gauge; indicator lights for parking brake, battery, indicators, high-beam and fuel reserve; crystal-controlled clock; mileage recorder; daily mileage recorder. Rev counter as an optional extra.

Locks

Safety locks on all doors; childproof locks on the rear doors; luggage compartment lock; steering wheel lock combined with ignition lock, starter and starter non-repeat unit; master key for the doors, ignition lock, luggage compartment, fuel tank and glove box; second key for doors, ignition lock and fuel tank only. Vacuum-controlled master lock system.

Miscellaneous

Oddments tray between the front seats; pockets on the front doors; rear parcel shelf; rear-view mirror, adjustable to anti-glare position; padded sun visors with vanity mirror on passenger side; grab handles; padded armrests with grab handles on the doors; centre armrest between rear seats; cigar lighter; ashtrays front and rear; anchorage points for safety belts at the rear; velours carpet throughout; towing lugs front and rear, warning triangle.

The contents of this brochure are not binding, and the right is reserved to make modifications without notice.



1 Besides having a roomier interior the 450 SEL differs from the 450 SE mainly as to appointments: Electric window winders with individual controls in the centre console, velours upholstery and carpeting are all standard equipment. (Seat heating for the front seats with separate controls beside the selector lever for the automatic transmission is available as an optional extra.)

2 The front seats recline and are adjustable forwards and backwards. Backrests are also adjustable for rake. The driver's seat can be also vertically adjusted.

3 Standard fittings are the parcel nets on the back of the front seats.

4 The 450 SEL is as spacious as the 350 SEL. That means a longer wheelbase, greater overall length and even more room than in the 350 SE/450 SE models. 10 cm more. The increase benefits the back-seat passengers. The back doors are also larger and make getting in and out even easier.



450 SEL

Technical Data

Number of cylinders	8	
Bore/Stroke	92/85 mm	3.62/3.35 ins.
Total displacement	4,520 cc 275.8 cu. ins.	
Engine output acc. to DIN ¹⁾	225 DIN/hp at 5,000 rpm 165 kW at 5,000 min	
Max. torque acc. to DIN ¹⁾	38.5 mkp at 3,000 rpm 378 Nm at 3,000 min	
Compression ratio	8.8	
Engine oil capacity max./min.	7.5/5.5 litres	13.2/9.7 Imp. pts.
Capacity of cooling system	15 litres	26.4 Imp. pts.
Generator	14 V/55 A	
Battery	12 V/66 Ah	
Max. speed	210 kmph approx. 131 mph approx.	
Tyres	205/70 VR 14	
Fuel	premium	
Fuel consumption acc. to DIN 70030 ²⁾	14.5 litres/ 100 km	20 miles per Imp. gal.
Tank capacity incl. reserve	96 litres 13 litres approx.	21.1 Imp. gals. 2.9 Imp. gals.
Weights		
Kerb weight ³⁾	1,765 kg	
Perm. gross weight	2,285 kg	
Trailer load with brake ⁴⁾	1,200 kg	
Trailer load without brake ⁴⁾	750 kg	

A Overall height, unladen	1,430 mm	56.3 ins.
B Overall width	1,870 mm	73.6 ins.
C Overall length	5,060 mm	199.2 ins.
D Wheelbase	2,960 mm	116.5 ins.
E Steering wheel - driver's seat backrest ⁵⁾	400 mm	15.7 ins.
F Seat height, unladen, front	970 mm	38.2 ins.
G Driver's backrest - rear seat backrest ⁵⁾	872 mm	34.3 ins.
H Seat height at rear	860 mm	33.9 ins.
J Overall seat width, front	1,460 mm	57.5 ins.
K Width at shoulder height, front	1,403 mm	55.2 ins.
L Overall seat width, rear	1,528 mm	60.2 ins.
M Width at shoulder height, rear	1,385 mm	54.5 ins.
Track width, front	1,525 mm	60.0 ins.
Track width, rear	1,505 mm	59.2 ins.
Turning circle diameter	11.78 m	38.6 ft.
Boot space	approx. 0.52 m ³	approx. 17.8 cu. ft.

⁵⁾ Dimensions vary according to seating position.

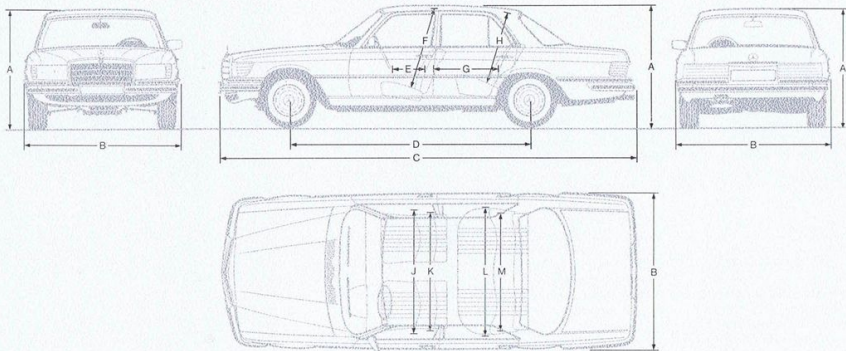

¹⁾ The output given in DIN/hp, or kW is effectively available at the clutch for driving the vehicle, any other power consumption has already been deducted. The data given in SI units (kW = kilowatt, Nm = Newton metre) has been converted and rounded off to the nearest unit.

²⁾ Technical data according to DIN 70 020 and 70 030. Fuel consumption according to DIN 70 030. This value is obtained at a consistent speed of 90% of maximum, max. 110 kph, (68 mph) on an even road, plus 10%. This method is used by all automobile manufacturers in the Federal Republic of Germany.

The consumption values quoted are, therefore, calculated under the same conditions and provide a basis for comparison. They do not correspond, however, to the actual amount of fuel consumed, as this varies according to the style of driving, road and climatic conditions etc. Fuel consumption according to DIN 70 030 is therefore only a comparative value and not the actual amount of fuel consumed.

³⁾ The figure for kerb weight applies to standard version vehicles. Special equipment increases this figure.

⁴⁾ The weights quoted are maximum weights, valid within the Federal Republic of Germany. In other countries different figures may apply.

The contents of this brochure are not binding and the right is reserved to make modifications without notice.

450 SEL 6.9

The top model in the S-class with unequalled driving comfort and spaciousness. An extremely smooth running, quiet 6.9 litre V8 engine (286 HP/DIN, 210 kW), with hydraulic valve clearance compensation, dry sump lubrication, transistorized ignition, fuel injection, 3-speed automatic transmission with torque converter, starting torque compensation, limited slip differential, hydropneumatic suspension, air conditioning, central locking system, electrically-operated windows, headlamp wipers, front seats adjustable for height, heated rear window, safety belts and head restraints in the back seat as well.



450 SEL 6.9 Basic Equipment

Engine

V8 engine with fuel injection and transistorized ignition. 286 HP/DIN at 4,250 rpm; 210 kW at 4,250/min.

Tempomat

Automatically holds a speed that can be individually programmed.

Transmission

Automatic 3-speed transmission with torque converter.

Axles

Front axle with double wishbones and anti-dive control. Zero offset steering. Rear axle diagonal swing axle with brake and starting torque compensation. Limited slip differential.

Brakes

Dual-circuit power braking system, disc brakes on all four wheels, internally ventilated at the front, turbo blades for additional cooling on all four rims. Parking brake with additional brake shoes and brake drums; brake-failure warning light for both circuits. Brake lining wear indicator.

Suspension

Hydropneumatic suspension with self-levelling device on front and rear axles.

Steering

Accurate power-assisted steering; steering damper, large padded steering wheel boss, impact absorber under the padded boss, telescopically collapsible steering column. Steering box located well behind the front axle.

Bodywork

Frame-floor unit firmly welded to the body. Rigid, torsion-resistant passenger compartment (safety cell), energyabsorbing front and rear sections, fuel tank located over the rear axle, maximum all-round vision, panoramic safety glass windows.

Electric window openers. Four easy-closing doors, rubber strip inserts in decorative mouldings on both sides, bumpers with broad rubber inserts.

Seats

Anatomically contoured seats shaped to give lateral support, seat springing adjusted to vehicle suspension and seating position. Front seats firmly anchored, adjustable forwards and backwards and in height backrest also adjustable, fully-reclining front seats. Fold-back armrest between the front seats. Head rests and automatic safety belts on the front and rear seats. Velours upholstery and parcel nets on the back of the front seats.

Air conditioning and heat absorbing glass

Windscreen

Laminated safety glass; screen washer foot-operated with wiper contact; two-speed windscreen wipers, also intermittent control, operated by the combination switch on the steering column. Heated rear window.

Signalling system

Headlamp flasher; self-cancelling indicators with fingertip contact for overtaking, operated by the combination switch on the steering column; high-frequency horn; brake lights; hazard warning system. Headlamp washer unit.

Lighting system

Parking lights, asymmetric halogen low-beams, halogen high-beam headlights, halogen foglamps; side lights, reversing lights; rear foglight; infinitely variable instrument illumination; luggage compartment light; interior lights with door contacts and hand switch; a delay switch for the front interior lights and a contact switch on the rear doors for the rear roof light, illuminated ashtray, glove box and heater controls.

Instruments

Instrument panel padded, yields under impact; speedometer; rev counter; oil pressure gauge, fuel gauge; water temperature gauge; indicator lights for parking brake, battery indicators, high-beam and fuel reserve; crystal-controlled clock; mileage recorder; daily mileage recorder.

Locks

Safety locks on all doors; childproof locks on the rear doors; luggage compartment lock; steering wheel lock combined with ignition lock, starter and starter non-repeat unit; master key for the doors, ignition lock, luggage compartment, fuel tank and glove box; second key for doors, ignition lock and fuel tank only. Vacuum-controlled master lock system.

Miscellaneous

Oddments tray between the front seats; pockets on the front doors; rear parcel shelf; rear-view mirror, adjustable to antiglare position; padded sun visors with vanity mirror on passenger side; grab handles; padded armrests with grab handles on the doors; centre armrest between rear seats; cigar lighter; ashtrays front and rear; anchorage points for safety belts at the rear; velours carpet throughout; towing lugs front and rear, warning triangle.

The contents of this brochure are not binding, and the right is reserved to make modifications without notice.

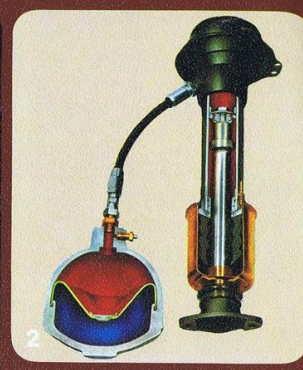
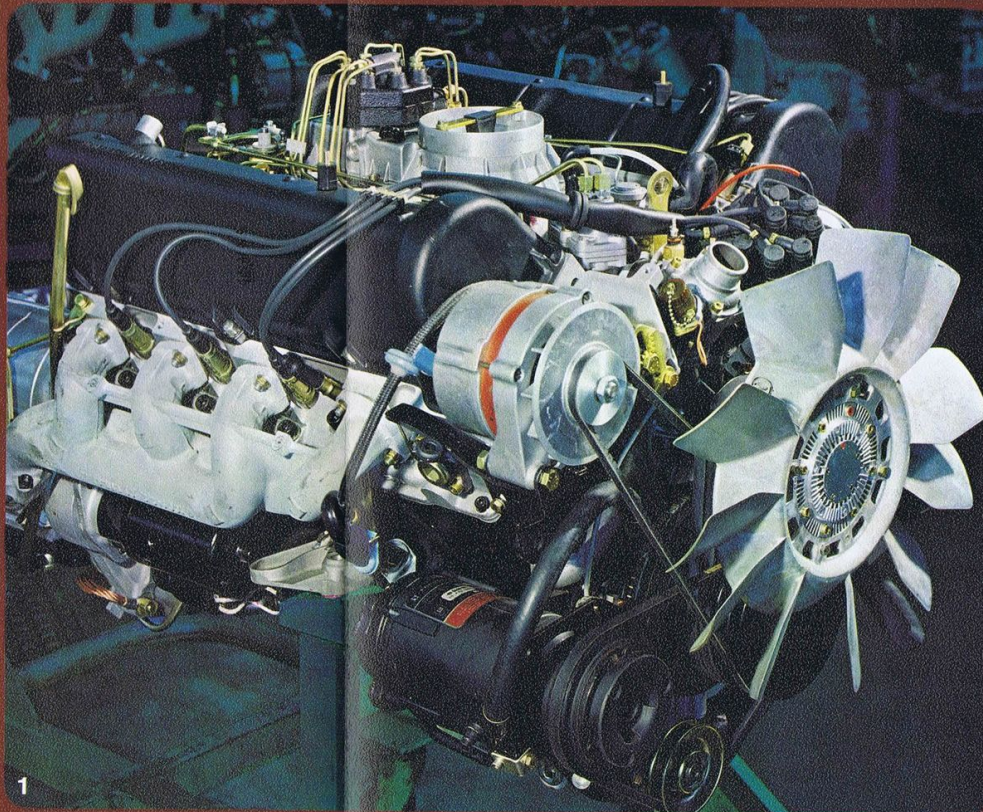

- 1 The 6.9 l V8 engine with hydraulic valve clearance compensation, dry-sump lubrication, fuel injection and transistorized ignition is extremely smooth and quiet running.
- 2 Sectional view of a gas-filled spring actuator and a spring strut of the hydropneumatic suspension. The weight of the vehicle is borne by four of these units that function as shock absorbers at the same time. Moreover the car can be raised 40 mm if a larger ground clearance is needed.
- 3 A crystal-controlled clock is incorporated in the standard rev counter.
- 4 The standard Tempomat cruise control with separate switch on the steering wheel automatically holds a speed that can be programmed individually.
- 5 Air conditioning and heat-absorbing glass are also standard equipment.



450 SEL 6.9 Technical Data

Number of cylinders	8	
Bore/stroke	107/95 mm	4.21/3.74 ins.
Total displacement	6,834 cc	417.1 cu. ins.
Engine output acc. to DIN ¹⁾	286 DIN/hp at 4,250 rpm 210 kW at 4,250 min	
Max. torque acc. to DIN ¹⁾	56 mkp at 3,000 rpm 550 Nm at 3,000 min	
Compression ratio	8.8	
Dry-sump oil tank capacity max./min.	12/10 litres	21.1/17.6 imp. pts.
Capacity of cooling system	16 litres	28.2 imp. pts.
Generator	14 V/75 A	
Battery	12 V/88 Ah	
Top speed	225 kmph approx. 140 mph approx.	
Tyres	215/70 VR 14	
Fuel	premium	
Fuel consumption acc. to DIN 70 030 ²⁾	16 litres/100 km	17 miles per imp. gal.
Tank capacity incl. reserve	96 litres	21.1 imp. gals.
Weights		
Kerb weight ³⁾	1,935 kg	
Perm. gross weight	2,420 kg	
Trailer load with brake ⁴⁾	1,200 kg	
Trailer load without brake ⁴⁾	750 kg	

A Overall height, unladen	1,430 mm	56.3 ins.
B Overall width	1,870 mm	73.6 ins.
C Overall length	5,060 mm	199.2 ins.
D Wheelbase	2,960 mm	116.5 ins.
E Steering wheel - driver's seat backrest ⁵⁾	400 mm	15.7 ins.
F Seat height, unladen, front	970 mm	38.2 ins.
G Driver's backrest - rear seat backrest ⁵⁾	872 mm	34.3 ins.
H Seat height at rear	860 mm	33.9 ins.
J Overall seat width, front	1,460 mm	57.5 ins.
K Width at shoulder height, front	1,403 mm	55.2 ins.
L Overall seat width, rear	1,528 mm	60.2 ins.
M Width at shoulder height, rear	1,385 mm	54.5 ins.
Track width, front	1,525 mm	60.0 ins.
Track width, rear	1,505 mm	59.2 ins.
Turning circle diameter	11.78 m	38.6 ft.
Boot space	approx. 0.52 m ³	approx. 17.8 cu. ft.

⁵⁾ Dimensions vary according to seating position.

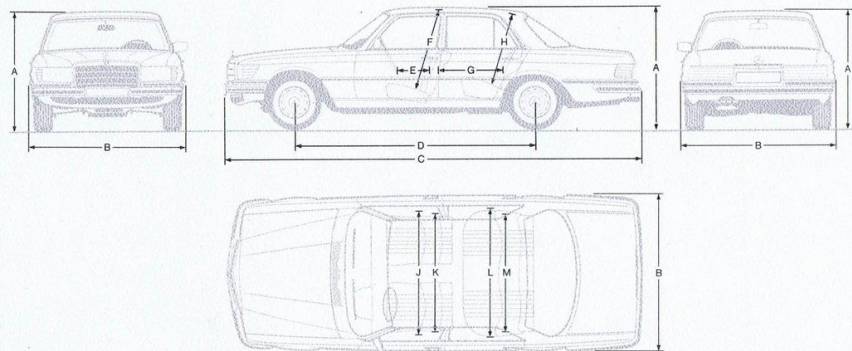

¹⁾ The output given in DIN/hp, or kW is effectively available at the clutch for driving the vehicle, any other power consumption has already been deducted. The data given in SI units (kW = kilowatt, Nm = Newton metre) has been converted and rounded off to the nearest unit.

²⁾ Technical data according to DIN 70 020 and 70 030. Fuel consumption according to DIN 70 030. This value is obtained at a consistent speed of 3/4 of maximum, max. 110 kph (68 mph) on an even road, plus 10%. This method is used by all automobile manufacturers in the Federal Republic of Germany.

The consumption values quoted are, therefore, calculated under the same conditions and provide a basis for comparison.

They do not correspond, however, to the actual amount of fuel consumed, as this varies according to the style of driving, road and climatic conditions etc. Fuel consumption according to DIN 70 030 is therefore only a comparative value and not the actual amount of fuel consumed.

³⁾ The figure for kerb weight applies to standard version vehicles. Special equipment increases this figure.

⁴⁾ The weights quoted are maximum weights, valid within the Federal Republic of Germany. In other countries different figures may apply.

The contents of this brochure are not binding and the rights is reserved to make modifications without notice.

Optional Extras

If you want to personalize your Mercedes-Benz in order to give it an individual atmosphere, many extras are available. Here are just a few examples. For further details see our catalogue "Mercedes-Benz Special Equipment".

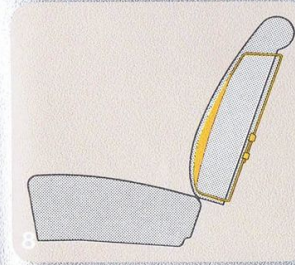
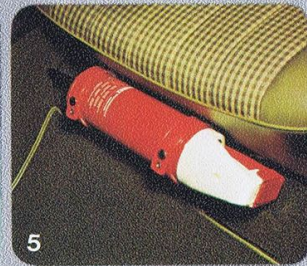
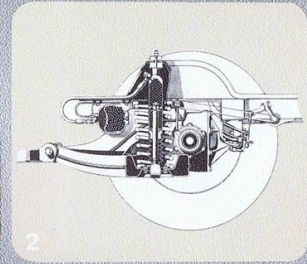

1 Head restraints and inertia-reel safety belts for back seats*

2 Self-levelling device*

3 Central locking system**

4 Light-alloy rims

5 Fire extinguisher

6 Heated seats

7 Operating switch for seat-heater in the centre console

8 Orthopaedic seats

9 You can choose the colour of your car from a chart showing the comprehensive range of standard and special paintwork. For each model, the upholstery range offers a wide choice of colours to complement the paintwork of your car.

* standard in the 450 SEL 6.9 models
** standard in the 450 SEL and 450 SEL 6.9 models

This catalogue describes the basic equipments laid down for the Federal Republic of Germany. In various other countries the basic equipments can vary, due partly to different legal requirements. We therefore request our customers to obtain information from their Mercedes-Benz distributors as to the equipments actually available.

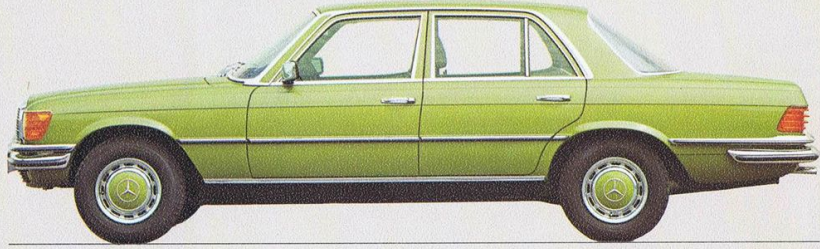

Daimler-Benz AG, Stuttgart-Ulm-Karlsruhe - WZ 463 120 52 0375 - Hersteller: Federal Republic of Germany - Importeur: Repolhaus AG, 47119 Krefeld

Mercedes-Benz

