

PAJERO SPORT



www.new-pajerosport.com

MITSUBISHI
MOTORS
Drive@earth

The Destination Is Up to You

Whether your life is at the heart of the city or off the beaten path, Pajero Sport is built to bring you to the best of both worlds. It's a sleek new look that blends together more than three decades of Mitsubishi 4x4 design experience with sophisticated styling and smooth performance. Active and dynamic, Pajero Sport is always ready to move you.



2.5-liter DI-D High-Power / Titanium Gray Metallic [U17]
Equipment may vary according to market.



Command Your Environment

From up here, the world simply looks easier. Step into the driver's seat, and Pajero Sport awaits your decision. Ergonomically-designed controls and a luxuriously upholstered, fully-adjustable seat create a driving environment that feels tailored to your needs. The interior is wide and spacious, with plenty of legroom for the 2nd and 3rd rows, so your passengers will enjoy the journey almost as much as you do.



2.5-liter DI-D High-Power 7-seater / Black / beige interior with beige leather seats
Equipment may vary according to market.



2.5-liter DI-D High-Power 5-seater / Black / gray interior with gray leather seats
Equipment may vary according to market.

Note: 3.2-liter model meter cluster shown below.
Actual red zone may differ according to models.



Engine and Drivetrain



2.5-liter DI-D High-Power / Titanium Gray Metallic [U17]
Equipment may vary according to market.

DI-D COMMONRAIL

The Common Rail fuel system delivers a precise, steady fuel supply to each cylinder, enabling maximum output with minimum waste for better efficiency and emission reduction. The computer-controlled feedback system allows for continual adjustment, ensuring peak performance at all times.



Intercooler

The intercooler allows more air to be pumped to the cylinders, for more complete combustion and greater power. Positioned at the front of the radiator, this design gives Pajero Sport improved air-cooling performance.

16-valve layout

This arrangement creates a more complete air/fuel mixture and steadier flow for constant high performance. The precisely balanced roller rocker arms and scissor gears provide exact valve timing for more powerful combustion.

Turbocharger

The turbo system adds an impressive boost to air intake pressure, producing more power from each cylinder stroke.

3.2-liter 16-valve Intercooled Turbocharged DOHC Common Rail DI-D (4M41)

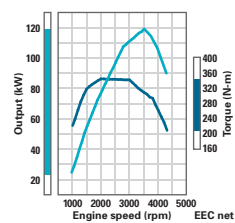

Max output
120kW (163PS) / 3,500rpm
Max torque
343N-m (35.0kg-m) / 2,000rpm

2.5-liter 16-valve Intercooled Turbocharged DOHC Common Rail DI-D (4D56)

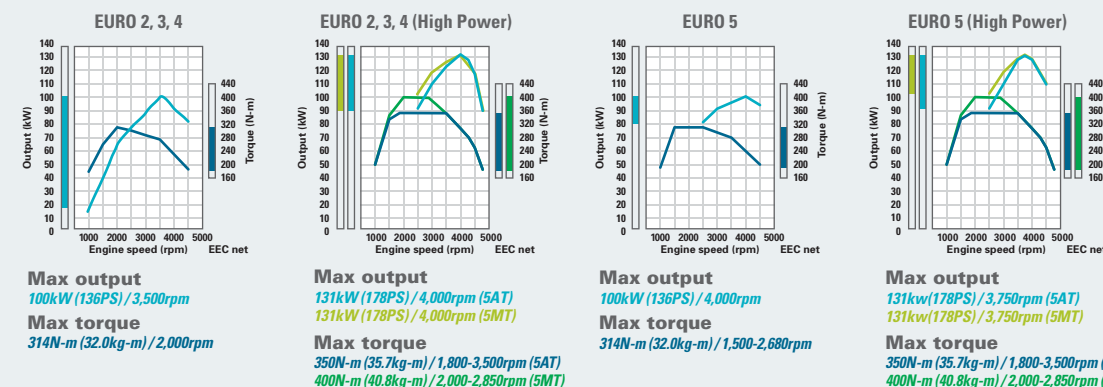

Note: Please refer to P19 for 3.5-liter ECI-MULTI and 3.0-liter MIVEC engines.

SUPER SELECT 4WD

Mitsubishi's rally-proven Super Select 4WD lets you move from smooth 2H mode highway performance to rugged 4H mode traction without breaking stride. With shift-on-the-fly convenience at up to 100km/h, the right driving mode is always at your fingertips.

2H
(2WD high range)

4H
(4WD high range)

4HLc
(4WD high range with locked center differential)

4LLc
(4WD low range with locked center differential)

EASY SELECT 4WD

Mitsubishi's rally-proven Easy Select 4WD lets you move from smooth 2WD highway performance to rugged 4WD off-road traction without breaking stride. With shift-on-the-fly convenience at up to 100km/h, the right driving mode is always at your fingertips.

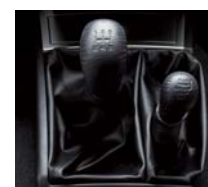

5-speed MT

The 5-speed manual transmission is available for those who prefer the feel of control that only a stick shift can give. The smooth lever movement and intuitive placement make shifting easy and confident.



INVECS-II AT with Sports Mode

For drivers who prefer the convenience of an automatic, INVECS-II 4-speed and 5-speed automatic transmissions provide smooth, intelligent shifting. INVECS-II shift control analyzes driving conditions to select the best shifting style, and can even study driving preferences to create a profile that matches driver characteristics. Sports Mode gives drivers direct command over shifting with all the control of a manual transmission and the convenience of an automatic.

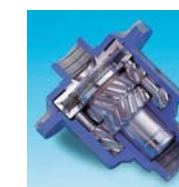

Hybrid LSD

The hybrid-type Limited-Slip Differential (LSD) gives excellent off-road response, combining the torque-sensing benefit of helical gears and a speed-sensing of a viscous coupling unit, all designed to work together with ABS.

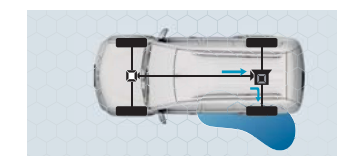

Without LSD

The LSD uses an internal clutch escape mechanism to prevent torque loss if one wheel starts spinning.

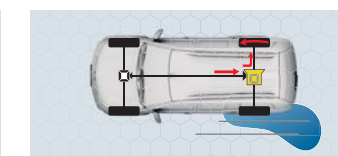

With LSD

Driving Ability



2.5-liter DI-D High-Power / Titanium Gray Metallic [U17]
Equipment may vary according to market.

4WD traction

A double-wishbone front suspension with coil springs combined with a 3-link coil spring rear suspension, both with stabilizer bars, give unmatched traction and stability with a high ground clearance for going off-road.

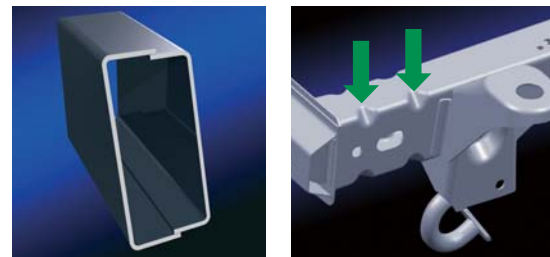
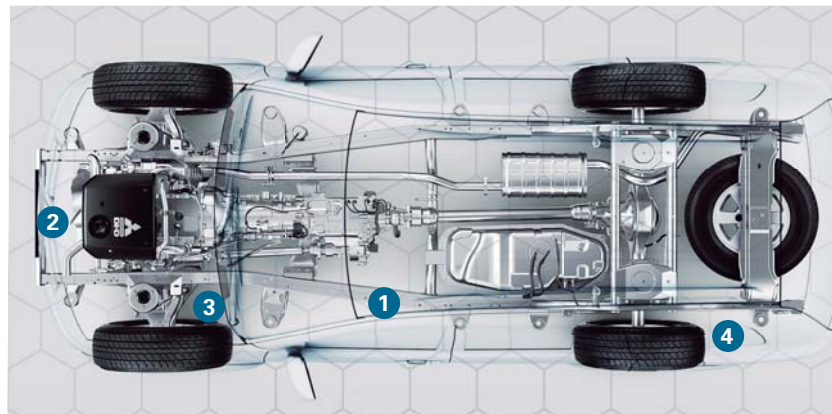

- 1 Tougher, lighter frame beams**
Pajero Sport uses beams made from thinner, lighter steel that provides all the strength of thicker beams, with less weight.
- 2 Impact-absorbing collapsible beads**
Built within the frame, they help absorb collision energy before it can reach the cabin interior, providing added protection to occupants.

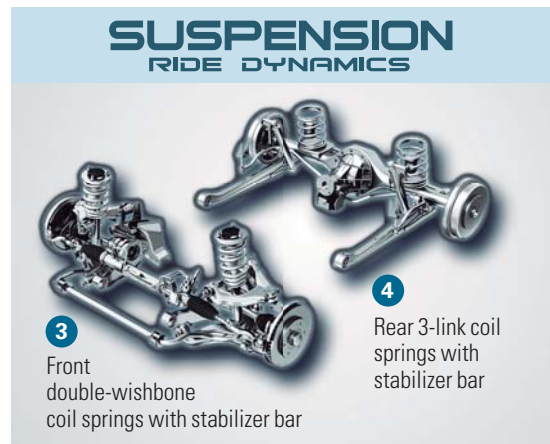

- SUSPENSION RIDE DYNAMICS**
- 3** Front double-wishbone coil springs with stabilizer bar
 - 4** Rear 3-link coil springs with stabilizer bar

Superior terrain handling ability

Some measure performance in seconds, some in millimeters. Mitsubishi measures it in obstacles overcome and goals reached. Because challenges come in all shapes and sizes, Pajero Sport is designed to climb up, over, around and through the toughest terrain that nature can provide.

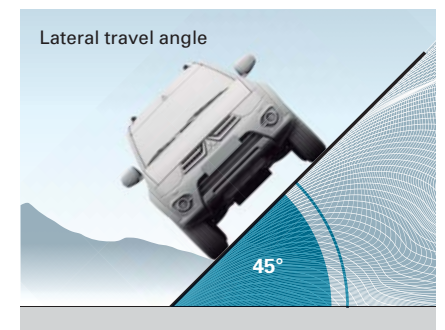
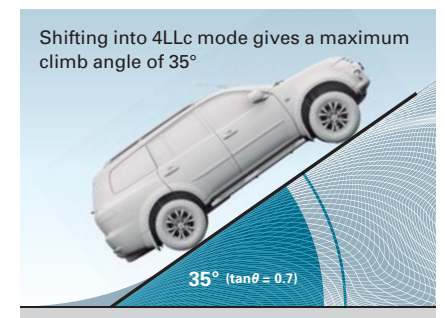
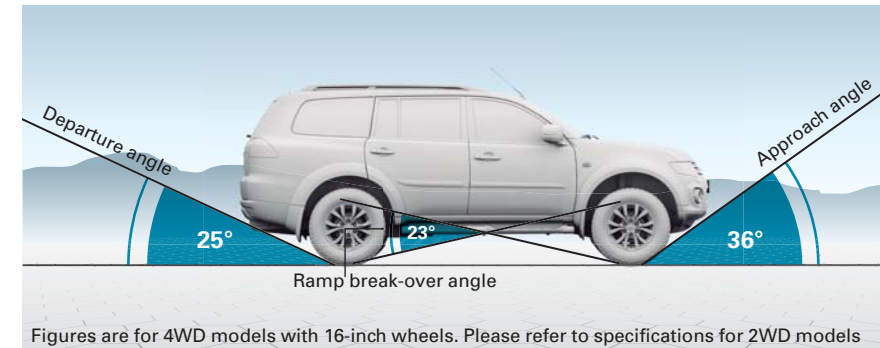

Tight minimum turning radius

Pajero Sport's remarkably tight 5.6m minimum turning radius gives drivers the ability to maneuver through tight spaces with ease.

Safety

RISE BODY

Mitsubishi's exclusive RISE (Reinforced Impact Safety Evolution) body design puts a protective framework around you and your passengers. In the event of a collision, energy is safely absorbed by crumple zones and directed around the cabin, away from occupants.

Anti-intrusion brake pedal

The brake pedal folds forward and inward during a frontal collision to help protect the driver's legs.



6-Airbag System

In addition to front SRS airbags for both driver and front passenger, curtain airbags provide added protection to first- and second-row occupants. Together with seatbelts, they provide an excellent degree of collision safety.

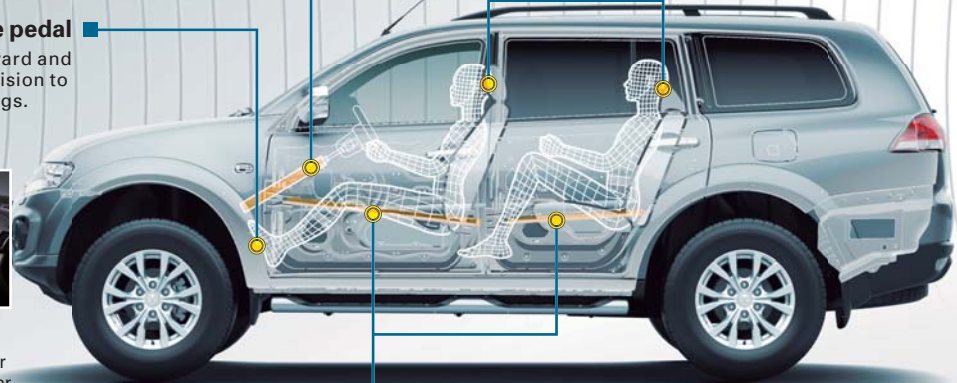

Collapsible steering column

In a forward collision, the steering column will collapse and crumple, helping to prevent injury to the driver.

ELR seatbelts with pretensioners and force-limiters

During an emergency stop, the pretensioners on the ELR (emergency locking and retractable) seat belts automatically tighten to reduce body movement. The force-limiters then gradually release to more evenly distribute stopping force, further reducing the chance of injury.

Side door impact bars

Thick side bars along the doors resist impact force in the event of a side collision, helping to protect occupants.

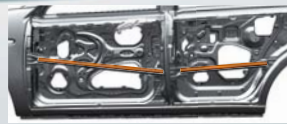

Powerful brakes with vacuum booster

For quicker stopping in all conditions, Pajero Sport features large front ventilated disc and rear drum brakes. With an added vacuum booster to multiply emergency stopping power, drivers can now feel confident and safe even when conditions turn hazardous.



Front brakes
16-inch ventilated discs



Rear brakes
11.6-inch leading and trailing drums (16-inch drum-in-disc brakes are optionally available)

Active Stability & Active Traction Control (ASTC)

ASTC utilizes a network of control units and intelligent sensors to monitor vehicle status as well as the driver's steering. As road and vehicle conditions change, ASTC manages the forces on all wheels by precisely controlling engine torque and braking force going to each one, providing improved vehicle control, trace ability and traction in all driving conditions. ASTC lets driving enthusiasts enjoy the full potential of Pajero Sport in complete confidence.

Active Stability Control (ASC)

In understeer, ASC determines appropriate yaw rate and applies braking force to the inner rear wheel to prevent drift-out and ensure better trace control.

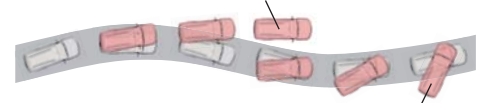

In oversteer, ASC determines appropriate counter yaw moment and applies braking force to the outer front wheel to prevent spinout and ensure better trace control.

Active Traction Control

When wheel spin is detected, engine output is governed and braking force is applied to the spinning wheels to prevent driving torque loss.

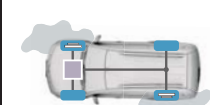

ABS with EBD

ABS keeps wheels from locking up to maintain control of the vehicle during hard emergency braking, preventing slipping and skidding. Electronic Brake-force Distribution (EBD) assists by redistributing braking force to the rear brakes as needed, enabling quicker stops even when carrying passengers and heavy loads.

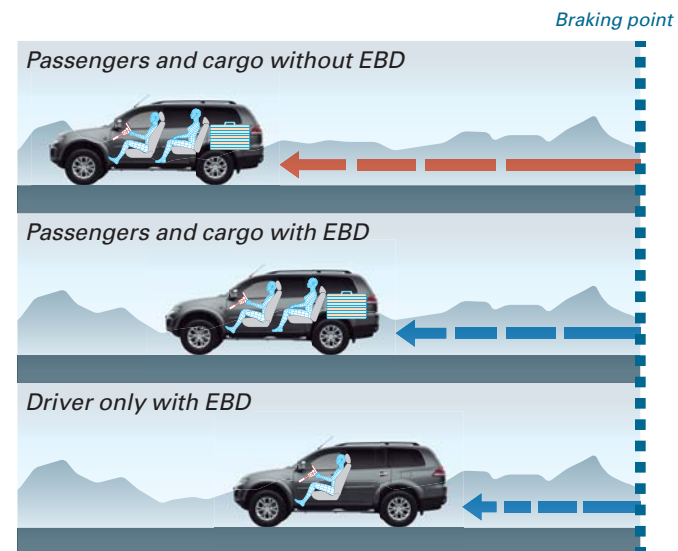

Extra-strong body construction

Pajero Sport uses high-tensile steel in key locations, creating an extra-rigid frame of beams and support pillars surrounding the cabin. The rigid beams help to direct damage around and away from the interior in the event of a collision.

- A** Collapsible A-pillars absorb collision energy, so that less reaches the cabin interior
- B** Collapsible pedals reduce the risk of leg injury to the driver
- C** Underfloor beams redirect collision energy around the cabin

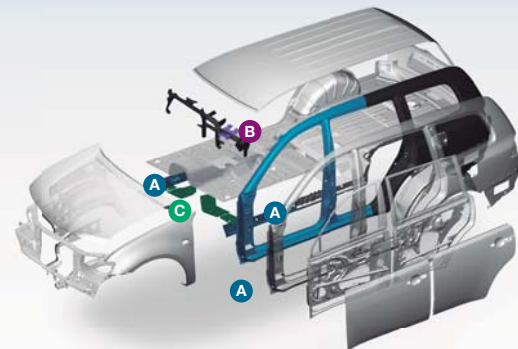

Audio Visual

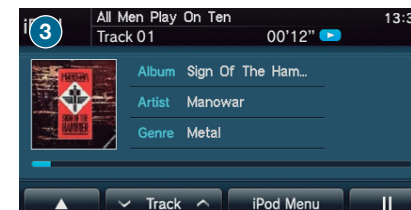

Note: Each of the above four functions are optional. Please consult your local dealer/distributor for more detailed information.

Audio System with 6.1-inch Full-color Display

Pajero Sport now features a next-generation display with 6.1-inch full-color touch screen. In addition to giving you full control over a wide range of audio options, the display also links to the rearview camera.

- 1 Easy-to-select menu**
The intuitive interface makes selecting functions safe and easy.
- 2 Rearview camera**
Safely navigate into even tight parking spaces.
- 3 USB connectivity**
Use the touch panel to select music directly from your portable player.
- 4 Hands-free Bluetooth® telephone**
Incoming calls are displayed for easy viewing.

Steering Wheel Controls

Pajero Sport features audio and Bluetooth® telephone controls built directly into the steering wheel, allowing drivers to manage their listening environment or make calls without needing to take their hands from the wheel.

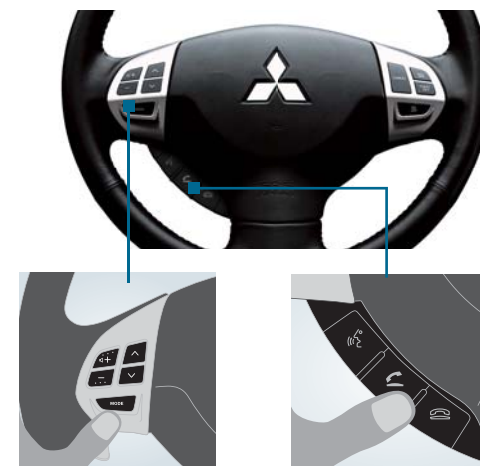

MITSUBISHI POWER SOUND SYSTEM

Mitsubishi's exclusive sound system delivers high power audio output throughout the interior. Speakers are placed for optimal sound balance and maximum enjoyment of all occupants from front to rear. Whether you prefer to listen to the radio or play your favorite CDs, MITSUBISHI POWER SOUND SYSTEM puts you squarely at center stage.



420W (Max) High Power Amp and 8-speaker System

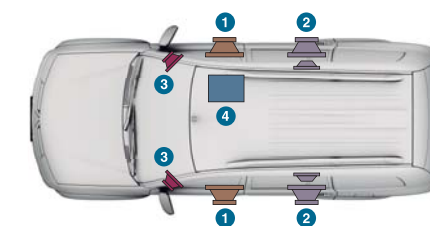

- 1** 16cm metalized hybrid PP diaphragm mid-bass speaker (front doors)
- 2** 16cm metalized hybrid PP diaphragm 2-way coaxial speaker (rear doors)
- 3** 3.5cm aluminum hard dome tweeter with ridge line
- 4** 420W (Max) 6-channel high power amplifier

Exterior

GLX



3.2-liter DI-D (4WD)
2.5-liter DI-D (4WD/2WD)
2.5-liter DI-D High Power (4WD/2WD)
(4WD shown here)
3.5-liter V6 ECI-MULTI (4WD)
3.0-liter MIVEC ECI-MULTI (2WD)



Titanium Gray Metallic [U17]

GL



2.5-liter DI-D (4WD/2WD)
(4WD shown here)
2.5-liter DI-D High Power (2WD)



Cool Silver Metallic [A66]

Interior

GLX



Black / gray interior with gray fabric seats (AT model shown)

GL



Black / beige interior with beige fabric seats

Note: Some of the equipment may vary in appearance or availability according to market. Please consult your local Mitsubishi dealer/distributor for more detailed information.

Standard and Optional Equipment

Model	Drive system	4WD				2WD				
		GLX			GL	GLX			GL	
		3.5L V6 3.2L DI-D	2.5L DI-D HP	2.5L DI-D	2.5L DI-D	3.0L V6 2.5L DI-D HP	2.5L DI-D	2.5L DI-D HP	2.5L DI-D	
Transmission	5MT ¹ /4AT	5MT/5AT	4AT	5MT	5AT	4AT	5MT	5MT/4AT		
Performance	3.5-liter 24-valve V6 SOHC ECI-MULTI engine (6G74)	■	-	-	-	-	-	-	-	
	3.0-liter 24-valve V6 SOHC MIVEC ECI-MULTI engine (6B31)	-	-	-	-	■	-	-	-	
	3.2-liter 16-valve intercooled turbocharged DOHC Common Rail DI-D engine (4M41)	■	-	-	-	-	-	-	-	
	2.5-liter 16-valve intercooled turbocharged DOHC Common Rail DI-D engine (4D56 High Power)	-	■	-	-	■	-	■	-	
	2.5-liter 16-valve intercooled turbocharged DOHC Common Rail DI-D engine (4D56 Normal Power)	-	-	■	■	-	■	-	■	
	Transmissions	5-speed manual transmission (5MT models only)	■ ¹	■	-	■	-	-	■	■
	INVECS-II 5-speed automatic transmission with Sports Mode (5AT models only)	-	■	-	-	■	-	-	-	
	INVECS-II 4-speed automatic transmission with Sports Mode (4AT models only)	■	-	■	-	-	■	-	■	
	Magnesium paddle shifters (5AT models only)	■	■	■	-	■	-	-	-	
	Super Select 4WD (SS4)	■	■	■	■	-	-	-	-	
Easy Select 4WD	-	-	-	□	-	-	-	-		
Limited-slip differential (hybrid type)	□	□	□	□	□	□	□	□		
Rear differential lock	□	□	-	-	-	-	-	-		
Tires and wheels	265/70R16 tires with 16-inch light alloy wheels	■	■	■	■	-	-	-		
	245/70R16 tires with 16-inch light alloy wheels	-	-	-	-	■	■	■		
	265/65R17 tires with 17-inch light alloy wheels	■	■	■	■	□ ²	□	□		
	245/65R17 tires with 17-inch light alloy wheels	-	-	-	-	□	□	□		
Safety	Active Stability & Active Traction Control (ASTC)	-	□	-	-	□	-	□	-	
	ABS (Anti-lock Braking System) with EBD (Electronic Brake-force Distribution)	■	■	■	■	■	■	■	■	
	SRS airbags	Driver's and front passenger's front SRS airbags	■	■	■	■	■	■	■	
		Front seat side and curtain SRS airbags	□	□	-	-	□	-	-	
	Seatbelts	Front 3-point ELR seatbelt with pretensioner and force limiter x 2	■	■	■	■	■	■	■	
		Height-adjustable front seatbelt anchors	■	■	■	■	■	■	■	
		2nd-row 3-point ELR seatbelt x 2 and 2-point center lapbelt x 1	■	■	■	■	■	■	■	
		3rd-row 3-point ELR seatbelt x 2	□	□	□	□	□	□	□	
		Side door impact bars	■	■	■	■	■	■	■	
		Child-protection rear door locks	■	■	■	■	■	■	■	
	High-mount stop lamp	■	■	■	■	■	■	■		
	Rear sensors	■	■	■	■	■	■	■		
	Shift lock with key interlock (AT models only)	■	■	■	-	■	■	-		
	Engine immobilizer	■	■	■	□	■	■	□		
	Security alarm	□	□	□	□	□	□	□		
Exterior	Chrome front grill	■	■	■	■	■	■	■		
	Gold hood ornament	□	□	□	□	□	-	□		
	Silver hood ornament	□	□	□	□	□	-	□		
	Headlamps	Halogen headlamps	■	■	■	■	■	■		
		HID headlamps with manual or auto leveling function	■	■	■	■	■	■		
		Headlamp washers	□	□	□	□	□	□		
		Auto lighting control	□	□	□	□	□	□		
	Front fog lamps	■	■	■	■	■	■	■		
	Rear fog lamp with auto-off system	■	□ ³	-	□ ³	□ ³	-	□		
	Silver front skid plate	■	■	■	■	■	■	■		
Windows	Laminated green windshield glass / Tempered green front and rear door glass and rear window glass / Rear window defogger	■	■	■	■	■	■	■		
	Windshield sunshade	□	□	□	□	□	□	□		
	Privacy glass (rear doors, rear quarter and tailgate windows)	□	□	□	□	□	□	□		
2-speed intermittent windshield wipers and washers / Rear intermittent wiper and washer	■	■	■	■	■	■	■	■		
Auto rain sensor	□	□	□	□	□	□	□	□		
Rear wiper deletion	-	-	-	□	-	-	-	□		
Black power door mirrors / Black outer door handles	■	■	■	■	■	■	■	■		
Chrome power door mirrors with side turn lamps and folding function / Chrome outer door handles	□	□	□	□	□	□	□	□		
Chrome power door mirrors with folding function / Chrome outer door handles	■	■	■	■	■	■	■	■		
Color-keyed power door mirrors with side turn lamps and folding function / Color-keyed outer door handles	□	□	□	□	□	□	□	□		
Black door sashes	■	■	■	■	■	■	■	■		
Color-keyed wide overfenders	■	■	■	■	■	■	■	■		
Color-keyed side protector moldings	■	■	■	■	■	■	■	■		
Side steps	■	■	■	■	■	■	■	■		
Front and rear mudguards	■	■	■	■	■	■	■	■		
Black roof rails	■	■	■	■	■	■	■	■		
Color-keyed tailgate garnish	■	■	■	■	■	■	■	■		
Chrome rear license plate garnish	■	■	■	■	■	■	■	■		
Chrome and color-keyed rear license plate garnish	□	□	□	□	□	□	□	□		
Front and rear towing hooks	■	■	■	■	■	■	■	■		
Cockpit	3-spoke leather-wrapped steering wheel / Leather-wrapped gearshift knob and transfer knob	■	■	■	■	■	□	□		
	3-spoke leather-wrapped steering wheel with audio controls	■	■	■	■	■	□	□		
	3-spoke urethane steering wheel / Urethane gearshift knob and transfer knob	-	-	■	■	-	■	■		
	Power steering / Tilt-adjustable steering column	■	■	■	■	■	■	■		
	Cruise control	■	■	■	■	■	■	■		
	Parking brake lever with chrome button	□	□	□	□	□	□	□		
	Back-lit meters and gauges with tachometer, chrome rings and rheostat	■	■	■	■	■	■	■		
	Back-lit meters and gauges with tachometer and black rings	-	-	-	□	-	-	-		
	Illuminated ignition key cylinder	■	■	■	■	■	■	■		

Model	Drive system	4WD				2WD			
		GLX			GL	GLX			GL
		3.5L V6 3.2L DI-D	2.5L DI-D HP	2.5L DI-D	2.5L DI-D	3.0L V6 2.5L DI-D HP	2.5L DI-D	2.5L DI-D HP	2.5L DI-D
Transmission	5MT ¹ /4AT	5MT/5AT	4AT	5MT	5AT	4AT	5MT	5MT/4AT	
Seats	Leather seats / Driver's power seat	■	■	-	-	□	-	-	-
	Fabric (water-repellent)	■	■	■	■	■	■	■	■
	Fabric (non-water-repellent)	-	-	-	□	-	-	-	□
	Front seats	Manual sliding and reclining adjusters / Height-adjustable headrest x 2	■	■	■	■	■	■	■
		Driver's seat height adjuster	■	■	□	□	■	□	□
		Front passenger's seatback pocket / Driver's and front passenger's seatback convenience hooks	■	■	■	■	■	■	■
	2nd-row seats	60:40 split seats / Reclining adjusters / Manual folding and tumbling function	■	■	■	■	■	■	■
		Center armrest with cup holders / Height-adjustable headrest x 2	■	■	■	■	■	■	■
	3rd-row seats	50:50 split bench seat / Double-action manual folding function / Height-adjustable headrest x 2	□	□	□	□	□	□	□
	Interior	Silver instrument accent panels / Carbon-like accent panel, floor console and door trims	■	■	■	■	■	■	■
Silver and wood-print instrument accent panels / Wood-print floor console accent panels / Wood-print door trim accent panels		□	□	□	□	□	□	□ ⁴	
Matte silver accent panels (instrument panel, floor console and door trims)		-	-	-	□	-	-	-	
Silver gearshift panel (AT models only)		■	■	■	-	■	■	-	
Chrome inner door handles		■	■	■	■	■	■	■	
Silver power window switch panels		■	■	■	■	■	■	■	
Digital quartz clock / Upper instrument panel box with lid		-	-	■	■	-	■	■	
Multi-mode center information display		■	■	□	□	■	□	□	
Lockable and illuminated glove box / Front cup holders on floor console		■	■	■	■	■	■	■	
Floor console box with lid (small armrest type)		-	-	-	□	-	-	-	
Floor console box with lid (large armrest type)	■	■	■	■	■	■	■		
Front door pockets with bottle holders / Rear door bottle holders / 3rd-row right side cup and bottle holders	■	■	■	■	■	■	■		
Accessory socket inside floor console box	■	■	■	■	■	■	■		
Cigarette lighter / Removable cup-type ashtray / Removable cup-type ashtray (for rear seats)	■	■	■	■	■	■	■		
Sunglasses pocket on ceiling	■	■	■	■	■	■	■		
Fuel lid opener	■	■	■	■	■	■	■		
Vanity mirror with lid for sunvisors / Ticket holder for driver's sunvisor	■	■	■	■	■	■	■		
Front room lamp with map lamps / Rear room lamp / Door courtesy lamps (all side doors)	■	■	■	■	■	■	■		
Electronic chromic rearview mirror	■	■	■	■	■	■	■		
Day-and-night rearview mirror	■	■	■	■	■	■	■		
Retractable assist grip x 3 / Coat hanger x 2	■	■	■	■	■	■	■		
Retractable assist grip x 5 / Coat hanger x 2	□	□	□	□	□	□	□		
Cargo room	Cargo room floor box / Cargo room hook x 2	□	□	□	□	□	□		
	Cargo room hook x 4 / Cargo room accessory socket / Cargo room lamp	■	■	■	■	■	■		
	Tonneau cover	□	□	□	□	□	□		
	Cargo room net	□	□	□	□	□	□		
Comfort and Convenience	Ventilation	Manually controlled air conditioner	■	■	■	■	■	-	■ ³
		Fully automatic air conditioner	□	□	□	□	□	□	□
		Manually controlled cooler	-	-	-	-	-	■	-
		Manually controlled rear cooler	■	■	■	■	■	■	■ ⁵
		2nd-row seat heater ducts	□	□	□	□	□	-	□ ³
	Central door locking system	■	■	■	■	■	■	■	■
	Keyless entry system	■	■	■	□	■	■	□	□
	Power windows	■	■	■	■	■	■	■	■
	Power tilt and sliding sunroof with anti-trapping function	□	□	□	□	□	□	□	□
	Full tool and jack set	□	□	□	□	□	□	□	□
Audio and Media	4 speakers	■	■	■	■	■	■	■	■
	6 speakers (4 speakers and 2 tweeters)	□	□	□	□	□	□	□	□
	420W MITSUBISHI POWER SOUND SYSTEM (set option with AM/FM radio, CD player, MP3, 8 speakers in 6 locations (6 speakers and 2 tweeters) and auxiliary audio jack)	□	□	□	□	□	□	□	□
	420W MITSUBISHI POWER SOUND SYSTEM (set option with AM/FM radio, CD player featuring touch panel center display, digital clock, audio information and rearview camera, MP3, 8 speakers in 6 locations (6 speakers and 2 tweeters) and auxiliary audio jack)	□	□	□	□	□	□	□	□
	AM/FM radio, CD player with center display with touch panel (digital clock, audio information and rearview camera), MP3 and auxiliary audio jack	■	■	■	■	■	■	■	■
	AM/FM radio, CD player with center display with touch panel (digital clock, audio information and rearview camera) and MP3	□	□	□	□	□	□	□	□
	AM/FM radio, CD player with center display (digital clock and audio information), MP3 and auxiliary audio jack	□	□	□	□	□	□	□	□
	AM/FM radio, CD player with center display (digital clock and audio information) and MP3	■	■	■	■	■	■	■	■
	Rearview camera (set option with AM/FM radio, CD player, center display with touch panel and MP3)	□	□	□	□	□	□	□	□
	USB port	□	□	□	□	□	□	□	□
Bluetooth® hands-free cellular phone interface system with voice recognition and USB port / Link system	□	□	□	□	□	□	□	□	
Roof antenna	■	■	■	■	■	■	■	■	

■ : Standard □ : Optional - : Not available *1: 3.5-liter model only *2: 2.5-liter High Power models only *3: LHD models only *4: AT models only *5: RHD models only
Note: Some of the equipment may vary in appearance or availability according to market. Please consult your local dealer/distributor for more detailed information.

Standard and Optional Equipment

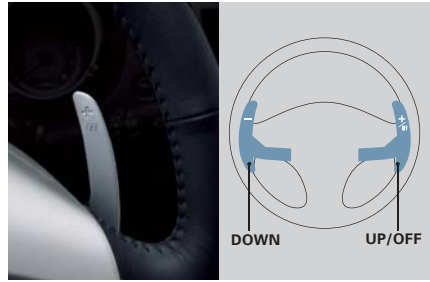

Magnesium paddle shifters 01



265/70R16 tires with 16-inch light alloy wheels 02



265/65R17 tires with 17-inch light alloy wheels 03



Side steps 16



Black roof rails 17



Top: Chrome rear license plate garnish
Bottom: Chrome and color-keyed rear license plate garnish 18



2nd-row 3-point ELR seatbelt x 2 and 2-point center lapbelt x 1 04



High-mount stop lamp 05



Rear sensors 06



3-spoke leather-wrapped steering wheel with audio controls and cruise control 19



Driver's power seat 20



Carbon-like floor console accent panel / Silver gearshift panel 21



Chrome front grill 07



Gold and silver hood ornaments 08



HID headlamps with manual or auto leveling function 09



Wood-print floor console accent panel / Silver gearshift panel 22



Chrome inner door handles 23



Multi-mode center information display 24



Headlamp washers 10



Front fog lamps 11



Rear fog lamp with auto-off system 12



Accessory socket inside floor console box 25



Front room lamp with map lamps 26



Electronic chromic rearview mirror 27



Rear intermittent wiper and washer 13



Chrome power door mirrors with folding function 14



Color-keyed side protector moldings 15



Manually controlled rear cooler 28



AM/FM radio and CD player with MP3 accommodation 29



AM/FM radio, CD player with center display with touch panel with MP3 accommodation 30

Note: Some of the equipment may vary in appearance or availability according to market. Additional items shown are for illustration purposes only. Please consult your local dealer/distributor for more detailed information.

4WD Specifications

MODEL	Drive system		4WD									
	Engine		3.5 V6		3.2 DI-D		2.5 DI-D High Power		2.5 DI-D			
Price class		GLX		GLX		GLX		GLX		GL		
Transmission		5-speed manual		INVECS-II 4-speed automatic with Sports Mode		INVECS-II 4-speed automatic with Sports Mode		5-speed manual		INVECS-II 4-speed automatic with Sports Mode		
Model code	LHD	EURO 2 or EURO 4 or EURO 5	-	-	-	-	-	KH4WGNPZL	KH4WGYZL / KH4WGYNZL***	-	-	
		EURO 2 or EURO 4	KH9WGNPEL	KH9WGRPEL	-	-	-	-	-	-	-	
		EURO 2 or EURO 3	-	-	-	-	-	-	-	-	KH4WGNMZL	
		EURO 3	-	-	KH8WGRPZL	-	-	-	-	-	-	
	RHD	EURO 2 or EURO 3	-	-	-	-	-	-	-	KH4WGRPZR	KH4WGNMZR	
		EURO 2	-	-	-	-	-	-	KH4WGPZR / KH4WGYNZR***	-	-	
DIMENSIONS AND WEIGHTS	Overall length	mm	4,695									
	Overall width	mm	1,815									
	Overall height	mm	1,800 (with roof rails: 1,840)									
	Wheelbase	mm	2,800									
	Ground clearance	mm	215									
	Curb weight (5-seater / 7-seater)	kg	1,925 / 1,975	1,930 / 1,975	2,025 / 2,075	1,985 / 2,035	1,990 / 2,040	1,985 / 2,030	1,975 / 2,025 (LHD) 1,980 / 2,025 (RHD)			
	Gross vehicle weight	kg	2,600			2,710						
Seating capacity	persons	5/7*										
PERFORMANCE	Max. speed**	km/h	179	175	178	179	176	164	167			
	Max. climbing ability	tanθ	0.7									
	Approach angle		36°									
	Ramp break-over angle		23°									
	Departure angle		25°(with 265/65R17 tires: 24°)									
	Min. turning radius	m	5.6									
	ENGINE	Type (code)	3.5-liter 24-valve V6 SOHC (6G74)			3.2-liter 16-valve intercooled turbocharged DOHC Common Rail DI-D (4M41)		2.5-liter 16-valve intercooled turbocharged DOHC Rail DI-D (High-Power) (4D56)		2.5-liter 16-valve intercooled turbocharged DOHC Common Rail DI-D (4D56)		
Displacement		cc	3,497			3,200		2,477		2,477		
Max. output (EEC net)		kW (PS)/rpm	137 (186) / 4,750			120 (163) / 3,500		131 (178) / 4,000 (EURO 2.4) 131 (178) / 3,750 (EURO 5)		100 (136) / 3,500		
Max. torque (EEC net)		N-m (kg-m)/rpm	303 (30.9) / 3,750			343 (35.0) / 2,000		400 (40.8) / 2,000-2,850		350 (35.7) / 1,800-3,500		
FUEL SYSTEM	Fuel supply equipment	ECI-MULTI (Electronic Controlled Injection - Multi Point Injection)						Electronic		Common Rail Direct Injection		
	Fuel tank capacity	liters	70									
DRIVE SYSTEM	Type	Super Select 4WD (SS4)						Super Select 4WD (SS4) / Easy Select 4WD*				
STEERING	Type	Rack-and-pinion, power assisted										
	Front	Double-wishbone, coil springs with stabilizer bar										
SUSPENSIONS	Rear	3-link, coil springs with stabilizer bar										
	Front	16-inch ventilated discs										
BRAKES	Rear	11.6-inch leading-and-trailing drums (16-inch drum-in-discs*)										
	Front and rear	265/70R16 (265/65R17*)										

*Available as an option ** Measured by Mitsubishi Motors Corporation *** High safety performance model
Note: These specifications are subject to change without notice. Please consult your local Mitsubishi dealer/distributor for more detailed specifications.

Dimensional views (4WD)

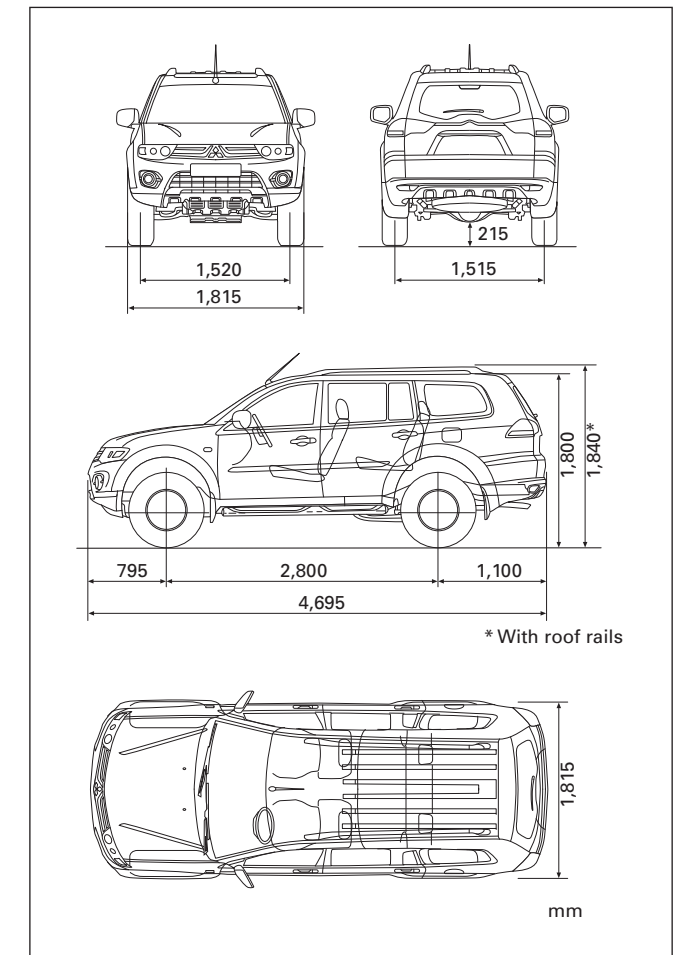

2WD Specifications

MODEL	Drive system		2WD							
	Engine		3.0 V6 MIVEC		2.5 DI-D High Power		2.5 DI-D			
Price class		GLX		GLX		GL		GL		
Transmission		INVECS-II 5-speed automatic with Sports Mode		INVECS-II 5-speed automatic with Sports Mode		5-speed manual		INVECS-II 4-speed automatic Sports Mode		
Model code	LHD	EURO 2 or EURO 4 or EURO 5	-	-	-	-	-	-	-	
		EURO 2 or EURO 4	KG6WGYPL	-	-	-	-	-	KG4WGNMZL	
		EURO 2 or EURO 3 or EURO 4 or EURO 5	-	-	-	-	-	-	-	
		EURO 2	-	KG4WGYPSL	KG4WGNMSL	-	-	-	-	
	RHD	EURO 2 or EURO 3	-	-	-	-	KG4WGRPZR	-	-	
		EURO 2	KG6WGYPR	KG4WGYPSR	-	-	-	KG4WGNMZR	-	
DIMENSIONS AND WEIGHTS	Overall length	mm	4,695							
	Overall width	mm	1,815							
	Overall height	mm	1,790 (with roof rails: 1,825)		With 245 tires: 1,790 (with roof rails: 1,825)		/ With 265 tires: 1,800 (with roof rails: 1,840)			
	Wheelbase	mm	2,800							
	Ground clearance	mm	205		With 245 tires: 205		/ With 265 tires: 215			
	Curb weight (5-seater / 7-seater)	kg	1,790 / 1,840	1,850 / 1,900 (LHD) 1,850 / 1,905 (RHD)	1,840 / 1,895	1,845 / 1,895	1,840 / 1,890	1,845 / 1,895		
	Gross vehicle weight	kg	2,505		2,600		2,650		2,710 (LHD) / 2,600 (RHD)	
Seating capacity	persons	5/7*								
PERFORMANCE	Max. speed**	km/h	179	177	179	164	167	164		
	Approach angle		34°		With 245 tires: 34°		/ With 265 tires: 36°			
	Ramp break-over angle		22°		With 245 tires: 22°		/ With 265 tires: 23°			
	Departure angle		24°		With 245 and 265/65R17 tires: 24°		/ With 265/70R16 tires: 25°			
	Min. turning radius	m	5.6							
	ENGINE	Type (code)	3.0-liter 24-valve V6 SOHC MIVEC (6B31)		2.5-liter 16-valve intercooled turbocharged DOHC Common Rail DI-D (High-Power) (4D56)		2.5-liter 16-valve intercooled turbocharged DOHC Common Rail DI-D (4D56)			
		Displacement	cc	2,998				2,477		
Max. output (EEC net)		kW (PS)/rpm	162 (220) / 6,250 (EURO 2) 163 (222) / 6,250 (EURO 4)		131 (178) / 4,000				100 (136) / 3,500 (EURO 2, 3, 4) 100 (136) / 4,000 (EURO 5)	
Max. torque (EEC net)		N-m (kg-m)/rpm	281 (28.7) / 4,000		350 (35.7) / 1,800-3,500		400 (40.8) / 2,000-2,850		314 (32.0) / 2,000 (EURO 2.3, 4) 314 (32.0) / 1,500 - 2,680 (EURO 5)	
FUEL SYSTEM	Fuel supply equipment	ECI-MULTI (Electronic Controlled Injection - Multi Point Injection)		Electronic		Common Rail Direct Injection				
	Fuel tank capacity	liters	70							
DRIVE SYSTEM	Type	2WD								
STEERING	Type	Rack-and-pinion, power assisted								
	Front	Double-wishbone, coil springs with stabilizer bar								
SUSPENSIONS	Rear	3-link, coil springs with stabilizer bar								
	Front	16-inch ventilated discs								
BRAKES	Rear	11.6-inch leading-and-trailing drums (16-inch drum-in-discs*)								
	Front and rear	245/70R16 (245/65R17*)		245/70R16		(245/65R17*, 265/70R16*, 265/65R17*)				

*Available as an option ** Measured by Mitsubishi Motors Corporation
Note: These specifications are subject to change without notice. Please consult your local Mitsubishi dealer/distributor for more detailed specifications.

3.5-liter 24-valve V6 SOHC ECI-MULTI (6G74)

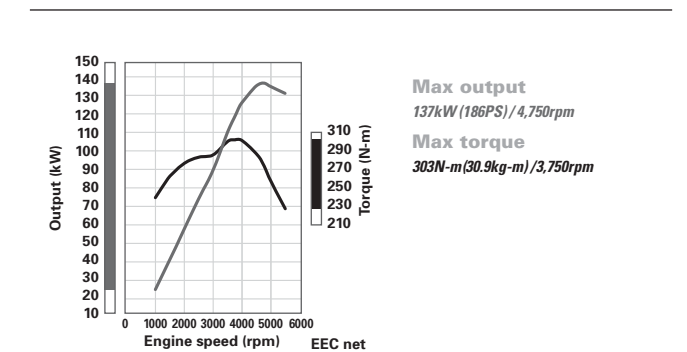

3.0-liter 24-valve V6 SOHC MIVEC (6B31)

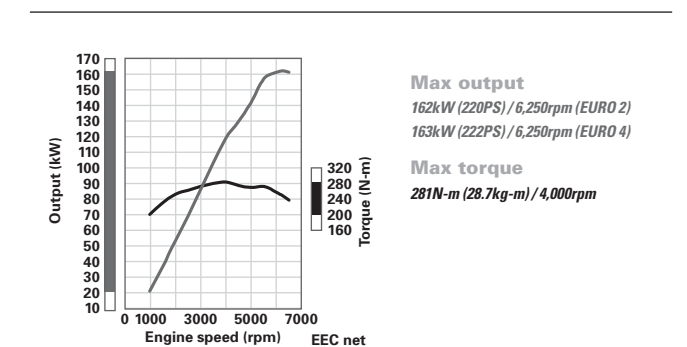

Body Colors



Cool Silver Metallic [A66]



Quartz Brown Metallic [C06]



Medium Red [P17]



Deep Blue Mica [T64]



Titanium Gray Metallic [U17]



White Pearl [W54]



Black Mica [X08]

Seat Materials



Beige leather



Gray leather

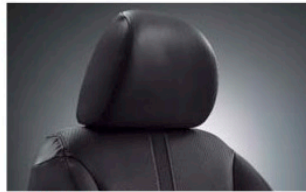

Black leather



Beige fabric (water repellent)



Gray fabric (water repellent)

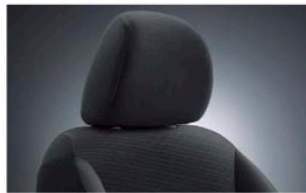

Black fabric (water repellent)



Gray fabric (non-water-repellent)

Exterior And Interior Color Combinations

Interior colors		Black / beige interior with beige seats	Black / gray interior with gray seats	Black / gray interior with black seats
Seat materials	Fabric (water-repellent) (GLX/GL)	■	■	■
	Fabric (non-water-repellent) (GL)	—	□	—
	Leather (GLX)	□	□	□
Exterior colors	Cool Silver Metallic [A66]	■	■	■
	Quartz Brown Metallic [C06]	■	■	■
	Medium Red [P17]	■	■	■
	Deep Blue Mica [T64]	■	■	■
	Titanium Gray Metallic [U17]	■	■	■
	White Pearl [W54]	■	■	■
	Black Mica [X08]	■	■	■

■ : Standard □ : Optional — : Not available

Note: Colors shown may differ slightly from actual colors due to printing process. Please consult your dealer/distributor for actual colors.



MiEV Facebook Page

This facebook page introduces latest MiEV (Mitsubishi innovative Electric Vehicle) activities, hot news, and voice from fans and owners. The MiEV supporters mark represents the fans who support and participate in MiEV activities, so join the club to be a part of the fun and excitement. Check us out on facebook on the right.



www.facebook.com/iMiEV.official



MITSUBISHI MOTORS
www.mitsubishi-motors.com



The paper used in this catalogue has been certified by the FSC™ (Forest Stewardship Council™) as having been produced through a 'chain of custody' system of forestry management, tracking and production oversight that ensures responsible consideration for the earth's ecosystem. Mitsubishi Motors Corporation has adopted the combined use of FSC-certified paper and recycled paper in our efforts to reduce CO₂ emissions and promote more efficient use of natural resources. In this way, we hope to contribute to greater protection of the environment.