

Audi Sport Performance Cars



 Audi Sport

*YOU CAN'T
THINK
EMOTIONS.*

THAT'S WHY YOU NEED TO EXPERIENCE THEM.

Be someone who is tireless, pioneering and inspired. Be someone who is always looking to make the impossible possible.

And then create that future. Be one of the designers, the model builders, the engineers, the test drivers, the racing drivers and the crew.

Be prepared, be focused, be fast.

Be in a suit Monday to Friday – but be on the racetrack on Saturday.

Be part of an everlasting challenge – be someone whose success only drives them to even bigger triumphs.

A vision that sees opportunities where others see nothing.

JOIN THE LEAGUE OF PERFORMANCE.



 **LEAGUE OF
PERFORMANCE**

**BORN
ON THE
RACETRACK.
BUILT FOR
THE ROAD.**

The Audi R8 Coupé V10 plus.

It was created in the world's most demanding development laboratory: motorsport. About 50 percent of all components that are used for the Audi R8 are based on motor racing technology. The sprint from 0 to 100 km/h takes just 3.2 seconds thanks to the powerful 5.2-litre V10 FSI engine with 449 kW and the 7-speed S tronic, before going on to a top speed of 330 km/h. From the powerful engine and quattro drive, the intelligent lightweight construction to the aerodynamic design: the R8 Coupé V10 plus proves that it would be virtually impossible to add to this already enhanced performance.

The figures for fuel consumption and CO₂ emissions can be found on page 46.



A plus in performance. And a clear statement of sportiness. Numerous carbon details emphasise the striking motor racing looks of the Audi R8 Coupé V10 plus. 19-inch forged aluminium wheels and ceramic brakes are further evidence of its athletic prowess. Just like the cockpit where everything is geared to what's essential: the driver. Starting the engine, driving dynamics, engine sound, infotainment or gear-change commands – all can be controlled directly via the R8 performance leather steering wheel with four operating satellites. The Audi virtual cockpit also focuses on the driver. The 12.3-inch TFT screen brilliantly displays a host of important information in high contrast. The way in which content is displayed can be adjusted to your individual needs. The R8 bucket seats in exquisite fine Nappa leather add the perfect finishing touch to the interface between driver and vehicle. Thanks to their heavily contoured bolsters and the integrated head restraints, they emphasise the sporty character of the interior and provide excellent lateral support. For a driving experience that redefines sportiness.

The figures for fuel consumption and CO₂ emissions can be found on page 46.



THE COMBINATION OF POWER AND ELEGANCE.

The Audi R8 Coupé V10.

However you look at it, the Audi R8 Coupé V10 is unmistakable. Each line embodies pure aesthetics and emphasises that this R8 is a high-performance sports car. A brief touch of the accelerator is sufficient for the 5.2-litre V10 FSI engine to harness its 397 kW of power and maximum torque of 540 Nm to race from 0 to 100 km/h in just 3.5 seconds, before going on to a top speed of 320 km/h. This way, the Audi R8 Coupé V10 demonstrates on every journey that concentrated power and elegance do indeed go hand in hand.

The figures for fuel consumption and CO₂ emissions can be found on page 46.



10 cylinders at the centre of attention.

A stylish display of power: the V10 mid-engine is set like a jewel under the rear window and is even illuminated on request. The central position of the engine results in superb vehicle balance and improved road handling. No matter whether you are driving along straight roads, round bends or at high speed – the R8 Coupé V10 offers breathtaking driving enjoyment. Every line embodies timeless elegance and emphasises the unconventional design. From the muscular side lines to the athletic rear. And the exclusive interior is just as impressive as the exterior. Every detail meets high expectations. Both functional and aesthetic – such as the R8 sport seats, optionally available in exquisite fine Nappa leather with diamond pattern. Choose from a total of 28 different colour combinations and set your very own tone in the cockpit.

The figures for fuel consumption and CO₂ emissions can be found on page 46.



FREEDOM INTENSIFIED.

The Audi R8 Spyder V10.



A supercar for limitless intensity: the Audi R8 Spyder V10. Its V10 mid-engine with a displacement of 5.2 l, 397 kW of power and a maximum torque of 540 Nm will win you over from the word go. With an impressive sound, the high-performance sports car accelerates from 0 to 100 km/h in just 3.6 seconds. A very special experience with the hood open. The acceleration levels out at a top speed of 318 km/h. Leaving you to savour the feeling of endless freedom.

The figures for fuel consumption and CO₂ emissions can be found on page 46.



Turning the wind in your hair into a frenzy of enthusiasm.

And opening up new perspectives to the driver: the fully automatic hood. On the Audi R8 Spyder V10, the finned hood can be opened fully automatically and conveniently at vehicle speeds of up to 50 km/h. At the push of a button, the cloth roof is stowed away completely under the hood compartment lid, which is made of ultralight carbon fibre, in just 20 seconds. The interior holds even more exhilaration in store, with the monoposto design specifically geared towards the driver. From the Audi virtual cockpit and optional R8 performance leather steering wheel with multifunction plus and four operating satellites to the R8 sport seats in optional fine Nappa leather with diamond pattern. On request, the standard R8 sport seats or the optional R8 bucket seats come with four Bang & Olufsen loudspeakers in the head restraints. For an unforgettable sound. Even beyond the 200 km/h mark.

The figures for fuel consumption and CO₂ emissions can be found on page 46.





DON'T FORGET TO BREATHE.

The Audi TTRS Coupé.

Take a deep breath. The very sight takes your breath away: the Audi TTRS Coupé. The Audi design icon, sharpened with characteristic RS features. Audi Singleframe with honeycomb grille and quattro logo. Striking RS bumper with characteristic air inlets. A powerful and athletic impression that is confirmed by the driving performance. Are you ready for this much adrenalin?

The figures for fuel consumption and CO₂ emissions can be found on page 47.



294 arguments. No discussion. Start the engine. Get in gear. Accelerate. Breathtaking driving dynamics combined with impressive sound – thanks to the redeveloped 5-cylinder engine. With 294 kW power output and up to 480 Nm of torque, the Audi TT RS Coupé sprints from 0 to 100 km/h in just 3.7 seconds. And accelerates further to reach a top speed of 250 km/h¹. Or even 280 km/h¹ on request. With everything in view: the Audi virtual cockpit displays all key information on a high-resolution 12.3-inch screen. The pièce de résistance comes in the shape of sport mode with central rev counter and racing gauges such as lap timer, engine power/torque or charge pressure. Supplemented by RS-specific functions: G-meter, shift light and optionally tyre pressure or tyre temperature. Combined with RS sport seats, optionally in fine Nappa leather with coloured perforation and diamond pattern. Also accentuated with a coloured RS design package on request. Turning every bend into a moving experience.

The figures for fuel consumption and CO₂ emissions can be found on page 47.

¹Electronically regulated.

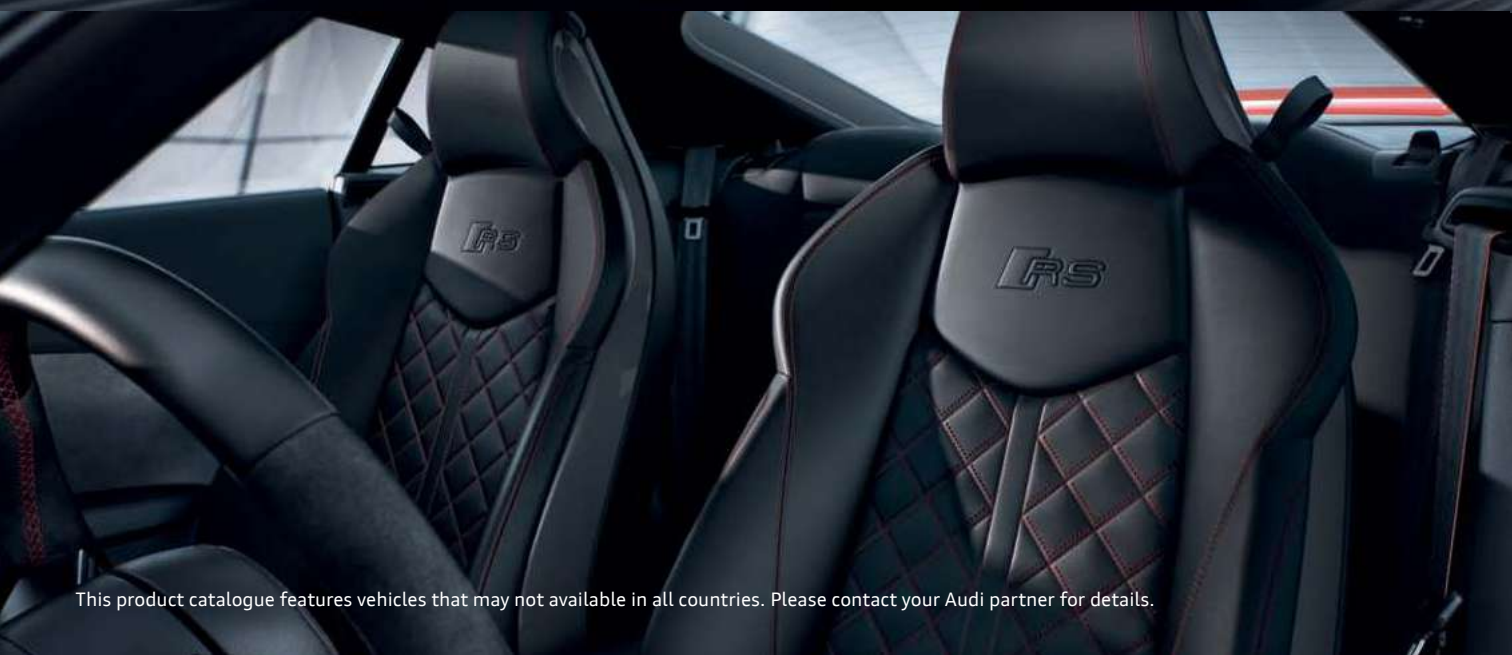



EVERY JOURNEY A REVELATION.

The Audi TTRS Roadster.

Created to intensify your experience of the world: the Audi TTRS Roadster promises undiluted driving enjoyment even when stationary. Open or close the hood in just 10 seconds at vehicle speeds of up to 50 km/h. From 0 to 100 km/h in 3.9 seconds. Audi drive select provides various takes on the driving experience thanks to adjustable vehicle components. Standard for engine characteristics, gear mode, quattro permanent all-wheel drive, steering torque and exhaust flap control. Preconfigured in the comfort, auto and dynamic modes. Free configuration in individual mode. The same goes for the optional RS sport suspension plus with Audi magnetic ride. With three different suspension settings, from balanced-rolling to sporty-direct. Ideal for turning every moment into an extraordinary experience.

The figures for fuel consumption and CO₂ emissions can be found on page 47.



Turns heads. Blows minds. The interior of the Audi TTRS Roadster: design that exudes sportiness. And lets you feel it. Right from the moment you sit in the contoured RS sport seats with their high-grade leather upholstery and trim. Surrounded by flawless, ingenious details such as the RS sport leather steering wheel with multifunction plus and two operating satellites. Precise workmanship. Unmistakeable on request: with the Audi exclusive customisation options. With freely combinable colours and materials or preconfigured as a design package in Audi exclusive fine Nappa leather, palomino brown. Whatever you want and wherever you want to go, the Audi TTRS Roadster provides you with a multitude of options.

THIS IS WHAT RACING LINES LOOK LIKE.

The Audi RS 3 Sportback.



The Audi RS 3 Sportback shows itself to be in top form from any angle. In addition to the wide wheel housings and sills, the RS roof edge spoiler, RS bumpers, striking diffuser inserts and the optional RS sport exhaust system with black tailpipe trims demonstrate pure sportiness. The 19-inch cast aluminium wheels in 5-arm rotor design and the optional ceramic brake at the front also illustrate the athleticism of this Performance Sportback.

The figures for fuel consumption and CO₂ emissions can be found on page 47.

Will impress you at record speed.

Thanks to the powerful 5-cylinder TFSI with 294 kW and up to 480 Nm, the Audi RS 3 Sportback needs only 4.1 seconds to break through the 100 km/h mark from a standing start. Only the powerful design will impress you faster. The Audi Singleframe with the grille in three-dimensional honeycomb design and quattro logo, not to mention the contoured RS bumpers, are expressions of outstanding dynamism. The optional gloss black styling package enables you to create additional accents on the front spoiler, around the Audi Singleframe and the trim strips on the side windows. Making performance visible at a glance. Even if the new Audi RS 3 Sportback disappears out of sight in the blink of an eye.

The figures for fuel consumption and CO₂ emissions can be found on page 47.



Always in pole position. No matter where you sit. Create unmistakable accents with the RS design package and make the interior of your Audi RS 3 even more sporty. With door armrests in artificial leather, black, and knee pads in Alcantara, black, both with dynamite red stitching. The floor mats are also finished with contrasting stitching in dynamite red, additionally with embroidered RS logos in the front. The black seat belts with red edges and the red accent rings on the air vents in the instrument panel round off the sporty interior. Making it clear when you get in: just taking a seat means you've already won.



*THE HEART
OF AN ATHLETE.
IN THE BODY
OF A SALOON.*

The Audi RS 3 Saloon.

Outstanding performance meets powerful design: the Audi RS 3 Saloon will impress you with its combination of 5-cylinder power and characteristic RS features. The 2.5-litre TFSI engine with 294 kW catapults the saloon from 0 to 100 km/h in just 4.1 seconds. On request up to a top speed of 280 km/h¹. No less impressive are its sporty attributes that signal power and performance even at a distance. The Audi Singleframe with grille in gloss black honeycomb design and quattro logo, the striking RS bumpers, flared wings and 19-inch wheels in 5-arm blade design. Numerous highlights that will thrill you just as fast as the Audi RS 3 Saloon accelerates.

The figures for fuel consumption and CO₂ emissions can be found on page 47.



A particular kind of sporty experience: the driving dynamics of the Audi RS3 Saloon. Thanks to the 5-cylinder engine, S tronic that changes gears at lightning speed, and quattro permanent all-wheel drive. And so you can enjoy the breathtaking performance just the way you like it, the standard Audi drive select allows you to adjust your vehicle's character. What's more, you can influence many vehicle components simply at the push of a button: engine characteristics, exhaust flap control, gear change points, the quattro torque distribution and the steering torque of the progressive steering can all be varied. On request so can the damper hardness of the RS sport suspension plus with Audi magnetic ride. For more dynamism and fewer compromises.

The figures for fuel consumption and CO₂ emissions can be found on page 47.



PERFORMANCE PERSONIFIED.

The Audi RS 5 Coupé.

The Audi RS 5 Coupé commands respect right from first sight. As indeed do the facts: 331 kW and 600 Nm from a 2.9-litre V6 biturbo engine. Awe-inspiring acceleration assured by the 8-speed tiptronic. Converted directly into propulsive power by quattro permanent all-wheel drive. In figures: 0 to 100 km/h in 3.9 seconds. A top speed on request of up to 280 km/h¹. JOIN THE LEAGUE OF PERFORMANCE.

The figures for fuel consumption and CO₂ emissions can be found on page 48.



Reflected in every detail: BURSTING WITH CHARACTER. A character in its own right. The Audi RS 5 Coupé elegantly combines aesthetic appeal with a design idiom that is characteristically RS. The broadened body, the RS bumpers and the discreet rear spoiler accentuate the athletic exterior. An exterior which can be individually modified on request with styling packages in matt aluminium, gloss black or exquisite carbon. Optionally combined with a carbon roof or carbon exterior mirror housings.



One of the most coveted sporting venues: DRIVER SEAT. The optional Audi virtual cockpit keeps the driver informed via clear, high-resolution displays. They include RS-specific content such as the G-meter, shift light or, on request, tyre pressure or tyre temperature. The RS sport seats at the front – optionally available in fine Nappa leather with honeycomb pattern in a contrasting colour – are an expression of pure sportiness. If desired, the RS design package can add additional accents in black Alcantara and red contrasting stitching on the controls and the centre console. For a vehicle character that accurately reflects your personality.

The figures for fuel consumption and CO₂ emissions can be found on page 48.



*LESS
RATIONALITY.
MORE FEELING.*

The Audi RS 6 Avant.

Give in to your enthusiasm. The Audi RS 6 Avant invites you to do just that: clear lines define its muscular stature. Hallmark RS design elements accentuate the athletic exterior. Its 4.0-litre V8 TFSI engine with 412 kW and 700 Nm of torque makes the RS 6 Avant irresistibly dynamic. It accelerates powerfully from 0 to 100 km/h in 3.9 seconds. For drivers looking for more: the Audi RS 6 Avant performance. Upgraded to 445 kW. Even more powerful thanks to the overboost function. The maximum torque is temporarily increased to 750 Nm. Taking just 3.7 seconds to complete the standard sprint. On request up to a top speed of 305 km/h¹. Here you can sense that the most impressive equipment characteristic is hidden under the bonnet.

The figures for fuel consumption and CO₂ emissions can be found on page 48.



More exclusivity. Fewer effects. Illuminated door sill trims welcome you into the Audi RS 6 Avant and stylish carbon inlays emphasise the sporty atmosphere of the interior. A honeycomb pattern decorates the RS sport seats, available in Valcona leather on request, the contoured shape of which provides excellent lateral support. The RS multifunction sport leather steering wheel in 3-spoke design, flattened at the bottom, with shift paddles in aluminium look provides good grip when steering and changing gear. High-quality materials are worked with meticulous attention to detail. And can be tailored to your own expectations thanks to various colour combinations or design packages. It's hard to express in just a few words how versatile the Audi RS 6 Avant is; it has to be experienced – with lots of enthusiasm. Climb in.

The figures for fuel consumption and CO₂ emissions can be found on page 48.

POWERFUL PROPULSION. SPORTY UNDERSTATEMENT.

The Audi RS 7 Sportback.



Top-class sportiness. With an elegant athlete from the luxury class: the Audi RS 7 Sportback. A statement of understatement. Its 4.0 litre V8 TFSI engine generates 412 kW and delivers maximum torque of 700 Nm. The sprint from 0 to 100 km/h is effortless and takes just 3.9 seconds. The updated Audi RS 7 Sportback performance hits the 100-km/h mark after a mere 3.7 seconds. Upon request, the top speed can be raised to 305 km/h¹. The quattro permanent all-wheel drive uncompromisingly transfers the phenomenal 445 kW of power onto the road. The overboost function with a brief torque increase to 750 Nm delivers instantaneous dynamism. Figures that call for a deep breath.

The figures for fuel consumption and CO₂ emissions can be found on page 49.

¹ Electronically regulated.

This product catalogue features vehicles that may not be available in all countries. Please contact your Audi partner for details.

The centre of exclusivity: the interior.

Fine materials. First-class workmanship. Take the RS sport seats, front. Finished with the RS performance design package as an option in Alcantara/leather combination in black and with blue honeycomb pattern. Includes the blue decorative stitching on the controls, the centre console and the door armrests. This exclusive design idiom is also reflected consummately on the exterior: from the optionally available Ascari blue metallic paint finish to the striking exterior features such as the side flaps, the trim strips or the upper edge of the rear diffuser. Everything impresses in matt titanium look. Just like the 21-inch cast aluminium wheels in the 5-twin-arm design with gloss turned finish¹. Attributes that leave you in absolutely no doubt: this athlete is an aesthete.

The figures for fuel consumption and CO₂ emissions can be found on page 49.



¹Please note the special information relating to wheels on page 49.

This product catalogue features vehicles that may not be available in all countries. Please contact your Audi partner for details.

Model	R8 Coupé V10 plus	R8 Coupé V10	R8 Spyder V10
Engine type	V10 petrol engine with combined inlet manifold and direct fuel injection	V10 petrol engine with combined inlet manifold and direct fuel injection	V10 petrol engine with combined inlet manifold and direct fuel injection
Displacement in cc (valves per cylinder)	5,204 (4)	5,204 (4)	5,204 (4)
Max. output ¹ in kW at rpm	449/8,250	397/7,800	397/7,800
Max. torque in Nm at rpm	560/6,500	540/6,500	540/6,500
Power transmission			
Drive type	quattro permanent all-wheel drive	quattro permanent all-wheel drive	quattro permanent all-wheel drive
Transmission type	7-speed S tronic	7-speed S tronic	7-speed S tronic
Weights/capacities			
Unladen weight ² in kg	1,655	1,715	1,795
Gross vehicle weight in kg	1,920	1,940	2,020
Permissible roof load limit/nose weight in kg	-	-	-
Fuel tank capacity, approx. in l	73	83	80
Performance/consumption³			
Top speed in km/h	330	320	318
Acceleration 0–100 km/h in s	3.2	3.5	3.6
Fuel grade	Sulphur-free SuperPlus RON 98 ⁵	Sulphur-free SuperPlus RON 98 ⁵	Sulphur-free SuperPlus RON 98 ⁵
Fuel consumption ^{6,7} in l/100 km			
urban	17.5	16.7	17.0
extra-urban	9.3	8.4	8.7
combined	12.3	11.4	11.7
CO ₂ emissions ^{6,7} in g/km			
combined	287	272	277
Emission standard	EU6	EU6	EU6

TTRS Coupé	TTRS Roadster	RS 3 Sportback	RS 3 Saloon
5-cylinder inline petrol engine with combined inlet manifold and direct fuel injection, turbocharging with intercooling	5-cylinder inline petrol engine with combined inlet manifold and direct fuel injection, turbocharging with intercooling	5-cylinder inline petrol engine with combined inlet manifold and direct fuel injection, turbocharging with intercooling	5-cylinder inline petrol engine with combined inlet manifold and direct fuel injection, turbocharging with intercooling
2,480 (4)	2,480 (4)	2,480 (4)	2,480 (4)
294/5,850–7,000	294/5,850–7,000	294/5,850–7,000	294/5,850–7,000
480/1,700–5,850	480/1,700–5,850	480/1,700–5,850	480/1,700–5,850
Power transmission			
quattro permanent all-wheel drive	quattro permanent all-wheel drive	quattro permanent all-wheel drive	quattro permanent all-wheel drive
7-speed S tronic	7-speed S tronic	7-speed S tronic	7-speed S tronic
Weights/capacities			
1,515	1,605	1,585	1,590
1,840	1,850	2,010	2,005
75	-	75	75
55	55	55	55
Performance/consumption³			
250 ⁴ , optional: 280 ⁴	250 ⁴ , optional: 280 ⁴	250 ⁴ , optional: 280 ⁴	250 ⁴ , optional: 280 ⁴
3.7	3.9	4.1	4.1
Sulphur-free SuperPlus RON 98 ⁵	Sulphur-free SuperPlus RON 98 ⁵	Sulphur-free SuperPlus RON 98 ⁵	Sulphur-free SuperPlus RON 98 ⁵
Fuel consumption ^{6,7} in l/100 km			
urban	11.4–11.3	11.4–11.3	11.4–11.3
extra-urban	6.6–6.4	6.8–6.5	6.7–6.6
combined	8.4–8.2	8.5–8.3	8.4–8.3
CO ₂ emissions ^{6,7} in g/km			
combined	192–187	194–189	192–189
Emission standard	EU6	EU6	EU6

Model	RS 5 Coupé	RS 6 Avant	RS 6 Avant performance
Engine type	V6 petrol engine with direct fuel injection, turbocharging and Audi valvelift system	V8 petrol engine with direct fuel injection and turbocharging	V8 petrol engine with direct fuel injection and turbocharging with overboost function
Displacement in cc (valves per cylinder)	2,894 (4)	3,993 (4)	3,993 (4)
Max. output ¹ in kW at rpm	331/5,700–6,700	412/5,700–6,600	445/6,100–6,800
Max. torque in Nm at rpm	600/1,900–5,000	700/1,750–5,500	700/1,750–6,000
Max. torque with overboost in Nm at rpm	-	-	750/2,500–5,500
Power transmission			
Drive type	quattro permanent all-wheel drive	quattro permanent all-wheel drive	quattro permanent all-wheel drive
Transmission type	8-speed tiptronic	8-speed tiptronic	8-speed tiptronic
Weights/capacities			
Unladen weight ² in kg	1,730	2,025	2,025
Gross vehicle weight in kg	2,195	2,580	2,580
Permissible roof load limit/nose weight in kg	75/-	100/85	100/85
Trailer load limit ⁸ in kg			
unbraked	-	750	750
12 % gradient	-	2,100	2,100
8 % gradient	-	2,100	2,100
Fuel tank capacity, approx. in l	58	65	65
Performance/consumption³			
Top speed in km/h	250 ⁴ , optional: 280 ⁴	250 ⁴ , optional: 280 ⁴ , 305 ⁴	250 ⁴ , optional: 280 ⁴ , 305 ⁴
Acceleration 0–100 km/h in s	3.9	3.9	3.7
Fuel grade	Sulphur-free SuperPlus RON 98 ⁵	Sulphur-free SuperPlus RON 98 ⁵	Sulphur-free SuperPlus RON 98 ⁵
Fuel consumption ^{6,7} in l/100 km			
urban	11.5	13.4	13.4
extra-urban	7.1	7.4	7.4
combined	8.7	9.6	9.6
CO ₂ emissions ^{6,7} in g/km			
combined	197	223	223
Emission standard	EU6	EU6	EU6

RS 7 Sportback	RS 7 Sportback performance
V8 petrol engine with direct fuel injection and turbocharging	V8 petrol engine with direct fuel injection and turbocharging with overboost function
3,993 (4)	3,993 (4)
412/5,700–6,600	445/6,100–6,800
700/1,750–5,500	700/1,750–6,000
-	750/2,500–5,500
Power transmission	
quattro permanent all-wheel drive	quattro permanent all-wheel drive
8-speed tiptronic	8-speed tiptronic
Weights/capacities	
2,005	2,005
2,515	2,515
100	100
-	-
-	-
-	-
65	65
Performance/consumption³	
250 ⁴ , optional: 280 ⁴ , 305 ⁴	250 ⁴ , optional: 280 ⁴ , 305 ⁴
3.9	3.7
Sulphur-free SuperPlus RON 98 ⁵	Sulphur-free SuperPlus RON 98 ⁵
13.3	13.3
7.3	7.3
9.5	9.5
221	221
EU6	EU6

Explanatory notes

¹ The figure given was calculated using the specified measuring procedure (current version of UN-R 85).

² Unladen vehicle weight includes driver (75 kg) and fuel tank 90 % full, calculated in accordance with the current version of Reg. (EU) 1230/2012. Optional equipment may increase the car's unladen weight and drag coefficient, whereupon the possible payload limit and the top speed will be reduced accordingly.

³ Fuel consumption and CO₂ emission figures given in ranges depend on the tyre/wheel sets used.

⁴ Electronically regulated.

⁵ We recommend using sulphur-free SuperPlus unleaded RON 98 fuel complying with DIN EN 228. If this is not available, use sulphur-free super unleaded RON 95 fuel complying with DIN EN 228; power output will be slightly reduced. Unleaded RON 95 fuel with a maximum ethanol content of 10 % (E10) can generally be used. Fuel consumption details refer to operation with RON 95 fuel complying with 692/2008/EC.

⁶ The figures given were calculated using the specified measuring procedures. The figures do not refer to one individual vehicle and do not form part of any offer, but rather should be used purely for purposes of comparison between the different vehicle models.

⁷ A vehicle's fuel consumption and CO₂ emissions do not just depend on how efficiently the vehicle uses the fuel, but are also influenced by driving behaviour and other non-technical factors. CO₂ is the greenhouse gas primarily responsible for global warming.

⁸ The engine's power output always decreases with increasing altitude. At 1,000 m above sea level, and for every additional 1,000 m, deduct 10 % from the weight of the outfit (trailer load limit + gross weight of the towing vehicle). Figure for trailer load limit applies to factory-fitted trailer towing hitch. If using the vehicle with a trailer towing hitch for commercial purposes, a digital tachograph may be required under certain conditions.

Important note

Special information about the wheels: Wheels with gloss turned and gloss milled finish as well as polished or partly polished aluminium wheels must not be used in wintry road conditions. For manufacturing reasons, these wheel surfaces do not have sufficient corrosion protection for such use and they can be damaged permanently by road salt or similar.

Sporty driving: Models from Audi Sport GmbH are developed and produced for driving on public roads. Compared to normal road use, vehicles are put under significantly more stress than when used on racetracks or other closed circuits (e. g. during driver training, driving courses, track days). In particular, this applies to the engine, transmission, clutch and drivetrain as well as the suspension, brake system and tyres, which can result in greater wear. Special information about driving the vehicle on racetracks or other closed circuits is available in the on-board literature or from your Audi partner.

Audi R8 Coupé V10/Audi R8 Coupé V10 plus

Dimensions in mm

Dimensions are for unladen vehicle weight. Luggage capacity¹ 112 l, additional luggage capacity¹ behind driver and front-passenger seat 226 l. Turning circle approximately 11.2 m.
*Maximum headroom. **Elbow room width. ***Shoulder room width.

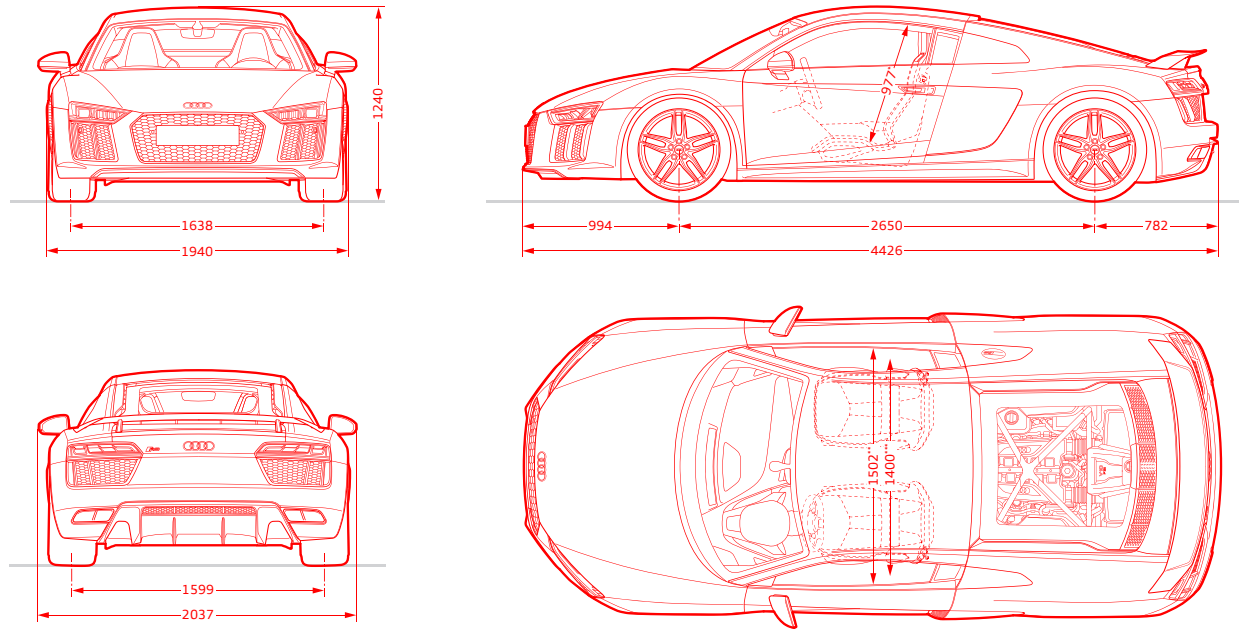

Audi R8 V10 Spyder

Dimensions in mm

Dimensions are for unladen vehicle weight. Luggage capacity¹ 112 l. Turning circle approximately 11.2 m.
*Maximum headroom. **Elbow room width. ***Shoulder room width.

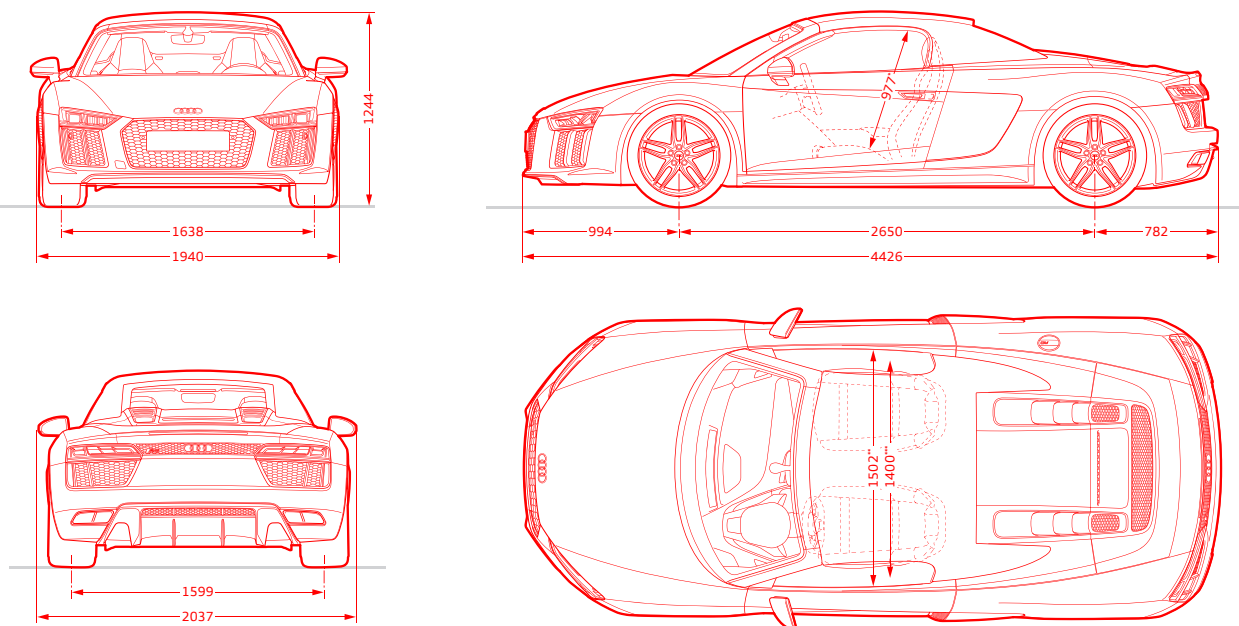

Audi TTRS Coupé

Dimensions in mm

Dimensions are for unladen vehicle weight. Luggage capacity¹ 305/712 l (second value is with the rear seat folded down and the vehicle loaded up to roof height). Turning circle approximately 10.96 m.
*Maximum headroom. **Elbow room width. ***Shoulder room width.

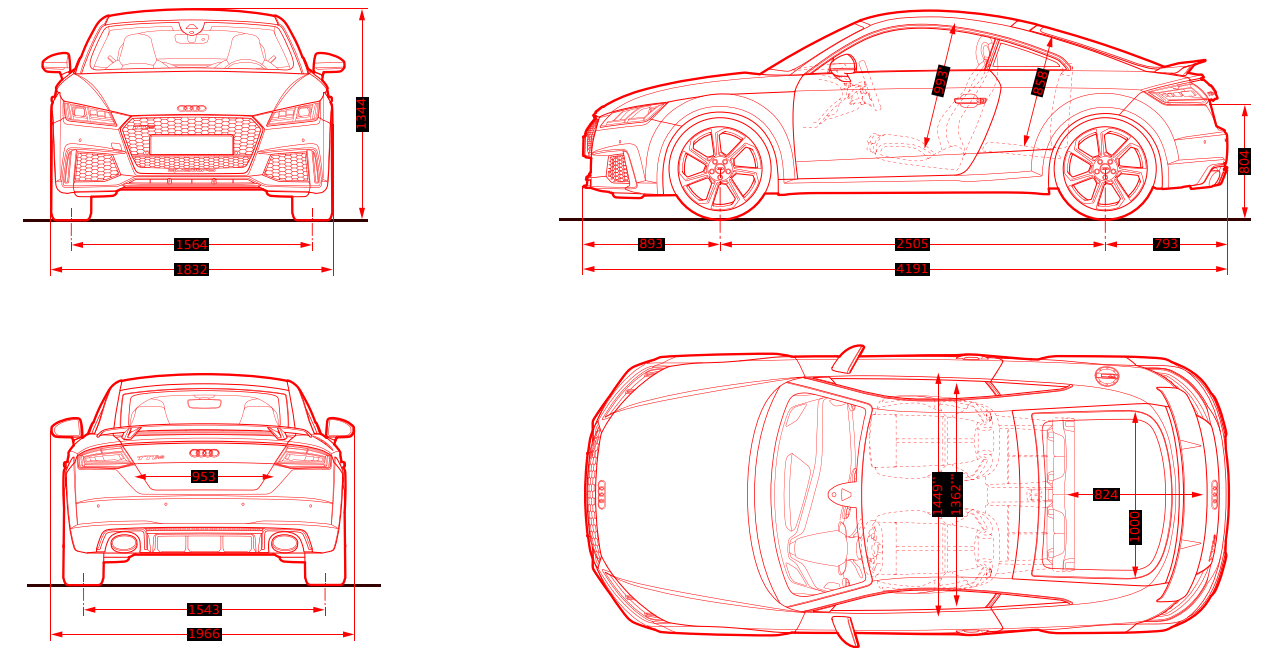

Audi TTRS Roadster

Dimensions in mm

Dimensions are for unladen vehicle weight. Luggage capacity¹ 280 l. Turning circle approximately 10.96 m.
*Maximum headroom. **Elbow room width. ***Shoulder room width.

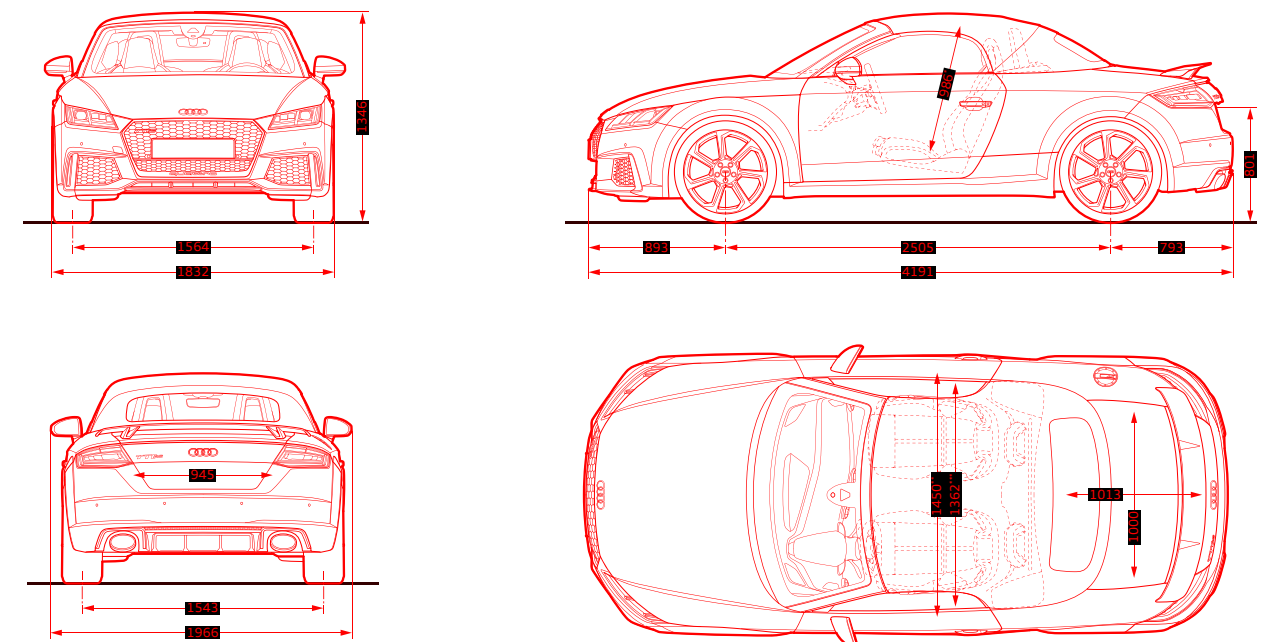

Audi RS3 Sportback

Dimensions in mm

Dimensions are for unladen vehicle weight. Luggage capacity¹ 335/1,175 l (second value is with the rear seat folded down and the vehicle loaded up to roof height). Turning circle approximately 11.0 m.
*Maximum headroom. **Elbow room width. ***Shoulder room width.

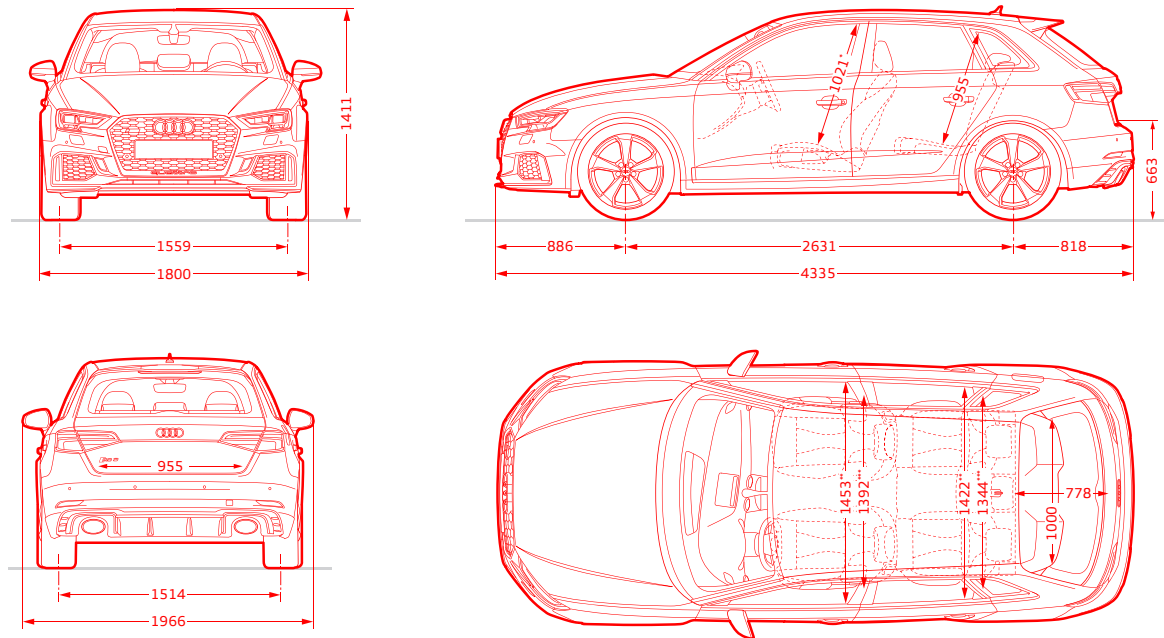

Audi RS3 Saloon

Dimensions in mm

Dimensions are for unladen vehicle weight. Luggage capacity¹ 315/770 l (second value is with the rear seat backrest folded down and vehicle loaded up to the rear parcel shelf). Turning circle approximately 11.0 m.
*Maximum headroom. **Elbow room width. ***Shoulder room width.

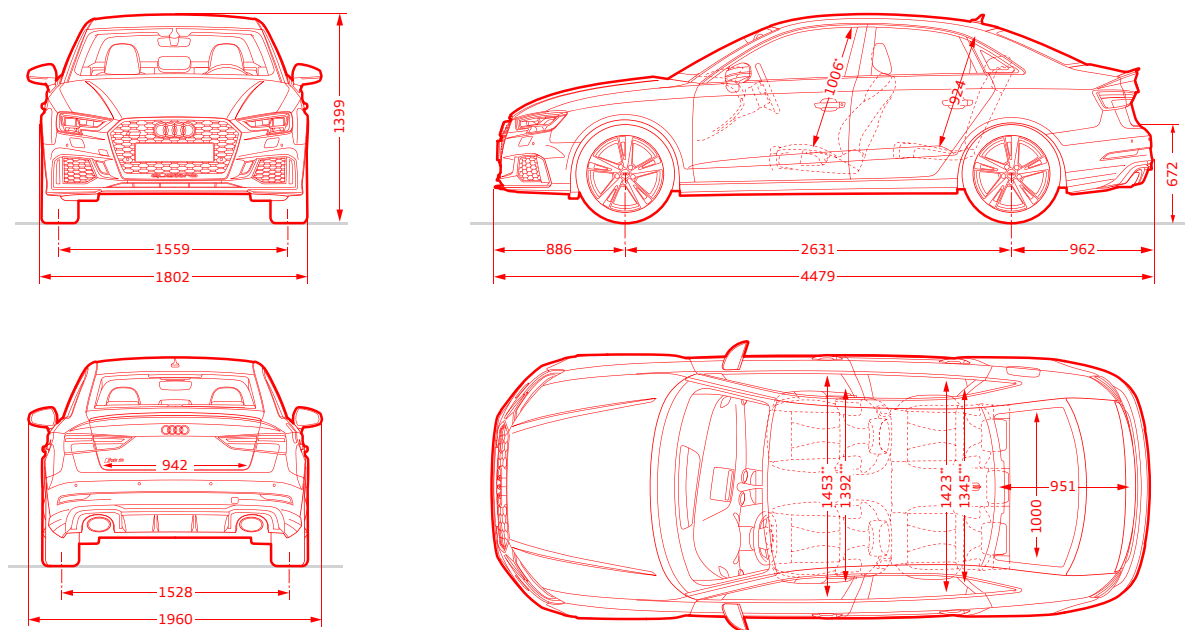

Audi RS5 Coupé

Dimensions in mm

Dimensions are for unladen vehicle weight. Luggage capacity¹ 465 l. Turning circle approximately 11.7 m.
*Maximum headroom. **Elbow room width. ***Shoulder room width.

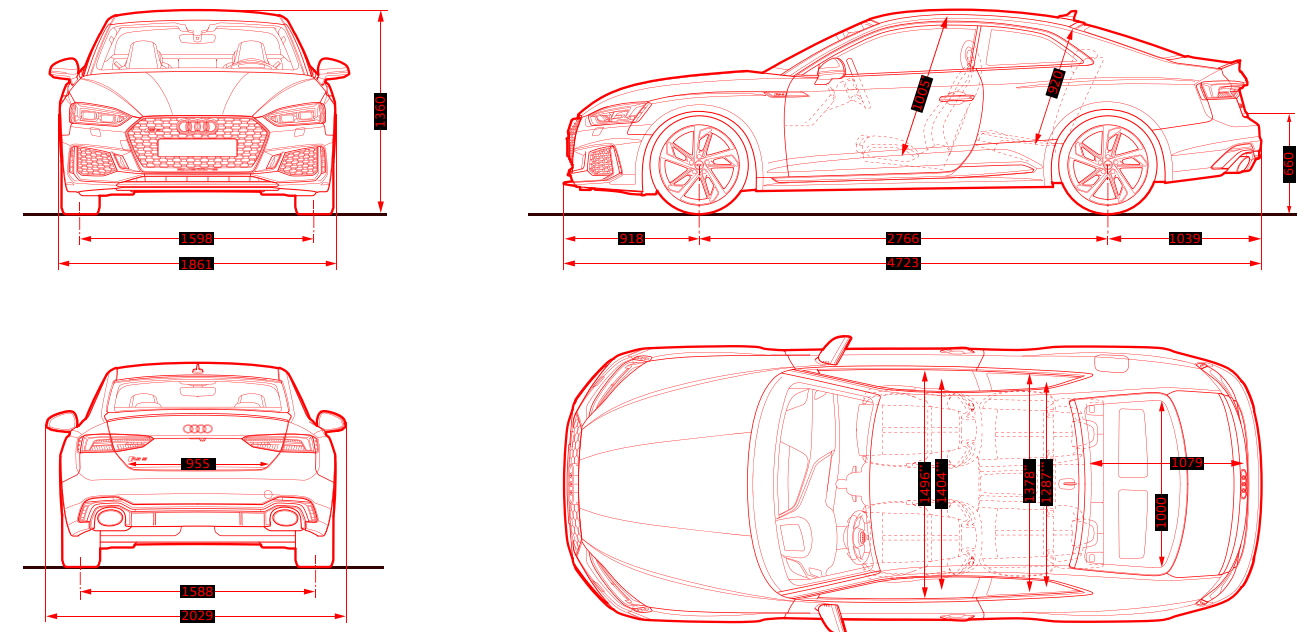

Audi RS6 Avant/Audi RS6 Avant performance

Dimensions in mm

Dimensions are for unladen vehicle weight. Luggage capacity¹ 565/1,680 l (second value is with the rear seat folded down and the vehicle loaded up to roof height). Turning circle approximately 11.9 m.
*With roof aerial the height of the vehicle is 1,482 mm. **Maximum headroom. ***Elbow room width. ****Shoulder room width.

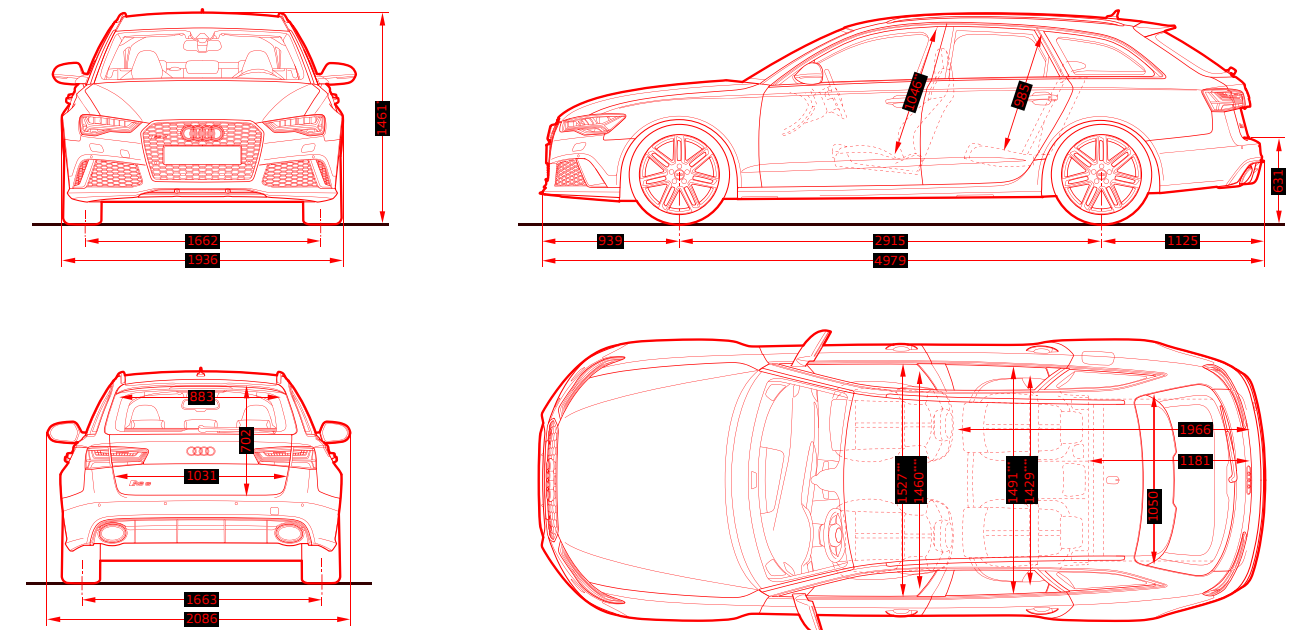

Audi RS 7 Sportback/Audi RS 7 Sportback performance

Dimensions in mm

Dimensions are for unladen vehicle weight. Luggage capacity¹ 535/1,390 l (second value is with the rear seat backrest folded down and vehicle loaded up to roof height). Turning circle approximately 11.9 m.

*Maximum headroom. **Elbow room width. ***Shoulder room width.

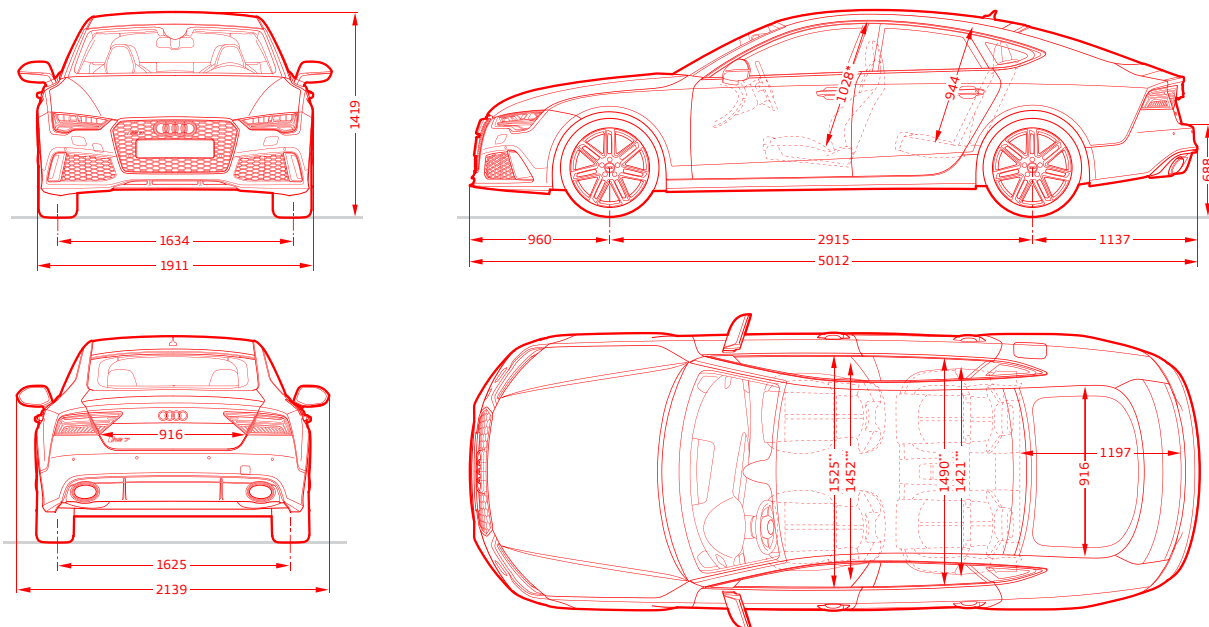

Classifications of tyre parameters

The table shows the range of fuel efficiency, wet grip and exterior noise emission classes for the different tyre sizes of the Audi Sport models shown below.

	Tyre size	Fuel efficiency class	Wet grip class	Exterior noise emission class
Summer tyres				
Audi RS 3	235/35 R 19	E	A	72
	255/30 R 19	E	A	73
Audi TTRS	245/35 R 19	E	B-A	72-70
	255/30 R 20	E	A	73
Audi RS 5	265/35 R 19	E	A	73-71
	275/30 R 20	E	A	73-71
Audi RS 6	275/35 R 20	E	A	73
	285/30 R 21	F-E	C-A	75-71
Audi RS 7	275/35 R 20	E	A	73
	275/30 R 21	F-E	B-A	73-70
Audi R8	245/35 R 19 front	E	A	72-67
	295/35 R 19 rear	E-C	A	75-68
	245/30 R 20 front	E	A	71
	305/30 R 20 rear	E	A	72
Sport tyres				
Audi R8 Coupé	245/30 R 20 front	E	C	70
	305/30 R 20 rear	E	C	73
Winter tyres				
Audi RS 3	235/35 R 19	E	B	72
Audi TTRS	225/40 R 19	E	B	72
	245/35 R 19	E	C	72
Audi RS 5	235/40 R 19	E	C	73
	275/30 R 20	E-C	C	73
Audi RS 6	245/40 R 20	E	C	73
	285/30 R 21	C	C-B	75-73
Audi RS 7	245/40 R 20	E	C	73
	275/30 R 21	C	C	72
Audi R8	245/30 R 20 front	E	C	72
	295/30 R 20 rear	E	C	75

It is not possible to order a specific tyre. Ask your Audi partner about the range of tyres available in your country.

The figures for fuel consumption and CO₂ emissions can be found from page 46 onwards.

¹Technical specifications refer to a basic vehicle without country-specific features and the selected optional equipment.

Audi R8

Equipment for the Audi R8 Coupé V10 plus illustrated (p. 6–9):

Paint finish: dynamite red with sideblades in gloss carbon

Wheels: 19-inch forged aluminium wheels in 5-twin-spoke design in matt titanium look, gloss turned finish¹

Seats/seat upholstery: R8 bucket seats in fine Nappa leather, rotor grey perforated with coloured stitching in dark silver

Inlays and extended inlays: gloss carbon

Equipment for the Audi R8 Coupé V10 illustrated (p. 10–13):

Paint finish: Daytona grey, pearl effect with sideblades in titanium grey, matt

Wheels: 20-inch forged aluminium wheels in 10-spoke Y design, gloss turned finish¹

Seats/seat upholstery: R8 sport seats in fine Nappa leather, Vermont brown with diamond pattern

Inlays: Audi exclusive piano finish look, black

Equipment for the Audi R8 Spyder V10 illustrated (p. 14–17):

Paint finish/hood: Vegas yellow with sideblades in gloss carbon/cloth, black

Wheels: 20-inch forged aluminium wheels in 10-spoke Y design in gloss anthracite black

Seats/seat upholstery: R8 sport seats in fine Nappa leather, black with diamond pattern and coloured stitching in Vegas yellow

Inlays and extended inlays: gloss carbon

Audi TTRS

Equipment for the Audi TTRS Coupé illustrated (p. 18–21):

Paint finish: Catalunya red, metallic

Wheels: 20-inch forged aluminium wheels in 7-spoke rotor design in gloss anthracite black, gloss turned finish¹

Seats/seat upholstery: RS sport seats, front in fine Nappa leather, black with coloured perforation and diamond pattern in dynamite red

Inlays: carbon

Other equipment: gloss black styling package, exterior mirror housings in carbon, RS sport exhaust system, RS design package, red

Equipment for the Audi TTRS Roadster illustrated (p. 22–25):

Paint finish/hood: Nardo grey/cloth, black

Wheels: 20-inch forged aluminium wheels in 7-spoke rotor design

Seats/seat upholstery:

Audi exclusive RS sport seats, front with design package, palomino brown

Inlays: carbon

Other equipment: matt aluminium styling package, RS design package, grey

Audi RS 3

Equipment for the Audi RS 3 Sportback illustrated (p. 26–29):

Paint finish: glacier white, metallic

Wheels: 19-inch cast aluminium wheels in 5-arm rotor design in gloss anthracite black, gloss turned finish¹

Seats/seat upholstery: RS sport seats, front in fine Nappa leather, black with coloured perforation and diamond pattern in dynamite red

Inlays: carbon

Other equipment: gloss black styling package, RS design package, RS sport exhaust system, ceramic brake

Equipment for the Audi RS 3 Saloon illustrated (p. 30–33):

Paint finish: mythos black, metallic

Wheels: 19-inch cast aluminium wheels in 5-arm blade design in gloss anthracite black, gloss turned finish¹

Seats/seat upholstery: RS sport seats, front in fine Nappa leather, lunar silver with coloured perforation and diamond pattern in granite grey

Inlays: Aluminium Race design light

Other equipment: matt aluminium styling package, brake callipers painted in gloss red

Audi RS 5

Equipment for the Audi RS 5 Coupé illustrated (p. 34–37):

Paint finish: Misano red, pearl effect

Wheels: 20-inch forged aluminium wheels in 5-arm trapezoidal design in gloss anthracite black, gloss turned finish¹

Seats/seat upholstery: RS sport seats, front in fine Nappa leather, black with honeycomb pattern in dynamite red

Inlays: carbon

Other equipment: carbon styling package including attachments in matt aluminium look, carbon roof, exterior mirror housings in carbon,

RS sport exhaust system, RS design package

Audi RS 6

Equipment for the Audi RS 6 Avant performance illustrated (p. 38–41):

Paint finish: Ascari blue, metallic

Wheels: 21-inch cast aluminium wheels in 5-V-spoke design in matt titanium look, gloss turned finish¹

Seats/seat upholstery: RS sport seats, front in Alcantara/leather combination, black with honeycomb pattern in blue

Inlays: carbon twill, blue

Audi RS 7

Equipment for the Audi RS 7 Sportback performance illustrated (p. 42–45):

Paint finish: Ascari blue, metallic

Wheels: 21-inch cast aluminium wheels in 5-twin-arm design in matt titanium look, gloss turned finish¹

Seats/seat upholstery: RS sport seats, front in Alcantara/leather combination, black with honeycomb pattern in blue

Inlays: carbon twill, blue

¹ Please note the special information relating to wheels on page 49.

*THAT'S WHY
WE DEVELOP
THE CARS WE DO.*

JOIN THE LEAGUE OF PERFORMANCE.

Audi Sport: Technologies from motor racing transferred to the road. Whether it's works motorsport, customer racing or our high-performance models – you'll not get such a potent adrenalin rush anywhere else. Audi Sport utilises the expertise gained in motor racing to bring innovative technologies to series production.

With unrivalled passion – for outstanding dynamism.

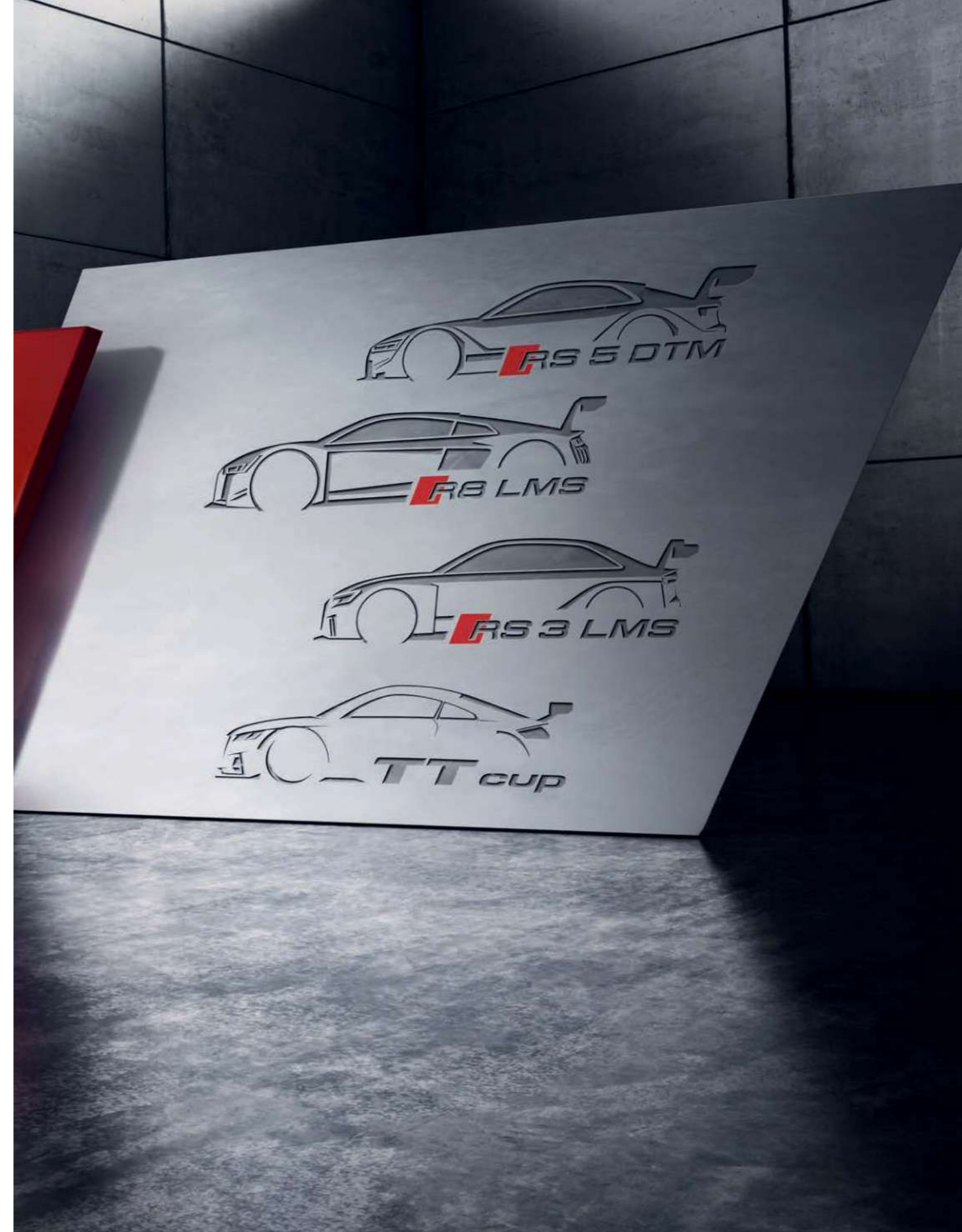

MAXIMUM
POWER.
PUT TO
MAXIMUM
USE.

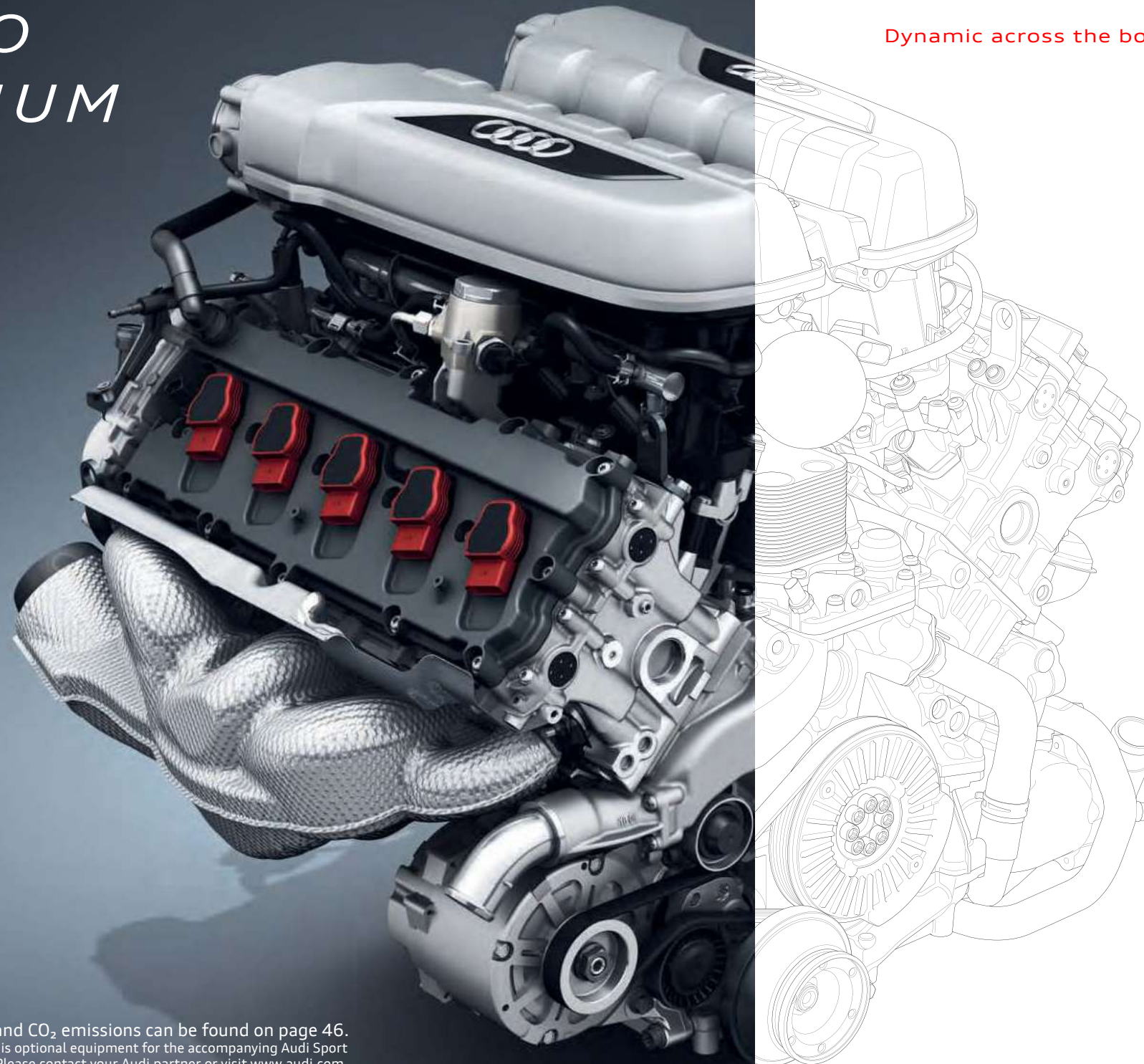

5.2 FSI V10 HIGH-REVVING ENGINE.

Dynamic across the board. The 5.2-litre V10 high-revving engine with dual injection produces 449 kW of power and maximum torque of 560 Nm, taking the R8 Coupé V10 plus from 0 to 100 km/h in just 3.2 seconds. Propulsion peaks at 330 km/h. The Audi R8 Coupé V10 and the Audi R8 Spyder V10 also bring similar power to the road. With 397 kW and 540 Nm, these two models race from 0 to 100 km/h in just 3.5 and 3.6 seconds respectively.

The deep installation position of the V10 engine and the cylinder angle of 90° lend the R8 its low centre of gravity. The dry sump lubrication, which is widely used in motor racing, ensures a reliable oil supply even under high lateral acceleration.

The combination of manifold and direct injection delivers a compelling mix of improved power delivery, low fuel consumption and reduced exhaust emissions. Depending on the driving conditions, Audi cylinder on demand delivers even better fuel consumption and emission figures in partial-load operation by switching off the injection and ignition for one cylinder bank.

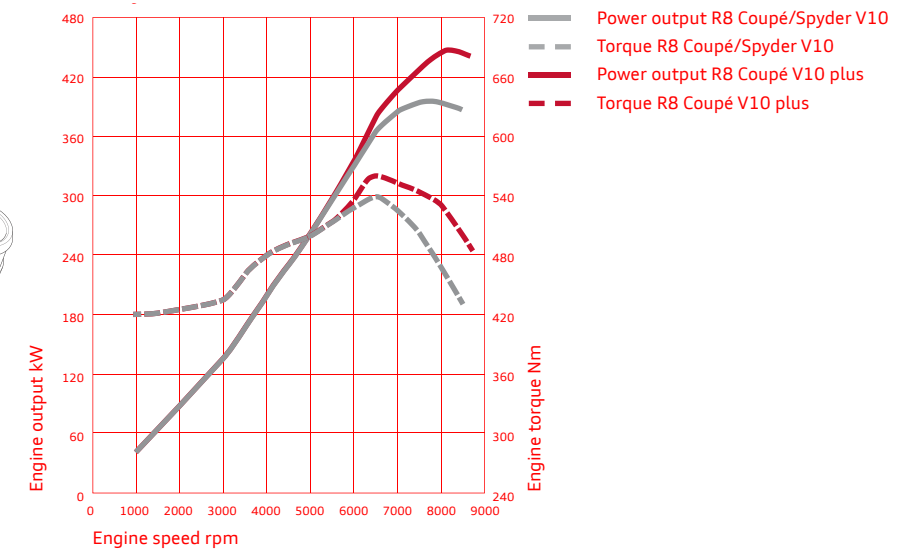

The figures for fuel consumption and CO₂ emissions can be found on page 46. Some of the equipment shown or described is optional equipment for the accompanying Audi Sport models for which an extra charge is made. Please contact your Audi partner or visit www.audi.com for detailed information about standard and optional equipment.

4.0 TFSI V8 BITURBO ENGINE.

Powerhouse.

In the Audi RS6 Avant and Audi RS7 Sportback, a 4.0 litre V8 TFSI engine with 412 kW and maximum torque of 700 Nm provides outstanding propulsive power. The engine comes with uprated values in the performance models. A power output of 445 kW and, temporarily, up to 750 Nm thanks to an overboost function enhance the driving dynamics.

Efficiency system: With Audi cylinder on demand only four of the eight cylinders are active in partial-load operation

depending on the driving conditions. The Audi valvelift system closes the intake and exhaust valves on two cylinders on each side and switches off their injection and ignition. The upshot is a notable improvement in fuel consumption and emission figures. The V8 TFSI also comes with a start-stop system and recuperation. And also excels with its spontaneous responsiveness and extraordinary power delivery over the entire engine speed range.

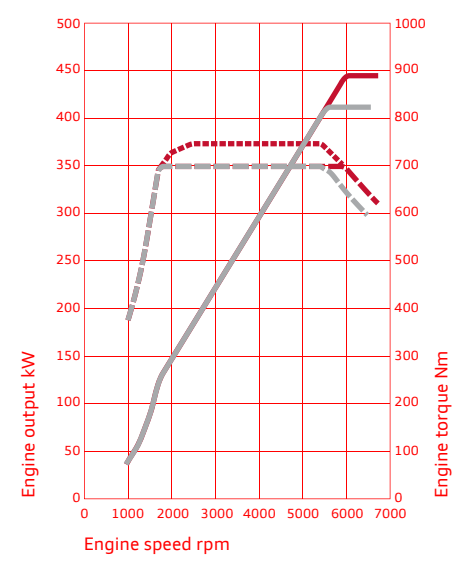

- Power output Audi RS6 Avant/ Audi RS7 Sportback
- - Torque Audi RS6 Avant/ Audi RS7 Sportback
- Power output Audi RS6 Avant performance/ Audi RS7 Sportback performance
- - Torque Audi RS6 Avant performance/ Audi RS7 Sportback performance
- - Torque with overboost Audi RS6 Avant performance/Audi RS7 Sportback performance

RS 6
RS 7



2.9 TFSI V6 BITURBO ENGINE.

Strong heart.

A 2.9-litre V6 TFSI engine is the driving power behind the Audi RS 5 Coupé. This engine is synonymous with superb performance, accentuated by a gratifying sound. Equipped with direct fuel injection, twin turbocharging and the Audi valvelift system, it combines impressive power, brawny torque and instant response with a large dose of

dose of efficiency. When it comes to the figures, you have 331 kW of power, 600 Nm of maximum torque with combined fuel consumption of 8.7 l/100 km. The sprint from 0 to 100 km/h takes a mere 3.9 seconds. As an option, the power can be electronically regulated at 280 km/h.

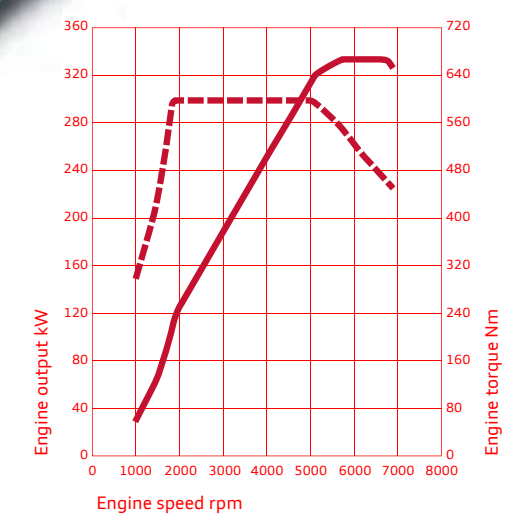

- Power output Audi RS5 Coupé
- - Torque Audi RS5 Coupé

The figures for fuel consumption and CO₂ emissions can be found from page 48 onwards. Some of the equipment shown or described is optional equipment for the accompanying Audi Sport models for which an extra charge is made. Please go to www.audi.com or visit your Audi partner for detailed information on standard and optional equipment.

RS 5

2.5 TFSI 5-CYLINDER INLINE TURBOCHARGED ENGINE.

The power from five cylinders: Only an exhilarating moment away. The turbocharged 2.5-litre 5-cylinder engine with dual injection and up to 1.35 bar of charge pressure produces up to 294 kW and 480 Nm. The typical rhythm can be heard immediately: 1-2-4-5-3. The extraordinary 5-cylinder basic design features an unmistakable sound thanks to the unique firing sequence, which can be adjusted by means of RS exhaust valve control. Compact dimensions, aluminium crankcase and numerous detailed design solutions reduce

the weight by 26 kg compared with its predecessor. And the engine is even more efficient despite the uprated power output. Experience instant responsiveness and impressive power delivery across the entire engine speed range. Despite all the sportiness, the efficiency is an equally compelling argument – thanks to the start-stop system and recuperation. The engine, recipient of the “International Engine of the Year Award”¹ for seven years running, boasts impressive power, torque and efficiency in combination with its hallmark sound.

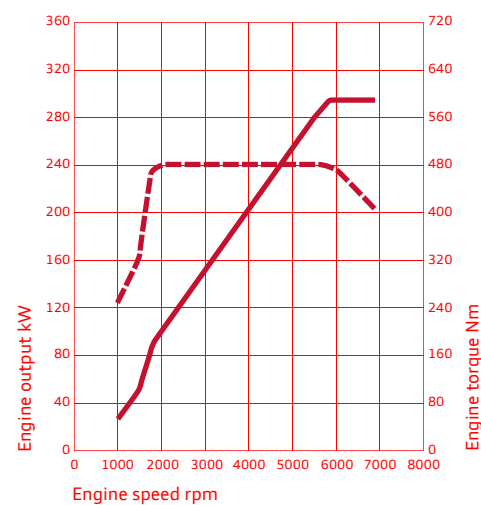

— Power output Audi TTRS/Audi RS 3
 - - - Torque Audi TTRS/Audi RS 3



The figures for fuel consumption and CO₂ emissions can be found on page 47.

Some of the equipment shown or described is optional equipment for the accompanying Audi Sport models for which an extra charge is made. Please go to www.audi.com or visit your Audi partner for detailed information on standard and optional equipment. ¹ Awarded in the “2-litre to 2.5-litre” category (www.ukipme.com/engineoftheyear).

TTRS
RS 3

CONTROL
CENTRE.

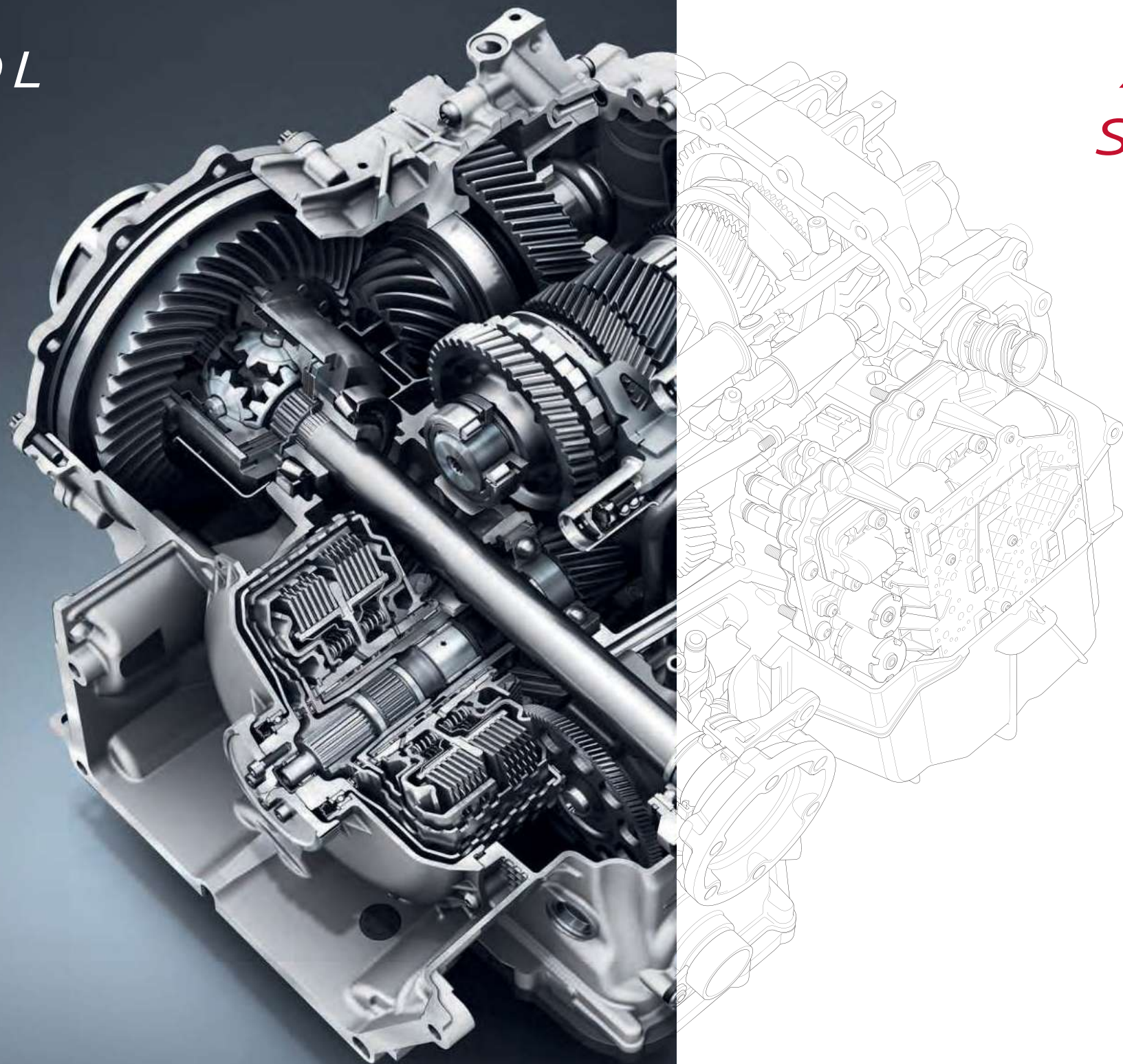

7-SPEED S TRONIC.

The 7-speed S tronic combines the advantages of a conventional manual transmission with those of a modern automatic transmission. Setting benchmarks in sportiness, comfort and efficiency.

The dual-clutch transmission comprises two component gearboxes and changes gear by switching the power-transmitting clutch. Gear changes are precise, lightning-fast and with virtually no break in propulsive power. The S tronic features the D (Drive) and S (Sport) programs in automatic mode. Manual mode offers additional driving enjoyment with the driver able to change gears actively via shift paddles on the steering wheel or by nudging the selector lever. At the same time, the high level of efficiency and the large ratio range promote efficient driving. On the Audi R8, a coasting mode also helps boost efficiency.

The figures for fuel consumption and CO₂ emissions can be found from page 46 onwards. Some of the equipment shown or described is optional equipment for the accompanying Audi Sport models for which an extra charge is made. Please go to www.audi.com or visit your Audi partner for detailed information on standard and optional equipment.

R8
TT RS
RS 3

8-SPEED TIPTRONIC.

The 8-speed tiptronic is a highly efficient torque converter automatic that delivers fast, instantaneous gear changes. Thanks to the eight gears, the shifts in engine speed between the gears are minimal; the engine always runs close to its ideal load point. The low gears are sportily short; the high gears feature long ratios that reduce engine speed and fuel consumption.

The Dynamic Shift Program (DSP) provides transmission control. In D (Drive) mode, the DSP prefers high gears and low engine speeds to promote an efficient driving style; the S (Sport) mode provides for a sportier driving style in automatic mode thanks to gear change points that are set later. Manual mode is available for enhanced driving enjoyment or targeted influencing of the engine speed, e. g. to augment the engine braking effect when negotiating downhill gradients. The engine commands are executed by paddles on the steering wheel or by nudging the selector lever.

In the Audi RS 5 Coupé, the tiptronic also features coasting mode to increase efficiency.

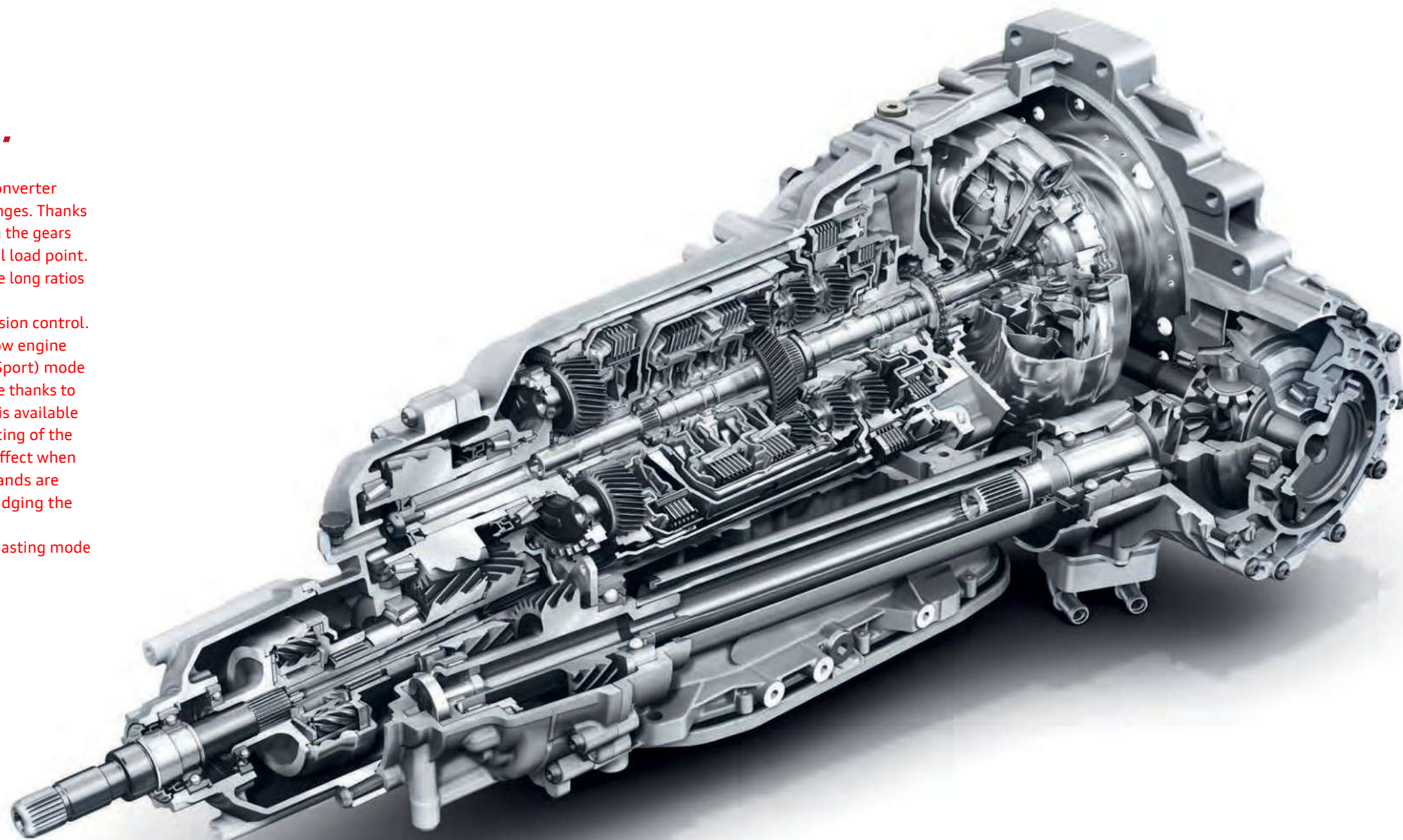

The figures for fuel consumption and CO₂ emissions can be found from page 48 onwards. Some of the equipment shown or described is optional equipment for the accompanying Audi Sport models for which an extra charge is made. Please go to www.audi.com or visit your Audi partner for detailed information on standard and optional equipment.

RS 5
RS 6
RS 7

GROUND CONTROL.

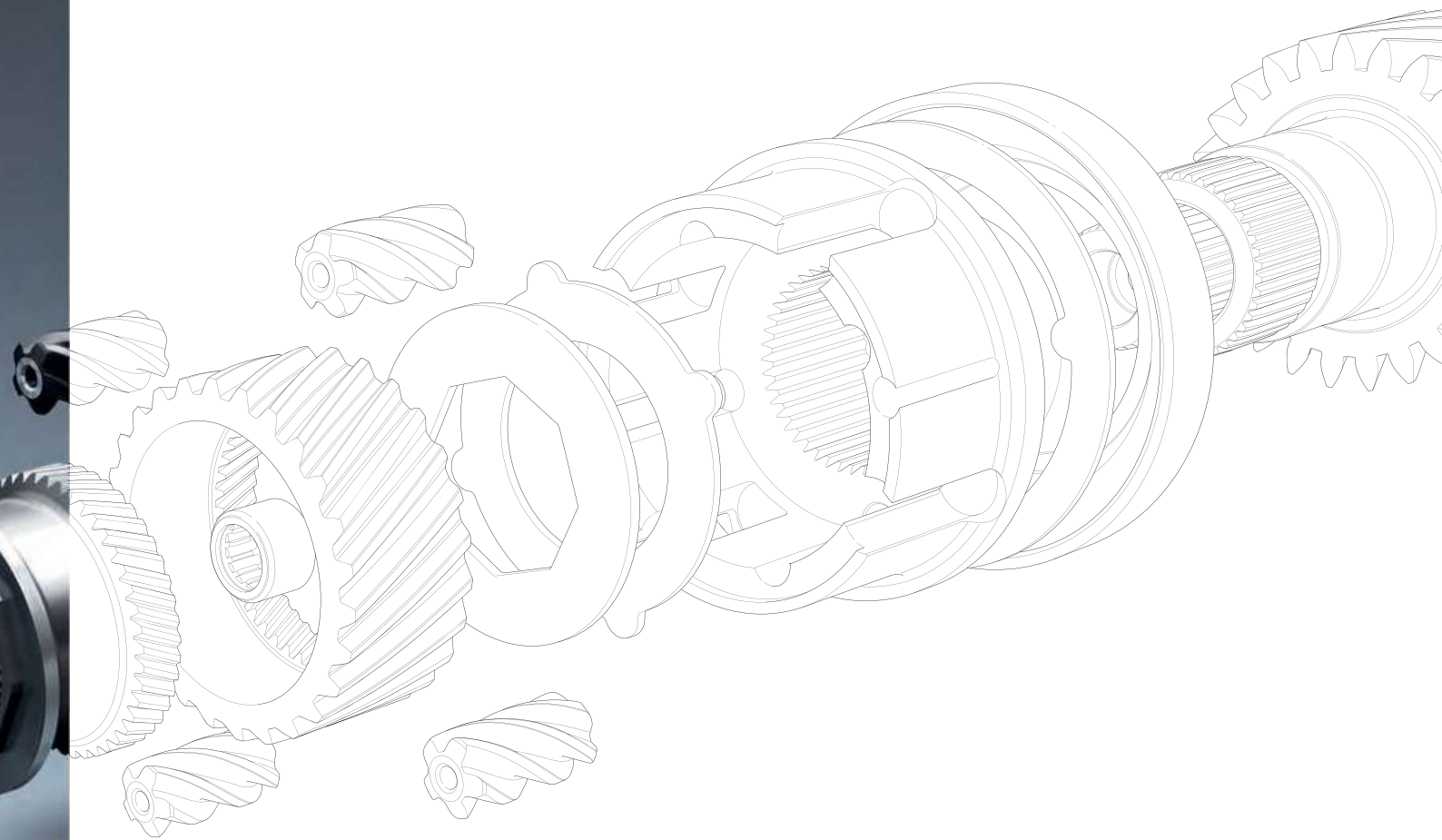
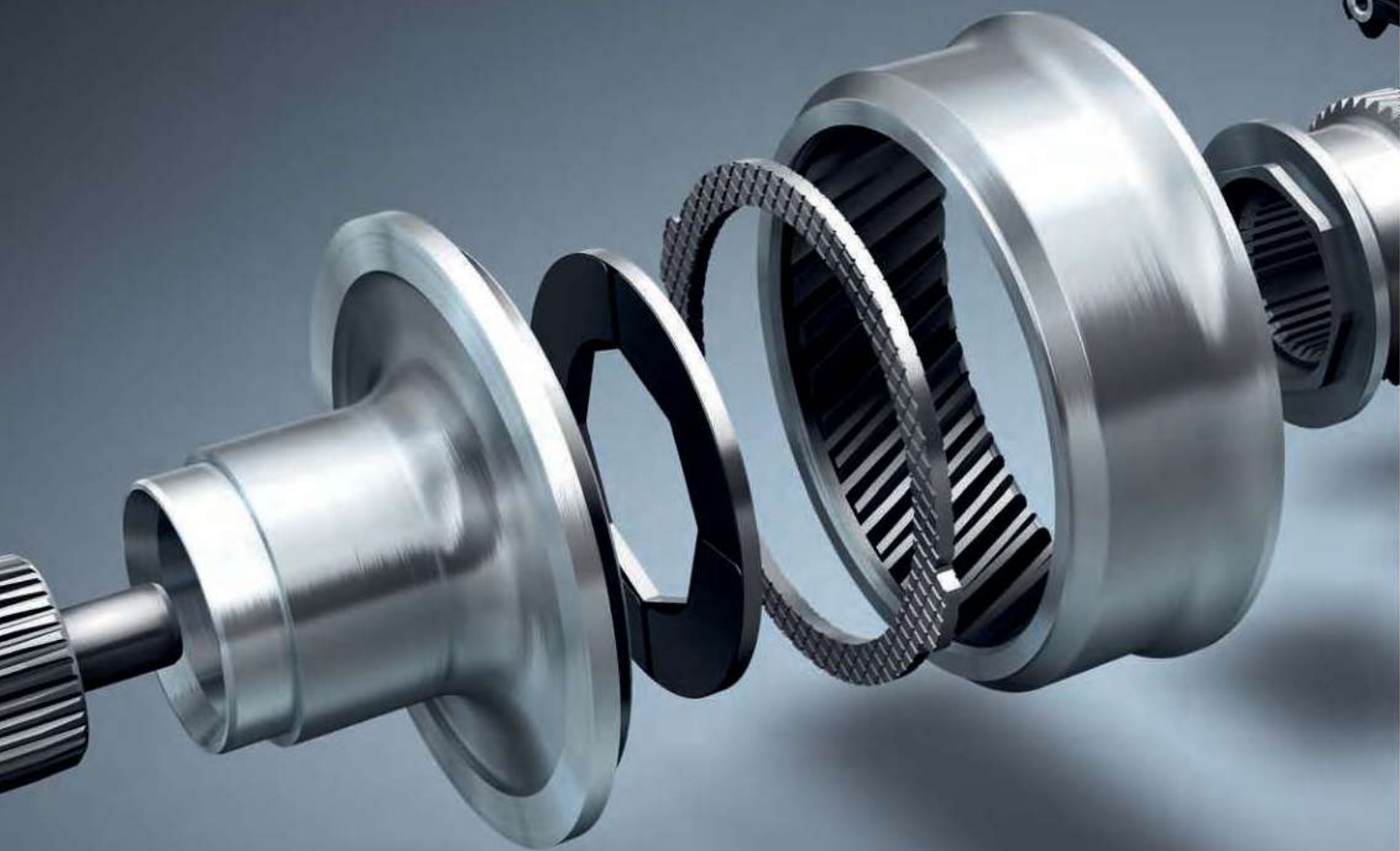

quattro.

With self-locking centre differential.

Outstanding traction, improved driving dynamics and more driving safety. Or quattro for short. Hardly any other drive system transfers the engine's power to the road so effortlessly. The central component is the self-locking centre differential. The basic configuration of the purely mechanical planetary gear set distributes the drive torque asymmetrically for better driving dynamics. In a ratio of 40:60 between the front and rear axles. But if necessary, up to 70 % can be distributed to the front or up to 85 % to the rear to offset any occurring wheel slip.

Using wheel-selective torque control, the drive force is distributed to each individual wheel depending on the driving situation. What is special here is the way the effects of the torque distribution are felt before any undesirable wheel slip occurs. The result is a yawing moment that supports cornering – and thus provides precisely controlled, sporty handling with increased agility and superb traction at the same time.

To take driving dynamics to an entirely new level, this quattro drivetrain can be supplemented by the sport differential on the rear axle as an option.

The figures for fuel consumption and CO₂ emissions can be found from page 48 onwards. Some of the equipment shown or described is optional equipment for the accompanying Audi Sport models for which an extra charge is made. Please go to www.audi.com or visit your Audi partner for detailed information on standard and optional equipment.

RS 5
RS 6
RS 7

quattro. With electrohydraulic multi-plate clutch.

Superb roadholding – thanks to the distribution of drive forces to the front and rear axles as required: that is quattro. An electronically controlled hydraulic multi-plate clutch is used in this engineering variant of the permanent all-wheel drive to distribute the power. In addition, the wheel-selective torque control counteracts undesirable wheel slip through targeted

braking actions on all wheels. The result is controlled and sporty driving behaviour while maintaining outstanding traction. In the Audi RS 3 and Audi TT RS, the multi-plate clutch is fitted to the rear axle. Audi drive select makes a rear-wheel drive bias possible for more driving enjoyment and enhanced agility.

Here's what is so special about the Audi R8: Due to the mid-engine layout, the multi-plate clutch is located at the front axle, supplemented by a mechanical locking differential at the rear axle. Depending on the weather and road conditions, it is possible to further modify the permanent all-wheel drive. By linking the quattro software

with Audi drive select, R8 Coupé V10 plus drivers are able to use performance mode to adjust the drive characteristics to the route conditions. The R8 Coupé V10 and the R8 Spyder V10 can also be equipped with performance mode as an option.

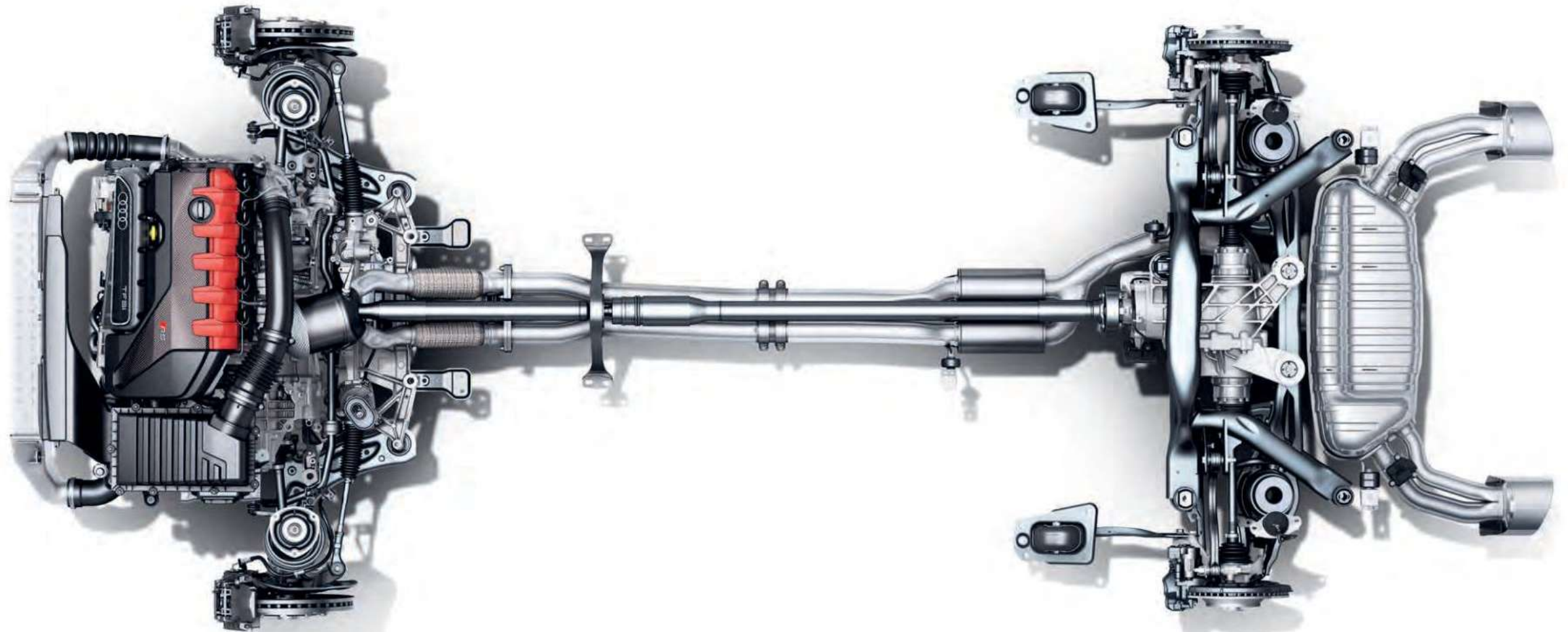

The figures for fuel consumption and CO₂ emissions can be found from page 46 onwards. Some of the equipment shown or described is optional equipment for the accompanying Audi Sport models for which an extra charge is made. Please go to www.audi.com or visit your Audi partner for detailed information on standard and optional equipment.

R8
TT RS
RS 3

BENDING THE ROAD TO YOUR WILL.

AUDI MAGNETIC RIDE.

The sport suspension in the Audi R8 allows you to experience sporty as well as self-assured driving. With its origins firmly rooted in motor racing, the design with its double-wishbone axle for the front and rear suspension delivers highly precise wheel location and excellent agility. And for individual suspension tuning, there is the optional Audi magnetic ride. Depending on the selected mode, the damping forces are adjusted to the corresponding driving situation in fractions of a second. Synthetic hydrocarbon oil, which contains microscopic magnetic particles, circulates in the shock absorber pistons. When a voltage is applied to a coil integrated in the shock absorber, a magnetic field is produced

that realigns the particles in a few milliseconds. Since they flow in the opposite direction to the oil, they restrict the flow of oil through the piston channels. The system's control unit continuously calculates the optimum values for each individual wheel on the basis of a wealth of sensor data. It analyses the driver's style and road conditions and adaptively adjusts the dampers' response – either for greater comfort or enhanced driving dynamics.

The adaptive shock absorber function is also available for the Audi RS 3 and the Audi TTRS by selecting the optional RS sport suspension plus with Audi magnetic ride.



The figures for fuel consumption and CO₂ emissions can be found from page 46 onwards. Some of the equipment shown or described is optional equipment for the accompanying Audi Sport models for which an extra charge is made. Please go to www.audi.com or visit your Audi partner for detailed information on standard and optional equipment.

R8
TTRS
RS 3

DYNAMIC RIDE CONTROL (DRC).

Show character. Self-assured, sporty. With the standard RS sport suspension in the Audi RS5 Coupé. In the Audi RS6 and RS7 models with adaptive air suspension as the RS adaptive air suspension. Experience outstanding directional stability, excellent agility and precise steering characteristics thanks to sophisticated suspension kinematics and specifically tuned spring/shock absorber combinations. And enhance sporty handling by choosing the optional RS sport suspension plus with Dynamic Ride Control (DRC). Steel springs and

shock absorbers with variable characteristics reduce the pitching and rolling movements around the lateral and longitudinal axes purely by hydraulic means. The diagonal dampers are connected to one another via oil pipes and one central valve each. If the dampers compress differently, for example during fast cornering, the valves regulate the oil flow to the deflected wheel. They increase support there, thus reducing side tilt and enhancing driving dynamics.

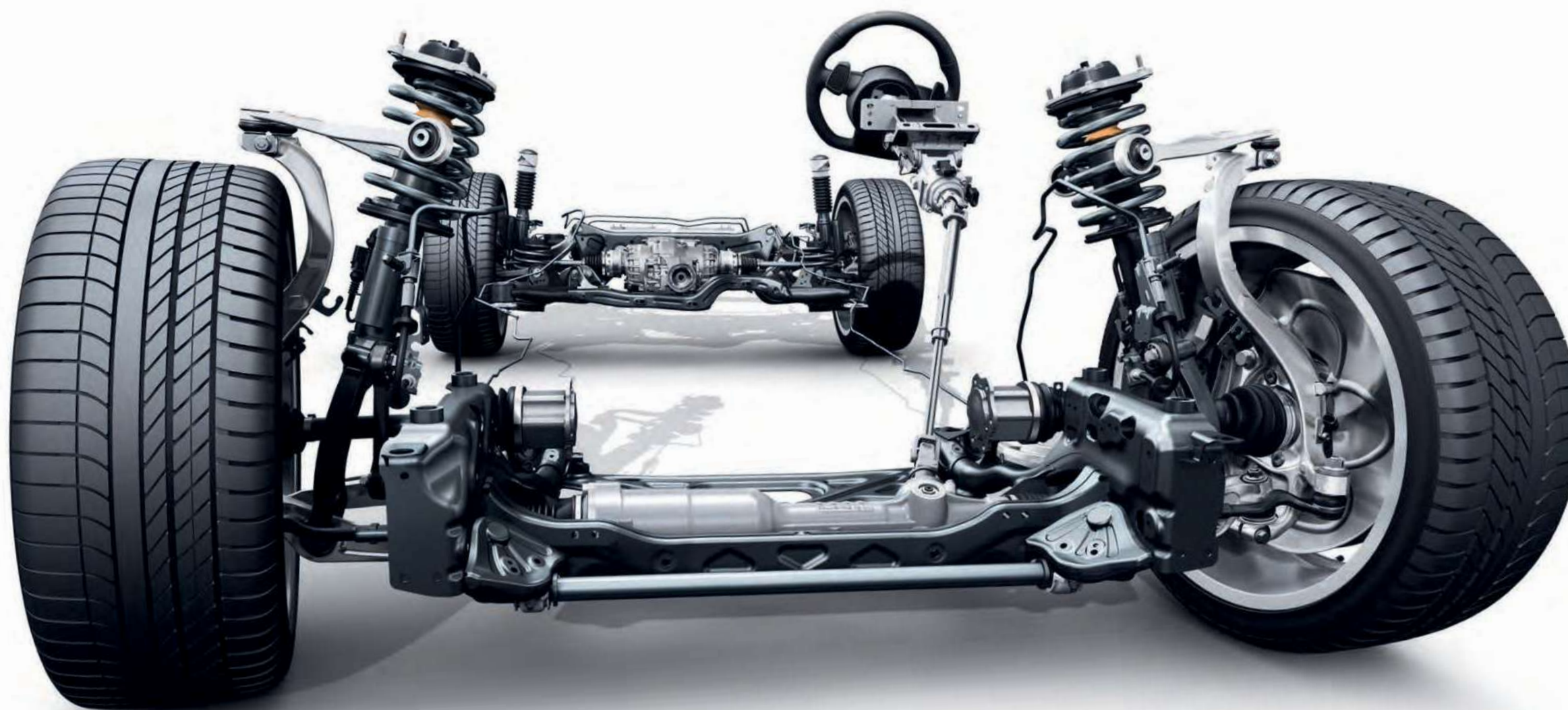

The figures for fuel consumption and CO₂ emissions can be found from page 48 onwards. Some of the equipment shown or described is optional equipment for the accompanying Audi Sport models for which an extra charge is made. Please go to www.audi.com or visit your Audi partner for detailed information on standard and optional equipment.

RS 5
RS 6
RS 7

*SUSTAINED
EXHILARATION.*

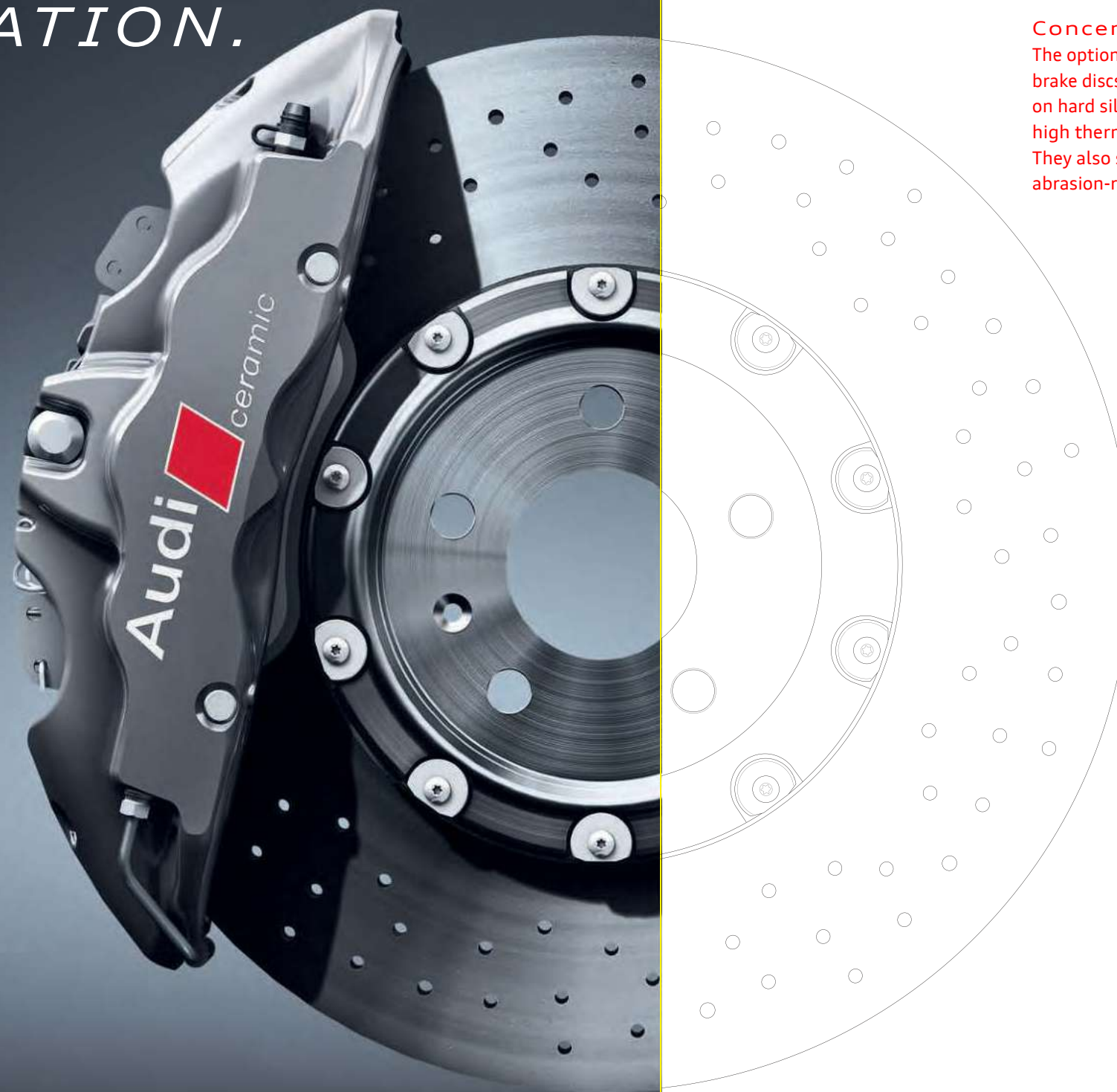

CERAMIC BRAKE.

Concentrated power, even when braking:
The optional ceramic brake was developed for more demanding loads. Featuring brake discs that are made of a carbon-fibre-reinforced ceramic material based on hard silicon carbide with embedded high-strength carbon fibres. Even under high thermal stress, their excellent deceleration and control are impressive. They also stand out thanks to their low weight. And the remarkably hard and abrasion-resistant material increases the service life of the discs.



The figures for fuel consumption and CO₂ emissions can be found from page 46 onwards.
Some of the equipment shown or described is optional equipment for the accompanying Audi Sport models for which an extra charge is made. Please go to www.audi.com or visit your Audi partner for detailed information on standard and optional equipment.

R8
TT RS
RS 3
RS 5
RS 6
RS 7

HIGH-PERFORMANCE BRAKE SYSTEMS

Demonstrate power.

With the standard high-performance brake systems. The 6- or 8-piston fixed callipers at the front take powerful hold of the ventilated and perforated steel discs, whose large cast friction ring is connected to the aluminium brake disc chamber. Known as a floating mounting, this ensures that the friction ring remains tension-free to a major extent, thus improving stability when subjected to high temperatures. Axial perforation and cooling channels for internal ventilation increase the performance of the brake discs. Their mix of materials helps reduce weight, thus improving the balance of the unsprung masses.



The figures for fuel consumption and CO₂ emissions can be found from page 46 onwards. Some of the equipment shown or described is optional equipment for the accompanying Audi Sport models for which an extra charge is made. Please go to www.audi.com or visit your Audi partner for detailed information on standard and optional equipment.

R8
TT RS
RS 3
RS 5
RS 6
RS 7

REACH YOUR
DESTINATION.
THE WAY
YOU WANT.



AUDI DRIVE SELECT.

Change character.

With the standard Audi drive select. Numerous vehicle components can be influenced at the push of a button to adapt them to the prevailing driving situation. Including the engine characteristics, the steering torque of the electromechanical power steering, the transmission mode and the exhaust flap control. Depending on the model, the power distribution of the quattro permanent all-wheel drive or the characteristics of the RS adaptive air suspension can also be modified. The driver has access to four different modes to change the vehicle's character:

auto, comfort, dynamic and individual. auto for superior sporty quality. comfort for longer journeys. dynamic for more ambitious driving. And individual to configure the separate components to your own preferences.

What's more, the Audi R8 Coupe V10 plus is equipped as standard with the performance mode, which is also optionally available for the R8 Coupé V10 and the R8 Spyder V10. Thanks to the permanently assigned frictional coefficient parameters dry, wet and snow, drivers are able to actively adjust the R8 to the corresponding route conditions.

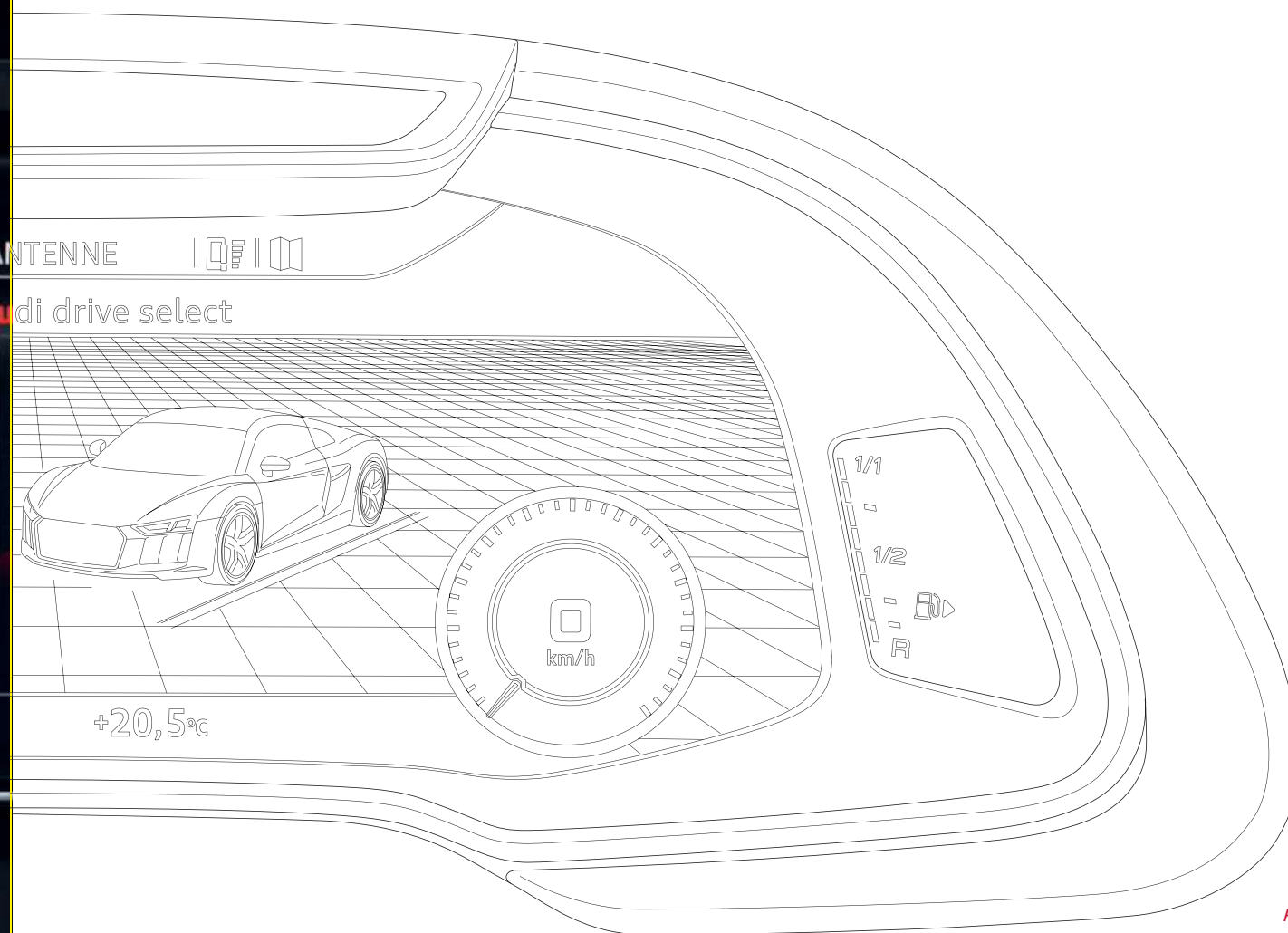

The figures for fuel consumption and CO₂ emissions can be found from page 46 onwards. Some of the equipment shown or described is optional equipment for the accompanying Audi Sport models for which an extra charge is made. Please go to www.audi.com or visit your Audi partner for detailed information on standard and optional equipment.

R8
TTRS
RS 3
RS 5
RS 6
RS 7

AUDI DRIVE SELECT.

Your attitude counts.

In addition to the standard vehicle components, Audi drive select allows you to adjust various optional systems – such as the characteristic curves of the shock absorbers on the optionally available sport suspensions with damper control such as the RS sport suspension plus with Dynamic Ride Control (DRC) or Audi magnetic ride. These can be varied in three stages: From balanced rolling in comfort mode through to sporty, direct responsiveness in the dynamic setting.

The optional dynamic steering can also be varied. The power steering assistance and ratio are changed depending on the driving speed and the Audi drive select mode chosen.

The optional quattro with sport differential also allows additional infinitely variable distribution of the drive forces between the rear wheels. This torque manipulation specifically influences the vehicle's steering behaviour and increases agility even further. How the optional adaptive cruise control responds can also be set to be either more gradual or more spontaneous.

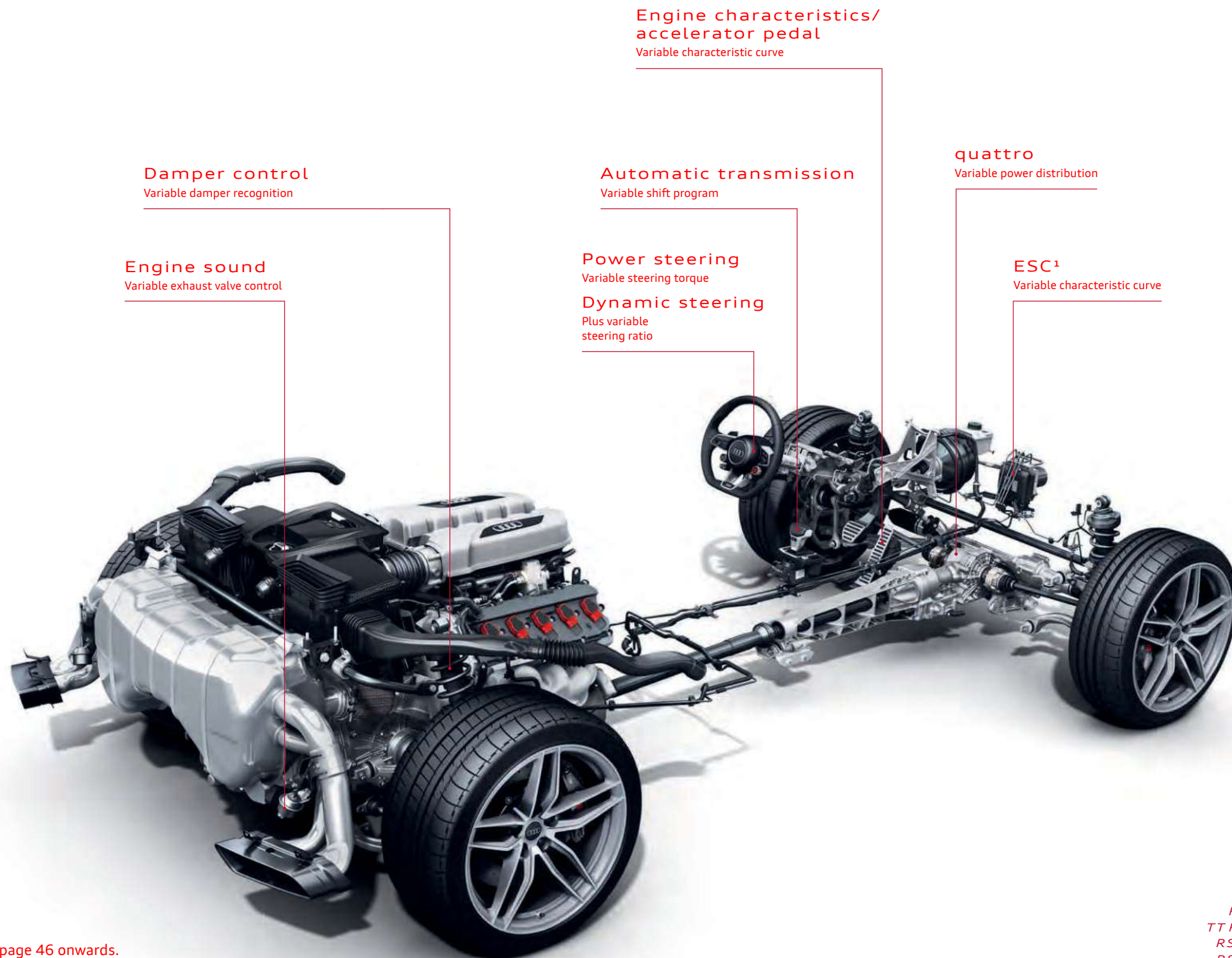

The figures for fuel consumption and CO₂ emissions can be found from page 46 onwards. Some of the equipment shown or described is optional equipment for the accompanying Audi Sport models for which an extra charge is made. Please go to www.audi.com or visit your Audi partner for detailed information on standard and optional equipment.

¹ Only in conjunction with performance mode.

*LESS
IS STRONGER.*



AUDI LIGHTWEIGHT DESIGN TECHNOLOGY.

Audi Space Frame (ASF)

Vehicle body rigidity made easy: For over two decades, the Audi Space Frame (ASF) has been a convincing example of innovative lightweight technology. The high-strength aluminium frame is characterised by high rigidity and low weight. For the R8 Coupe and the R8 Spyder, the body concept of the Audi Space Frame (ASF) was taken to the next evolutionary level. The multi-material construction design takes centre stage.

The figures for fuel consumption and CO₂ emissions can be found on page 46. Some of the equipment shown or described is optional equipment for the accompanying Audi Sport models for which an extra charge is made. Please go to www.audi.com or visit your Audi partner for detailed information on standard and optional equipment.

INNOVATIVE LIGHTWEIGHT DESIGN – AUDI SPACE FRAME (ASF).

The body of the Audi R8 Coupé is made up of a variety of components: 50 % extruded aluminium sections, 15 % aluminium sheets and 21 % aluminium cast nodes. In addition to the well-known materials, new materials are being used in the Audi R8 Coupé for the first time – such as the carbon elements that make up the final 14 %. In addition to 52 % extruded aluminium sections, 8 % aluminium sheets and 20 % aluminium cast nodes, the body of the Audi R8 Spyder V10 also has 12 % carbon elements. For instance, the hood compartment lid on the R8 Spyder is made of carbon-fibre-reinforced plastic. What this means for you: high levels of safety, enhanced performance and improved handling.

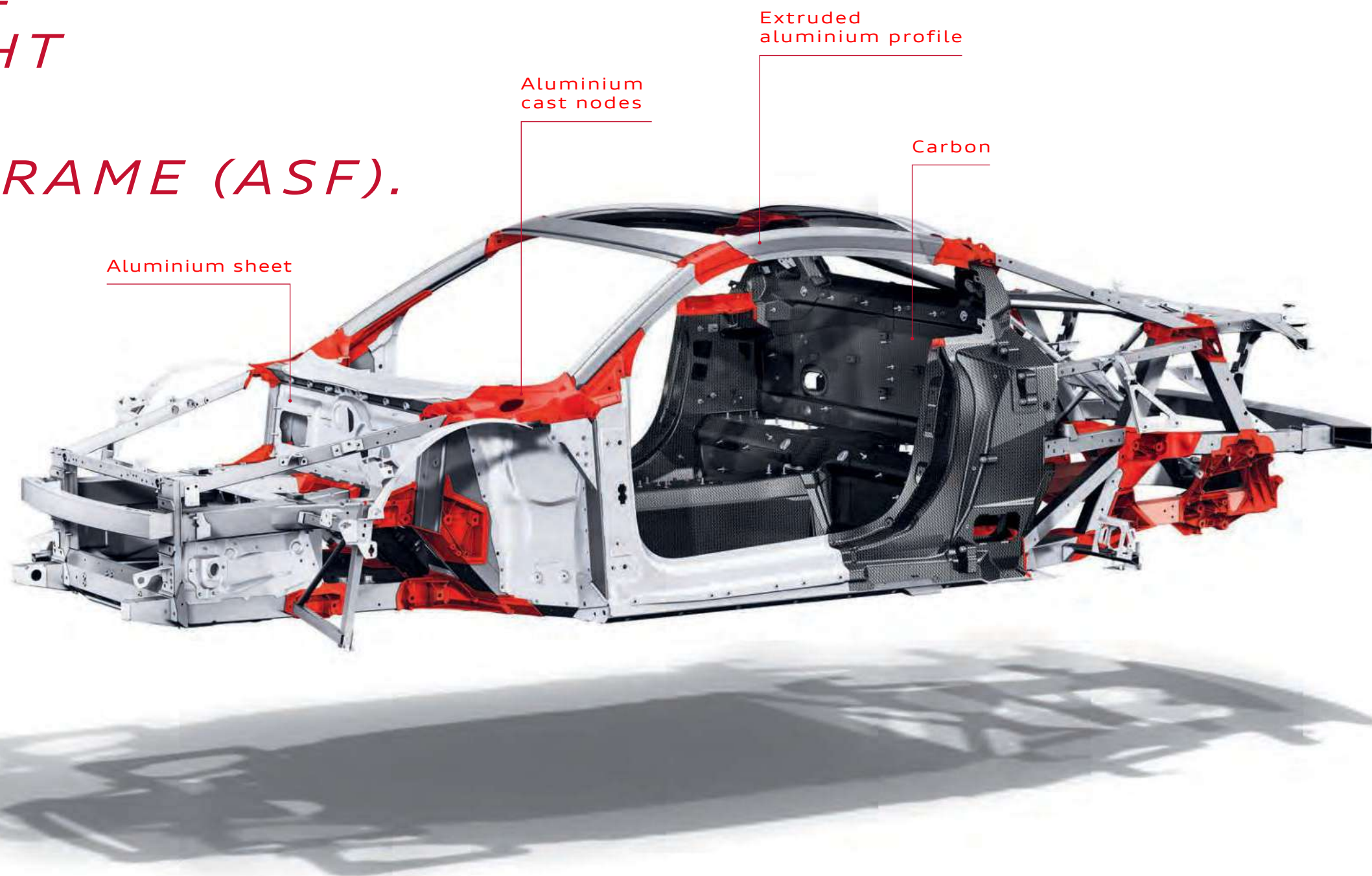

The figures for fuel consumption and CO₂ emissions can be found on page 46.
Some of the equipment shown or described is optional equipment for the accompanying Audi Sport models for which an extra charge is made.
Please go to www.audi.com or visit your Audi partner for detailed information on standard and optional equipment.

HIGH-QUALITY WORK DOWN TO THE LAST DETAIL.

Hand-crafted production of the Audi R8 sports car.



Each Audi R8 is unique, with its own, very personal signature. Unlike in large-scale production runs with fully automated processes, the R8 is mostly hand-made in the sports car manufacturing facility of Audi Sport GmbH. For example, bodyshell welds are performed mainly by hand. Robots merely aid non-ergonomic production methods. Small, highly qualified teams give the sports car its unique shape and

always comply with stringent Audi requirements – from assembling the body to adding the finishing touches. After completion of the bodyshell, the most experienced employees assemble the R8 almost entirely by hand at 15 coordinated stations. Due to the numerous equipment versions and customisation options, virtually no combination is created twice.



*AS UNIQUE AS
YOU ARE.* The equipment options.

Sportiness, comfort, design, functionality – whatever you demand from your Audi, it offers you a wealth of customisation options. Audi equipment versions are varied and high-quality and you can tailor them entirely to your needs.

YOUR AUDI IS PAINTED NOT JUST ONCE.

But several times.

Choose the paint finish to suit your individual taste. But whichever colour you opt for, you can count on the outstanding quality of our painting process. Though no thicker than a human hair, the layer of paint on an Audi is actually made up of four different coats. And with a matt effect paint finish as many as six. To ensure that your Audi is optimally protected from environmental influences and wear. And also outwardly reflects your personality.



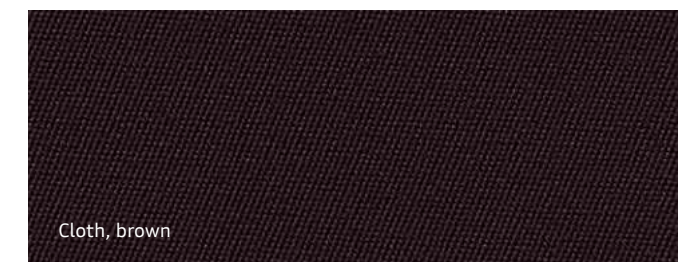
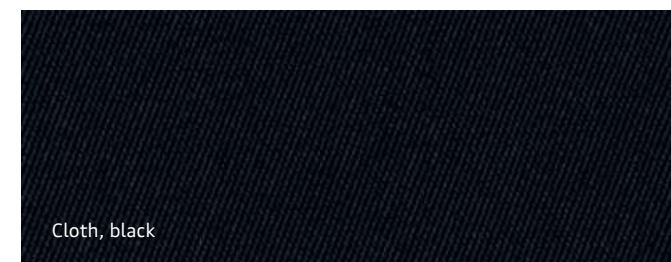
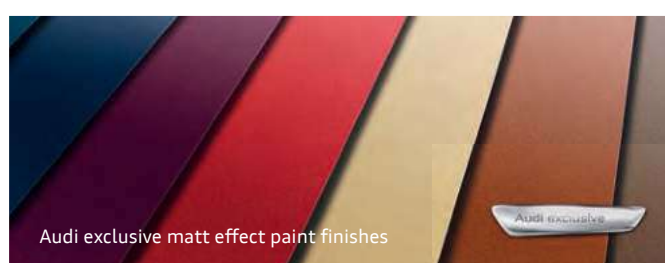
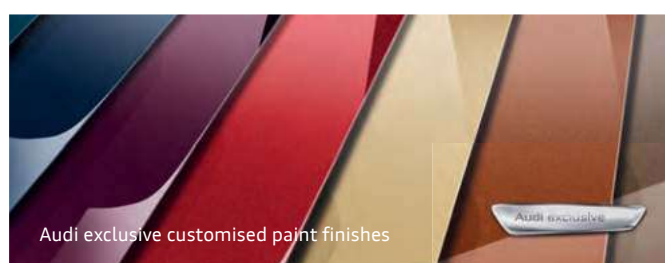
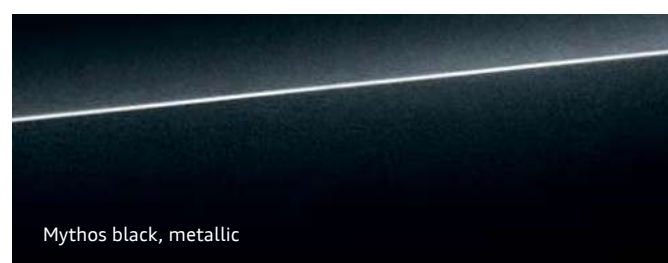
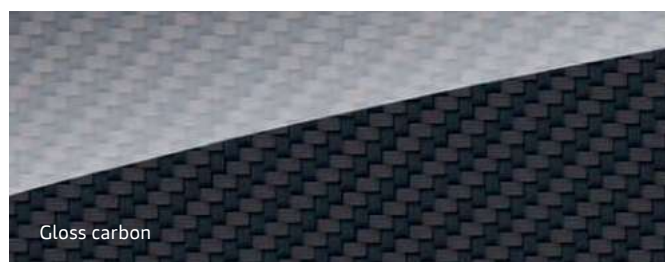
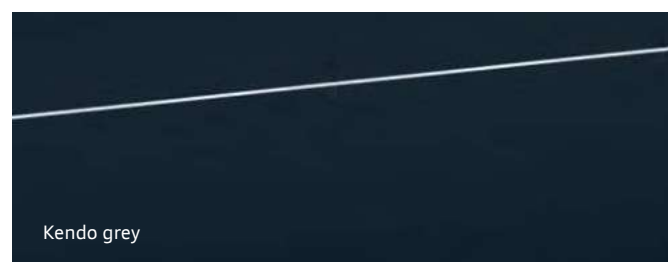
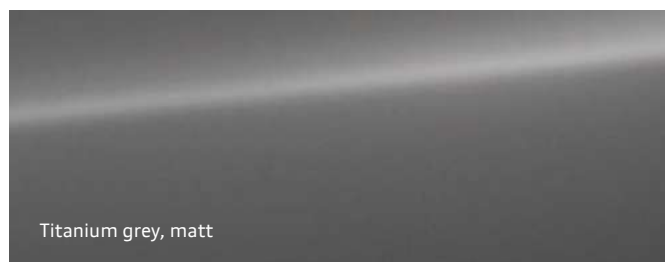

THE PERFECT CONNECTION BETWEEN AN AUDI AND THE ROAD.

Audi Sport wheels.

To make sure you have peace of mind for every metre of your drive, Audi Sport puts its wheels through an exacting series of specialised test procedures. Maximum strength is assured by conducting hardness tests, for example, while a copper accelerated salt spray test – CASS for short – using acetic acid guarantees the greatest possible corrosion protection. Thanks to these and many other measures, we can ensure that every Audi Sport wheel offers maximum quality – even after scores of kilometres.

No matter which of the numerous designs you choose.



19-inch cast aluminium wheels in 5-arm blade design in gloss anthracite black, gloss turned finish¹



19-inch cast aluminium wheels in 5-arm rotor design in matt titanium look, gloss turned finish¹



19-inch forged aluminium wheels in 10-spoke star design



19-inch forged aluminium wheels in 5-twin-spoke design in matt titanium look, gloss turned finish¹



20-inch forged aluminium wheels in 10-spoke Y design in gloss anthracite black



20-inch forged aluminium wheels in 5-arm trapezoidal design



20-inch aluminium fully milled wheels in 5-arm peak design in matt anthracite black, gloss milled finish¹



20-inch forged aluminium wheels in 7-spoke rotor design in gloss anthracite black, gloss turned finish¹



21-inch cast aluminium wheels in 5-twin-spoke design in matt titanium look, gloss turned finish¹



21-inch cast aluminium wheels in 5-V-spoke star design in gloss anthracite black, gloss turned finish¹



21-inch cast aluminium wheels in 5-spoke blade design



21-inch cast aluminium wheels in 5-twin-arm design in gloss anthracite black, gloss turned finish¹

Additional wheels can be found at www.audi.com

Some of the equipment listed or described is optional equipment that is available at an extra charge.

Please go to www.audi.com or visit your Audi partner for detailed information on standard and optional equipment.

You will find specifications on the technical characteristics of tyres on page 55.

¹ Please note the special information relating to wheels on page 49.

RELY ON THE RIGHT FIT.

And sporty lateral support.

You have a special place in your Audi. Sportiness and exclusivity can be felt on the front and rear seats. No matter whether you prefer the R8 bucket seats with their contoured seat style, the RS sport seats with shaped seat side bolsters or the more comfort-oriented customised contour seats: you're sitting in the right place.

R8 bucket seats

- ▶ More contoured seat shape for increased lateral support
- ▶ Sleek, highly sculpted design with integrated head restraint



RS sport seats, front (RS5, TT RS)

- ▶ Shaped seat side bolsters for increased lateral support
- ▶ Sporty look thanks to integrated head restraint and seat upholstery with diamond or honeycomb pattern

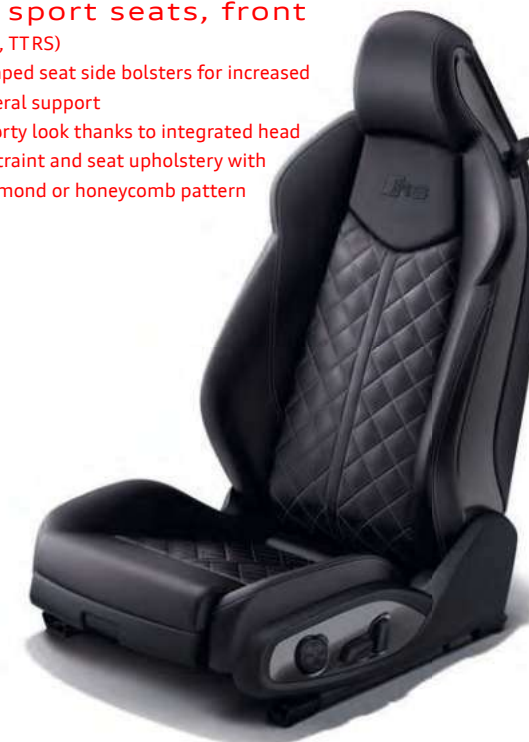

RS sport seats, front (RS3)

- ▶ Shaped seat side bolsters for increased lateral support
- ▶ Sporty look thanks to integrated head restraint and shoulder areas with diamond pattern



RS sport seats, front (RS6, RS7)

- ▶ Shaped seat side bolsters for increased lateral support
- ▶ Sporty look thanks to integrated head restraint and seat upholstery with diamond or honeycomb pattern



QUALITY WITH DISTINCTION.

When it comes to your seats.

High-quality materials and first-class workmanship characterise the seats, which have earned special distinction with regard to quality and feel: RS or R8. When selecting upholstery and colours you can therefore focus on what is important: your taste.

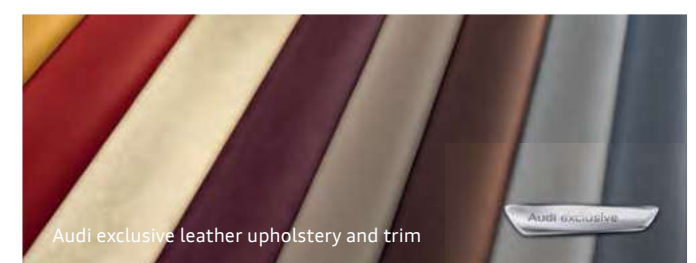
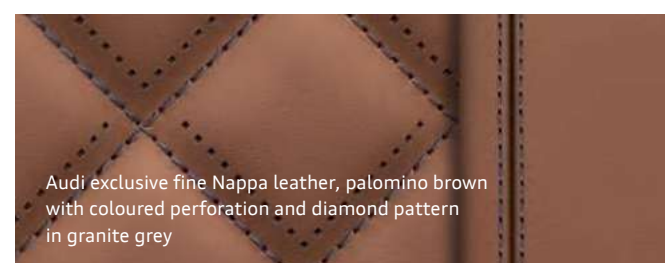
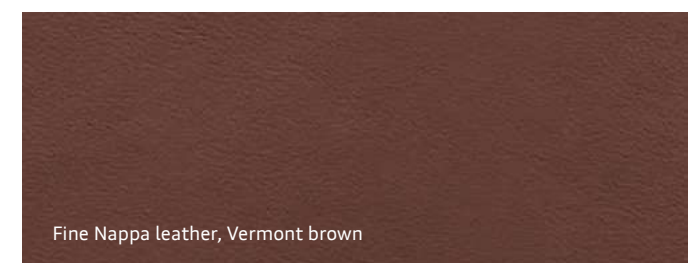
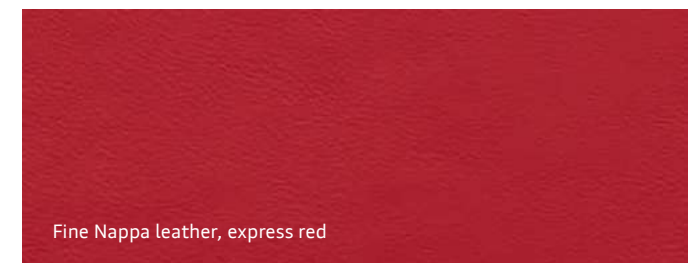
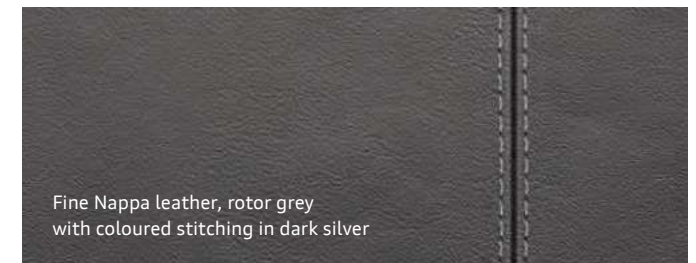
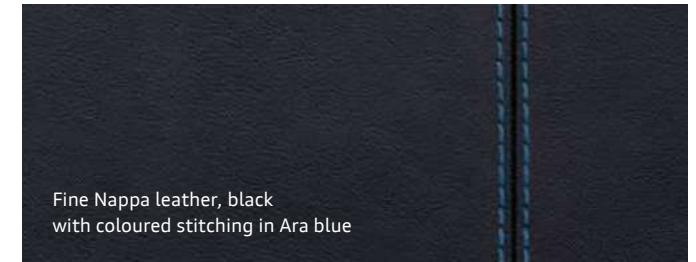
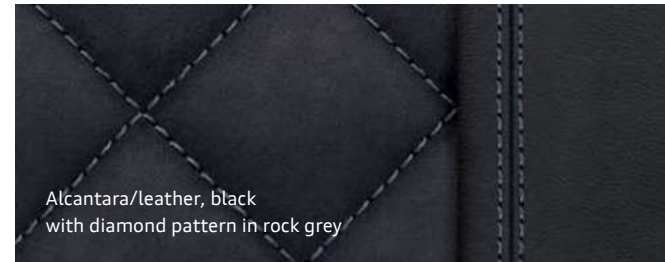

The equipment options included here vary depending on the particular Audi Sport model. Detailed information can be obtained at www.audi.com or from your Audi partner.

Additional seat upholstery options can be found at www.audi.com. Some of the equipment listed or described is optional equipment for which an extra charge is made. Please go to www.audi.com or visit your Audi partner for detailed information on standard and optional equipment.

EXPERIENCE FASCINATION.

Down to the last detail.

The exclusive Audi inlays emphasise the sporty ambience of your vehicle. At first sight. Be inspired by refined carbon, aluminium, piano finish or wood for the dashboard, centre console and door trims. High-quality and precise workmanship harmoniously integrated in the interior.

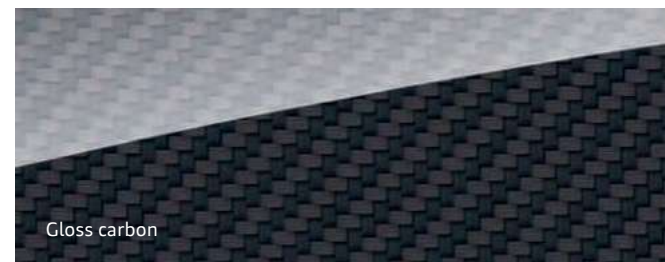

Gloss carbon

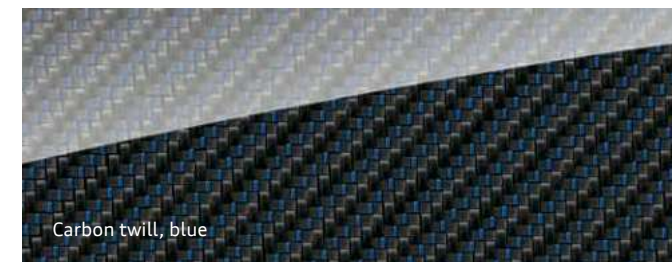

Carbon twill, blue



Aluminium race, anthracite



Anodised paint finish, anthracite

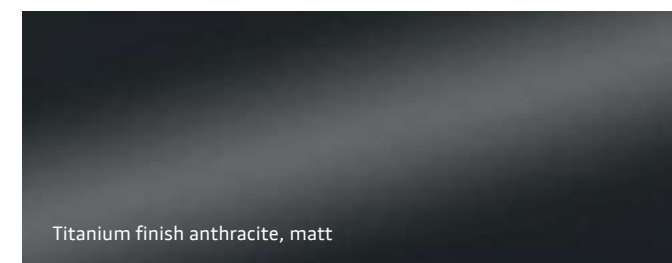

Titanium finish anthracite, matt



Audi exclusive piano finish, black



Audi exclusive aluminium/Beaufort wood, black



Audi exclusive painted inlays



Audi exclusive wood inlays

Additional inlays can be found at www.audi.com

The equipment options included here vary depending on the particular Audi Sport model.

Detailed information can be obtained at www.audi.com or from your Audi partner.

Some of the equipment listed or described is optional equipment for which an extra charge is made.

Please go to www.audi.com or visit your Audi partner for detailed information on standard and optional equipment.

SHOW YOUR PERSONALITY.

With the range of Audi exclusive
customisation options.

That the Audi exclusive range aspires to exclusivity is already evident from its name. Selected décors and coloured leather can be combined with customised paint finishes from the large selection of Audi exclusive colours to suit your own personal preferences. So you can highlight your car's exceptional character to even better advantage.



AUDI EXCLUSIVE. AUDI RS 7 SPORTBACK PERFORMANCE.

Driving an Audi RS model is about expecting more. Audi exclusive offers you a wealth of options for turning these expectations into your own personal statement. More vivid colours? More elegance? Be inspired: RS7 Sportback performance with Audi exclusive customised paint finish in camouflage green, metallic along with 21-inch cast aluminium wheels in 5-twin-arm design in matt titanium look, gloss turned finish¹.

Audi exclusive leather upholstery and trim (package 2) in Valcona leather with honeycomb pattern in cognac with contrasting stitching in black, Audi exclusive extended leather package in cognac with contrasting stitching in black, Audi exclusive controls in perforated leather, black with contrasting stitching in cognac, Audi exclusive floor mats in black with leather edging in cognac and contrasting stitching in black, Audi exclusive seat belts in cognac.



The figures for fuel consumption and CO₂ emissions can be found on page 49.

¹ Please note the special information relating to wheels on page 49.

Some of the equipment listed or described is optional equipment for which an extra charge is made.

Please go to www.audi.com or visit your Audi partner for detailed information on standard and optional equipment.

The equipment options included here vary depending on the particular Audi Sport model. Detailed information can be obtained at www.audi.com or from your Audi partner.

AUDI EXCLUSIVE. AUDI R8 COUPÉ V10 PLUS.

Make your Audi R8 unique – as unmistakable as you yourself – with Audi exclusive. R8 Coupé V10 plus with Audi exclusive customised paint finish in Nardo grey and sideblades with Audi exclusive matt effect paint finish in Vegas yellow as well as 20-inch forged aluminium wheels in 10-spoke Y design in gloss anthracite black. Audi exclusive fine Nappa full-leather upholstery and trim in jet grey/black with contrasting stitching in calendula yellow, Audi exclusive controls in leather in jet grey with contrasting stitching in calendula yellow, inlays in gloss carbon, Audi exclusive air vents and seat backrest covers painted in Vegas yellow, matt effect.



The figures for fuel consumption and CO₂ emissions can be found on page 46.
Some of the equipment listed or described is optional equipment for which an extra charge is made.
Please go to www.audi.com or visit your Audi partner for detailed information on standard and optional equipment.

The equipment options included here vary depending on the particular Audi Sport model.
Detailed information can be obtained at www.audi.com or from your Audi partner.

The vehicles and equipment versions illustrated and described in this product catalogue and some of the services listed are not available in all countries. Some of the cars illustrated are equipped with optional equipment for which an extra charge is made. Details concerning the delivery specifications, appearance, performance, dimensions and weights, fuel consumption and running costs of the vehicles were correct to the best of our knowledge at the time of going to press. Deviations from the colours and shapes shown in the illustrations may occur. No liability will be accepted for errors and printing errors. The right to introduce modifications is reserved. Not to be reproduced, including in part, without the written approval of AUDI AG.

This brochure is printed on paper made from pulp bleached without the use of chlorine.

Audi Sport GmbH
NSU-Strasse 24-32
74172 Neckarsulm
www.audi.com
April 2017

Printed in Germany
758/1101.00.18

