



Sheer  
Driving Pleasure



*THE NEW*  
**BMW M2**  
*COMPETITION.*



# THE NEW BMW M2 COMPETITION.

## *SELECT CAR!*



**18** Highlights



**22** Exterior colours

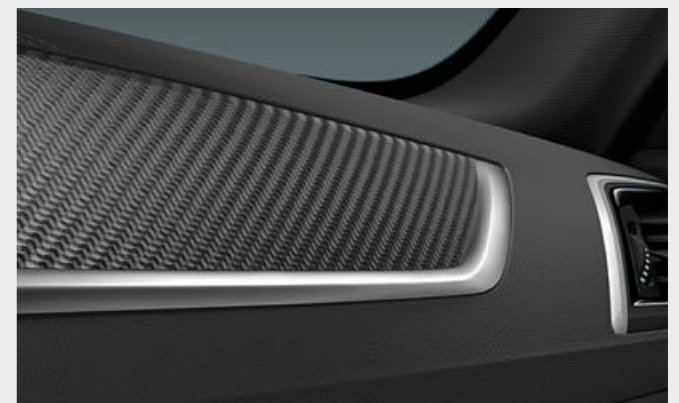

**24** Interior colours

## DIGITAL DISCOVERY: THE NEW BMW BROCHURES APP.

More information, more sheer driving pleasure: The new BMW brochures app offers a digital and interactive BMW experience like never before. Download the BMW brochures app for your smartphone or tablet now and rediscover your BMW.

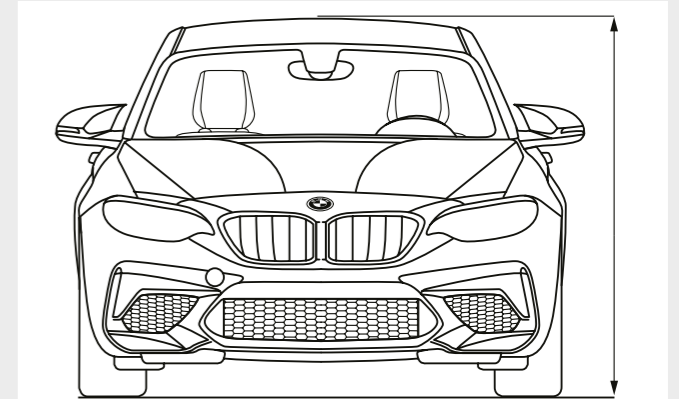

**26** Technical data

***START YOUR  
ENGINE!***



***DRIVING PLEASURE:  
NEXT LEVEL.***

LAP 1/3  
02:48.03 ⌚  
-00:01.42



***BOOST!***



**GREAT FUN. SERIOUSLY.**

M TWIN POWER TURBO ENGINE WITH 302 KW (410 HP) /// FROM 0 TO 100 KM/H IN 4.4 [4.2] SECONDS /// M SPORT BRAKES<sup>1</sup> /// M SERVOTRONIC /// 19" LIGHT ALLOY WHEELS DESIGN 788 M BLACK<sup>1</sup>

**NICE DRIFT!**



<sup>1</sup> Available as optional equipment. The figures for performance, fuel consumption and CO<sub>2</sub> emissions refer to vehicles with standard transmission. Values in [ ] are for vehicles with double-clutch transmission.

LAP 2/3  
05:11.16 🕒  
-00:03.12



*GO!*  
*GO!*  
**GO!**



**DOESN'T JUST RACE.  
BUT WINS.**

NEW KIDNEY GRILLE AND ENLARGED AIR INTAKES ///  
BMW CONNECTED DRIVE<sup>1</sup> WITH LAPTIMER APP /// BMW INDIVIDUAL  
HIGH-GLOSS SHADOW LINE



<sup>1</sup> Available as optional equipment.



**SOFT LEATHER SEATS.**

M LEATHER STEERING WHEEL WITH M1/M2 BUTTONS /// INTERIOR TRIM FINISHERS MADE OF OPEN-PORED CARBON<sup>1</sup> FIBRE /// M SPORT SEATS<sup>1</sup> WITH ILLUMINATED M2 LOGO IN DESIGN-PERFORATED LEATHER DAKOTA BLACK<sup>1</sup>

**BUT UNRELENTING PERFORMANCE.**



<sup>1</sup> Available as optional equipment.

***YOU WIN!***

LAP 3/3  
07:54.00 🕒  
-00:05.07



**#1**

# HIGHLIGHTS.

Discover more with the new BMW catalogue app. Now available for your smartphone and tablet.

■ Standard equipment □ Optional equipment



- Double round exhaust tailpipes left and right at the rear visually emphasise the vehicle's performance.
- The valve-operated, M sports exhaust system delivers either a particularly sporty or more low-key engine sound, depending on the driver's preference.



- The front end strut brace made of carbon fibre reinforced plastic (CFRP) is a significant body component in the engine compartment that comes from motor-sport vehicles. Though it weighs only 1.5 kg, it significantly increases front-end rigidity and contributes to greater steering precision and accuracy.



- Adaptive LED headlights with low-beam and high-beam headlights include Adaptive headlights and a high-beam assistant, among other things.



- The "M2 Competition" designation on the rear is an indication of the vehicle's extraordinarily high driving dynamic potential.



- BMW Individual high-gloss Shadow Line with extended contents includes numerous equipment details in Black high-gloss, e.g. the trim strips on the side frames, the window recess finishers, the frames and bases of the exterior mirrors, the front ornamental grille and the side air vent elements. The tailpipe trims come in Black Chrome.



- M door sill finishers with the "M2 Competition" designation on chrome-plated inserts in the front sills emphasise the vehicle's athletic ambitions and set the mood for the driving experience to come.



- The striking, characteristic M side air vent element highlights the car's athletic pedigree.



- The Front ornamental grille with black M double slats and a chrome-coloured frame adds a further touch of exclusivity to the front of the vehicle.



- 19" M light alloy wheels Y-spoke style 788 M with mixed tyres in black, forged, burnished, wheel size 9J x 19 front with 245/35 R19 tyres, wheel size 10J x 19 rear with 265/35 R19 tyres.

# HIGHLIGHTS.

Discover more with the new BMW catalogue app. Now available for your smartphone and tablet.

■ Standard equipment □ Optional equipment



■ The M TwinPower Turbo inline 6-cylinder petrol engine features superior power delivery and the striking characteristic M engine sound.

■ Featuring lightweight-construction axles and Active M differential, the M specific suspension exquisitely highlights the vehicle's dynamic potential.



■ Depending on the equipment, Multifunction for steering wheel can be used to operate the telephone, voice control and audio functions via the buttons on the steering wheel. The Manual Speed Limiter is also integrated. It can be used to set an upper limit of 50 km/h for city driving, for example.



■ Thanks to the use of a special material mix, M compound brakes achieve outstanding deceleration values and are extremely stable and highly durable.

□ The M Sport brake<sup>1</sup> with large compound brake discs is characterised by increased fading stability and thermal stability.



□ The multi-adjustable M Sport seats with bucket seat character and integrated headrest provide excellent lateral support for the driver and front passenger. In addition, the backrest width can be individually adjusted. Their special design with illuminated M2 logo highlights the vehicle's athletic capabilities.

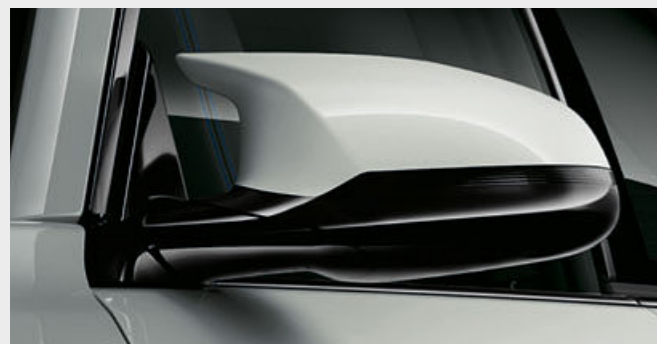

■ The aerodynamically optimised M exterior mirrors are a significant part of the sporty and dynamic M design. Attached to the body by a double-bridge designed base, they underscore the beautiful aesthetics of the car and convey a sense of precision engineering down to the last detail. The additional LED indicators are fitted perfectly into a long, narrow groove.



■ The M seat belts with belt tensioner and belt force limiter boast an exquisite woven highlight in the classic M colours.



■ The extended contents of the Instrument cluster include a high-resolution TFT display which can show navigation tips<sup>2</sup>, operational messages and various vehicle informations such as a notification of low windscreen wiper fluid.



□ Shift gears without losing power, using the clutch or slowing down: the 7-speed M double-clutch transmission with Drivelogic. Gears can be changed automatically or manually using the gearshift paddle switches on the steering wheel, or the gear selection lever. Launch Control guarantees maximum acceleration from a standing start.

<sup>1</sup> The image on the left shows the optional M Sport brake.  
<sup>2</sup> Only available in conjunction with the Professional Navigation system.

# EXTERIOR COLOUR WORLD.

Discover more with the new BMW catalogue app. Now available for your smartphone and tablet.

■ Standard equipment □ Optional equipment ○ Accessories



■ **Non-metallic** U300 Alpine White

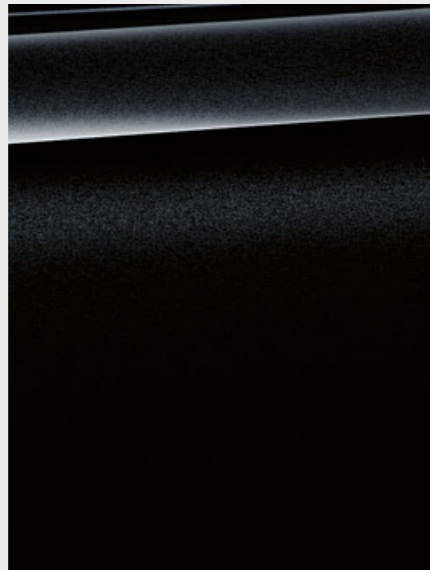

□ **Metallic** 475 Black Sapphire



□ **Metallic** C16 Long Beach Blue

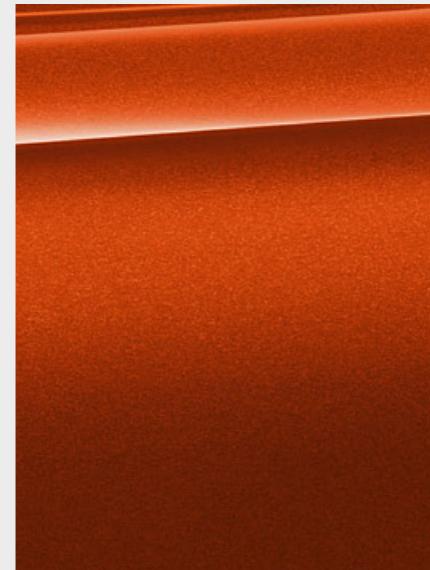

□ **Metallic** C1X Sunset Orange

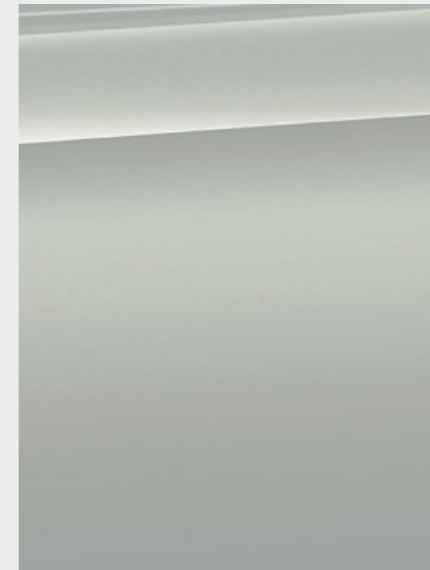

□ **Metallic** C33 Hockenheim Silver



## Power up an already impressive appearance:

○ The exclusive M Performance motorsport decal in the M colours further accentuates the sporty character of the vehicle and makes a clear reference to racing. The high-quality foil set is, of course, light, weather and car-wash resistant and is optimally matched to the vehicle geometry. For enhanced individuality.



DISCOVER MORE WITH THE  
NEW BMW CATALOGUE APP. NOW AVAILABLE  
FOR YOUR SMARTPHONE AND TABLET.

**[Colour samples]** These colour samples are intended as an initial guide to the colours and materials available for your BMW. However, experience has shown that printed versions of paint, upholstery and interior trim colours cannot in all cases faithfully reproduce the

appearance of the original colour. Please discuss your preferred colour choices with your BMW partner or in your dealership. There you can also see original samples and be assisted with special requests.

# INTERIOR COLOURS.

Discover more with the new BMW catalogue app. Now available for your smartphone and tablet.

■ Standard equipment □ Optional equipment



## UPHOLSTERY COLOURS

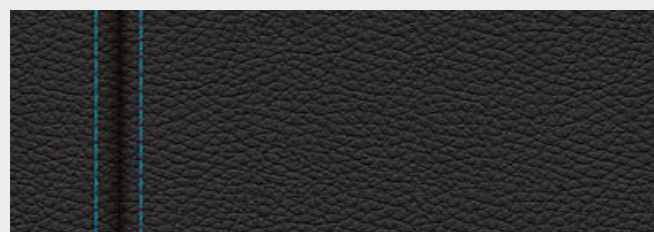

■ **Dakota leather** LCNL Black with contrast stitching in Blue

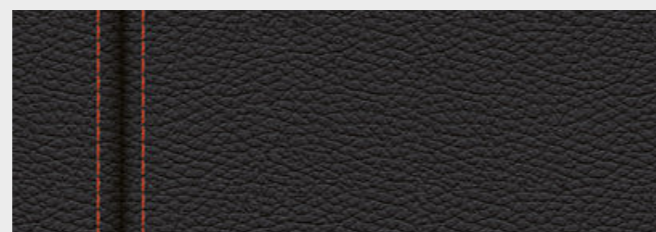

■ **Leather Dakota** LCNZ Black with contrast stitching orange

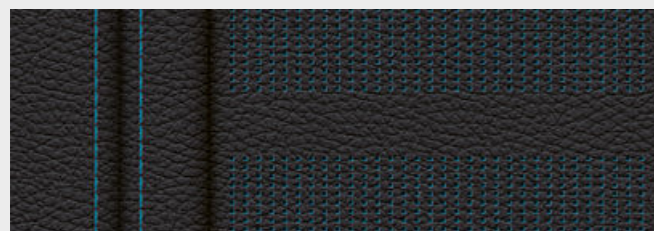

□ **Leather Dakota stylishly perforated** MDB2 Black/Blue<sup>1</sup>

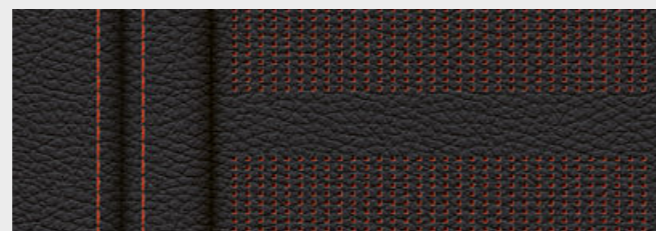

□ **Leather Dakota stylishly perforated** MDOE Black/Orange<sup>1</sup>

## INTERIOR TRIM

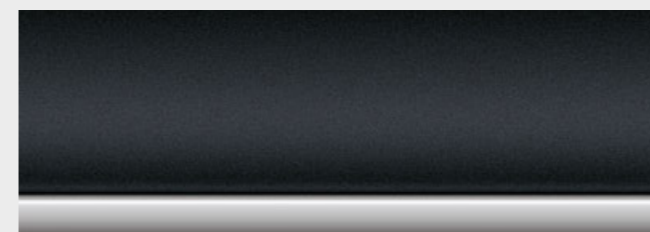

■ **4LU** Interior trim finishers Black high-gloss, highlight trim finisher Pearl Chrome

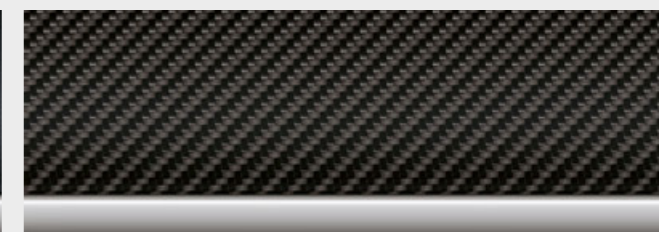

□ **4MC** Interior trim finishers Carbon Fibre, highlight trim finisher Pearl Chrome

Please note that even normal long- or short-term use can lead to unrecoverable upholstery damage.

This can be caused in particular by non-colourfast clothing.

<sup>1</sup> Only available in conjunction with M Sport seats.

## BMW M2 Competition

### Weight

Unladen EU <sup>1</sup>	kg	1625 [1650]
Maximum permissible weight	kg	2010 [2010]
Permitted load	kg	460 [435]
Luggage compartment capacity	l	390

### Engine

Cylinders/valves		6/4
Capacity	cc	2979
Rated output/rated engine speed	kW (hp)/rpm	302 (410)/5230-7000
Max. torque/engine speed	Nm/rpm	550/2350-5230

### Power transmission

Drive configuration	Rear-wheel drive
Standard transmission	Manual transmission

### Performance

Top speed	km/h	250 <sup>2</sup> [250] <sup>2</sup>
Acceleration 0-100 km/h	s	4.4 [4.2]

### Consumption<sup>3,4</sup> - All engines conform to the EU6 standard / Wheels

Urban	l/100 km	12.5-12.7 [11.2-11.5]
Extra-urban	l/100 km	8.3-8.4 [7.8]
Combined	l/100 km	9.8-10.0 [9.0-9.2]
Exhaust emissions standard (type-certified)		EU6
CO <sub>2</sub> emissions, combined	g/km	224-227 [206-209]
Tank capacity, approx.	l	52

### Wheels/tyres

Tyre dimensions		245/35 ZR 19 Y 265/35 ZR 19 Y
Wheel dimensions		9.0 J x 19 10.0 J x 19
Material		Light alloy

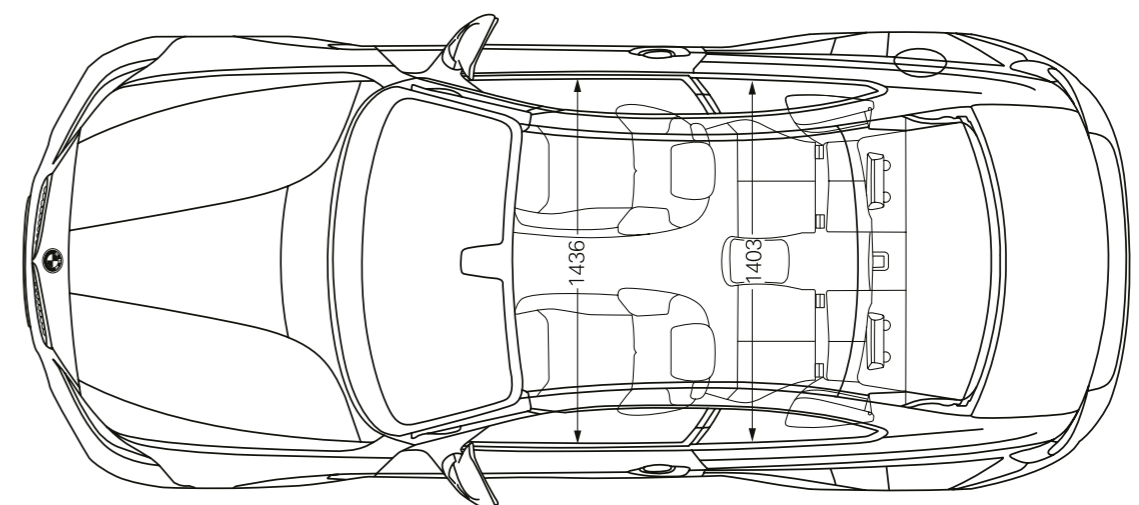
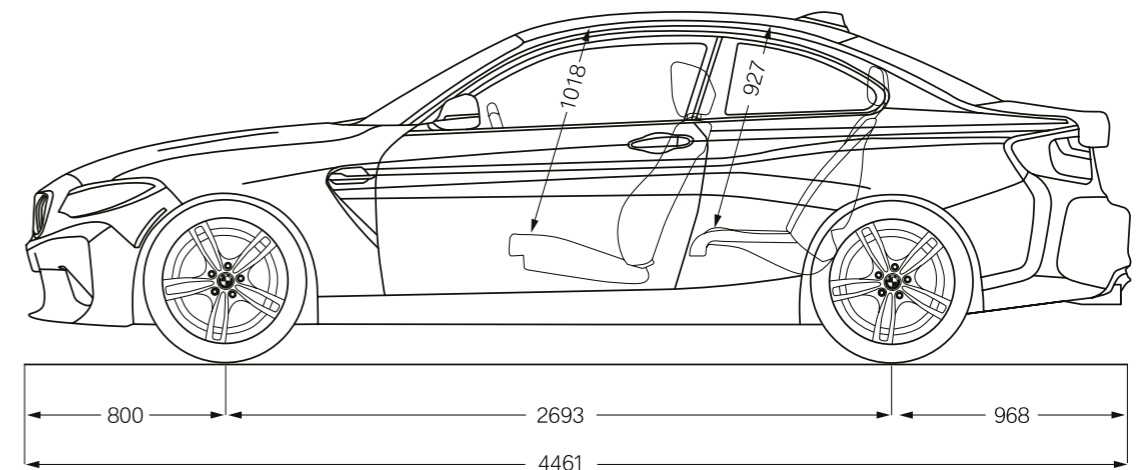
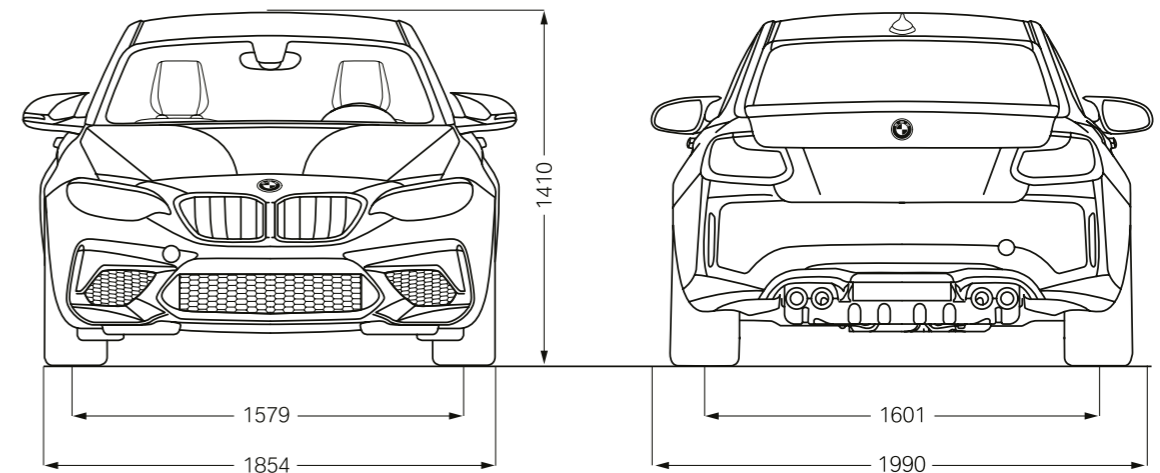

The figures for performance, fuel consumption and CO<sub>2</sub> emissions refer to vehicles with standard transmission. Values in [ ] are for vehicles with double-clutch transmission.

<sup>1</sup> The EC unladen weight refers to a vehicle with standard equipment and does not include any optional extras. The unladen weight includes a 90 % full tank and a driver weight of 75 kg. Optional equipment may affect the weight of the vehicle, the payload and the top speed if the selected equipment has an impact on the vehicle's aerodynamics.

<sup>2</sup> Electronically limited.

<sup>3</sup> Performance data of petrol engines apply to vehicles using RON 98 fuel. Fuel consumption data apply to vehicles using reference fuels in accordance with EU Regulation 2007/715. Unleaded RON 91 and higher with a maximum ethanol content of 10 % (E10) may also be used. BMW recommends RON 95 super unleaded petrol.

<sup>4</sup> The data for fuel consumption, CO<sub>2</sub> emissions and energy consumption were determined in accordance with the measurements processes as defined by European Regulation (EU) 2007/715 in the applicable version. Data refer to a vehicle with base-level equipment in Germany, and the ranges account for differences according to the selected wheel and tyre size and the optional equipment and may change during the configuration process. Figures have been determined on the basis of the new WLTP test cycle and have been converted back into NEDC figures for comparability. For these vehicles, values other than those specified here may apply for the assessment of taxes and other vehicle-related charges that are (also) based on CO<sub>2</sub> emissions.

**BMW M2 COMPETITION:**

M TwinPower Turbo 6-cylinder petrol engine, 302 kW (410 hp), 19" M light alloy wheels Y-spoke style 788 M Black, forged, with mixed tyres, Hockenheim Silver metallic exterior colour, M Sport seats in leather ,Dakota' stylishly perforated Black/ Blue, interior trim finishers ,Carbon Fibre'.

The models illustrated in this brochure show the equipment and configuration options (standard and optional) for vehicles produced by BMW AG for the German market. Alterations in standard and optional equipment and the configurations available for the different models, as described in this brochure, may occur after 04/27/2018, the date when this brochure went to press, or according to the specific requirements of other markets. Your local BMW Partner is available to provide further details. Subject to change in design and equipment.

© BMW AG, Munich, Germany. Reproduction, even in part, only with the written approval of BMW AG, Munich.

411 002 140 20 1 2018 BM. Printed in Germany 2018.

