

Mazda BT-50

zoom-zoom
zoom-zoom



Find us on Facebook

Motion should take you wherever you want to go

Let you do whatever you like

It should let you get that bit extra done

Or explore that bit further

And never ask you to compromise



There's always more to experience

Mazda BT-50 has the strength to take it on

The ability to do it all

With luxury that makes the most of it

And performance that makes it great

It's what we call Zoom-Zoom



THERE'S NO END TO WHERE IT CAN TAKE YOU

It's been built to do everything you need. And even more than that. Mazda BT-50 gets behind you with strength and ability proven in the toughest tests we could throw at it.

So pack it full of tools or hook up a big load, and you know it's going to come through. In fact with towing and payload capacities among the biggest around, you'll feel like nothing can stop you.

But there's much more to BT-50 than muscle. Because while sometimes there's work to be done, there's always life to be lived. So you get athletic design instead of boxy thinking. You access the latest entertainment and technology in a cabin that's more car than truck.

What's more, you feel like you're driving a smoothly responsive SUV, thanks to handling that echoes our sports car DNA. Add the latest in safety and driver aids, and you've got anything but the usual ute.



**ALL THE STRENGTH YOU NEED.
AND THEN SOME**

Taking on the big jobs or taking off for a long weekend, you shouldn't have to compromise. Good thing BT-50 is built to go one better. Its ladder frame chassis is thoroughly beefed up to be one of the most rigid of any ute. As well as giving you accurate car-like handling, it enables BT-50 to perform feats of strength others struggle to match. Like towing up to a huge 3,500kg²⁷ and making light work of payloads up to 1,509kg³.

You've also got more than most others under the bonnet. A new-generation turbo diesel engine utilises an advanced common-rail direct injection process to squeeze out more muscle from less fuel. Boosted by a lag-reducing variable geometry turbocharger, the

punchy 3.2 litre gives you 147kW and a massive 470Nm to easily overpower any challenge.

So how do you prefer to put the power down? A tough 6-speed manual puts full control in your hands, while the smart 6-speed auto will happily do all the work or let you make slick manual shifts.

With either, you can take on the rough stuff without breaking your stride. In 4x4 models, you flick between 2-High and 4-High on the move via a handy switch.

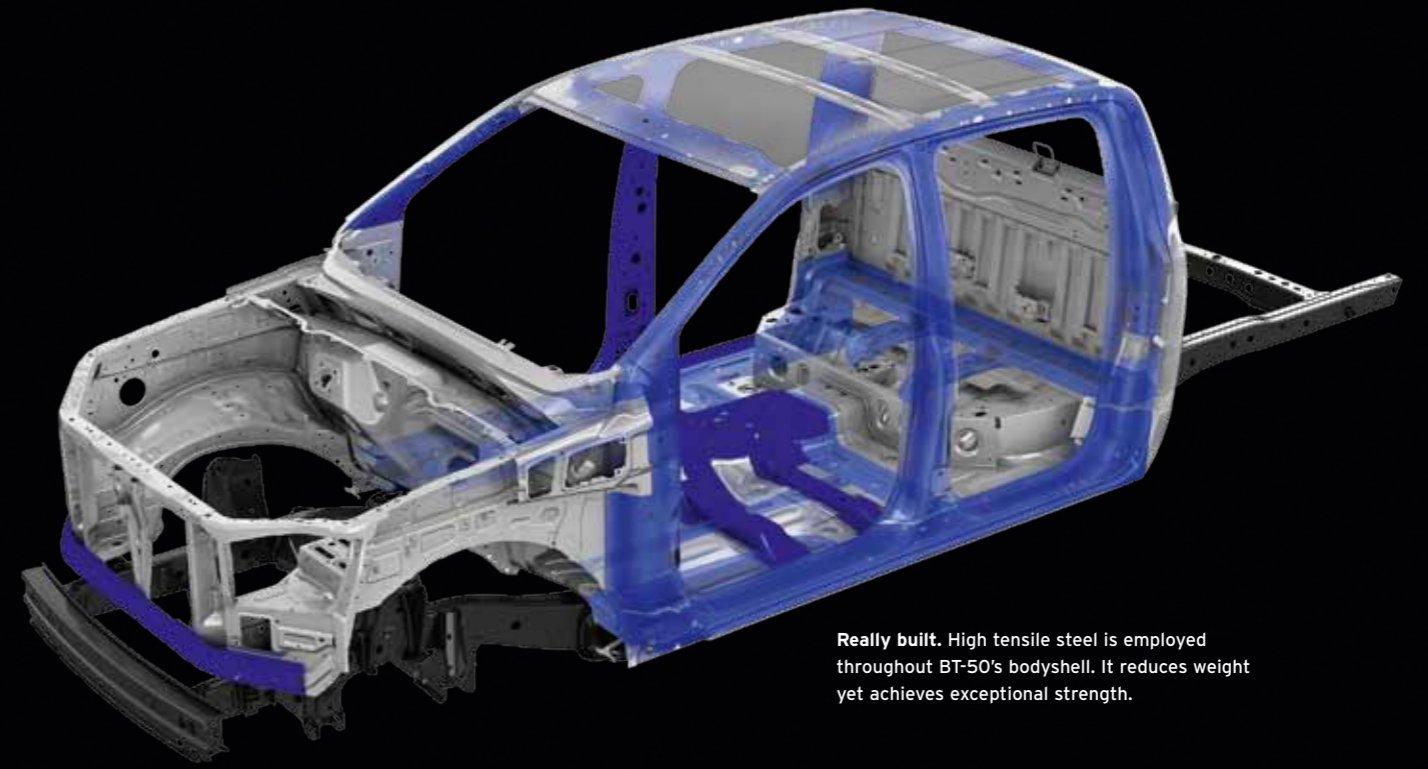

Really built. High tensile steel is employed throughout BT-50's bodyshell. It reduces weight yet achieves exceptional strength.



Underlying strength. A reinforced ladder frame chassis is capable of taking on the toughest jobs. Wishbone front and leaf rear suspensions deliver a car-like ride and handling with hardworking durability.



Power on. DOHC, common-rail direct injection, turbo charging and intercooling combine to create a big punch from small amounts of fuel. The 3.2 five-cylinder engine pumps out 147kW of power and 470Nm of torque from just 8.4 litres per 100km (combined).¹



The right gear. The rugged 6-speed manual's precision-shifting ratios make the most of the generous power available. The intelligent, seamlessly smooth 6-speed automatic lets you take manual control when the mood takes you. In auto mode, Active Adaptive Shift (AAS) intuitively selects the right gear for the conditions and your driving style.



YOU MIGHT NOT THINK YOU'RE IN A UTE

Wait a minute - is this really a ute? Mazda BT-50 welcomes you to the kind of comfort that's all too rare in this class. The cabin wraps around you with a sense of sophistication and all the latest tech, like displays detailing everything from audio to trip computer info. Right on the steering wheel you've got switches for cruise control, audio and the standard Bluetooth® functions. Pump up the volume and the MP3/WMA compatible CD player responds powerfully through 4 speakers in the Single Cab, plus 6 in the Freestyle and Double Cab models. USB connectivity and Bluetooth® streaming complement the performance. Need to make a few calls? Every model allows hands-free phone⁴ use. Oh, you get air con as standard too.

Of course, being a BT-50 there's more than you'd expect. Choose GSX and upgrade to premium cloth trim while your steering wheel wears luxurious leather. On a nice long drive or long day at work - you'll appreciate comforting touches like chrome highlights, floor carpeting and materials that are a cut above.

And, if you really want to experience a luxury not normally seen in a ute, sink back into the embrace of the black leather seat trim⁵ of the 4WD Double Cab Limited.

MP3 WMA Bluetooth®

SPACE. IT'S THE ULTIMATE EXTRA

From the ground up, BT-50 has been created to be bigger, stronger and better.

You'll feel it when you tow what you thought you couldn't, or load up more than ever before. And you'll definitely feel it when you jump inside. In every direction the spacious, sporty interior has been opened up to stretch comfort way beyond what you could ever expect.

Double Cab models can take on five full-size adults with no fear of arguments over personal space. Single Cab models accommodate you generously too, with split bench seating that combines a driver's bucket seat with room for two others.

Maybe you need something that's somewhere in-between? The clever Freestyle Cab gives you extra interior

practicality and seating for up to four, accessed by ingenious rear doors.

Sure you can carry heaps out back in BT-50's cargo box, but you might be surprised at what there's space for inside. Look beside you, above you and even under the rear seats in Freestyle and Double Cab, and you'll find a handy place to store drinks, sunnies, a set of tools and more.



Really connected. Bluetooth® enables hands-free phone⁴ use on the move and audio streaming.



The best of both worlds. The clever Freestyle Cab model gives you extra interior, practicality and seating accessed by an ingenious door system.



Comfy cuts. Standard black cloth seat trim is comfortable and durable.



All in. Huge load areas mean you can take on more cargo. BT-50 can carry payloads right up to a hefty 1,509kg³.



Haul away. Impressive strength and power make BT-50 one of the best towers around. It can haul up to a huge 3,500kg^{2,7} making light work of even the biggest loads. Optional tow bar shown above.

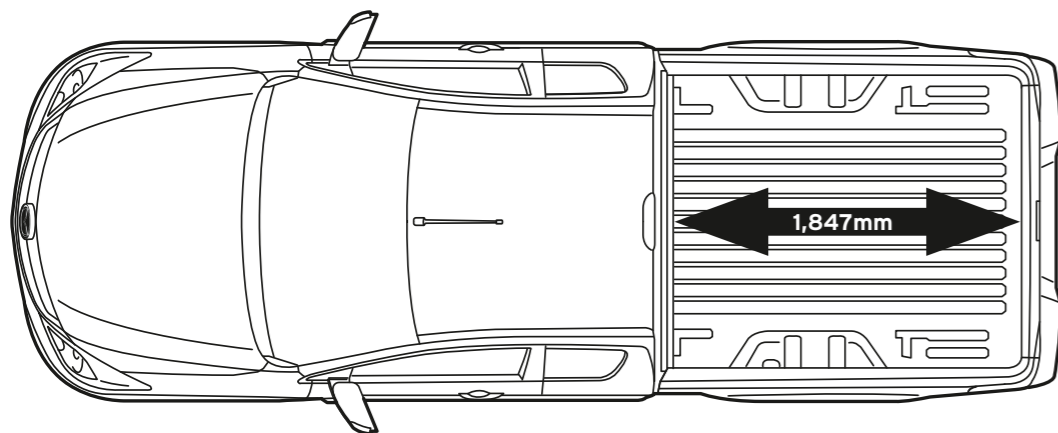

Freestyle Cab Utility

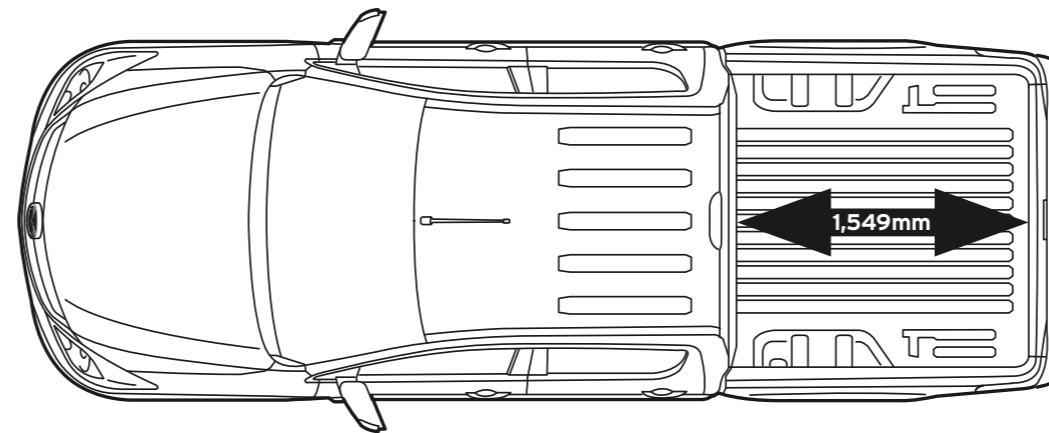

Double Cab Utility



Well placed. Handy storage spaces are all around you, including a split-level storage box in the centre console. The glove box is also big enough to take a 16 inch laptop.

Keep control. BT-50's superb on-road and confident off-road performance is boosted by impressive technology. In 4x4 models, Hill Descent Control (HDC) automatically applies brakes to maintain a steady, low speed down steep slopes. Control is greatly enhanced, particularly in off-road conditions.



4X4 DOUBLE CAB UTILITY LIMITED IN GUNMETAL BLUE MICA



No stopping you. Just flick the handy console switch and BT-50's electronically controlled transfer case lets you jump between 2-High and 4-High - without even needing to stop.



Locked on. On 4x4 models a Locking Rear Differential (LRD) maximises off-road grip by locking the rear wheels so both receive the same amount of torque. So even when one wheel has lost traction, the other can still provide drive. Can be engaged and disengaged via a console switch.

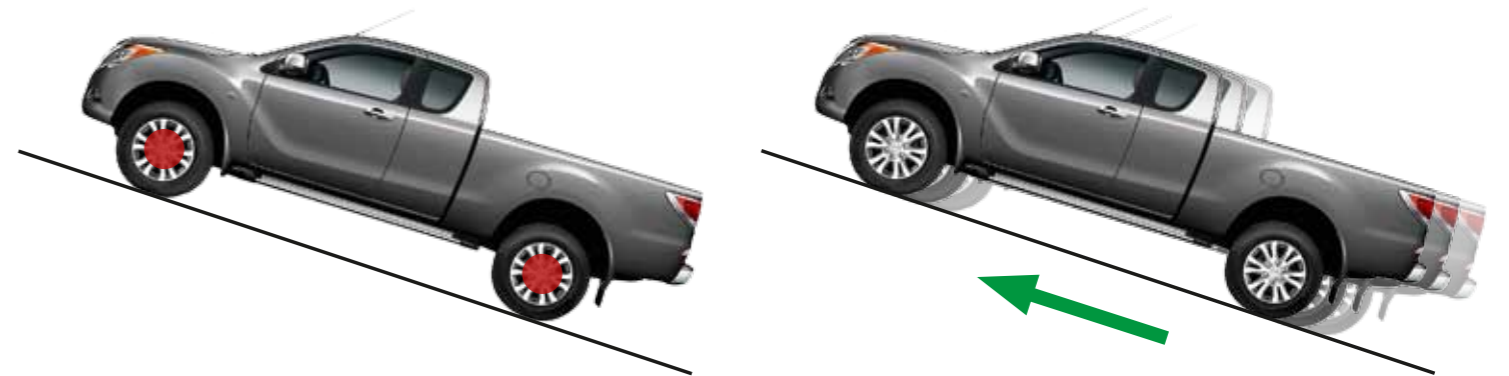

Perfect start. Safe, predictable starts on inclines are assured by Hill Launch Assist (HLA). It keeps the brakes applied as you remove your foot from the brake pedal to apply throttle. When there's enough torque for a smooth start, the brakes are released.

YOU'LL FEEL MORE THAN SAFE

Mazda BT-50 lets you do more than you'd expect from a pick-up. It's also picked up the maximum 5-Star ANCAP safety rating.

Its responsive handling and steering mean you're well placed to avoid potential trouble - yet, if anything does go wrong, an impressive safety arsenal is looking out for you. It begins with the superior occupant protection of a thoroughly reinforced body shell. Building your sense of safety are front airbags plus head-protecting curtain airbags in all models while Freestyle and Dual Cab models add side (front) airbags. All seats have three-position seatbelts, while front belts have pretensioners and load-limiters.

Two child restraint anchor points in the rear of Dual Cab and Freestyle Cab look after the kids. Every BT-50 has Dynamic Stability Control (DSC) incorporating Traction Control System (TCS) as standard.

What's more, the powerful brakes are backed up by ABS and Electronic Brake-force Distribution (EBD), which optimises braking force according to vehicle load. On top of that Emergency Brake Assist (EBA) monitors pedal application to recognise emergency braking, adding stopping power right when it's needed.



Deeply reassuring. High tensile steel and extensive reinforcing help achieve an occupant cell of exceptional strength. With up to six SRS airbags BT-50 provides superior occupant safety.

Safety at work. Sometimes cargo can raise your vehicle's centre of gravity. Roll Stability Control (RSC) closely monitors speed, steering angle and yaw rate, and if required, brakes individual wheels to help prevent a roll over. Load Adaptive Control (LAC) adjusts the ABS, DSC and Traction Control System (TCS) to optimise control in accordance with cargo weight and height.

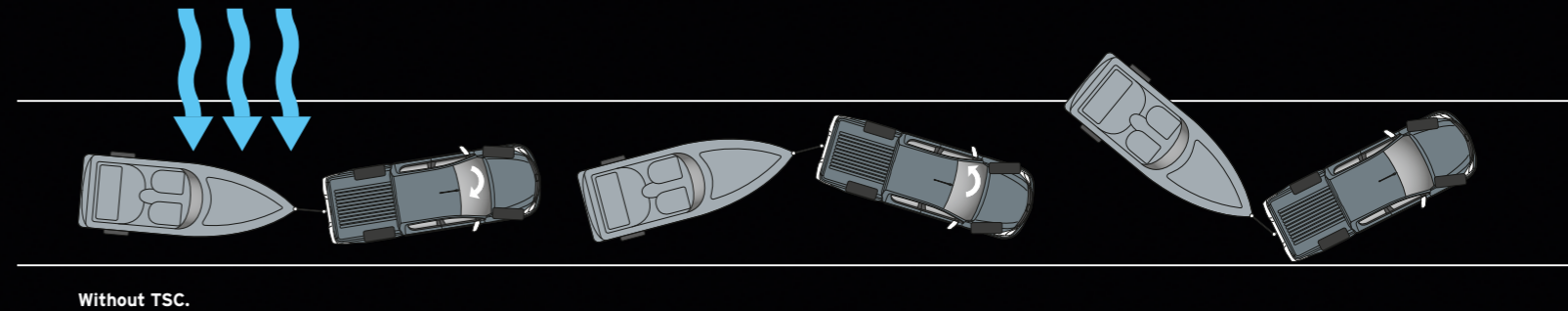
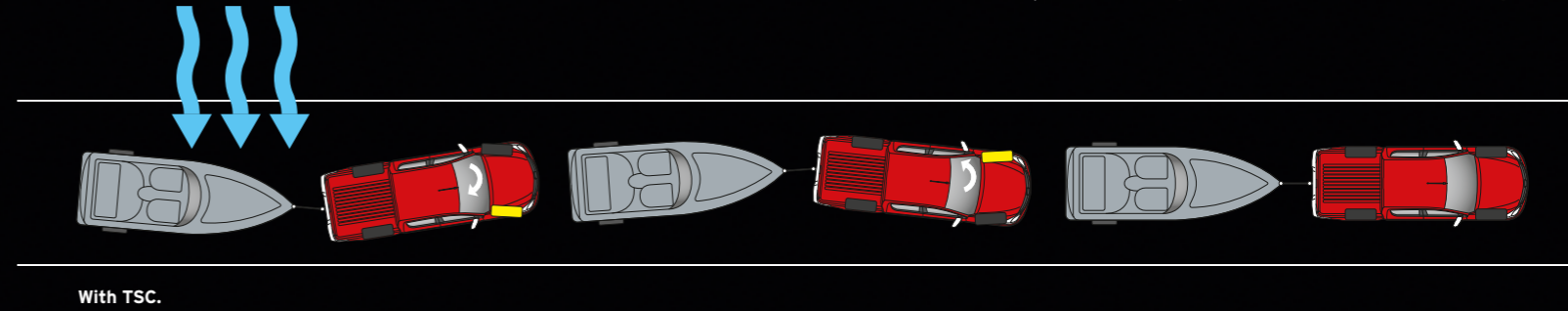
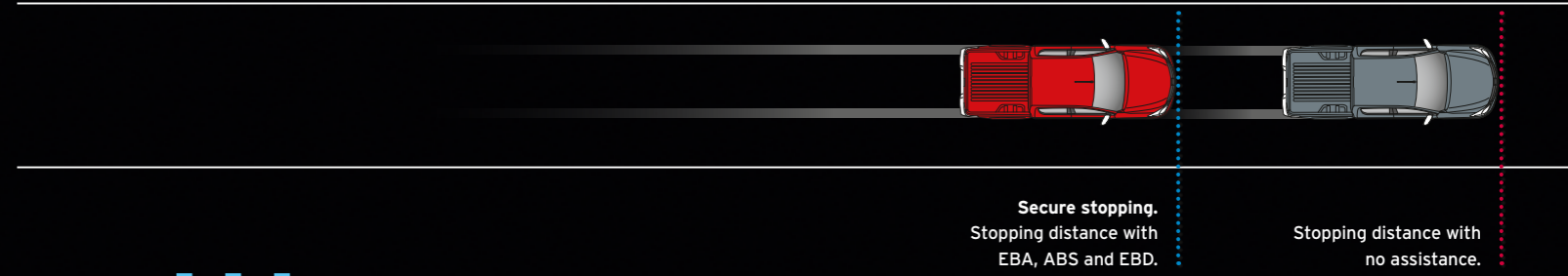

Straight and true. Gusts of wind or other factors can cause a trailer to start swaying. Trailer Sway Control (TSC) controls your wheels' rotation speed to reduce swaying and heighten stability.

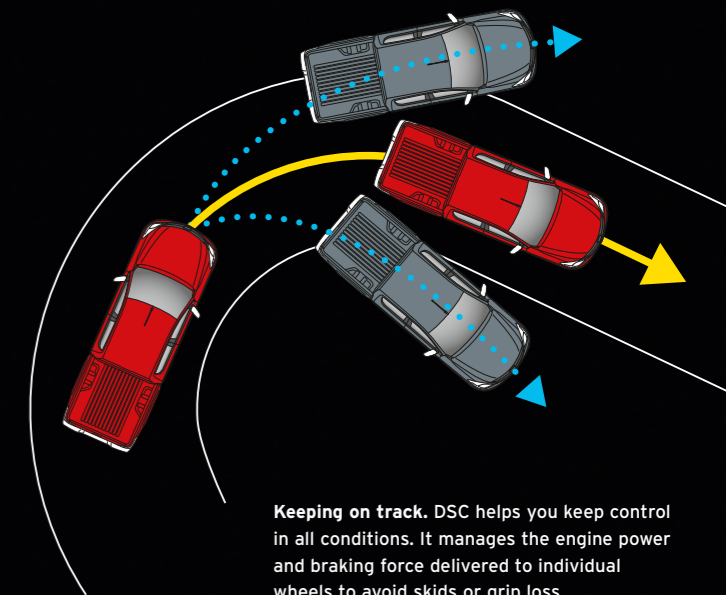

SINGLE CAB

Single Cab gives you all the comfort, technology and tough workhorse ability you'll ever need.

GLX

- 3.2 litre in-line 5-cylinder intercooled turbo diesel engine (147kW/470Nm)
- 80 litre fuel tank capacity
- 6-speed manual
- 16 inch steel wheels with 255/70 tyres
- Headlamps (Halogen)
- Power windows and mirrors (black)
- Air conditioning
- 5-Star ANCAP safety rating
- Bluetooth® (handsfree compatible)⁴
- Cruise control
- Trip Computer
- Floor covering: vinyl
- Audio system with: AM/FM tuner, single-disc CD player and 4 speakers
- USB input (iPod compatible)
- Airbags SRS: front (driver and passenger) and curtain (driver and passenger)
- Anti-lock Braking System (ABS)
- Dynamic Stability Control (DSC)
- Hill Launch Assist (HLA)
- Hill Descent Control (HDC) - 4x4 only
- Locking Rear Differential (LRD) - 4x4 only
- Ground clearance (laden): 200mm
- Payload³: from 1,353 kg (4x2 utility) to 1,509 kg (4x2 chassis)
- Towing capacity² (braked): 3,500kg^{2,7}



4x2
Cab Chassis GLX



4x2
Utility GLX



4x4
Cab Chassis GLX



Very accommodating. Single Cab's split bench seat combines a driver bucket with space for two others.



Keep informed. Trip computer details useful information such as fuel economy, distance to empty and more.



FREESTYLE CAB

Want more interior room and flexibility? Easy - a clever pillarless rear door frees up extra seating and storage.

GLX

- 3.2 litre in-line 5-cylinder intercooled turbo diesel engine (147 kW / 470 Nm)
- 80 litre fuel tank capacity
- 6-speed manual
- 16 inch steel wheels with 255/70 tyres
- Headlamps (halogen)
- Power windows and mirrors (black)
- Air-conditioning
- 5-Star ANCAP safety rating
- Bluetooth® (hands-free compatible)⁴
- Cruise control
- Floor covering: vinyl
- Trip computer
- Audio system with: AM/FM tuner, single-disc CD player and 6 speakers
- Bluetooth® audio (MP3 player compatible)⁴
- USB input (iPod compatible)
- Airbags SRS: front (driver and passenger), side (front) and curtain (front and rear)
- Anti-lock Braking System (ABS)
- Child restraint anchor points (2)
- Dynamic Stability Control (DSC)
- Hill Descent Control (HDC) - 4x4 only
- Hill Launch Assist (HLA)
- Locking Rear Differential (LRD) - 4x4 only
- Ground clearance (laden): 200 mm
- Payload³: from 1,298 kg (4x2 utility) to 1,431 kg (4x2 chassis)
- Towing capacity² (braked): 3,500kg^{2,7}



4x2
Cab Chassis GLX



4x2
Utility GLX



4x4
Cab Chassis GLX



4x4
Utility GLX



4x4
Cab Chassis GLX Plus

4x4 Freestyle Cab Chassis GLX Plus

Features additional to the GLX:

- 4x4 Cab Chassis configuration
- 17 inch alloy wheels with 265/65 tyres
- Door handles (chrome)
- Power mirrors (chrome)
- Side steps (aluminium)
- Ground clearance (laden): 205mm
- Payload³: 1,163 kg



Freestyle freedom. Freestyle Cab's clever door system opens up extra versatility.



Just cruising. Selecting and setting your speed is easy via wheel-mounted controls.



DOUBLE CAB

Seriously heavy duty or a family day out - the more you want to do, the more Double Cab's space and versatility have to offer.

GLX

- 3.2 litre in-line 5-cylinder intercooled turbo diesel engine (147 kW / 470 Nm)
- 80 litre fuel tank capacity
- 6-speed manual or 6-speed automatic - utilities only
- 16 inch steel wheels with 255/70 tyres
- Headlamps (halogen)
- Power windows and mirrors (black)
- Rear step bumper (black) - utilities only
- Air-conditioning
- 5-Star ANCAP safety rating
- Bluetooth® (hands-free compatible)⁴
- Cruise control
- Floor covering: vinyl
- Trip computer
- Audio system with: AM/FM tuner, single-disc CD player and 6 speakers
- Bluetooth® audio (MP3 player compatible)⁴
- USB input (iPod® compatible)
- Airbags SRS: front (driver and passenger), side (front) and curtain (front and rear)
- Anti-lock Braking System (ABS)

- Child restraint anchor points (2)
- Dynamic Stability Control (DSC)
- High mount stop lamp - utilities only
- Hill Descent Control (HDC) - 4x4 only
- Hill Launch Assist (HLA)
- Locking Rear Differential (LRD) - 4x4 only
- Ground clearance (laden): 200 mm
- Payload³: from 1,139 kg (4x4 utility auto) to 1,271 kg (4x4 chassis)
- Towing capacity² (braked): 3,500kg^{2,7}

GSX

Features additional to the GLX:

- 17 inch alloy wheels with 265/65 tyres
- Air conditioning (dual-zone climate control)⁶
- Door handles (chrome)
- Fog-lamps (front)
- Power mirrors (chrome)
- Rear step bumper (chrome)
- Side steps (aluminium finish)
- Ambient temperature gauge
- Floor covering: carpet
- Leather wrapped: gear shift knob and steering wheel
- Payload³: from 1,097 kg (4x4 GSX auto) to 1,221 kg (4x2 GSX manual)
- Rear parking sensors⁶

Limited

Features additional to the GSX:

- Headlamps auto on/off function
- Rear-view mirror with auto dimming function
- Seat trim: leather^{5/6} with 8-way power adjustment
- Wipers (front) 2-speed with rain-sensing function
- Payload³: 1,088 kg



4x2
Utility GLX



4x2
Utility GSX



4x4
Cab Chassis GLX



4x4
Utility GLX



4x4
Utility GSX



4x4
Utility Limited



Feels fantastic. Supportive sports seats trimmed in rich, luxurious leather⁵ on Limited and black cloth on GLX and GSX.



Secret spot. Lifting the rear seat reveals useful extra storage space.



4x2 SPECIFICATIONS

	4x2 Single Cab GLX	4x2 Freestyle Cab GLX	4x2 Double Cab GLX	4x2 Double Cab GSX
Powertrain	3.2 litre in-line 5 cylinder 20 valve DOHC intercooled turbo diesel			
Engine type	3,198 cc			
Engine capacity	89.0 mm x 100.7 mm			
Bore and stroke	15.5 : 1			
Compression ratio	147 kW @ 3,000 rpm			
Maximum power	470 Nm @ 1,750 - 2,500 rpm			
Maximum torque	Electronic (drive-by-wire)			
Throttle control	Common-rail, electronic direct injection			
Fuel system	80 litres			
Fuel tank capacity	Diesel			
Recommended fuel	8.4 litres per 100 km			
Fuel consumption ¹	man (combined)	-	8.9 litres per 100 km	8.9 litres per 100 km
	auto (combined)	-	-	-
Emissions standard	Euro stage IV			
Alternator	12 volts - 110 amps			
Manual transmission	6-speed			
Automatic transmission	-	-	6-speed	6-speed
Gear ratio - man/auto	1st	5.441 / -	5.441 / -	5.441 / 4.171
	2nd	2.839 / -	2.839 / -	2.839 / 2.342
	3rd	1.721 / -	1.721 / -	1.721 / 1.521
	4th	1.223 / -	1.223 / -	1.223 / 1.143
	5th	1.000 / -	1.000 / -	1.000 / 0.867
	6th	0.794 / -	0.794 / -	0.794 / 0.691
	reverse	4.935 / -	4.935 / -	4.935 / 3.403
	final drive	3.550 / -	3.550 / -	3.550 / 3.730

Chassis				
Brake diameter	front	302 mm		
	rear	270 mm		
Brake type	front	Ventilated disc		
	rear	Drum		
Steering type	Rack and pinion hydraulic power assist steering			
Suspension type	front	Independent double wishbone with coil over dampers and anti-roll bar		
	rear	Rigid (live) rear axle with leaf springs		
Turning circle	kerb to kerb	12.4 m	12.4 m	12.4 m
Tyre size		255/70 R16	255/70 R16	255/70 R16
Tyre index		111T	111T	112T
Wheel size		16 x 7.0 J	16 x 7.0 J	16 x 7.0 J
Wheel type		Steel	Steel	Alloy
Wheel size (spare)		16 x 7.0 J	16 x 7.0 J	17 x 7.5 J
Wheel type (spare)		Steel	Steel	Steel

Weights and Capacities				
Axle capacity	front	1,480 kg	1,480 kg	1,480 kg
	rear	1,850 kg	1,850 kg	1,850 kg
Gross Combined Mass (GCM) ²	man	5,950 kg	5,950 kg	5,950 kg
	auto	-	-	5,950 kg
Gross Vehicle Mass (GVM)	man	3,200 kg	3,200 kg	3,200 kg
	auto	-	-	3,200 kg
Kerb weight	man	1,691 kg - 1,847 kg	1,769 kg - 1,902 kg	1,951 kg
	auto	-	-	1,964 kg
Payload ³	man	1,353 kg - 1,509 kg	1,298 kg - 1,431 kg	1,221 kg
	auto	-	-	1,236 kg
Seating capacity		3	4	5
Tow ball download	maximum	235 kg	235 kg	235 kg
Towing capacity ^{2,7}	braked	3,500 kg	3,500 kg	3,500 kg
	unbraked	750 kg	750 kg	750 kg

	A E 4x2 Single Cab GLX	B F 4x2 Freestyle Cab GLX	C 4x2 Double Cab GLX	D 4x2 Double Cab GSX
--	---------------------------	------------------------------	-------------------------	-------------------------

Dimensions				
Cargo box floor height to ground	835 mm (utility)	835 mm (utility)	835 mm	841 mm
Cargo box floor length	2,317 mm (utility)	1,847 mm (utility)	1,549 mm	1,549 mm
Cargo box floor width	1,560 mm (utility)	1,560 mm (utility)	1,560 mm	1,560 mm
Cargo box height	513 mm (utility)	513 mm (utility)	513 mm	513 mm
Cargo box tailgate opening width	1,330 mm (utility)	1,330 mm (utility)	1,330 mm	1,330 mm
Cargo box top length	2,253 mm (utility)	1,783 mm (utility)	1,485 mm	1,485 mm
Cargo box top width	1,500 mm (utility)	1,500 mm (utility)	1,500 mm	1,500 mm
Cargo box width between wheel arches	1,139 mm (utility)	1,139 mm (utility)	1,139 mm	1,139 mm
Ground clearance	laden	200 mm	200 mm	205 mm
	unladen	232 mm	232 mm	237 mm
Overall length	5,124 mm - 5,373 mm (for utility model)	5,124 mm - 5,373 mm (for utility model)	5,373 mm	5,365 mm
Overall width	1,850 mm	1,850 mm	1,850 mm	1,850 mm
Overall height	1,800 mm	1,804 mm	1,815 mm	1,821 mm
Overhang	front	919 mm	919 mm	919 mm
	rear	985 mm - 1,234 mm	985 mm - 1,234 mm	1,234 mm
Track	front	1,560 mm	1,560 mm	1,560 mm
	rear	1,560 mm	1,560 mm	1,560 mm
Wading depth	800 mm	800 mm	800 mm	800 mm
Wheelbase	3,220 mm	3,220 mm	3,220 mm	3,220 mm
Approach angle	27.6°	27.6°	27.6°	28.2°
Departure angle	28.4°	28.4°	27.1°	26.4°
Ramp breakover angle	24.4°	24.4°	24.4°	25.0°

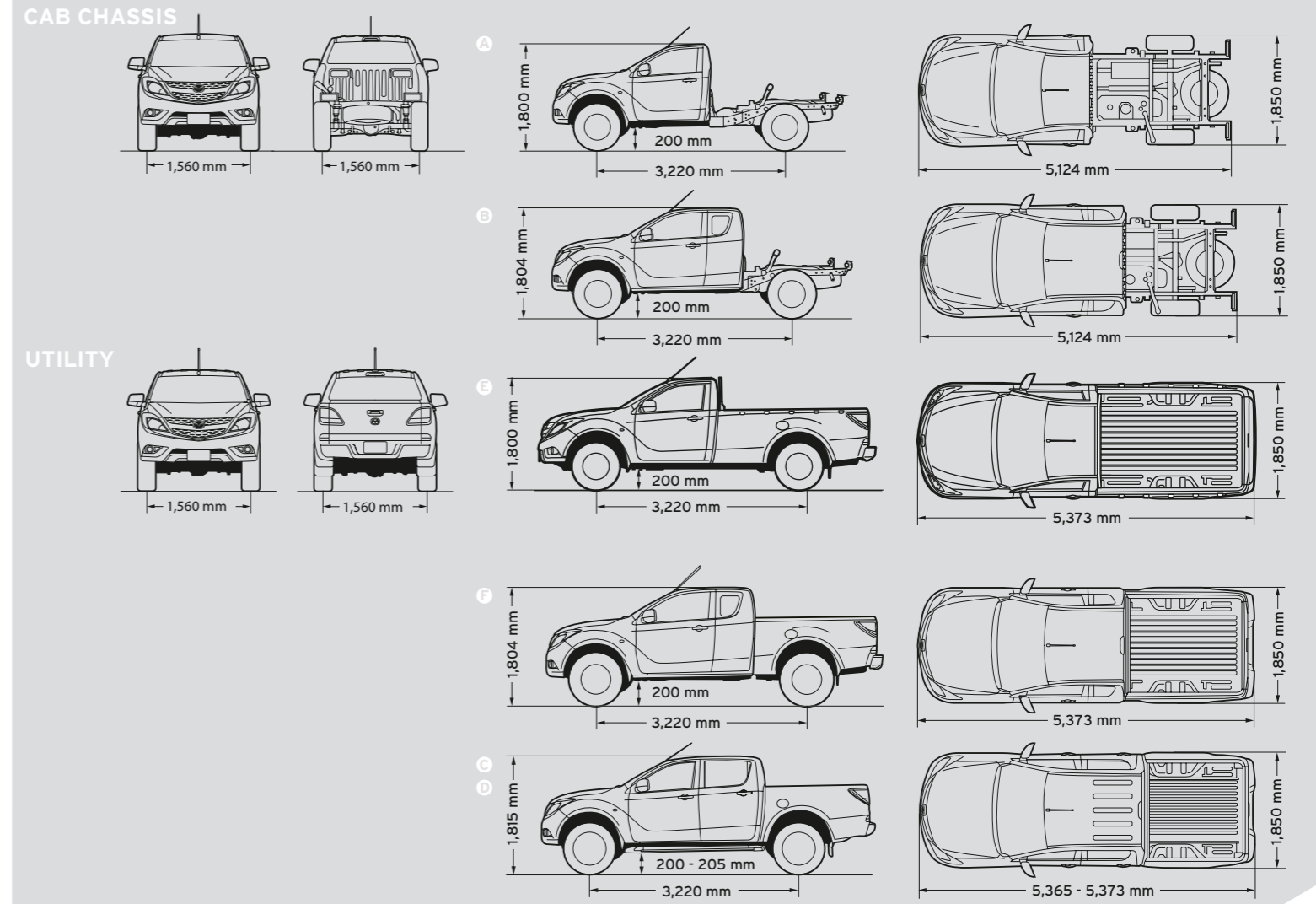

4x2 SPECIFICATIONS

4x2
Single Cab
GLX

4x2
Freestyle Cab
GLX

4x2
Double Cab
GLX

4x2
Double Cab
GSX

Exterior

Cargo box features:	centre tailgate release (black)	Utility	Utility	●	–
	centre tailgate release (chrome)	–	–	–	●
	double wall construction	Utility	Utility	●	●
	interior rope hooks (6)	Utility	Utility	●	●
Door handles (black)		●	●	●	–
Door handles (chrome)		–	–	–	●
Fog-lamps (front)		–	–	–	●
Freestyle door system		–	●	–	–
Front bumper (body coloured)		●	●	●	●
Fuel filler cap (lockable)	● (with key on C/C)	● (with key on C/C)	●	●	●
Green tinted windscreen, side and rear windows		●	●	●	●
Headlamps (halogen)		●	●	●	●
Metallic/Mica paint		●	●	●	●
Mudflaps (front)		●	●	●	●
Mudflaps (rear)		Utility	Utility	●	●
Power mirrors (black)		●	●	●	–
Power mirrors (chrome)		–	–	–	●
Power windows		●	●	●	●
Rear step bumper (black)		Utility	Utility	●	–
Rear step bumper (chrome)		–	–	–	●
Side steps (aluminium finish)		–	–	–	●

Interior

Air-conditioning		●	●	●	●
Air-conditioning (dual-zone climate control)		–	–	–	● ⁶
Ambient temperature gauge		–	–	–	●
Auxiliary 12 volt power outlets		●	●	●	●
Bluetooth® (hands-free compatible) ⁴		●	●	●	●
Centre armrest console with dual compartments		–	●	●	●
Critical function warning lights/chimes		●	●	●	●
Cruise control		●	●	●	●
Cupholders		●	●	●	●
Door pockets		●	●	●	●
Driver's left footrest		●	●	●	●
Floor covering:	carpet	–	–	–	●
	vinyl	●	●	●	–
Glove box		●	●	●	–
Glove box (lockable and illuminated)		–	–	–	●
Illuminated entry system with delayed fade		●	●	●	●
Instrument panel light dimmer		●	●	●	●
Interior illumination:	dome lamp	–	●	●	●
	map reading spot lamps	●	●	●	●
	power window switch (driver)	●	●	●	●
Leather-wrapped:	gear shift knob	–	–	–	●
	steering wheel	–	–	–	●
Low fuel warning light		●	●	●	●
Overhead sunglass storage box		●	●	●	●
Passenger assist grips		●	●	●	●
Seat trim:	cloth	●	●	●	●
Seat (driver's bucket) with:	adjustable head restraint	●	●	●	●
	height and lumbar adjustment	–	–	–	●
	rake and slide adjustment	●	●	●	●
Seat (passengers' front bench) with:	adjustable head restraint	●	–	–	–
Seat (passengers' front bucket) with:	adjustable head restraint	–	●	●	●

4x2
Single Cab
GLX

4x2
Freestyle Cab
GLX

4x2
Double Cab
GLX

4x2
Double Cab
GSX

Interior (continued)

Seat (passengers' front bucket) with:	rake and slide adjustment	–	●	●	●
	seat back pocket	–	●	●	●
Seat (passengers' rear bench) with:	adjustable head restraints	–	–	●	●
	foldable seat base and under-seat storage	–	–	●	●
Seat (passengers' rear jump) with:	removable seat base and under-seat storage	–	●	–	–
Tachometer and electronic odometer/tripmeter		●	●	●	●
Tilt-adjustable steering wheel		●	●	●	●
Trip computer (current and average fuel consumption, distance to empty and average vehicle speed)		●	●	●	●
Vanity mirror (front passenger)		●	●	●	●
Window demister (rear)		●	●	●	●
Wipers (front) 2-speed with variable intermittent function		●	●	●	●

Audio

AM/FM tuner		●	●	●	●
Auxiliary input (3.5mm MP3 player compatible)		●	●	●	●
Bluetooth® audio (MP3 player compatible) ⁴		●	●	●	●
CD player, single disc (MP3/WMA compatible)		●	●	●	●
Speakers (4)		●	–	–	–
Speakers (6)		–	●	●	●
Steering wheel-mounted audio controls		●	●	●	●
USB input (iPod compatible)		●	●	●	●

Safety

5-Star ANCAP safety rating		●	●	●	●
Airbags SRS:	front (driver and passenger)	●	●	●	●
	side (front)	–	●	●	●
	curtain (front)	●	–	–	–
	curtain (front and rear)	–	●	●	●
Anti-lock Braking System (ABS)		●	●	●	●
Child restraint anchor points (2)		–	●	●	●
Childproof rear door locks		–	–	●	●
Dynamic Stability Control (DSC) - switchable on/off		●	●	●	●
Electronic Brake-force Distribution (EBD)		●	●	●	●
Emergency Brake Assist (EBA)		●	●	●	●
Engine immobiliser		●	●	●	●
Emergency Stop Signal (ESS)		●	●	●	●
High mount stop lamp		Utility	Utility	●	●
Hill Launch Assist (HLA)		●	●	●	●
Intrusion-minimising brake pedal		●	●	●	●
Left-hand-side convex (wide angle) exterior mirror		●	●	●	●
Load Adaptive Control (LAC)		●	●	●	●
One touch (up and down) power window (driver)		●	●	●	●
Remote central locking (2 transmitters with retractable key)		●	●	●	●
Roll Stability Control (RSC)		●	●	●	●
Seat-belt warning audible and visual (driver)		●	●	●	●
Seat-belt warning audible and visual (front passenger)		–	●	●	●
Seat-belts 3-point lap-sash (all seats)		●	●	●	●
Seat-belts (front) with: height adjustable shoulder anchorages		–	–	●	●
Seat-belts (front) with: pretensioners and load limiters		●	●	●	●
Side impact door beams		●	●	●	●
Traction Control System (TCS)		●	●	●	●
Trailer Sway Control (TSC)		●	●	●	●

4x4 SPECIFICATIONS

	4x4 Single Cab Chassis GLX	4x4 Freestyle Cab GLX	4x4 Freestyle Cab Chassis GLX Plus	4x4 Double Cab Chassis GLX	4x4 Double Cab GLX	4x4 Double Cab GSX	4x4 Double Cab Limited
--	----------------------------	-----------------------	------------------------------------	----------------------------	--------------------	--------------------	------------------------

Powertrain

Engine type	3.2 litre in-line 5 cylinder 20 valve DOHC intercooled turbo diesel							
Engine capacity	3,198 cc							
Bore and stroke	89.0 mm x 100.7 mm							
Compression ratio	15.5 : 1							
Maximum power	147 kW @ 3,000 rpm							
Maximum torque	470 Nm @ 1,750 – 2,500 rpm							
Throttle control	Electronic (drive-by-wire)							
Fuel system	Common-rail, electronic direct injection							
Fuel tank capacity	80 litres							
Recommended fuel	Diesel							
Fuel consumption ¹	man (combined)	8.9 litres per 100 km					-	
	auto (combined)	-	-	-	-	9.2 litres per 100 km	9.2 litres per 100 km	9.2 litres per 100 km
Emissions standard	Euro stage IV							
Alternator	12 volts - 110 amps							
Manual transmission	6-speed							
Automatic transmission	-	-	-	-	6-speed	6-speed	6-speed	
Gear ratio - man/auto	1st	5.441 / -	5.441 / -	5.441 / -	5.441 / -	5.441 / 4.171	5.441 / 4.171	- / 4.171
	2nd	2.839 / -	2.839 / -	2.839 / -	2.839 / -	2.839 / 2.342	2.839 / 2.342	- / 2.342
	3rd	1.721 / -	1.721 / -	1.721 / -	1.721 / -	1.721 / 1.521	1.721 / 1.521	- / 1.521
	4th	1.223 / -	1.223 / -	1.223 / -	1.223 / -	1.223 / 1.143	1.223 / 1.143	- / 1.143
	5th	1.000 / -	1.000 / -	1.000 / -	1.000 / -	1.000 / 0.867	1.000 / 0.867	- / 0.867
	6th	0.794 / -	0.794 / -	0.794 / -	0.794 / -	0.794 / 0.691	0.794 / 0.691	- / 0.691
	reverse	4.935 / -	4.935 / -	4.935 / -	4.935 / -	4.935 / 3.403	4.935 / 3.403	- / 3.403
	final drive	3.550 / -	3.550 / -	3.550 / -	3.550 / -	3.550 / 3.730	3.550 / 3.730	- / 3.730
Transfer gear	high	1.000	1.000	1.000	1.000	1.000	1.000	1.000
	low	2.718	2.718	2.718	2.718	2.718	2.718	2.718

Chassis

Brake diameter	front	302 mm						
	rear	295 mm						
Brake type	front	Ventilated disc						
	rear	Drum						
Steering type	Rack and pinion hydraulic power assist steering							
Suspension type	front	Independent double wishbone with coil over dampers and anti-roll bar						
	rear	Rigid (live) rear axle with leaf springs						
Turning circle	kerb to kerb	12.4 m						
Tyre size		255/70 R16	255/70 R16	265/65 R17	255/70 R16	255/70 R16	265/65 R17	265/65 R17
Tyre index		111T	111T	112T	111T	111T	112T	112T
Wheel size		16 x 7.0 J	16 x 7.0 J	17 x 8.0 J	16 x 7.0 J	16 x 7.0 J	17 x 8.0 J	17 x 8.0 J
Wheel type		Steel	Steel	Alloy	Steel	Steel	Alloy	Alloy
Wheel size (spare)		16 x 7.0 J	16 x 7.0 J	17 x 7.5 J	16 x 7.0 J	16 x 7.0 J	17 x 7.5 J	17 x 7.5 J
Wheel type (spare)		Steel	Steel	Steel	Steel	Steel	Steel	Steel

Weights and Capacities

Axle capacity	front	1,480 kg	1,480 kg	1,480 kg	1,480 kg	1,480 kg	1,480 kg	1,480 kg
	rear	1,850 kg	1,850 kg	1,850 kg	1,850 kg	1,850 kg	1,850 kg	1,850 kg
Gross Combined Mass (GCM) ²	man	5,950 kg	5,950 kg	5,950 kg	5,950 kg	5,950 kg	5,950 kg	-
	auto	-	-	-	-	5,950 kg	5,950 kg	5,950 kg
Gross Vehicle Mass (GVM)	man	3,200 kg	3,200 kg	3,200 kg	3,200 kg	3,200 kg	3,200 kg	-
	auto	-	-	-	-	3,200 kg	3,200 kg	3,200 kg
Kerb weight	man	1,788 kg	1,856 kg – 1,998 kg	1,885 kg	1,935 kg	2,059 kg	2,082 kg	-
	auto	-	-	-	-	2,061 kg	2,096 kg	2,105 kg
Payload ³	man	1,411 kg	1,343 kg	1,163 kg	1,271 kg	1,156 kg	1,114 kg	-
	auto	-	-	-	-	1,139 kg	1,097 kg	1,088 kg
Seating capacity		3	4	4	5	5	5	5
Tow ball download	maximum	235 kg	235 kg	235 kg	235 kg	235 kg	235 kg	235 kg
Towing capacity ²	braked	3,500 kg	3,500 kg	3,500 kg	3,500 kg	3,500 kg	3,500 kg	3,500 kg
	unbraked	750 kg	750 kg	750 kg	750 kg	750 kg	750 kg	750 kg

	A 4x4 Single Cab Chassis GLX	B,C 4x4 Freestyle Cab GLX	B 4x4 Freestyle Cab Chassis GLX Plus	D 4x4 Double Cab Chassis GLX	E 4x4 Double Cab GLX	F 4x4 Double Cab GSX	G 4x4 Double Cab Limited
--	---------------------------------	------------------------------	---	---------------------------------	-------------------------	-------------------------	-----------------------------

Dimensions

Cargo box floor height to ground	-	835 mm (utility)	-	-	835 mm	841 mm	841 mm
Cargo box floor length	-	1,847 mm (utility)	-	-	1,549 mm	1,549 mm	1,549 mm
Cargo box floor width	-	1,560 mm (utility)	-	-	1,560 mm	1,560 mm	1,560 mm
Cargo box height	-	513 mm (utility)	-	-	513 mm	513 mm	513 mm
Cargo box tailgate opening width	-	1,330 mm (utility)	-	-	1,330 mm	1,330 mm	1,330 mm
Cargo box top length	-	1,783 mm (utility)	-	-	1,485 mm	1,485 mm	1,485 mm
Cargo box top width	-	1,500 mm (utility)	-	-	1,500 mm	1,500 mm	1,500 mm
Cargo box width between wheel arches	-	1,139 mm (utility)	-	-	1,139 mm	1,139 mm	1,139 mm
Ground clearance	laden	200 mm	200 mm	205 mm	200 mm	205 mm	205 mm
	unladen	232 mm	232 mm	232 mm	232 mm	237 mm	237 mm
Overall length		5,124 mm	5,124 mm - 5,373 mm	5,124 mm	5,124 mm	5,373 mm	5,365 mm
Overall width		1,850 mm	1,850 mm	1,850 mm	1,850 mm	1,850 mm	1,850 mm
Overall height		1,800 mm	1,804 mm - 1,856 mm	1,804 mm	1,815 mm	1,837 mm	1,821 mm
Overhang	front	919 mm	919 mm	919 mm	919 mm	919 mm	919 mm
	rear	985 mm	985 mm - 1,234 mm	985 mm	985 mm	1,234 mm	1,226 mm
Track	front	1,560 mm	1,560 mm	1,560 mm	1,560 mm	1,560 mm	1,560 mm
	rear	1,560 mm	1,560 mm	1,560 mm	1,560 mm	1,560 mm	1,560 mm
Wading depth		800 mm	800 mm	800 mm	800 mm	800 mm	800 mm
Wheelbase		3,220 mm	3,220 mm	3,220 mm	3,220 mm	3,220 mm	3,220 mm
Approach angle		27.6°	27.6°	27.6°	27.6°	27.6°	28.2°
Departure angle		28.4°	28.4°	28.4°	28.4°	27.1°	26.4°
Ramp breakover angle		24.4°	24.4°	24.4°	24.4°	25.0°	25.0°

CAB CHASSIS

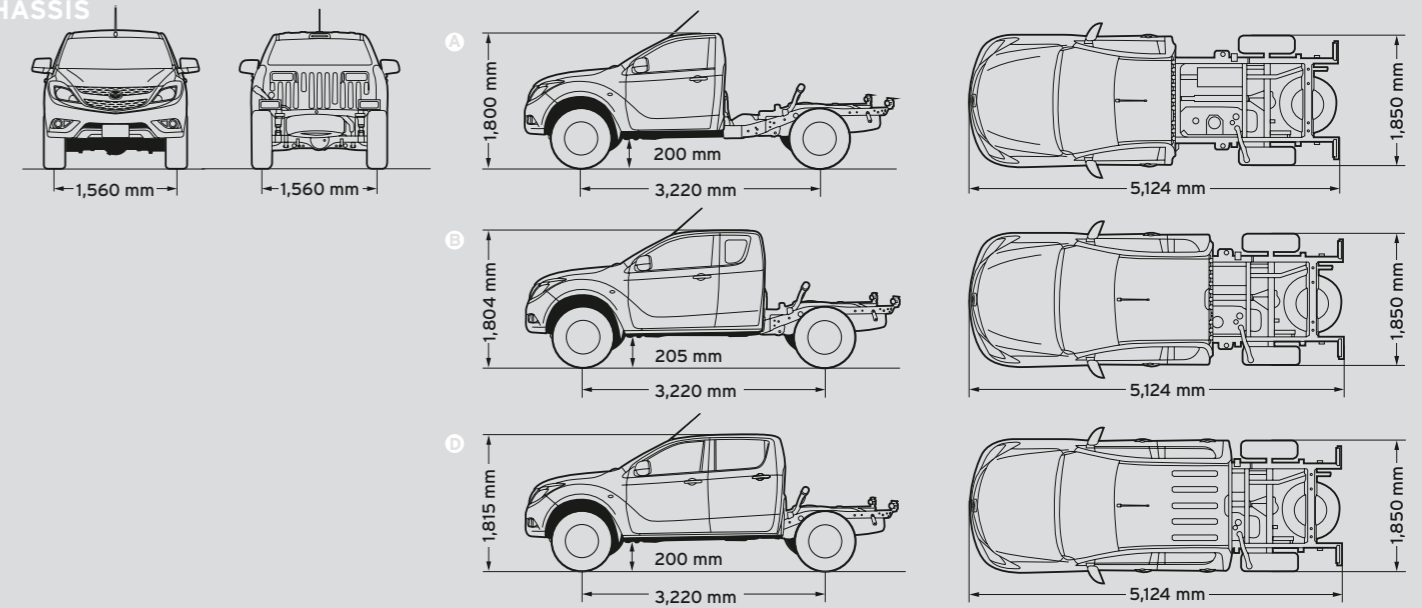

UTILITY

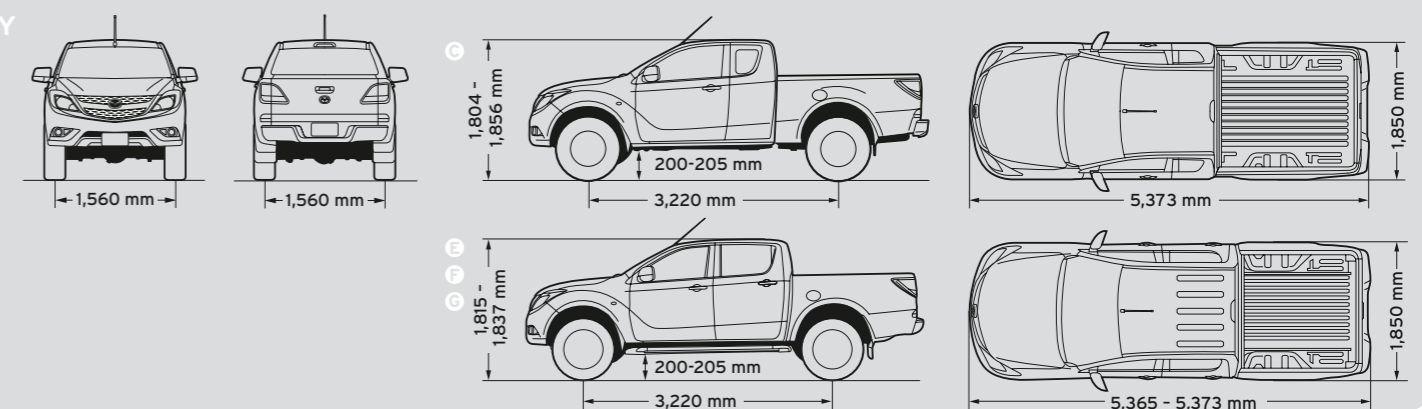

● Standard Feature – Not Available ● No Cost Option

4x4 SPECIFICATIONS

	4x4 Single Cab Chassis GLX	4x4 Freestyle Cab GLX	4x4 Freestyle Cab Chassis GLX Plus	4x4 Double Cab Chassis GLX	4x4 Double Cab GLX	4x4 Double Cab GSX	4x4 Double Cab Limited
--	----------------------------	-----------------------	------------------------------------	----------------------------	--------------------	--------------------	------------------------

Exterior

Cargo box features:	centre tailgate release (black)	–	Utility	–	–	•	–
	centre tailgate release (chrome)	–	–	–	–	•	•
	double wall construction	–	Utility	–	–	•	•
	interior rope hooks (6)	–	Utility	–	–	•	•
Door handles (black)	•	•	–	•	•	–	–
Door handles (chrome)	–	–	•	–	–	•	•
Fog-lamps (front)	–	–	–	–	–	•	•
Freestyle door system	–	•	•	–	–	–	–
Front bumper (body coloured)	•	•	•	•	•	•	•
Fuel filler cap (lockable)	• (with key for C/C)	• (with key for C/C)	• (with key for C/C)	• (with key for C/C)	•	•	•
Green tinted windscreen, side and rear windows	•	•	•	•	•	•	•
Headlamps (halogen)	•	•	•	•	•	•	•
Metallic/Mica paint	•	•	•	•	•	•	•
Mudflaps (front)	•	•	•	•	•	•	•
Mudflaps (rear)	–	Utility	–	–	•	•	•
Power mirrors (black)	•	•	–	•	•	–	–
Power mirrors (chrome)	–	–	•	–	–	•	•
Power windows	•	•	•	•	•	•	•
Rear step bumper (black)	–	Utility	–	–	•	–	–
Rear step bumper (chrome)	–	–	–	–	–	•	•
Side steps (aluminium finish)	–	–	•	–	–	•	•
Under-body impact protection	•	•	•	•	•	•	•

Interior

Air-conditioning	•	•	•	•	•	•	–
Air-conditioning (dual-zone climate control)	–	–	–	–	–	• ⁶	•
Ambient temperature gauge	–	–	–	–	–	–	•
Auxiliary 12 volt power outlets	•	•	•	•	•	•	•
Bluetooth® (hands-free compatible) ⁴	•	•	•	•	•	•	•
Centre armrest console with dual compartments	–	•	•	•	•	•	•
Critical function warning lights/chimes	•	•	•	•	•	•	•
Cruise control	•	•	•	•	•	•	•
Cupholders	•	•	•	•	•	•	•
Door pockets	•	•	•	•	•	•	•
Driver's left footrest	•	•	•	•	•	•	•
Floor covering:	carpet	–	–	–	–	•	•
	vinyl	•	•	•	•	–	–
Glove box	•	•	•	•	•	–	–
Glove box (lockable and illuminated)	–	–	–	–	–	•	•
Headlamps auto on/off function	–	–	–	–	–	–	•
Illuminated entry system with delayed fade	•	•	•	•	•	•	•
Instrument panel light dimmer	•	•	•	•	•	•	•
Interior illumination:	dome lamp	–	•	•	•	•	•
	map reading spot lamps	•	•	•	•	•	•
	power window switch (driver)	•	•	•	•	•	•
Leather-wrapped:	gear shift knob	–	–	–	–	•	•
	steering wheel	–	–	–	–	•	•
Low fuel warning light	•	•	•	•	•	•	•
Overhead sunglass storage box	•	•	•	•	•	•	•
Passenger assist grips	•	•	•	•	•	•	•
Rear-view mirror with auto dimming function	–	–	–	–	–	–	•
Seat trim:	cloth	•	•	•	•	•	–
	leather ⁵	–	–	–	–	–	•
Seat (driver's bucket) with:	adjustable head restraint	•	•	•	•	•	•
	height and lumbar adjustment	–	–	–	–	•	•
	rake and slide adjustment	•	•	•	•	•	•
Seat (passengers' front bench) with:	adjustable head restraint	•	–	–	–	–	–

	4x4 Single Cab Chassis GLX	4x4 Freestyle Cab GLX	4x4 Freestyle Cab Chassis GLX Plus	4x4 Double Cab Chassis GLX	4x4 Double Cab GLX	4x4 Double Cab GSX	4x4 Double Cab Limited
--	----------------------------	-----------------------	------------------------------------	----------------------------	--------------------	--------------------	------------------------

Interior (continued)

Seat (passengers' front bucket) with:	–	•	•	•	•	•	•
	adjustable head restraint	–	•	•	•	•	•
	rake and slide adjustment	–	•	•	•	•	•
	seat back pocket	–	•	•	•	•	•
Seat (passengers' rear bench) with:	–	–	–	•	•	•	•
	adjustable head restraints	–	–	–	•	•	•
	foldable seat base and under-seat storage	–	–	–	•	•	•
Seat (passengers' rear jump) with:	–	•	•	–	–	–	–
	removable seat base and under-seat storage	–	•	•	–	–	–
Tachometer and electronic odometer/tripmeter	•	•	•	•	•	•	•
Tilt-adjustable steering wheel	•	•	•	•	•	•	•
Trip computer (current and average fuel consumption, distance to empty and average vehicle speed)	•	•	•	•	•	•	•
Vanity mirror (front passenger)	•	•	•	•	•	•	•
Window demister (rear)	•	•	•	•	•	•	•
Wipers (front) 2-speed with rain-sensing function	–	–	–	–	–	–	•
Wipers (front) 2-speed with variable intermittent function	•	•	•	•	•	•	–

Audio

AM/FM tuner	•	•	•	•	•	•	•
Auxiliary input (3.5mm MP3 player compatible)	•	•	•	•	•	•	•
Bluetooth® audio (MP3 player compatible)	•	•	•	•	•	•	•
CD player, single disc (MP3/WMA compatible)	•	•	•	•	•	•	•
Speakers (4)	•	–	–	–	–	–	–
Speakers (6)	–	•	•	•	•	•	•
Steering wheel-mounted audio controls	•	•	•	•	•	•	•
USB input (iPod compatible)	•	•	•	•	•	•	•

Safety

5-Star ANCAP safety rating	•	•	•	•	•	•	•
Airbags SRS:	front (driver and passenger)	•	•	•	•	•	•
	side (front)	–	•	•	•	•	•
	curtain (front)	•	–	–	–	–	–
	curtain (front and rear)	–	•	•	•	•	•
Anti-lock Braking System (ABS)	•	•	•	•	•	•	•
Child restraint anchor points (2)	–	•	•	•	•	•	•
Childproof rear door locks	–	–	–	•	•	•	•
Dynamic Stability Control (DSC) - switchable on/off	•	•	•	•	•	•	•
Electronic Brake-force Distribution (EBD)	•	•	•	•	•	•	•
Emergency Brake Assist (EBA)	•	•	•	•	•	•	•
Engine immobiliser	•	•	•	•	•	•	•
Emergency Stop Signal (ESS)	•	•	•	•	•	•	•
High mount stop lamp	–	Utility	–	–	•	•	•
Hill Descent Control (HDC)	•	•	•	•	•	•	•
Hill Launch Assist (HLA)	•	•	•	•	•	•	•
Intrusion-minimising brake pedal	•	•	•	•	•	•	•
Left-hand-side convex (wide angle) exterior mirror	•	•	•	•	•	•	•
Load Adaptive Control (LAC)	•	•	•	•	•	•	•
Locking Rear Differential (LRD) - switchable on/off	•	•	•	•	•	•	•
One touch (up and down) power window (driver)	•	•	•	•	•	•	•
Remote central locking (2 transmitters with retractable key)	•	•	•	•	•	•	•
Roll Stability Control (RSC)	•	•	•	•	•	•	•
Seat-belt warning audible and visual (driver)	•	•	•	•	•	•	•
Seat-belt warning audible and visual (front passenger)	–	•	•	•	•	•	•
Seat-belts 3-point lap-sash (all seats)	•	•	•	•	•	•	•
Seat-belts (front) with: height adjustable shoulder anchorages	–	–	–	•	•	•	•
Seat-belts (front) with: pretensioners and load limiters	•	•	•	•	•	•	•
Side impact door beams	•	•	•	•	•	•	•
Traction Control System (TCS)	•	•	•	•	•	•	•
Trailer Sway Control (TSC)	•	•	•	•	•	•	•

• Standard Feature – Not Available • No Cost Option



THE ACTIVE LIFESTYLE VEHICLE A NEW APPROACH TO UTILITY DESIGN

The latest Mazda BT-50 represents a bold departure from traditional utility design. We wanted its enhanced versatility to appeal to families, and people with active lifestyles. So we infused BT-50 with a highly dynamic presence, one that captures Mazda's sporting DNA. Chief Designer Ryo Yanagisawa expands: 'We drew inspiration from movement in the world around us. For example, we had a photograph of a lion. He looked like a magnificent predator about to pounce on his prey. It appeared both intelligent and powerful and I wanted the design to project that kind of image.' With the sort of distinctive sophistication you can appreciate in Mazda passenger cars, the latest BT-50 is a fresh direction. One that lets you enjoy Zoom-Zoom, no matter what you're doing.

Mazda commercialcare - 3 years of caring for your vehicle at no extra cost

Every new Mazda BT-50 comes with Mazda commercialcare included. This comprehensive cover includes 3 years of Mazda On Call Roadside Assistance plus 3 years or 150,000km (whichever occurs first) of a comprehensive Mazda Warranty at no extra cost. It also entitles you to 3 years or 100,000km (whichever occurs first) of Fixed Price Servicing. Find out more below and at mazda.co.nz/mazda-commercialcare

Maintain that Zoom-Zoom for no more than \$200 per service⁶

Regular servicing is good because it keeps your Mazda in great shape for longer, saving you money in fuel, parts and keeps your vehicle safer on the road. That's why we offer 3 years or 100,000km (whichever occurs first) of Fixed Price Servicing as part of Mazda commercialcare. This means you pay no more than \$200 (incl. GST) per service at scheduled service intervals every 6 months or 10,000km (whichever comes first). Of course, each service will be carried out by Mazda factory-trained Service Specialists using the latest in

vehicle diagnostic equipment, in order to keep your BT-50 operating at optimum driving performance.

Help is at hand - Mazda Roadside Assistance

If something goes wrong when you're travelling then we're here to help. Mazda On Call is a roadside assistance programme available to Mazda owners 24-hours a day, 365 days a year - included as part of your Mazda commercialcare cover. So, if you run out of fuel, lock your keys in the car or simply forget how to programme the stereo, all you need to do is call us. Our support centres are ready to help out with any mechanical, medical and even legal advice you might need.

Accessories add enjoyment

Mazda BT-50 combines amazing versatility with refined design. And with Mazda Genuine Accessories, owning one becomes even more satisfying. They let you personalise your vehicle and protect your investment. They also deliver superb design, quality, fit and safety. Mazda Genuine Accessories let you add even more Zoom-Zoom.

COLOURS

Exterior

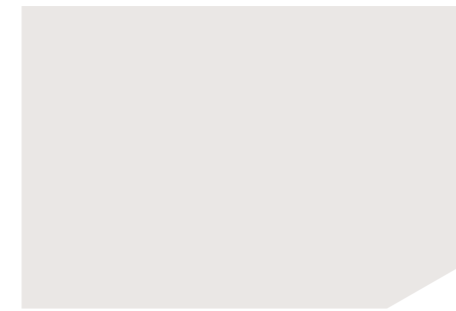

Cool White



Highlight Silver
Metallic



Titanium Grey
Metallic



Sparkling Gold
Mica



Gunmetal Blue
Mica



Aurora Blue
Metallic



Copper Red
Mica



Black
Mica

Interior



Black Cloth
GLX



Black Cloth
GSX



Black Leather⁵
Limited

All care is taken to ensure the accuracy of this brochure at the time of publication. Specifications, features and model availability may vary from dealer to dealer and may change without notice. Please refer to mazda.co.nz or consult your Mazda dealer prior to placing an order to ascertain current information on model availability, specifications, options, features and prices. Mazda Motors of New Zealand Limited will not be liable for any loss arising from the information in this brochure, whether in negligence or otherwise. Mazda Motors of New Zealand Limited, PO Box 132 057, Sylvia Park, Auckland 1644. Due to the nature of the printing process, colours may vary from those shown in this brochure. Ask your dealer to show you a product sample. Published June 2013. MZ4900521.

¹ Fuel consumption figures are based on ADR81/02. They are useful in comparing the fuel consumption of different vehicles. They may not be the fuel consumption achieved in practice. This will depend on traffic, road conditions and how the vehicle is driven. ² Gross Combined Mass (GCM) is the total permissible combined weight of the vehicle and trailer/caravan being towed including occupants, fuel and cargo. ³ The weight of any vehicle occupants, options, accessories, modifications, cargo and towball download must be included when calculating payload weight. ⁴ Please check the compatibility of your Bluetooth[®] device (particularly your mobile phone) with the specific Mazda vehicle you intend to purchase as not all devices operate correctly. Consult your Mazda dealer for further information. ⁵ Leather interior includes Maztex material on selected high impact surfaces. ⁶ Features available for vehicles produced from March 2012 onward. ⁷ 3,500kg braked towing capacity applies for BT-5C models manufactured from 1 November 2012, onward. ⁸ Mazda commercialcare Fixed Price Servicing is only available for BT5C models manufactured from August 2011 onward.



MX-5



Mazda 6



Mazda 3



BT-50



Mazda 2



CX-9



CX-5

zoom-zoom
zoom-zoom