

# MAZDA BT-50



*zoom-zoom*



**mazda**

# IMAGINATION DRIVES US

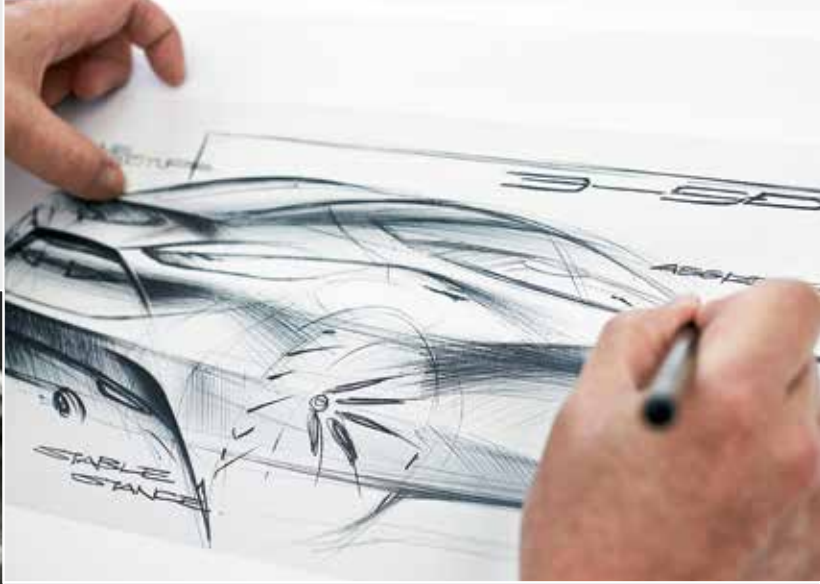

Imagination is the world's most valuable resource. It's our window to the future, because if we can imagine it, we can create it. Mazda is built on a foundation of imagination and ingenuity. It's the fuel behind all we create and achieve. It has given us countless successes that once existed only in someone's imagination. These pages show how imagination is an integral part of our innovative cars.

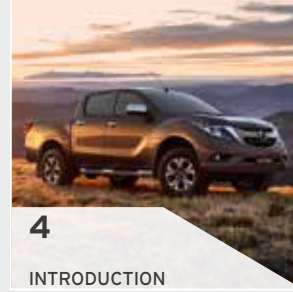

**4**  
INTRODUCTION



**6**  
EXTERIOR



**8**  
DYNAMICS



**10**  
PERFORMANCE



**12**  
UTILITIES



**14**  
SAFETY



**16**  
INTERIOR

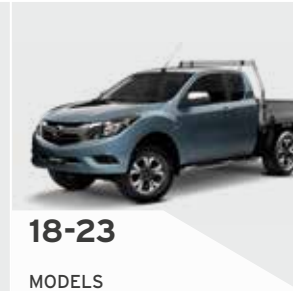

**18-23**  
MODELS



**24-31**  
SPECIFICATIONS



**32**  
TOWING & PAYLOAD



**34**  
CONFIDENCE

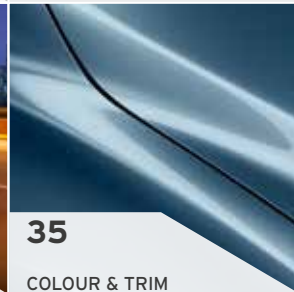

**35**  
COLOUR & TRIM

**BUILT TO DO IT ALL**

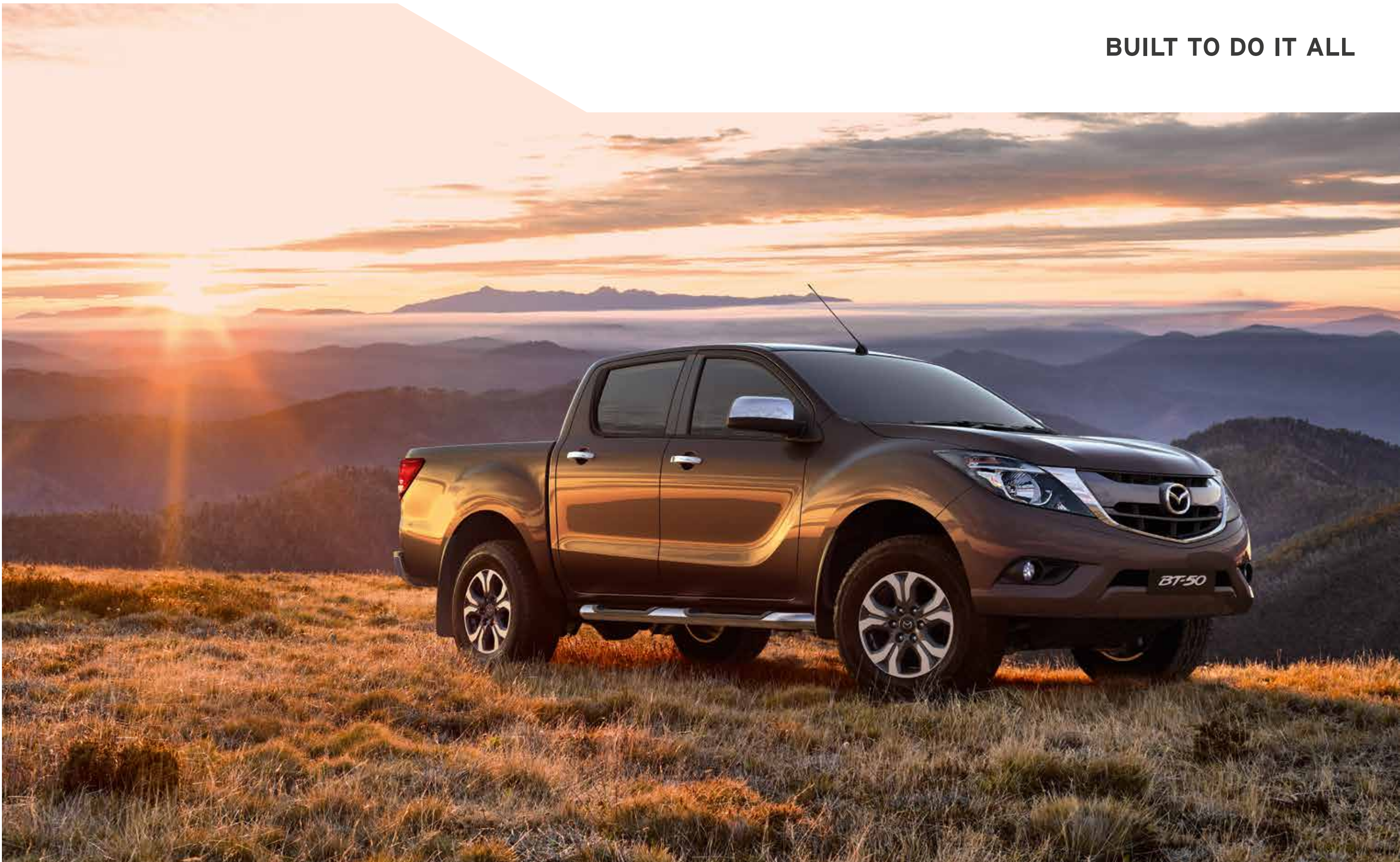

New BT-50 is built tough to take on any task, and do it in style. It delivers grunt when you need it, and refined comfort with every drive. Fill it with gear, pull a load or take it off road. As a workhorse or a weekend warrior, it's always up to the challenge.

Smart connectivity, navigation and driver aids mean BT-50 is clever as well as capable. The spacious cabin is a stylish surprise, with a level of passenger comfort that makes it feel more like a car. And it's all protected with advanced safety features like airbags and Dynamic Stability Control.

Equipped for work, play and everything in between, BT-50 can do it all - with added Zoom-Zoom.

4x4 Double Cab Wellside GSX in Titanium Flash Mica.

## POWERFUL YET REFINED



When it comes to New BT-50, looks are just the beginning. Built for fun as much as it is for hard work, the exterior is bold and adventurous. With its refined features, it's a cut above others in its class.

Styled with tough lines to match its solid capabilities, the bold new front is strong and powerful, for a commanding street presence. The slightly lowered angle toward the front gives it a sense of forward motion - and the perfect balance of strong and sleek.



4x4 Double Cab Wellside GSX in Titanium Flash Mica.

BRING IT ON



When it comes to performance, New BT-50 brings the goods. Built tough from the ground up, its ladder-frame chassis provides reinforcement for maximum rigidity. The resulting stability can be felt in car-like handling, while the powerful engine makes towing light work. Speaking of towing, BT-50 is capable of pulling an impressive 3,500kg<sup>†</sup>

Powered by new generation turbo diesel engines, you get more muscle from less fuel. Harnessing the power is up to you - choose from a rugged 6-speed Manual for complete control, or a versatile 6-speed Auto that also allows for smooth and intuitive gear changes.

4x4 Freestyle Cab GSX in Blue Reflex Mica with optional tray fitted.

# A GUTSY PERFORMANCE EVERY TIME



## 3.2L DIESEL ENGINE

Feel the power of a five-cylinder engine with common-rail direct injection and intercooling. Pumping out 147kW and 470Nm of torque from just 8.9 litres per 100km<sup>2</sup> (combined), you get power and efficiency together.



## LOCKING REAR DIFFERENTIAL (LRD)

Standard across all models, the LRD maximises off-road grip by locking the rear wheels so both receive the same amount of torque. So even when one wheel has lost traction, the other provides drive.



## AUTOMATIC TRANSMISSION

Let the intelligent 6-speed Auto do the work for you, or step in for Manual gear shifts when the mood strikes. In Auto mode, Active Adaptive Shift (AAS) kicks in - intuitively changing gears to suit your driving conditions.



## MANUAL TRANSMISSION

Enjoy the smooth ride of a 6-speed Manual that delivers fluid precision-shifting ratios. Transition through gear changes with ease for a true sense of control over your vehicle's performance.

Make the most of generous power without the thirstiness you expect. New BT-50 comes with superior performance and fuel efficiency - perfect for those weekend getaways.

Take on the toughest tasks effortlessly, thanks to advanced common-rail direct injection. Boosted by a lag-reducing variable geometry turbocharger, the punchy 3.2 litre engine gives you 147kW of power and a whopping 470Nm of torque to easily overpower any challenge.

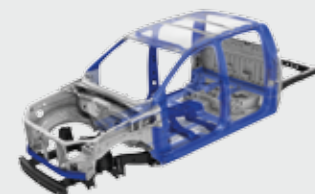

## BODY

High-tensile steel is behind the BT-50's durable body shell. Exceptionally strong, it also keeps overall weight down.



## CHASSIS

Reinforced with a rigid ladder frame chassis, BT-50 is ready to take on the heavy-duty jobs. Front wishbone suspension and rear leaf suspension cushion the ride for car-like handling on and off the road.

# THE STRENGTH TO TAKE ON ANY CHALLENGE

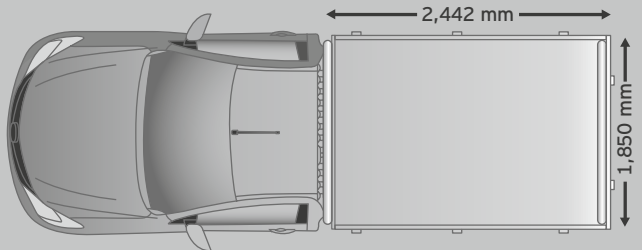

Single Cab (Chassis)

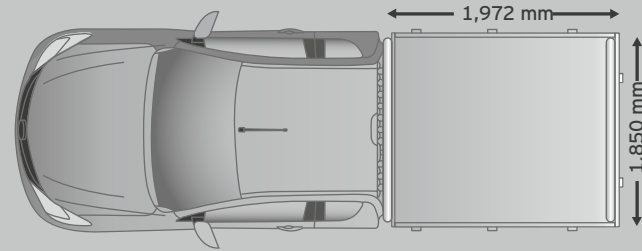

Freestyle Cab (Chassis)

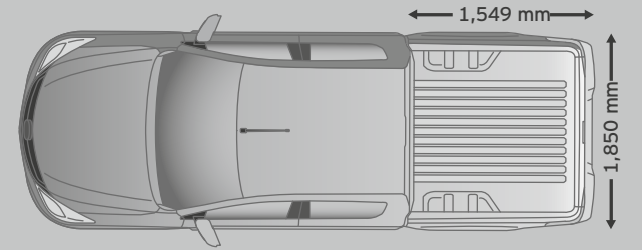

Double Cab (Wellside)

Equipped with power and backbone, BT-50 has an enviable towing capacity of up to 3,500kg<sup>4</sup>. Don't be afraid to give it heaps - depending on the model, it has the capacity to take on payloads of up to 1,506kg<sup>5</sup>. Venture off the beaten track with the rugged 4x4. Backed by the latest driver support tech, uneven terrain has never been easier to conquer. Jump between 2-High and 4-High at the flick of a switch, without stopping the vehicle.

Operated via a console switch, electronic Locking Rear Differential (eLRD) gives you maximum traction on uneven terrain. By locking the rear wheels, torque is distributed evenly between them. If one wheel loses grip, the other continues to provide power, turning the wheel to get traction on the ground.

<sup>4</sup>4x4 Double Cab Wellside GSX in Titanium Flash Mica with optional tow bar fitted.

# THE CONFIDENCE OF FULL PROTECTION

Feel confident driving a vehicle that's big on safety.

Driver support begins with a rigid ride and accurate handling, giving you the capacity to avoid potential hazards. In the event BT-50 does run into trouble, it's well equipped to deal with it. The reinforced body shell is fitted with front airbags and head-protecting curtain airbags in all models. Freestyle and Double Cab models also come with the addition of side (front) airbags. And all seats feature three-point lap-sash seatbelts.

In 4x4 models, Hill Descent Control (HDC) automatically applies brakes to maintain a steady, low speed down steep slopes. Control is greatly enhanced, particularly in off-road conditions.

Roll Stability Control (RSC) monitors your driving data and applies appropriate measures to help prevent rollover. And when your cargo raises BT-50's centre of gravity, you've got Load Adaptive Control (LAC) for extra stability.

Dynamic Stability Control (DSC) helps keep traction in all conditions, managing the engine power and braking force delivered to individual wheels to avoid skidding or loss of grip.

ABS brakes feature Electronic Brake-force Distribution (EBD) which matches braking to vehicle load, while Emergency Brake Assist (EBA) boosts stopping power when emergency braking is sensed. An Emergency Stop Signal (ESS) activates the hazard lights to warn following drivers of sudden deceleration.



4x4 Double Cab Wellside GSX in Titanium Flash Mica.

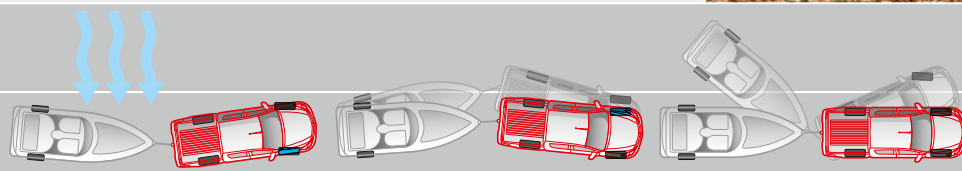

## SAFETY REFLEX

Trailer Sway Control (TSC) adjusts braking and torque to correct any side-to-side swinging movement of towed loads.



## BETTER BRAKING

Stopping distance with EBA, ABS and EBD.



Stopping distance with no assistance.



## INCLINES MADE EASY

Remove your foot from the brake on an incline and Hill Launch Assist (HLA) keeps the brakes applied, releasing them when there's enough power for a smooth start. While you're on steep slopes, Hill Descent Control (HDC) kicks in to maintain steady control of your speed.

## A CUT ABOVE



Whether it's power, strength or capability, New BT-50 consistently delivers more.

With all the refinement of a car, New BT-50 makes it hard to believe you're in a ute. The interior is appointed with quality trims and finishes, while powerful heating and cooling provides comfort all year round, including dual-zone climate control (GSX and Limited models).

Enjoy clever thinking with useful driver technology, like trip computer, cruise control and wireless connectivity across the range, as well as satellite navigation in GSX and Limited models. Control it all safely from the steering wheel. Crank up the thumping 6-speaker audio system, including a CD player that hosts MP3 and WMA playback. The unit is also USB and Bluetooth® compatible, so you can make and answer phone calls with built-in hands-free connectivity!

When it comes to space, you'll be surprised how much smart storage can be found around the cabin. Tuck your gear away in the split-level centre console space, or the sizeable glovebox that swallows a 16-inch laptop. Drinks and sunnies have their own dedicated spaces, keeping them within grabbing reach on every trip.

4x4 Double Cab Wellside GSX Automatic.

# Mazda BT-50

SINGLE CAB



4x2 Single Cab Chassis GLX in Cool White (with optional tray).



4x2 Single Cab Chassis GLX with Black Cloth in Aluminium Metallic.

## SINGLE CAB features include:

### GLX

- 16-inch steel wheels with 255/70 tyres
- Headlamps (Halogen)
- Power windows and mirrors (black)
- Seat trim: Black cloth
- Air-conditioning
- Cruise control
- Lockable and illuminated glovebox
- Trip computer<sup>7</sup>
- 3.5-inch multi-information display
- Audio system with: AM/FM tuner, single-disc CD player (MP3 compatible) and 4 speakers
- Bluetooth® hands-free phone and audio capability<sup>1</sup>
- USB input iPod compatible
- Steering wheel-mounted audio controls
- Floor Covering: Vinyl
- Airbags SRS: front (driver and passenger) and curtain (driver and passenger)
- Anti-lock Braking System (ABS)
- Dynamic Stability Control (DSC)
- Emergency Stop Signal (ESS)
- Hill Descent Control (HDC) - 4x4 only
- Hill Launch Assist (HLA)
- Locking Rear Differential (LRD)
- Roll Stability Control (RSC)
- Traction Control System (TCS)
- Trailer Sway Control (TSC)

### GLX Wellside Model

(Special order only - 2WD only)

#### Includes:

- Cargo box
- Rear step bumper (chrome)
- Ladder rack
- Tailgate (lockable)
- Mudflaps (rear)
- Parking sensors (rear)

## Powertrain:

- 3.2 litre in-line 5 cylinder 20 valve DOHC intercooled turbo diesel engine
- Drivetrain: 4x2 or 4x4
- Max power: 147kW @ 3,000rpm
- Max torque: 470Nm @ 1,750-2,500rpm
- 6-speed Manual
- Fuel consumption (combined): 8.9L/100km<sup>2</sup> (4x2 Manual) 9.7L/100km<sup>2</sup> (4x4 Manual)



4x2 Chassis GLX



4x4 Chassis GLX

## GET COMFORTABLE

The single cab features a bucket seat for the driver and bench seating for two others - all finished in durable cloth trim.



## CONNECTIVITY ON THE MOVE

Make hands-free calls<sup>1</sup> and stream audio with built-in Bluetooth®



## KEEP INFORMED

Trip computer details useful information such as fuel economy, distance to empty and more.<sup>7</sup>

# Mazda BT-50

## FREESTYLE CAB



4x4 Freestyle Cab Chassis GSX in Blue Reflex Mica (with optional tray).

### FREESTYLE CAB features include:

#### GLX

- 16-inch steel wheels with 255/70 tyres
- Freestyle door system
- Headlamps (Halogen)
- Power windows and mirrors (black)
- Seat trim: Black cloth
- Floor covering: Vinyl
- Air-conditioning
- Cruise control
- Lockable and illuminated glovebox
- 8-way adjustable driver's seat
- Trip computer<sup>7</sup>
- 3.5-inch multi-information display
- Audio system with: AM/FM tuner, single-disc CD player (MP3 compatible) and 6 speakers
- Bluetooth® hands-free phone and audio capability<sup>1</sup>
- Steering wheel-mounted audio controls
- USB input iPod compatible
- Airbags SRS: front (driver and passenger), side (front) and curtain (front and rear)

- Anti-lock Braking System (ABS)
- Dynamic Stability Control (DSC)
- Emergency Stop Signal (ESS)
- Hill Descent Control (HDC) - 4x4 only
- Hill Launch Assist (HLA)
- Locking Rear Differential (LRD)
- Roll Stability Control (RSC)
- Traction Control System (TCS)
- Trailer Sway Control (TSC)

#### GLX Wellside Model

(Special order only - 2WD and 4WD)

#### Includes:

- Cargo box
- Rear step bumper (chrome)
- Ladder rack
- Tailgate (lockable)
- Mudflaps (rear)
- Parking sensors (rear)

#### GSX features additional to GLX include:

- 17-inch machined alloy wheels with 265/65 tyres
- Door handles (chrome)
- Front fog-lamps (Halogen)
- Headlamps auto on/off function
- Power mirrors (chrome)
- Side steps (tubular, aluminium finish)
- Wipers (front) 2-speed with rain-sensing function
- Air-conditioning (dual-zone climate control)
- Floor covering: Carpet
- Leather-wrapped steering wheel
- Rear-view mirror auto dimming
- Satellite navigation (with 3 years free map updates)
- Reversing Camera
- Seat Trim: Black sports cloth
- 7.8-inch full colour touchscreen display

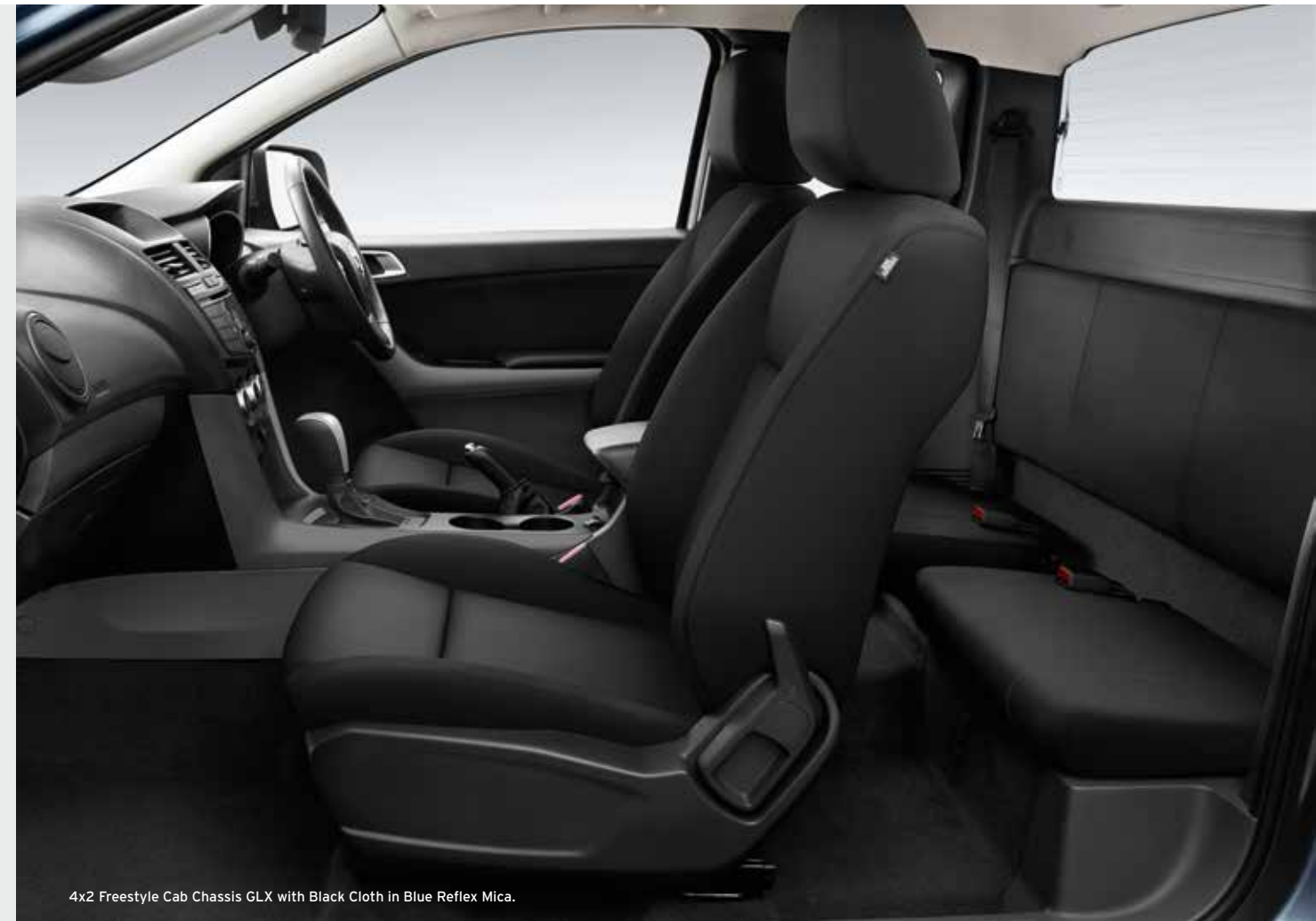

4x2 Freestyle Cab Chassis GLX with Black Cloth in Blue Reflex Mica.

### VERSATILITY AND DURABILITY

All seats are finished in quality cloth trim, and how they're configured is up to you.



### FREEDOM OF FLEXIBILITY

Open up your interior options with a versatile rear door configuration.

### SMOOTH CRUISIN'

Maintain a consistent speed and save fuel without the distraction of checking your speedometer.

### Powertrain:

- 3.2 litre in-line 5 cylinder 20 valve DOHC intercooled turbo diesel engine
- Drivetrain: 4x2 or 4x4
- Max power: 147kW @ 3,000rpm
- Max torque: 470Nm @ 1,750-2,500rpm
- 6-speed Automatic (with Manual mode)

- Fuel consumption (combined): 9.3L/100km<sup>2</sup> (4x2 Automatic) 10L/100km<sup>2</sup> (4x4 Automatic)



4x2 Chassis GLX



4x4 Chassis GLX



4x4 Chassis GSX

# Mazda BT-50

DOUBLE CAB



## DOUBLE CAB features include:

### GLX

- 16-inch steel wheels with 255/70 tyres
- Headlamps (Halogen)
- Power windows and mirrors (black)
- Rear step bumper (chrome)
- Lockable tailgate
- Seat trim: Black cloth
- Floor Covering: Vinyl
- Air-conditioning
- Cruise control
- 8-way adjustable driver's seat
- Lockable and illuminated glovebox
- Trip computer<sup>7</sup>
- 3.5-inch multi-information display
- Audio system with: AM/FM tuner, single-disc CD player (MP3 compatible) and 6 speakers
- Bluetooth® hands-free phone and audio capability<sup>1</sup>
- Steering wheel-mounted audio controls
- USB input iPod compatible
- Parking sensors (rear)
- Airbags SRS: front (driver and passenger), side (front) and curtain (front and rear)

- Anti-lock Braking System (ABS)
- Dynamic Stability Control (DSC)
- Emergency Stop Signal (ESS)
- Hill Descent Control (HDC) - 4x4 only
- Hill Launch Assist (HLA)
- Locking Rear Differential (LRD)
- Roll Stability Control (RSC)
- Traction Control System (TCS)
- Trailer Sway Control (TSC)

### GSX features additional to GLX include:

- 17-inch machined alloy wheels with 265/65 tyres
- Door handles (chrome)
- Front fog-lamps (Halogen)
- Headlamps auto on/off function
- Power mirrors (chrome)
- Side steps (tubular, aluminium finish)
- Wipers (front) 2-speed with rain-sensing function
- Air-conditioning (dual-zone climate control)
- Floor covering: Carpet
- Leather-wrapped steering wheel and gear shift knob

- Rear-view mirror auto dimming
- Satellite navigation (with 3 years free map updates)
- Reversing camera
- Seat Trim: Black sports cloth
- Centre armrest (rear seat)
- 7.8-inch full colour touchscreen display

### Limited features additional to GSX include:

- Power mirrors (heating and folding function) with turn indicator
- Privacy glass
- Front seats with: 8-way power adjustment (driver)
- Seat trim: Black leather<sup>9</sup>

4x4 Double Cab Wellside Limited in Deep Crystal Blue Mica.



4x2 Double Cab Wellside GSX with Black Sports Cloth in Aluminium Metallic.

## SPACE AND STYLE

Accommodate five adults comfortably in black cloth, black sports cloth or black leather.



## REVERSING CAMERA

Equipped to GSX and Limited models, the reversing camera is a great help. The view behind is automatically displayed when you reverse, making backing-up safer and easier.

## THIS WAY

In-built satellite navigation (with 3 years free map updates) on GSX and Limited models leads the way, so you can relax and enjoy the ride.

## Powertrain:

- 3.2 litre in-line 5 cylinder 20 valve DOHC intercooled turbo diesel engine
- Drivetrain: 4x2 or 4x4
- Max power: 147kW @ 3,000rpm
- Max torque: 470Nm @ 1,750-2,500rpm
- 6-speed Automatic (with Manual mode) or 6-speed Manual

- Fuel consumption (combined): 8.9L/100km<sup>2</sup> (4x2 Manual)
- 9.3L/100km<sup>2</sup> (4x2 Automatic)
- 9.7L/100km<sup>2</sup> (4x4 Manual)
- 10L/100km<sup>2</sup> (4x4 Automatic)



4x2 Wellside GLX



4x4 Wellside GLX



4x2 Wellside GSX



4x4 Wellside GSX/Limited

# SPECIFICATIONS

## 4x2

Powertrain		3.2L Single Cab Chassis GLX	3.2L Freestyle Cab Chassis GLX	3.2L Double Cab Wellside GLX	3.2L Double Cab Wellside GSX
Engine type		3.2 litre in-line 5 cylinder 20 valve DOHC intercooled turbo diesel			
Engine capacity		3,198 cc			
Bore and stroke		89.0 mm x 100.7 mm			
Compression ratio		15.5 : 1			
Maximum power		147kW @ 3,000rpm			
Maximum torque		470Nm @ 1,750-2,500rpm			
Throttle control		Electronic (drive-by-wire)			
Fuel system		Common-rail, electronic direct injection			
Fuel tank capacity		80 litres			
Recommended fuel		Diesel			
Fuel consumption (l/100km) <sup>2</sup>	man (combined)	8.9	-	8.9	8.9
	auto (combined)	-	9.3	9.3	9.3
Emissions standard		Euro stage V			
Alternator		12 volts - 110 amps			
Manual transmission		6-speed	-	6-speed	6-speed
Automatic transmission		-	6-speed	6-speed	6-speed
Gear ratio - man/auto	1st	5.441 / -	- / 4.171	5.441 / 4.171	5.441 / 4.171
	2nd	2.839 / -	- / 2.342	2.839 / 2.342	2.839 / 2.342
	3rd	1.721 / -	- / 1.521	1.721 / 1.521	1.721 / 1.521
	4th	1.223 / -	- / 1.143	1.223 / 1.143	1.223 / 1.143
	5th	1.000 / -	- / 0.867	1.000 / 0.867	1.000 / 0.867
	6th	0.794 / -	- / 0.691	0.794 / 0.691	0.794 / 0.691
	reverse	4.935 / -	- / 3.403	4.935 / 3.403	4.935 / 3.403
	final drive	3.550 / -	- / 3.730	3.550 / 3.730	3.550 / 3.730

Chassis					
Brake diameter	front	302 mm			
	rear	270 mm			
Brake type	front	Ventilated disc			
	rear	Drum			
Steering type		Rack and pinion hydraulic power assist steering			
Suspension type	front	Independent double wishbone with coil over dampers and anti-roll bar			
	rear	Rigid (live) rear axle with leaf springs			
Turning circle	kerb to kerb	12.4 m			
Tyre size		255/70 R16	255/70 R16	255/70 R16	265/65 R17
Tyre index		111T	111T	111T	112T
Wheel size		16 x 7.0 J	16 x 7.0 J	16 x 7.0 J	17 x 8.0 J
Wheel type		Steel	Steel	Steel	Alloy
Wheel size (spare)		16 x 7.0 J	16 x 7.0 J	16 x 7.0 J	17 x 7.5 J
Wheel type (spare)		Steel	Steel	Steel	Steel

Weights and capacities					
Axle capacity	front	1,350 kg			
	rear	1,850 kg			
Gross Combined Mass (GCM) <sup>3</sup>	man	6,000 kg	-	6,000 kg	6,000 kg
	auto	-	6,000 kg	6,000 kg	6,000 kg
Gross Vehicle Mass (GVM)	man	3,200 kg	-	3,200 kg	3,200 kg
	auto	-	3,200 kg	3,200 kg	3,200 kg
Kerb weight (total)	man	1,694 kg	-	1,962 kg	1,984 kg
	auto	-	1,789 kg	1,979 kg	2,001 kg
Kerb weight (rear axle)	man	737 kg	-	853 kg	863 kg
	auto	-	778 kg	861 kg	870 kg
Seating capacity		3	4	5	5
Towball download <sup>4</sup>	maximum	235 kg			
Towing capacity <sup>4</sup>	braked	3,500 kg			
	unbraked	750 kg			

Payload <sup>5</sup> (maximum)	man	1,506 kg	-	1,238 kg	1,216 kg
	auto	-	1,411 kg	1,221 kg	1,199 kg

**Important:** The maximum payload<sup>5</sup> figure includes all occupants, fluids, options, accessories, modifications as well as cargo. Please refer to pages 32/33 for the payload capacity calculator to determine the permissible payload of cargo based on your specific needs.

- = Not available.

## 4x4

Powertrain		3.2L Single Cab Chassis GLX	3.2L Freestyle Cab Chassis GLX	3.2L Freestyle Cab Chassis GSX	3.2L Double Cab Wellside GLX	3.2L Double Cab Wellside GSX	3.2L Double Cab Wellside Limited
Engine type		3.2 litre in-line 5 cylinder 20 valve DOHC intercooled turbo diesel					
Engine capacity		3,198 cc					
Bore and stroke		89.0 mm x 100.7 mm					
Compression ratio		15.5 : 1					
Maximum power		147kW @ 3,000rpm					
Maximum torque		470Nm @ 1,750-2,500rpm					
Throttle control		Electronic (drive-by-wire)					
Fuel system		Common-rail, electronic direct injection					
Fuel tank capacity		80 litres					
Recommended fuel		Diesel					
Fuel consumption (l/100km) <sup>2</sup>	man (combined)	9.7	-	-	9.7	9.7	9.7
	auto (combined)	-	10	10	10	10	10
Emissions standard		Euro stage V					
Alternator		12 volts - 110 amps					
Manual transmission		6-speed	-	-	6-speed	6-speed	-
Automatic transmission		-	6-speed	6-speed	6-speed	6-speed	6-speed
Gear ratio - man/auto	1st	5.441 / -	- / 4.171	- / 4.171	5.441 / 4.171	5.441 / 4.171	- / 4.171
	2nd	2.839 / -	- / 2.342	- / 2.342	2.839 / 2.342	2.839 / 2.342	- / 2.342
	3rd	1.721 / -	- / 1.521	- / 1.521	1.721 / 1.521	1.721 / 1.521	- / 1.521
	4th	1.223 / -	- / 1.143	- / 1.143	1.223 / 1.143	1.223 / 1.143	- / 1.143
	5th	1.000 / -	- / 0.867	- / 0.867	1.000 / 0.867	1.000 / 0.867	- / 0.867
	6th	0.794 / -	- / 0.691	- / 0.691	0.794 / 0.691	0.794 / 0.691	- / 0.691
	reverse	4.935 / -	- / 3.403	- / 3.403	4.935 / 3.403	4.935 / 3.403	- / 3.403
	final drive	3.550 / -	- / 3.730	- / 3.730	3.550 / 3.730	3.550 / 3.730	- / 3.730
Transfer gear	high	1.000					
	low	2.717					

Chassis							
Brake diameter	front	302 mm					
	rear	295 mm					
Brake type	front	Ventilated disc					
	rear	Drum					
Steering type		Rack and pinion hydraulic power assist steering					
Suspension type	front	Independent double wishbone with coil over dampers and anti-roll bar					
	rear	Rigid (live) rear axle with leaf springs					
Turning circle	kerb to kerb	12.4 m					
Tyre size		255/70 R16	255/70 R16	265/65 R17	255/70 R16	265/65 R17	265/65 R17
Tyre index		111T	111T	112T	111T	112T	112T
Wheel size		16 x 7.0 J	16 x 7.0 J	17 x 8.0 J	16 x 7.0 J	17 x 8.0 J	17 x 8.0 J
Wheel type		Steel	Steel	Alloy	Steel	Alloy	Alloy
Wheel size (spare)		16 x 7.0 J	16 x 7.0 J	17 x 7.5 J	16 x 7.0 J	17 x 7.5 J	17 x 7.5 J
Wheel type (spare)		Steel	Steel	Steel	Steel	Steel	Steel

Weights and capacities							
Axle capacity	front	1,350 kg					
	rear	1,850 kg					
Gross Combined Mass (GCM) <sup>3</sup>	man	6,000 kg	-	-	6,000 kg	6,000 kg	-
	auto	-	6,000 kg	6,000 kg	6,000 kg	6,000 kg	6,000 kg
Gross Vehicle Mass (GVM)	man	3,200 kg	-	-	3,200 kg	3,200 kg	-
	auto	-	3,200 kg	3,200 kg	3,200 kg	3,200 kg	3,200 kg
Kerb weight (total)	man	1,791 kg	-	-	2,065 kg	2,087 kg	-
	auto	-	1,876 kg	1,907 kg	2,076 kg	2,098 kg	2,118 kg
Kerb weight (rear axle)	man	779 kg	-	-	898 kg	908 kg	-
	auto	-	816 kg	830 kg	903 kg	913 kg	921 kg
Seating capacity		3	4	4	5	5	5
Towball download <sup>4</sup>	maximum	235 kg					
Towing capacity <sup>4</sup>	braked	3,500 kg					
	unbraked	750 kg					

Payload <sup>5</sup> (maximum)	man	1,409 kg	-	-	1,135 kg	1,113 kg	-
	auto	-	1,324 kg	1,293 kg	1,125 kg	1,125 kg	1,082 kg

**Important:** The maximum payload<sup>5</sup> figure includes all occupants, fluids, options, accessories, modifications as well as cargo. Please refer to pages 32/33 for the payload capacity calculator to determine the permissible payload of cargo based on your specific needs.

- = Not available.

# SPECIFICATIONS

## 4x2

### Dimensions

		(A) 3.2L Single Cab Chassis GLX	(B) 3.2L Freestyle Cab Chassis GLX	(C) 3.2L Double Cab Wellside GLX	(D) 3.2L Double Cab Wellside GSX
Cargo box floor height to ground		-	-	835 mm	841 mm
Cargo box floor length		-	-	1,549 mm	1,549 mm
Cargo box floor width		-	-	1,560 mm	1,560 mm
Cargo box height		-	-	513 mm	513 mm
Cargo box tailgate opening width		-	-	1,330 mm	1,330 mm
Cargo box top length		-	-	1,485 mm	1,485 mm
Cargo box top width		-	-	1,500 mm	1,500 mm
Cargo box width between wheel arches		-	-	1,139 mm	1,139 mm
Ground clearance	laden	200 mm	200 mm	200 mm	205 mm
	unladen	232 mm	232 mm	232 mm	237 mm
Overall length		5,124 mm	5,124 mm	5,365 mm	5,365 mm
Overall width		1,850 mm	1,850 mm	1,850 mm	1,850 mm
Overall height		1,800 mm	1,804 mm	1,837 mm	1,821 mm
Overhang	front	919 mm	919 mm	919 mm	919 mm
	rear	985 mm	985 mm	1,234 mm	1,226 mm
Track	front	1,560 mm	1,560 mm	1,560 mm	1,560 mm
	rear	1,560 mm	1,560 mm	1,560 mm	1,560 mm
Wading depth		800 mm	800 mm	800 mm	800 mm
Wheelbase		3,220 mm	3,220 mm	3,220 mm	3,220 mm
Approach angle		27.6°	27.6°	27.6°	28.2°
Departure angle		28.4°	28.4°	27.1°	26.4°
Ramp breakover angle		24.4°	24.4°	24.4°	25.0°

- = Not available.

### Chassis

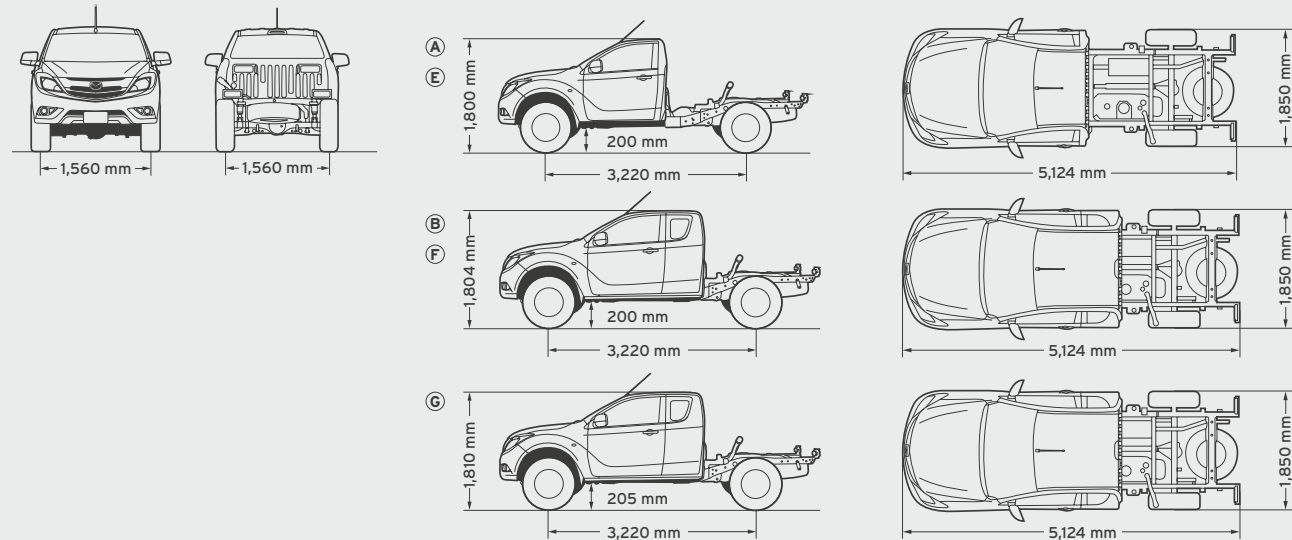

## 4x4

### Dimensions

		(E) 3.2L Single Cab Chassis GLX	(F) 3.2L Freestyle Cab Chassis GLX	(G) 3.2L Freestyle Cab Chassis GSX	(H) 3.2L Double Cab Wellside GLX	(I) 3.2L Double Cab Wellside GSX	(J) 3.2L Double Cab Wellside Limited
Cargo box floor height to ground		-	-	-	835 mm	841 mm	841 mm
Cargo box floor length		-	-	-	1,549 mm	1,549 mm	1,549 mm
Cargo box floor width		-	-	-	1,560 mm	1,560 mm	1,560 mm
Cargo box height		-	-	-	513 mm	513 mm	513 mm
Cargo box tailgate opening width		-	-	-	1,330 mm	1,330 mm	1,330 mm
Cargo box top length		-	-	-	1,485 mm	1,485 mm	1,485 mm
Cargo box top width		-	-	-	1,500 mm	1,500 mm	1,500 mm
Cargo box width between wheel arches		-	-	-	1,139 mm	1,139 mm	1,139 mm
Ground clearance	laden	200 mm	200 mm	205 mm	200 mm	205 mm	205 mm
	unladen	232 mm	232 mm	237 mm	232 mm	237 mm	237 mm
Overall length		5,124 mm	5,124 mm	5,124 mm	5,365 mm	5,365 mm	5,365 mm
Overall width		1,850 mm	1,850 mm	1,850 mm	1,850 mm	1,850 mm	1,850 mm
Overall height		1,800 mm	1,804 mm	1,810 mm	1,837 mm	1,821 mm	1,821 mm
Overhang	front	919 mm	919 mm	919 mm	919 mm	919 mm	919 mm
	rear	985 mm	985 mm	985 mm	1,234 mm	1,226 mm	1,226 mm
Track	front	1,560 mm	1,560 mm	1,560 mm	1,560 mm	1,560 mm	1,560 mm
	rear	1,560 mm	1,560 mm	1,560 mm	1,560 mm	1,560 mm	1,560 mm
Wading depth		800 mm	800 mm	800 mm	800 mm	800 mm	800 mm
Wheelbase		3,220 mm	3,220 mm	3,220 mm	3,220 mm	3,220 mm	3,220 mm
Approach angle		27.6°	27.6°	28.2°	27.6°	28.2°	28.2°
Departure angle		28.4°	28.4°	28.9°	27.1°	26.4°	26.4°
Ramp breakover angle		24.4°	24.4°	25.0°	24.4°	25.0°	25.0°

- = Not available.

### Wellside

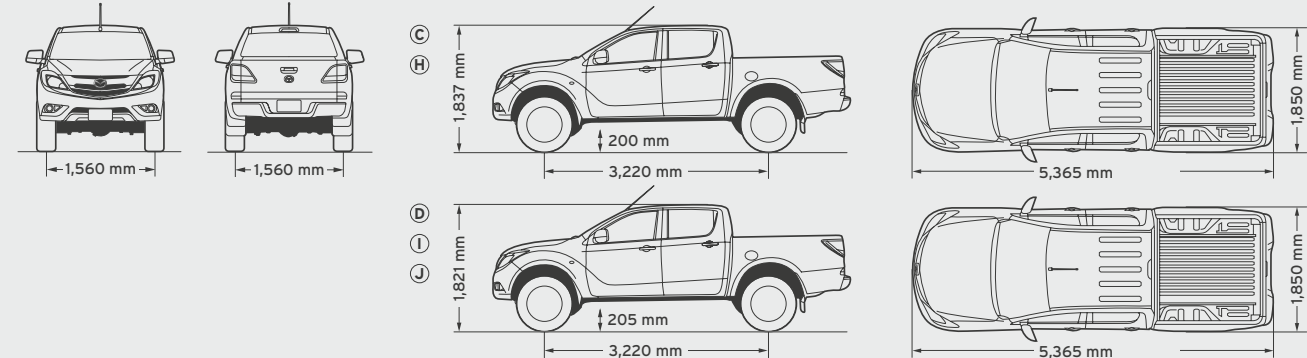

# SPECIFICATIONS

## 4x2

### Exterior

		3.2L Single Cab Chassis GLX	3.2L Freestyle Cab Chassis GLX	3.2L Double Cab Wellside GLX	3.2L Double Cab Wellside GSX
Cargo box features	lockable centre tailgate release (black)	-	-	●	-
	lockable centre tailgate release (chrome)	-	-	-	●
	double wall construction	-	-	●	●
	interior rope hooks (6)	-	-	●	●
Door handles (black)	●	●	●	-	
Door handles (chrome)	-	-	-	●	
Fog-lamps (front)	-	-	-	●	
Freestyle door system	-	●	-	-	
Front bumper (body coloured)	●	●	●	●	
Fuel filler cap (lockable)	●	●	-	-	
Glass: green-tinted (all windows)	●	●	●	●	
Headlamps (Halogen)	●	●	●	●	
Ladder rack	-	-	●	-	
Mudflaps (front)	●	●	●	●	
Mudflaps (rear)	-	-	●	●	
Power mirrors (black)	●	●	●	-	
Power mirrors (chrome)	-	-	-	●	
Power windows	●	●	●	●	
Rear step bumper (chrome)	-	-	●	●	
Side steps (tubular, aluminium finish)	-	-	-	●	
Tailgate (lockable)	-	-	●	●	

### Interior

Air-conditioning		●	●	●	-
Air-conditioning (dual-zone climate control)		-	-	-	●
Ambient temperature gauge		-	-	-	●
Auxiliary 12-volt power outlets		●	●	●	●
Centre armrest console with dual compartments		-	●	●	●
Critical function warning lights/chimes		●	●	●	●
Cruise control		●	●	●	●
Cupholders		●	●	●	●
Door pockets		●	●	●	●
Driver's left footrest		●	●	●	●
Floor covering	carpet	-	-	-	●
	vinyl	●	●	●	-
Glove box (lockable and illuminated)		●	●	●	●
Headlamps auto on/off function		-	-	-	●
Illuminated entry system with delayed fade		●	●	●	●
Instrument panel light dimmer		●	●	●	●
Interior illumination	dome lamp	-	●	●	●
	map reading spot lamps	●	●	●	●
	power window switch (driver)	●	●	●	●
Leather-wrapped	gear shift knob	-	-	-	○
	steering wheel	-	-	-	●
Low fuel warning light		●	●	●	●
Overhead sunglass storage box		●	●	●	●
Passenger assist grips		●	●	●	●
Rear-view mirror with auto dimming function		-	-	-	●
Seat trim	cloth	●	●	●	-
	sports cloth	-	-	-	●
Seat (driver's bucket) with	adjustable head restraint	●	●	●	●
	height and lumbar adjustment	-	●	●	●
	rake and slide adjustment	●	●	●	●
Seat (passengers' front bench) with	adjustable head restraint	●	-	-	-
Seat (passengers' front bucket) with	adjustable head restraint	-	●	●	●
	rake and slide adjustment	-	●	●	●
	seat back pocket	-	●	●	●

● = Standard Feature, ○ = Available on manual model, - = Not available

## 4x4

### Exterior

		3.2L Single Cab Chassis GLX	3.2L Freestyle Cab Chassis GLX	3.2L Freestyle Cab Chassis GSX	3.2L Double Cab Wellside GLX	3.2L Double Cab Wellside GSX	3.2L Double Cab Wellside Limited
Cargo box features	lockable centre tailgate release (black)	-	-	-	●	-	-
	lockable centre tailgate release (chrome)	-	-	-	-	●	●
	double wall construction	-	-	-	●	●	●
	interior rope hooks (6)	-	-	-	●	●	●
Door handles (black)	●	●	-	●	-	-	
Door handles (chrome)	-	-	●	-	●	●	
Fog-lamps (front)	-	-	●	-	●	●	
Freestyle door system	-	●	●	-	-	-	
Front bumper (body coloured)	●	●	●	●	●	●	
Fuel filler cap (lockable)	●	●	●	-	-	-	
Glass: green-tinted (all windows)	●	●	●	●	●	-	
Glass: privacy-tinted (rear side and back windows)	-	-	-	-	-	●	
Headlamps (Halogen)	●	●	●	●	●	●	
Ladder rack	-	-	-	●	-	-	
Mudflaps (front)	●	●	●	●	●	●	
Mudflaps (rear)	-	-	-	●	●	●	
Power mirrors (black)	●	●	-	●	-	-	
Power mirrors (chrome)	-	-	●	-	●	●	
Power mirrors (folding function, heated) with twin indicator	-	-	-	-	-	●	
Power windows	●	●	●	●	●	●	
Rear step bumper (chrome)	-	-	-	●	●	●	
Side steps (tubular, aluminium finish)	-	-	●	-	●	●	
Tailgate (lockable)	-	-	-	●	●	●	
Under-body impact protection	●	●	●	●	●	●	

### Interior

Air-conditioning		●	●	-	●	-	-
Air-conditioning (dual-zone climate control)		-	-	●	-	●	●
Ambient temperature gauge		-	-	-	-	●	●
Auxiliary 12-volt power outlets		●	●	●	●	●	●
Centre armrest console with dual compartments		-	●	●	●	●	●
Critical function warning lights/chimes		●	●	●	●	●	●
Cruise control		●	●	●	●	●	●
Cupholders		●	●	●	●	●	●
Door pockets		●	●	●	●	●	●
Driver's left footrest		●	●	●	●	●	●
Floor covering	carpet	-	-	●	-	●	●
	vinyl	●	●	-	●	-	-
Glove box (lockable and illuminated)		●	●	●	●	●	●
Headlamps auto on/off function		-	-	●	-	●	●
Illuminated entry system with delayed fade		●	●	●	●	●	●
Instrument panel light dimmer		●	●	●	●	●	●
Interior illumination	dome lamp	-	●	●	●	●	●
	map reading spot lamps	●	●	●	●	●	●
	power window switch (driver)	●	●	●	●	●	●
Leather-wrapped	gear shift knob	-	-	-	-	○	-
	steering wheel	-	-	-	-	●	●
Low fuel warning light		●	●	●	●	●	●
Overhead sunglass storage box		●	●	●	●	●	●
Passenger assist grips		●	●	●	●	●	●
Rear-view mirror with auto dimming function		-	-	●	-	●	●
Seat trim	cloth	●	●	-	●	-	-
	sports cloth	-	-	●	-	●	-
	leather <sup>9</sup>	-	-	-	-	-	●
Seat (driver's bucket) with	8-way power adjustment	-	-	-	-	-	●
	adjustable head restraint	●	●	●	●	●	●
	height and lumbar adjustment	-	●	●	●	●	●
Seat (passengers' front bench) with	rake and slide adjustment	●	●	●	●	●	●
	adjustable head restraint	●	-	-	-	-	-
	adjustable head restraint	-	●	●	●	●	●
Seat (passengers' front bucket) with	rake and slide adjustment	-	●	●	●	●	●
	seat back pocket	-	●	●	●	●	●

● = Standard Feature, ○ = Available on manual model, - = Not available

# SPECIFICATIONS

## 4x2

		3.2L Single Cab Chassis GLX	3.2L Freestyle Cab Chassis GLX	3.2L Double Cab Wellside GLX	3.2L Double Cab Wellside GSX
<b>Interior (continued)</b>					
Seat (passengers' rear bench) with	adjustable head restraints	-	-	●	●
	foldable seat base and under-seat storage	-	-	●	●
	centre armrest	-	-	-	●
Seat (passengers' rear jump) with	removable seat base and under-seat storage	-	●	-	-
Tachometer and electronic odometer/tripmeter		●	●	●	●
Tilt-adjustable steering wheel		●	●	●	●
Trip computer <sup>7</sup> (current and average fuel consumption, distance to empty and average vehicle speed)		●	●	●	●
Vanity mirror (front passenger)		●	●	●	●
Window demister (rear)		●	●	●	●
Wipers (front) 2-speed with rain-sensing function		-	-	-	●
Wipers (front) 2-speed with variable intermittent function		●	●	●	-
<b>Infotainment</b>					
7.8-inch full colour touchscreen display		-	-	-	●
3.5-inch multi-information display		●	●	●	-
AM/FM tuner		●	●	●	●
Auxiliary input (3.5mm MP3 player compatible)		●	●	●	●
Bluetooth® hands-free phone and audio capability <sup>1</sup>		●	●	●	●
CD player, single disc (MP3/WMA compatible)		●	●	●	●
Satellite navigation (with 3 years free map updates)		-	-	-	●
Speakers (4)		●	-	-	-
Speakers (6)		-	●	●	●
Steering wheel-mounted audio controls		●	●	●	●
USB input (iPod® compatible)		●	●	●	●
<b>Safety and Security</b>					
Airbags SRS	front (driver and passenger)	●	●	●	●
	side (front)	-	●	●	●
	curtain (front)	●	-	-	-
	curtain (front and rear)	-	●	●	●
Anti-lock Braking System (ABS)		●	●	●	●
Child restraint anchor points (2)		-	●	●	●
Childproof rear door locks		-	-	●	●
Dynamic Stability Control (DSC) - switchable on/off		●	●	●	●
Electronic Brake-force Distribution (EBD)		●	●	●	●
Emergency Brake Assist (EBA)		●	●	●	●
Engine immobiliser		●	●	●	●
Emergency Stop Signal (ESS)		●	●	●	●
High mount stop lamp		-	-	●	●
Hill Launch Assist (HLA)		●	●	●	●
Intrusion-minimising brake pedal		●	●	●	●
Left-hand-side convex (wide angle) exterior mirror		●	●	●	●
Load Adaptive Control (LAC)		●	●	●	●
Locking Rear Differential (LRD) - switchable on/off		●	●	●	●
One touch (up and down) power window (driver)		●	●	●	●
Parking sensors (rear)		-	-	●	●
Remote central locking (2 transmitters with retractable key)		●	●	●	●
Reversing camera		-	-	-	●
Roll Stability Control (RSC)		●	●	●	●
Seat-belt warning audible and visual (driver)		●	●	●	●
Seat-belt warning audible and visual (front passenger)		-	●	●	●
Seat-belts 3-point lap-sash (all seats)		●	●	●	●
Seat-belts (front) with	height adjustable shoulder anchorages	-	-	●	●
	pretensioners and load limiters	●	●	●	●
Side impact door beams		●	●	●	●
Traction Control System (TCS)		●	●	●	●
Trailer Sway Control (TSC)		●	●	●	●

● = Standard Feature, - = Not available

## 4x4

		3.2L Single Cab Chassis GLX	3.2L Freestyle Cab Chassis GLX	3.2L Freestyle Cab Chassis GSX	3.2L Double Cab Wellside GLX	3.2L Double Cab Wellside GSX	3.2L Double Cab Wellside Limited
<b>Interior (continued)</b>							
Seat (passengers' rear bench) with	adjustable head restraints	-	-	-	●	●	●
	foldable seat base and under-seat storage	-	-	-	●	●	●
	centre armrest	-	-	-	-	●	●
Seat (passengers' rear jump) with	removable seat base and under-seat storage	-	●	●	-	-	-
Tachometer and electronic odometer/tripmeter		●	●	●	●	●	●
Tilt-adjustable steering wheel		●	●	●	●	●	●
Trip computer <sup>7</sup> (current and average fuel consumption, distance to empty and average vehicle speed)		●	●	●	●	●	●
Vanity mirror (front passenger)		●	●	●	●	●	●
Window demister (rear)		●	●	●	●	●	●
Wipers (front) 2-speed with rain-sensing function		-	-	●	-	●	●
Wipers (front) 2-speed with variable intermittent function		●	●	-	●	-	-
<b>Infotainment</b>							
7.8-inch full colour touchscreen display		-	-	●	-	●	●
3.5-inch multi-information display		●	●	-	●	-	-
AM/FM tuner		●	●	●	●	●	●
Auxiliary input (3.5mm MP3 player compatible)		●	●	●	●	●	●
Bluetooth® hands-free phone and audio capability <sup>1</sup>		●	●	●	●	●	●
CD player, single disc (MP3/WMA compatible)		●	●	●	●	●	●
Satellite navigation (with 3 years free map updates)		-	-	●	-	●	●
Speakers (4)		●	-	-	-	-	-
Speakers (6)		-	●	●	●	●	●
Steering wheel-mounted audio controls		●	●	●	●	●	●
USB input (iPod® compatible)		●	●	●	●	●	●
<b>Safety and Security</b>							
Airbags SRS	front (driver and passenger)	●	●	●	●	●	●
	side (front)	-	●	●	●	●	●
	curtain (front)	●	-	-	-	-	-
	curtain (front and rear)	-	●	●	●	●	●
Anti-lock Braking System (ABS)		●	●	●	●	●	●
Child restraint anchor points (2)		-	●	●	●	●	●
Childproof rear door locks		-	-	-	●	●	●
Dynamic Stability Control (DSC) - switchable on/off		●	●	●	●	●	●
Electronic Brake-force Distribution (EBD)		●	●	●	●	●	●
Emergency Brake Assist (EBA)		●	●	●	●	●	●
Engine immobiliser		●	●	●	●	●	●
Emergency Stop Signal (ESS)		●	●	●	●	●	●
High mount stop lamp		-	-	-	●	●	●
Hill Descent Control (HDC)		●	●	●	●	●	●
Hill Launch Assist (HLA)		●	●	●	●	●	●
Intrusion-minimising brake pedal		●	●	●	●	●	●
Left-hand-side convex (wide angle) exterior mirror		●	●	●	●	●	●
Load Adaptive Control (LAC)		●	●	●	●	●	●
Locking Rear Differential (LRD) - switchable on/off		●	●	●	●	●	●
One touch (up and down) power window (driver)		●	●	●	●	●	●
Parking sensors (rear)		-	-	-	●	●	●
Remote central locking (2 transmitters with retractable key)		●	●	●	●	●	●
Reversing camera		-	-	●	-	●	●
Roll Stability Control (RSC)		●	●	●	●	●	●
Seat-belt warning audible and visual (driver)		●	●	●	●	●	●
Seat-belt warning audible and visual (front passenger)		-	●	●	●	●	●
Seat-belts 3-point lap-sash (all seats)		●	●	●	●	●	●
Seat-belts (front) with	height adjustable shoulder anchorages	-	-	-	●	●	●
	pretensioners and load limiters	●	●	●	●	●	●
Side impact door beams		●	●	●	●	●	●
Traction Control System (TCS)		●	●	●	●	●	●
Trailer Sway Control (TSC)		●	●	●	●	●	●

● = Standard Feature, - = Not available

# PAYLOAD AND TOWING CALCULATOR



## STATEMENT OF PURPOSE

The Payload and Towing Calculator<sup>5</sup> has been provided to promote safe operation of your Mazda BT-50. Its objective is to ensure the aspects of **load capacity** and **weight distribution** fall within safe limits. Please use this calculator as a general guide only.

Note: To reduce complexity with this tool, we have not included calculations for Front Axle Loading. For general use situations, Front Axle Capacity is not likely to be exceeded. However, for specific requirements or unique applications, please consult your Mazda Dealer.

## GLOSSARY

### GROSS COMBINED MASS (GCM):

The maximum total combined weight of a vehicle including its cargo, occupants, accessories and any towed mass.

### TRAILER MASS:

The total weight of a trailer and its load, including the towbar download.

### GROSS VEHICLE MASS (GVM):

The maximum weight of a vehicle, including all accessories, body construction, occupants and cargo.

### KERB WEIGHT:

The unladen weight of the vehicle, (less occupants, tray/body and accessories), including fuel.

### TOWBALL DOWNLOAD:

The downward load that is applied to the tow coupling when a trailer is attached (this load is part of the Trailer Mass).

### VEHICLE ACCESSORIES:

Any attachment/device that has been added to the vehicle after it was manufactured (e.g. tray, sports bar, canopy etc.).

### REAR AXLE CAPACITY:

The maximum total weight the rear axle can carry, including the unladen weight of the axle.

### PROVISIONAL PAYLOAD:

This is the INTERIM calculated payload weight, without taking load distribution into account.

### PERMISSIBLE PAYLOAD:

This is the FINAL payload figure, with weight distribution (i.e. rear axle capacity) accounted for.

## INSTRUCTIONS

- To calculate PERMISSIBLE payload for your needs in column (B), use example in column (A) as a guide.
- Please work through sections A-H in sequence.
- Model-specific weights and capacities data for elements f) and p) can be found on pages 24 and 25.
- PROVISIONAL Payload is calculated by deducting fixed and variable weights from the Gross Combined Mass (GCM) or Gross Vehicle Mass (GVM) figures (where appropriate).
- PERMISSIBLE (final) Payload is then confirmed once weight distribution is calculated, by checking the PROVISIONAL Payload against the maximum Rear Axle Capacity.
- For specific requirements, please consult your Mazda Dealer.

		(A) Example Worksheet	(B) Your Worksheet
<b>BT-50 MODEL:</b>		4x2 Single Cab Chassis GLX 6MT	
<b>SECTION A</b>			
Gross Combined Mass (GCM)		<b>a) 6,000kg</b>	<b>a) 6,000kg</b>
<b>SECTION B TRAILER</b>			
MINUS:	Trailer Mass (If towing; otherwise enter "0")	b) 2,000kg	b) kg
EQUALS:	Residual Mass	c) 4,000kg	c) kg
		<b>[c] = [a] - [b]</b>	
<b>SECTION C GVM</b>			
Gross Vehicle Mass (GVM)		<b>d) 3,200kg</b>	<b>d) 3,200kg</b>
LESSER VALUE OF:	Residual Mass [c] OR GVM [d]	e) 3,200kg	e) kg
		<b>[e] = lesser value of [c] or [d]</b>	
<b>SECTION D KERB WEIGHT</b>			
MINUS:	Kerb Weight	f) 1,694kg	f) kg
EQUALS:		g) 1,506kg	g) kg
		<b>[g] = [e] - [f]</b>	
<b>SECTION E TOWBALL DOWNLOAD</b>			
Maximum Towball Download		<b>h) 235kg</b>	<b>h) 235kg</b>
Actual Towball Download (If towing; otherwise enter "0")		i) 150kg	i) kg
LESSER VALUE OF:	Maximum Towball Download [h] OR Actual Towball Download [i]	j) 150kg	j) kg
		<b>[j] = lesser value of [h] or [i]</b>	
EQUALS:		k) 1,356kg	k) kg
		<b>[k] = [g] - [j]</b>	
<b>SECTION F ACCESSORIES / OCCUPANTS</b>			
MINUS:	Vehicle Accessories (e.g. Tray, Canopy, Sports Bar etc)	l) 300kg	l) kg
	Occupants/Luggage/Tools etc	m) 200kg	m) kg
EQUALS:	PROVISIONAL Payload	n) 856kg	n) kg
		<b>[n] = [k] - [l] - [m]</b>	
<b>SECTION G REAR AXLE PAYLOAD</b>			
Maximum Rear Axle Capacity		<b>o) 1,850kg</b>	<b>o) 1,850kg</b>
MINUS:	Kerb Weight (Rear Axle)	p) 737kg	p) kg
EQUALS:		q) 1,113kg	q) kg
		<b>[q] = [o] - [p]</b>	
MINUS:	Towball Download [j]	j) 150kg	j) kg
	Vehicle Accessories [l]	l) 300kg	l) kg
EQUALS:	Maximum Rear Axle Payload	r) 663kg	r) kg
		<b>[r] = [q] - [j] - [l]</b>	
<b>SECTION H FINAL PAYLOAD CONFIRMATION</b>			
LESSER VALUE OF:	Maximum Rear Axle Payload [r] OR	r) 663kg	r) kg
	PROVISIONAL Payload [n]	n) 856kg	n) kg
EQUALS:	<b>PERMISSIBLE PAYLOAD</b>	<b>s) 663kg</b>	<b>s) kg</b>
		<b>[s] = lesser value of [n] or [r]</b>	

## ENJOY MAZDA BT-50 WITH CONFIDENCE



### mazda commercialcare

Every new Mazda BT-50 comes with mazda commercialcare included. This comprehensive cover includes 3 years of Mazda On Call Roadside Assistance plus 3 years or 150,000km (whichever occurs first) of a comprehensive Mazda Warranty at no extra cost. It also entitles you to 3 years or 100,000km (whichever occurs first) of Fixed Price Servicing<sup>9</sup>

### Maintain that Zoom-Zoom for no more than \$200 per service<sup>8</sup>

Regular servicing is essential because it keeps your Mazda in peak condition for longer, saving you money in fuel and parts, keeping your vehicle safer on the road. That's why we offer 3 years or 100,000km (whichever occurs first) of Fixed Price Servicing as part of mazda commercialcare. This means you pay no more than \$200 (incl. GST) per service at scheduled service intervals every 6 months or 10,000km (whichever comes

first)<sup>9</sup> Of course, each service will be carried out by Mazda factory-trained Service Specialists using the latest in vehicle diagnostic equipment, in order to keep your BT-50 operating at optimum driving performance.

### Help is at hand - Mazda Roadside Assistance

If something goes wrong when you're travelling then we're here to help. Mazda On Call is a roadside assistance programme available to Mazda owners 24-hours a day, 365 days a year - included as part of your mazda commercialcare cover. So, if you run out of fuel, lock your keys in the car or simply forget how to programme the stereo, all you need to do is call us. Our support centres are ready to help out with any mechanical, medical and even legal advice you might need.

### Accessories add enjoyment

Mazda BT-50 combines amazing versatility with refined design. And with Mazda Genuine Accessories, owning one becomes even more satisfying. They let you personalise your vehicle and protect your investment. They also deliver superb design, quality, fit and safety. Mazda Genuine Accessories let you add even more Zoom-Zoom. Find out more about mazda commercialcare and genuine BT-50 accessories at [mazda.co.nz](http://mazda.co.nz)

*mazda*  
**COMMERCIALCARE**

(1) Please check the compatibility of your Bluetooth® device (particularly your mobile phone) with the specific Mazda vehicle you intend to purchase as not all devices operate correctly. Consult your Mazda Dealer for further information. (2) Fuel consumption figures are based on ADR81/02. They are useful in comparing the fuel consumption of different vehicles. They may not be the fuel consumption achieved in practice. This will depend on traffic, road conditions and how the vehicle is driven. Combined fuel consumption figures quoted in this brochure relate to models built on or after 1 July 2016. (3) GCM is the total permissible combined weight of the vehicle and trailer being towed including occupants, accessories, fuel and cargo. Please refer to the Towing and Payload Calculator on Pages 32/33 for guidance. (4) A Genuine Mazda towbar is recommended. Towing Capacity is governed by the Gross Combined Mass (GCM) of the vehicle not being exceeded. Please refer to the Towing and Payload Calculator on Pages 32/33 for guidance. (5) The weight of any vehicle occupants, options, accessories, modifications, cargo, axle capacity and towball download must be included when calculating payload weight. Please refer to the Towing and Payload Calculator on Pages 32/33 for guidance. (6) The Towing and Payload Calculator is a guide only; to promote safe practice in line with the safety systems and capabilities of the vehicle. Consult your Mazda Dealer for further information. (7) Trip computer displays current and average fuel consumption, distance to empty and average vehicle speed. (8) mazda commercialcare Fixed Price Servicing is only available for BT-50 'UP' and 'UR' series models built from August 2011 onward. (9) Leather trim includes Mazda deluxe leatherette on selected high impact surfaces.

All care is taken to ensure the accuracy of this brochure at the time of publication. Specifications, features and model availability may vary from Dealer to Dealer and may change without notice. Please refer to [mazda.co.nz](http://mazda.co.nz) or consult your Mazda Dealer prior to placing an order to ascertain current information on model availability, specifications, options, features and prices. Mazda Motors of New Zealand Limited will not be liable for any loss arising from the information in this brochure, whether in negligence or otherwise. Mazda Motors of New Zealand Limited, PO Box 132 057, Sylvia Park, Auckland 1644. Due to the nature of the printing process, colours may vary from those shown in this brochure. Ask your Dealer to show you a product sample. Published January 2018. MZ4900593

## MAZDA BT-50 COLOUR AND TRIM

### BODY COLOURS

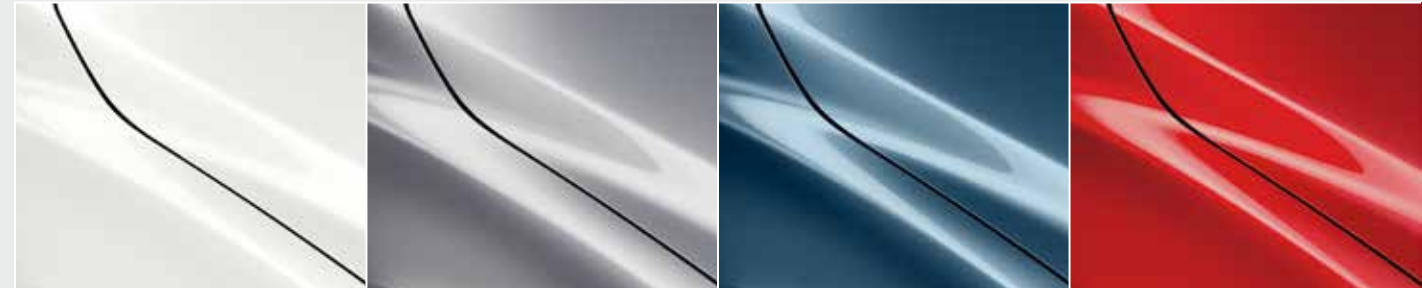

Cool White

Aluminium Metallic

Blue Reflex Mica

True Red



Titanium Flash Mica

Deep Crystal Blue Mica

Black Mica

### INTERIOR TRIMS



Black Cloth (GLX)

Black Sports Cloth (GSX)

Black Leather (Limited)



*zoom-zoom*



Mazda NZ

Like us on the official Mazda New Zealand fan page for the latest pictures, videos, events, news and competitions. Ask questions, give feedback or upload your own photos. Find us by searching "Mazda NZ" on Facebook now.



Mazda NZ

Visit Mazda New Zealand's YouTube channel. You'll find video content with exclusive behind-the-scenes footage. Find us by searching "Mazda NZ" on YouTube now.



Mazda\_nz

Find us by searching "Mazda\_nz" on Instagram now.

Published January 2018. MZ4900593

For further information visit [mazda.co.nz](http://mazda.co.nz)