



A4





**The new Audi A4.**

# Forward thinking.

The Audi A4 is Audi's best selling model and represents the Four Rings like no other model. With cutting edge technology, impressive drivability and a timeless design, the Audi A4 represents Audi's forward thinking attitude at the highest level.



# All-rounder.

With its new design language and an almost completely new body, the sporty character of the Audi A4 sedan is more evident than ever. The large MMI touch display offers the familiarity of a smartphone's operating interface and the many engine options now come with mild-hybrid systems (MHEV) – providing comfort and efficiency at the same time.

The Audi A4 is a perfectly-balanced car, with its success formula made up of functionality, design, comfort, luxury and innovation.



# Sporty and modern.

Thanks to the sportier design highlights, the Audi A4 looks even more dynamic and sophisticated – a broader and flatter Singleframe grille, with horizontal lines emphasizing the width at the front and rear. The offset diffuser surface with the integrated trapezoidal tailpipes ensures a sporty finish. The side view is further defined by the distinctive muscles above the fenders and the lower set shoulder line in between, forming strong contours above the wheels.



Another visual feature of the Audi A4 is its progressive lighting design and headlights with LED technology that provides daylight illumination.

When the turn signals are activated, the impressive rear dynamic indicators ensure unmistakable recognition value.





## Comfort and connectivity.

In the interior of the Audi A4, experience an arrangement of elements that is geared towards lightness and space. With its new MMI system, the highly connected Audi A4 offers a user experience similar to a contemporary smartphone.

The 10.1-inch high resolution MMI touch display offers acoustic feedback – replacing the previous rotary/pushbutton control and facilitating the ease of use. Additionally, the newly introduced natural-language voice control system understands the many phrases used in everyday speech without the need to define prescribed terms.



In the infotainment area, the full HD 12.3-inch Audi virtual cockpit plus clearly displays important functions directly in front of you. It also has two additional views that can be set in the MMI – in addition to the sport layout like in the S-line models, the RPM and speed indicators are shown as bar diagrams with angular red graphical elements. The Audi virtual cockpit plus offers a display graphic with dynamic design.

Audi virtual cockpit plus



Memory function settings for driver's seat



MMI navigation plus with MMI touch

# Audi intelligent technologies.

## Cruise control

Cruise control helps the driver maintain a desired driving speed, that can be set by a switch and overridden when you press the brake. The system offers relief to drivers – especially on long trips, while contributing towards lower fuel consumption.

## Hold assist

Hold assist automatically switches over to the electromechanical parking brake when the vehicle is stopped for a longer period of time, ensuring the vehicle will remain stationary even without activation of the parking brake. It enables convenient drive-offs when the car is on the usual inclines and descents of street traffic and prevents the vehicle from rolling.

## Parking aid plus with reversing camera

Parking aid plus informs the driver, visually and audibly, about obstacles in the front and back of the vehicle while providing the rear view when reversing. Ultrasonic sensors inconspicuously integrated into the bumpers measure the distance with the virtual driving path display showing lateral guide lines, assisting in convenient parking and exiting.

## Optional Audi pre sense basic

Audi pre sense basic initiates preventive safety measures for the driver and passengers once it recognizes a critical driving state. For instance, it intervenes if the Electronic Stabilisation Control (ESC) sensors detect skidding or hard braking. It then applies tension to the seat belts electrically, to reduce forward or lateral movements. The side windows will automatically close and hazard warning lights are activated to alert following traffic.

# Powerful look.

Select the paint colour that best suits your personality. Secure in the knowledge that the quality will be superb, because your vehicle is painted not just once, but four times. So not only do you look radiant in your Audi, your car is also protected from environmental influences and wear. Ensuring that the car maintains its powerful look throughout its entire lifetime.

Navarra blue, metallic

Terra grey, metallic

Tango red, metallic

Glacier white, metallic



Manhattan grey, metallic

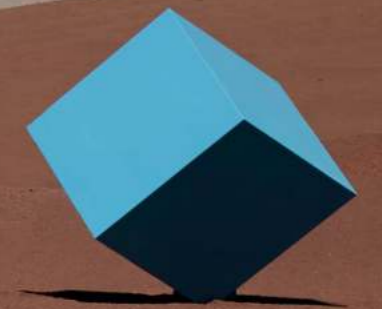

Nogaro blue, pearl effect (optional)



## Audi A4 Sedan

### Dimensions in mm

Dimensions are for unladen vehicle weight.  
Luggage compartment volume: 460l.  
Turning circle approx. 11.6 m.

\* Maximum headroom. <sup>1</sup> Shoulder room width. <sup>2</sup> Elbow room width.

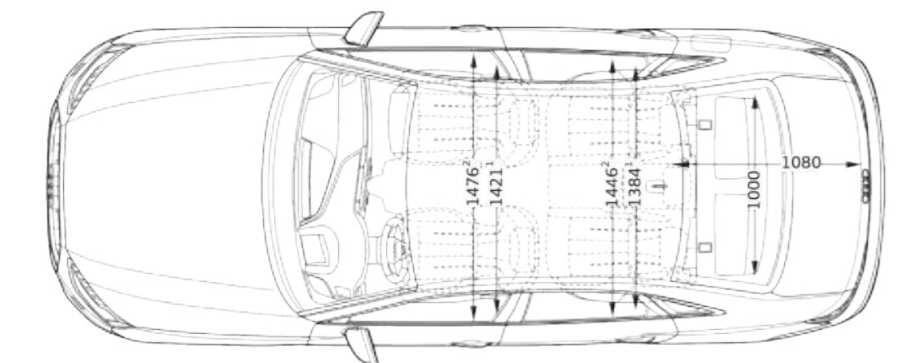
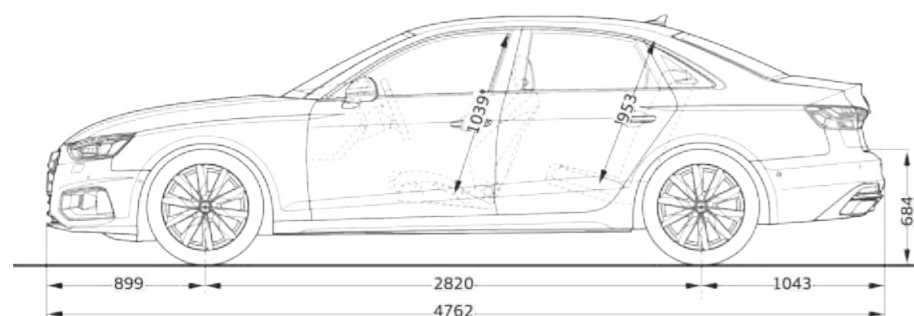
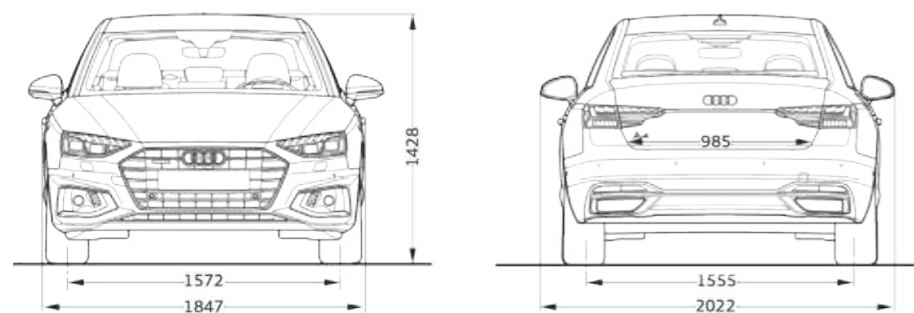

## Audi A4 Avant

### Dimensions in mm

Dimensions are for unladen vehicle weight.  
Luggage compartment volume: 495l.  
Turning circle approx. 11.6 m.

\* Maximum headroom. <sup>1</sup> Shoulder room width. <sup>2</sup> Elbow room width.

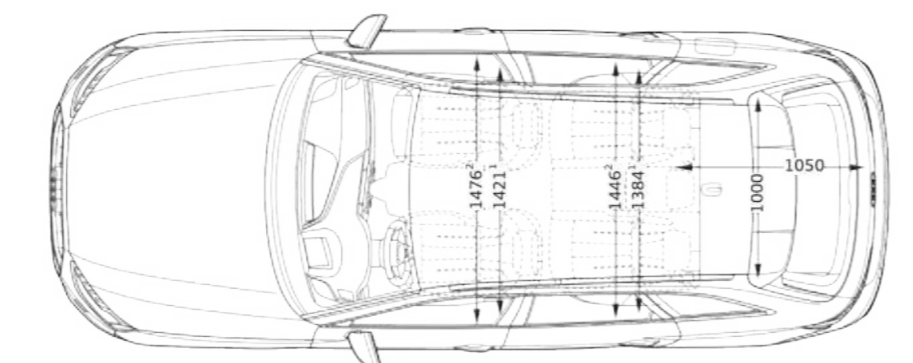
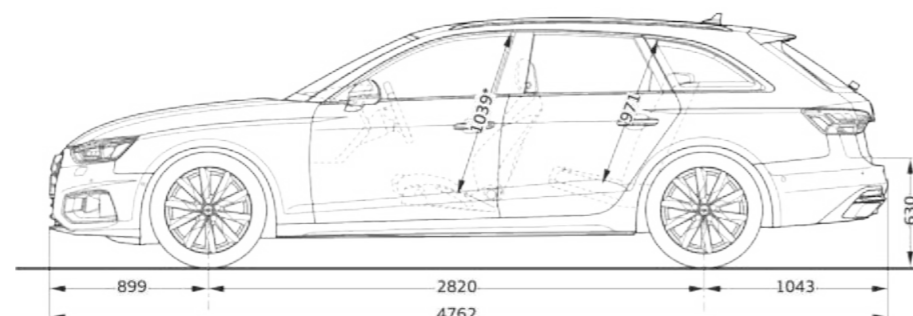
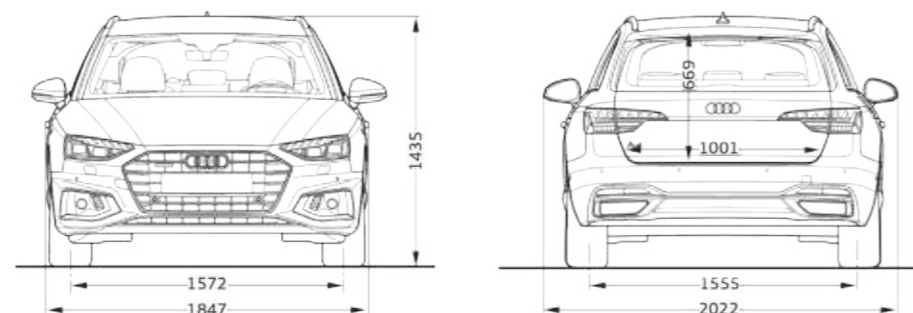

## Model

Engine type

Displacement in cc (valves per cylinder)

Max. output in kW(hp) at rpm

Max. torque in Nm at rpm

**Power transmission**

Drive type

Transmission type

**Weights/capacities**

Kerb weight in kg

Max laden weight in kg

Permissible roof load limit in kg

Fuel tank capacity in l

**Performance/consumption**

Top speed in km/h

Acceleration 0-100 km/h in s

Fuel grade

Fuel consumption (combined) in l/100 km

VES banding

Emission standard

**A4 Sedan 2.0 TFSI S tronic**

4-cylinder inline petrol engine with direct fuel injection, turbocharging and Audi valvelift system

1,984 (4)

110 (150) / 3,900 – 6,000

270 / 1,350 – 3,900

Front-wheel drive

7-speed S tronic transmission

1,440

2,035

90

54

225

8.9

Sulphur-free RON 95

6.1

B

EU6

**A4 Sedan advanced 2.0 TFSI S tronic**

4-cylinder inline petrol engine with direct fuel injection, turbocharging and Audi valvelift system

1,984 (4)

140 (190) / 4,200 – 6,000

320 / 1,450 – 4,200

Front-wheel drive

7-speed S tronic transmission

1,455

2,040

90

54

240

7.3

Sulphur-free RON 95

6.3

B

EU6

**A4 Sedan advanced 2.0 TFSI quattro S tronic**

4-cylinder inline petrol engine with direct fuel injection, turbocharging and Audi valvelift system

1,984 (4)

183 (249) / 5,000 – 6,500

370 / 1,600 – 4,300

quattro with ultra technology

7-speed S tronic transmission

1,545

2,110

90

58

250

5.8

Sulphur-free RON 95

\*TBA

\*TBA

EU6

\*TBA - The Audi A4 Sedan advanced 2.0 TFSI quattro is yet to be homologated.

<b>Model</b>	<b>A4 Avant 2.0 TFSI S tronic</b>
Engine type	4-cylinder inline petrol engine with direct fuel injection, turbocharging and Audi valvelift system
Displacement in cc (valves per cylinder)	1,984 (4)
Max. output in kW(hp) at rpm	110 (150) / 3,900 – 6,000
Max. torque in Nm at rpm	270 / 1,350 – 3,900
<b>Power transmission</b>	
Drive type	Front-wheel drive
Transmission type	7-speed S tronic transmission
<b>Weights/capacities</b>	
Kerb weight in kg	1,500
Max laden weight in kg	2,100
Permissible roof load limit in kg	90
Fuel tank capacity in l	54
<b>Performance/consumption</b>	
Top speed in km/h	220
Acceleration 0–100 km/h in s	9.2
Fuel grade	Sulphur-free RON 95
Fuel consumption (combined) in l/100 km	6.4
VES banding	B
Emission standard	EU6



## Premium Automobiles

281 Alexandra Road Singapore 159938 Tel: 6836 2223

55 Ubi Road 1 Singapore 408699 Tel: 6366 2323

Information is accurate as at June 2020.

The models, colours and equipment options illustrated and described in this brochure and some of the services listed are not available in Singapore. Some of the cars illustrated are equipped with optional features that are chargeable. Details concerning the delivery specifications, appearance, performance, dimensions and weights, fuel consumption and running costs of the vehicle were correct to the best of our knowledge at the time of going to press. Deviations from the colours and shapes shown in the illustrations may occur. No liability is accepted for errors and printing errors.