



The Power to Surprise

stinger



CLASSIC SPIRIT TUNED FOR MODERN TIMES

Kia's first-ever rear-wheel-drive sports sedan, the Stinger, is a five-door fastback that echoes the style and substance of gran turismo legends with its long hood, muscular haunches and stylish spoked wheels, along with serious game-changing performance figures. The Stinger offers an extended wheelbase for maximum cabin space, optional all-wheel-drive, and driver assistance and entertainment technologies unimaginable during the glory days of muscle cars.



PERFORMANCE-BASED SENSATIONS

Performance sedans have an illustrious rear-wheel drive history. Apply the latest technologies and materials to this tradition, and the result is a remarkably responsive, dynamic and rewarding driving experience. The Stinger reflects a deep commitment to capturing the distinctive feel of classic sport sedans. Take a long, meandering ride in the Stinger and see how the right balance of passion and technology can reinvigorate your daily drive.

*部分功能與配備非標準配備，實際車色及規格配備以實車為準，詳情請洽KIA經銷商。



A DREAM CAR FOR RATIONAL PEOPLE

Are you torn between exciting, provocative cars that you've dreamt about from an early age and sensible cars that are a better fit for your everyday life? Rarely has a new car brought both of these extremes together so seamlessly. The Stinger is a car you can dream about all night, then hop into every morning for a drive that is sure to wake up your senses.

*部分功能與配備非標準配備，實際車色及規格配備以實車為準，詳情請洽KIA經銷商。



CLASSIC SIMPLICITY FOR PASSIONATE DRIVERS



From the low-slung driver's seat to intriguing details like the circular, aircraft-inspired air vents, Stinger's cockpit design draws heavily on classic sport sedans. Crucial information appears on a tidy supervision cluster flanked by the tachometer and speedometer, as well as through the optional Head-Up Display on the windshield. Secondary information appears on an 8-inch floating display.

*部分功能與配備非標準配備，實際車色及規格配備以實車為準，詳情請洽KIA經銷商。示意圖之影音多媒體螢幕為海外式樣，國內式樣為8吋影音多媒體螢幕。示意圖之內裝配置顏色與材質為海外式樣，國內式樣請以實車為準。



WHERE PERSONAL SPACE IS PARAMOUNT



Inside, the Stinger feels sporty, substantial and uncluttered. It's also spacious, particularly in the rear, thanks to its long wheelbase. Interior treatments include soft, luxurious Nappa leather seats on the GT version, while all models feature firm front and rear seats and bolsters.

Expansive 2nd row roominess The Stinger offers superior headroom, shoulder room and legroom compared to its major competitors, providing ample space for two or three passengers to sit comfortably and stretch out.

Wide sunroof Ready to feel the wind in your hair? A wide, tilting and gliding, one-touch sunroof is available. With the press of a finger, it lets in far more sunlight and fresh air than a conventional sunroof.

SUPPORTIVE BUT NOT OVERBEARING

The Stinger offers substantial stability management for a sports sedan, while giving the driver more choices as to how much or how little control to leave to the ECU. Drivers can choose from five drive modes, each with its own coordinated combination of dynamic characteristics. There is even a Launch Control mode that momentarily suspends ESC to ensure rapid acceleration with minimal wheel slip and maximum torque control.



※部分功能與配備非標準配備，實際車色及規格配備以實車為準，詳情請洽KIA經銷商。



8-speed automatic transmission

Smooth shifts are what you'll notice first with the 8-speed rear-wheel drive automatic transmission. Its algorithms ensure quick and seamless gear changes while helping to maximize fuel efficiency.

INGENUITY THAT PACKS A PUNCH

Stinger powertrains set a higher standard for longitudinal, rear-wheel-drive orientation, leveraging technology to achieve remarkable combustion efficiency. Each powerplant is designed to offer the thrilling feel of rear-wheel propulsion when you step on the accelerator, even at low engine speeds. An 8-speed automatic transmission redefines smoothness, while the Stinger also offers a game-changing twist on gran turismo traditions with optional road-taming all-wheel drive.



3.3 T-GDI engine A twin turbocharger helps this top-of-the-line V-6 engine achieve considerable torque over a broad rpm range. The exhaust manifold is integrated with the cylinder head for added power, and an electronic thermostat helps provide precise temperature control.

2.0 T-GDI engine A twin-scroll turbocharger boosts low- to mid-rev efficiency while newly applied technologies provide phenomenal combustion efficiency. The engine produces maximum power output of 255 ps at 6,200 rpm and maximum torque output of 36 kgm from 1,400 to 4,000 rpm.



*部分功能與配備非標準配備，實際車色及規格配備以實車為準，詳情請洽KIA經銷商。



INTELLIGENT DISTRIBUTION OF POWER



Electronic Stability Control (ESC) ESC ensures optimal braking performance and directional control by automatically delivering the right amount of braking force to each wheel based on evaluation of engine torque and driving circumstances.

Drive Mode Select (DMS) The Stinger's DMS includes five modes, accessible from a dial behind the shift lever, that change the driving characteristics by automatically adjusting how the engine, transmission, suspension, steering and AWD operate, while even altering the engine sound.

*部分功能與配備非標準配備，實際車色及規格配備以實車為準，詳情請洽KIA經銷商。

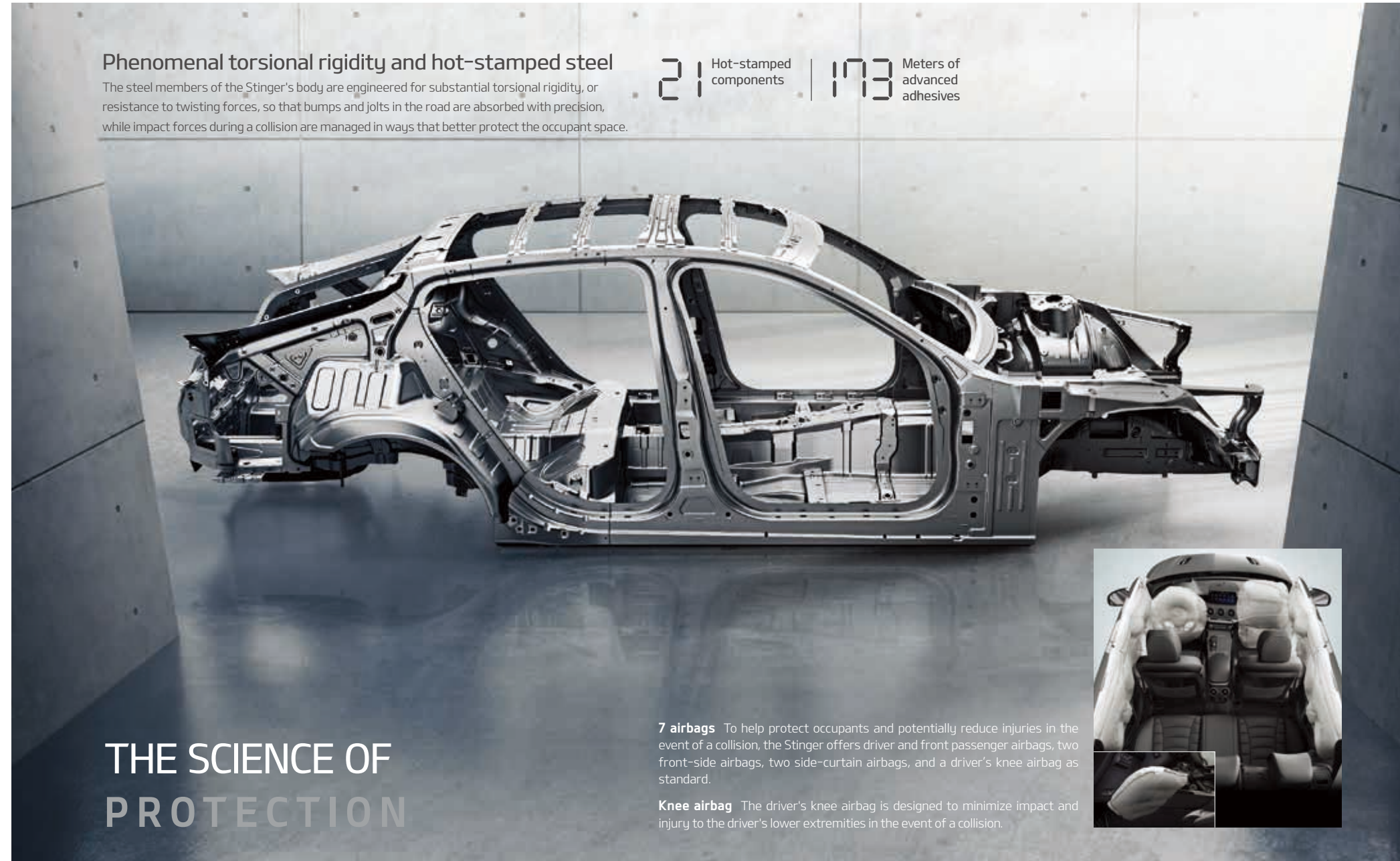

Phenomenal torsional rigidity and hot-stamped steel

The steel members of the Stinger's body are engineered for substantial torsional rigidity, or resistance to twisting forces, so that bumps and jolts in the road are absorbed with precision, while impact forces during a collision are managed in ways that better protect the occupant space.

21 Hot-stamped components

173 Meters of advanced adhesives

THE SCIENCE OF PROTECTION

7 airbags To help protect occupants and potentially reduce injuries in the event of a collision, the Stinger offers driver and front passenger airbags, two front-side airbags, two side-curtain airbags, and a driver's knee airbag as standard.

Knee airbag The driver's knee airbag is designed to minimize impact and injury to the driver's lower extremities in the event of a collision.



INTUITIVE PROBLEM-SOLVING

DRIVE WISE is Kia's ADAS (Advanced Driver Assistance System) technology initiative dedicated to delivering driving pleasure and the utmost in occupant and pedestrian safety by taking over the tedious and complex tasks traditionally left to drivers. The Stinger offers many DRIVE WISE assistance technologies that use advanced sensor and processing technology to help make driving as safe and convenient as possible.



Safety

DRIVE WISE recognizes surrounding risk factors at an early stage. Its intrinsic alarm system is designed to improve safety by preemptively reducing the risk of accidents through timely interventions.



Convenience

DRIVE WISE provides customized information based on analysis of surroundings and the driver's actions. The goal is to prevent undesirable operation, guarantee the driver's autonomy, and maximize convenience.



Efficiency

DRIVE WISE is dedicated to supporting more efficient driving in ways that respect the driver's time and economic interests.

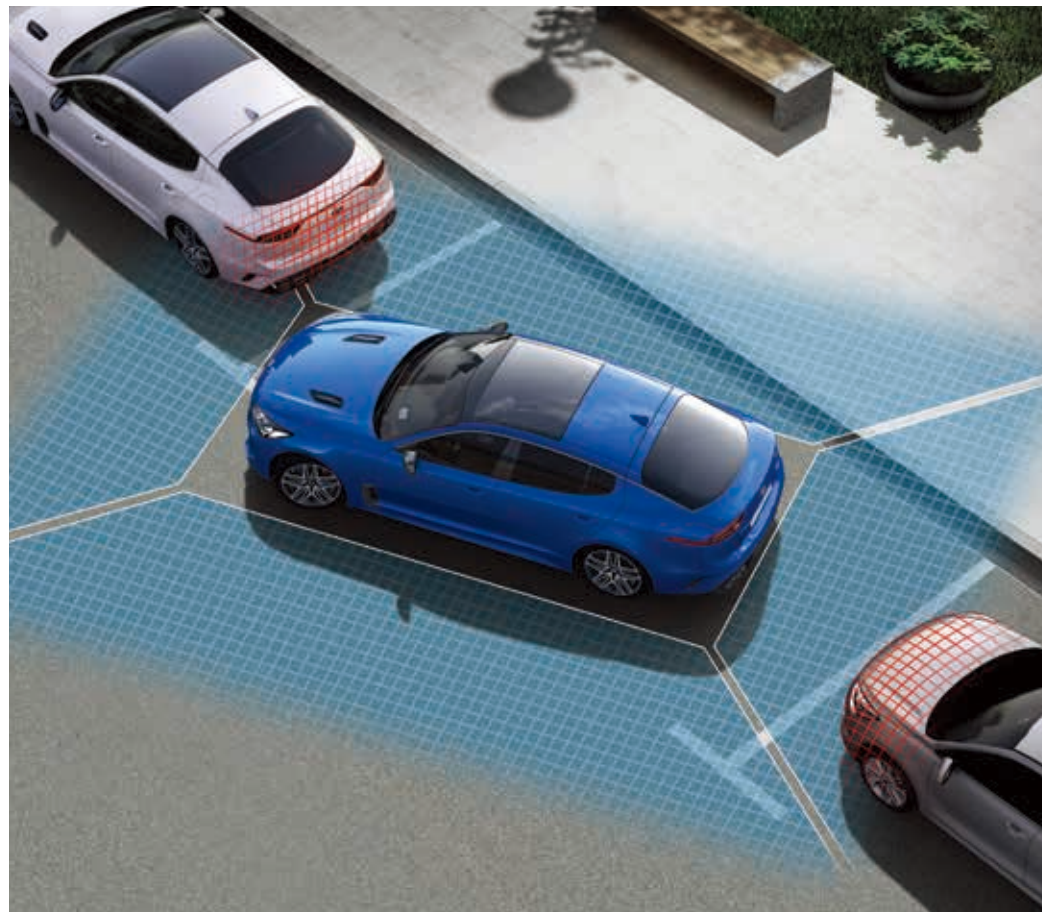

Around View Monitor (AVM) with Parking Guidance

This intuitive system combines four wide-angle images from cameras at the front, rear and sides of the vehicle to give you a comprehensive bird's eye view of your surroundings while parking or moving at speeds below 20 km/h.



Parking Distance Warning-Forward/Reverse (PDW-F/R)

To help you park safely and confidently, PDW-F/R uses ultrasonic sensors mounted on the front and rear bumpers to warn of any obstacles. These warnings can help you position the wheels properly when maneuvering the Stinger into tight spaces.



Forward Collision-Avoidance Assist (FCA)

FCA uses a front view camera and front radar to detect vehicles, pedestrians or cyclists ahead. By warning and braking automatically, it can help you avoid or reduce the severity of an accident.



Lane Keeping Assist (LKA)

When you start drifting out of your lane, LKA alerts you and even steers you back to your intended lane of travel.



Blind-Spot Collision-Avoidance Assist (BCA)

If you start to change lanes and BCA detects a vehicle in the blind spot, it will warn you, and can even apply differential braking to avoid a collision. It also alerts you to approaching vehicles when exiting a parallel parking space.



Blind-Spot View Monitor (BVM)

Activate the turn signal and BVM will present live video footage on the instrument cluster of other vehicles in the blind spot.



**CONFIDENCE
GROUNDED IN PHYSICS**

*部分功能與配備非標準配備，實際車色及規格配備以實車為準，詳情請洽KIA經銷商。

INFORMATION IN CLEAR SIGHT

Designing the ideal driving experience requires packaging all of today's technologies in a clear, simple and satisfying way. The Stinger boasts a wealth of high-tech driving, safety and entertainment features that did not exist in the old days of gran turismo motoring. Yet the cockpit design is simple and classic, allowing the driver to focus on the road. Standardly equipment like the Head-Up Display and floating 8-inch screen convey information in an ingenious yet tasteful way.



Head-Up Display (HUD)

With the customizable Head-Up Display (HUD), key driving information is discretely projected onto the windshield in your line of sight so that you can safely focus on the road ahead. Visible day or night, the height-adjustable display appears to float just in front of the car.



7" supervision cluster Vital vehicle and driving information appear in a larger, more vivid and higher-definition format on the optional 7-inch TFT LCD supervision cluster located between the tachometer and the speedometer.

Wireless smartphone charger Charge a compatible mobile phone wirelessly on the charging pad located at the front of the center console. An orange display indicates charging in progress while green indicates a full charge. You will be alerted when exiting the vehicle if a device is left on the charging pad.



SUBLIME SOPHISTICATION

You spend a lot of time in your car. So why not tailor the Stinger's interior to match your take on the ideal modern gran turismo? The Stinger has a surprisingly long list of impressive standard features, but for the utmost enjoyment, choose from a variety of premium comfort, entertainment and convenience options.



15-SPEAKER Harman/Kardon premium sound

The optional Harman/Kardon sound system includes subwoofers that resonate in hollow parts of the frame and body. Clari-Fi technology enhances digitally compressed music while Active Sound Design augments acceleration, shifting and suspension sounds for an enhanced driving experience.



Paddle shift levers Standard paddle shift levers let you make quick gear changes for the 8-speed automatic transmission without taking your hands off the steering wheel. It's a simple way to access more torque on short notice or choose your own shift points during vigorous driving.



Electric Parking Brake (EPB) An electric parking brake offers quick, secure activation without the effort required by traditional mechanical brake levers. Pull on the EPB switch on the center console to activate the parking brake. Auto Hold mode temporarily maintains the vehicle at a standstill even if the brake pedal is released.



Ventilated front seats Available ventilated front seats provide cool, soothing airflow on hot days, and more effective and thorough heating on cold days. Both the seat cushion and the seatback feature airflow perforations to keep more of the body in a state of comfort.



3-zone climate control A standard dual-zone full auto temperature control system along with rear seat climate control gives the driver and all passengers separate controls, allowing people with different climate needs to ride together in comfort.



Integrated Memory System The Integrated Memory System saves two presets for driver's seating positions, outside rear-view mirrors, Head-Up Display and cluster display. It's a simple way to keep the Stinger totally personalized, yet flexible enough to make another driver feel at home.



Remote Start-up For those in extremely hot climates, the Remote Start-up system enables the car to be started from a distance with a press of a button on the smart key. This means the air conditioning can be turned on, cooling down the in-cabin temperature before driver and passengers get in the car.

► Side-bolster adjustment

Optional side-bolster adjustment for the 8-way power driver seat lets you choose a setting that offers maximum support and comfort by twisting the seat controls on the side of the base of the seat.

► 4-way Air Cell Lumbar Support

Optional Air Cell Lumbar Support for the 8-way power driver seat lets you reposition areas of resistance in the seatback, up-and-down and side-to-side, for maximum comfort and support.

► Cushion extension

To help relieve fatigue, an optional thigh extension for the driver moves the front edge of the seat base forward, supporting a larger area of the driver's thighs.





ONE SPIRIT THREE FACES

Every Kia Stinger artfully captures the most desired elements of classic motoring in a five-door sports sedan designed to excel in the real world. From the graceful EX, to the invigorating GT Line, to the exhilarating GT, every Stinger offers driving enjoyment, a spacious interior and forward-thinking technology. Exclusive GT Line and GT exterior trim elements, interior options and performance features give these versions an especially unique personality.

*部分功能與配備非標準配備，實際車色及規格配備以實車為準，詳情請洽KIA經銷商

DEEPLY PERSONAL ALLURE

The inviting Stinger interior reflects the spirit of the gran turismo concept. Rich, luxurious tones complement the bold exterior colors. Contrast stitching and real aluminum add a refined touch. Choose Nappa leather on the GT, pure leather on the GT Line, and the EX.

Center Console Garnish



EX
Saturn Black Interior



GT Line
Saturn Black Interior

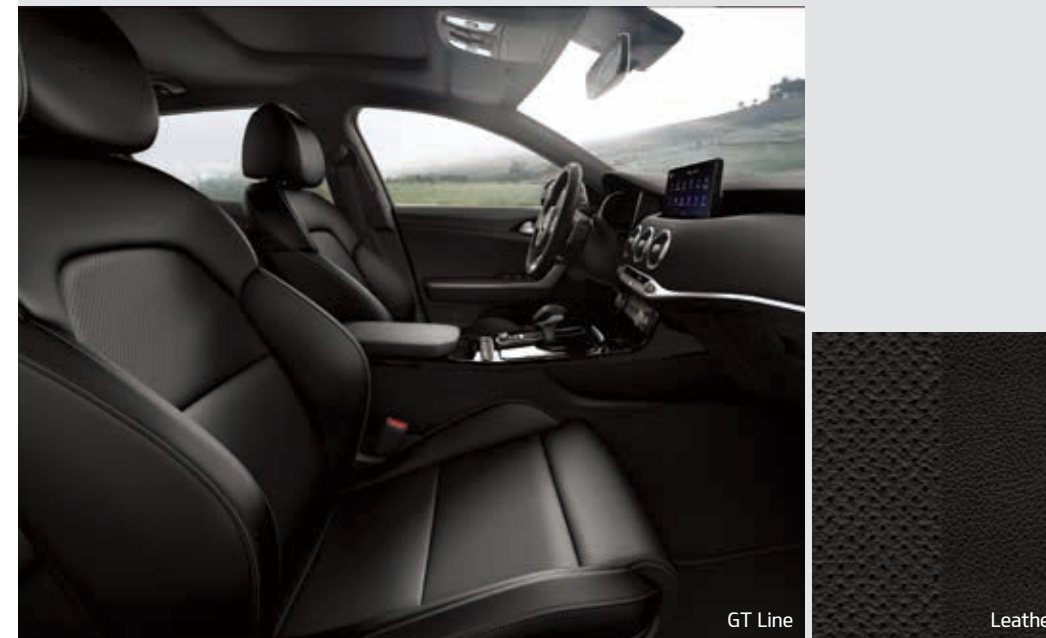

GT
Suede Package

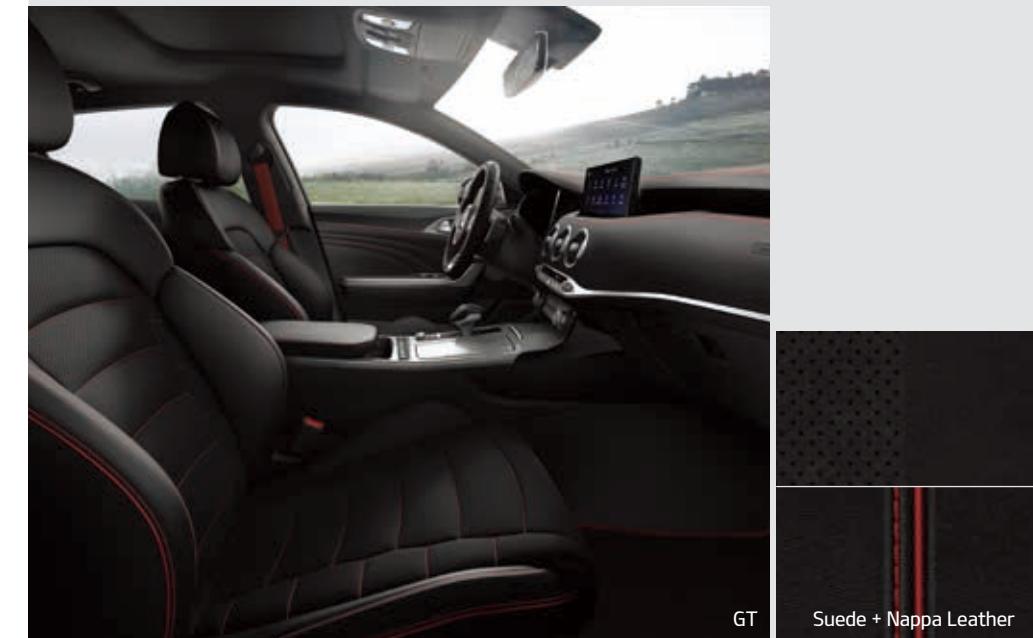

Red Color Package

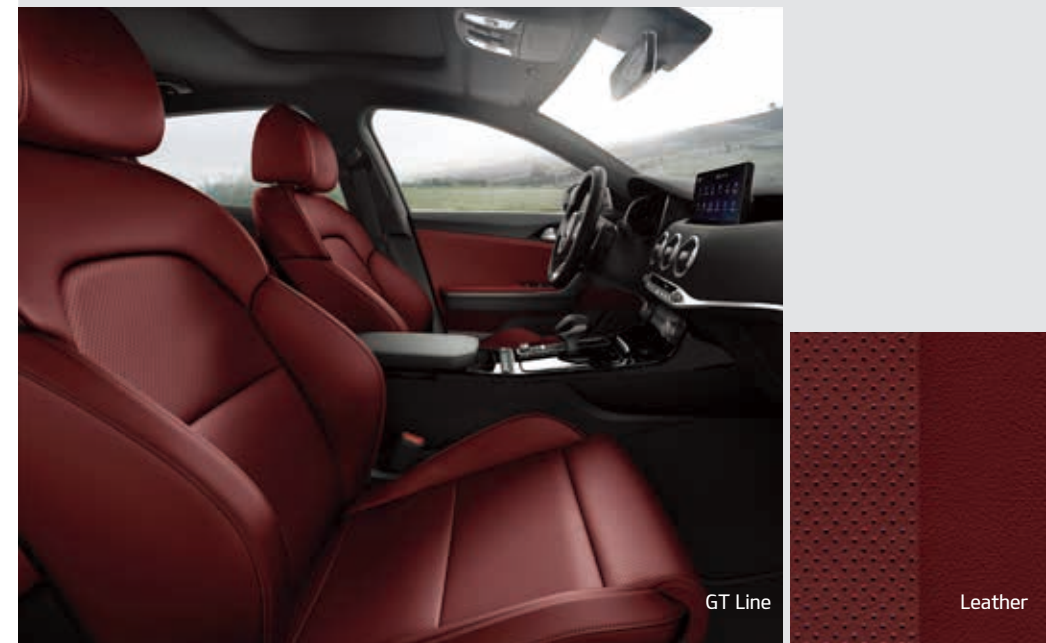

Red Color Package

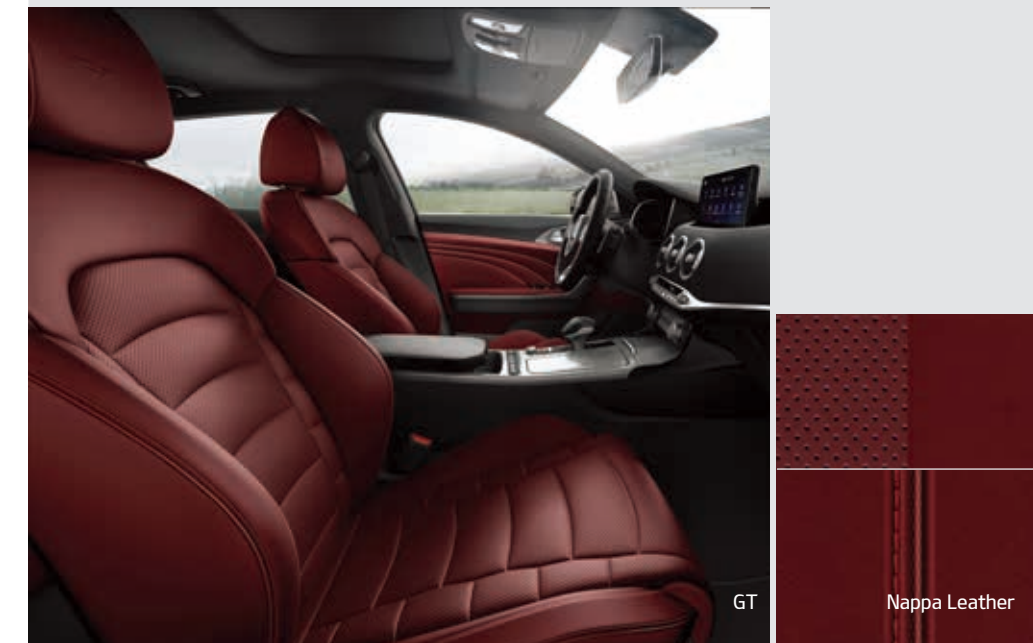

※部分功能與配備非標準配備，實際車色及規格配備以實車為準，詳情請洽KIA經銷商。示意圖之影音多媒體螢幕為海外式樣，國內式樣為8吋影音多媒體螢幕。示意圖之內裝配置顏色與材質為海外式樣，國內式樣請以實車為準。

Exterior Body Colors



225/45R
18" Alloy Wheel (EX)

225/40R (Front) | 255/35R (Rear)
19" Alloy Wheel (GT Line/GT)

※部分功能與配備非標準配備，實際車色及規格配備以實車為準，詳情請洽KIA經銷商。

Technical Specifications

		2.0 EX / 2.0 GT Line		3.3 GT AWD	
Engines		2.0 T-GDI engine		3.3 T-GDI engine	
Displacement	cc	1,998		3,342	
Max. power	ps/rpm	255 / 6,200		366 / 6,000	
Max. torque	kg-m/rpm	36 / 1,400-4,000		52 / 1,300-4,500	
Performance					
0-100 km/h	seconds	6.0		4.9	
80-120 km/h	seconds	4.4		3.3	
Top speed	km/h	240		270	
Cargo Capacity					
Trunk volume (VDA)	ℓ	406-1,114			
Dimensions					
Overall length	mm	4,830			
Overall width	mm	1,870			
Overall height	mm	1,400			
Wheelbase	mm	2,905			
Head room	Front	mm	974		
	Rear	mm	939		
Leg room	Front	mm	1,083		
	Rear	mm	925		
Shoulder room	Front	mm	1,433		
	Rear	mm	1,391		

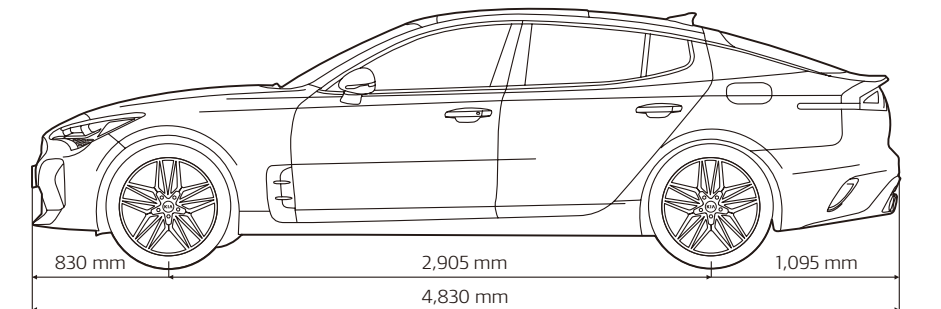
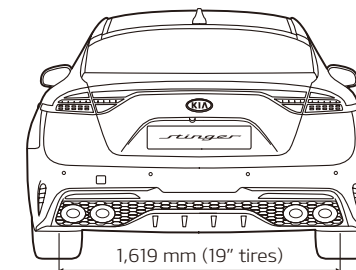
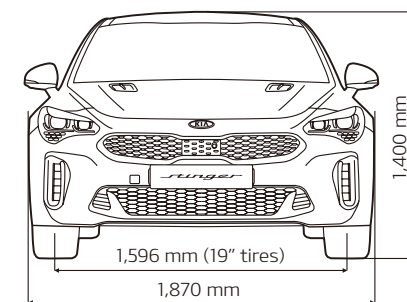

The Power to Surprise

