

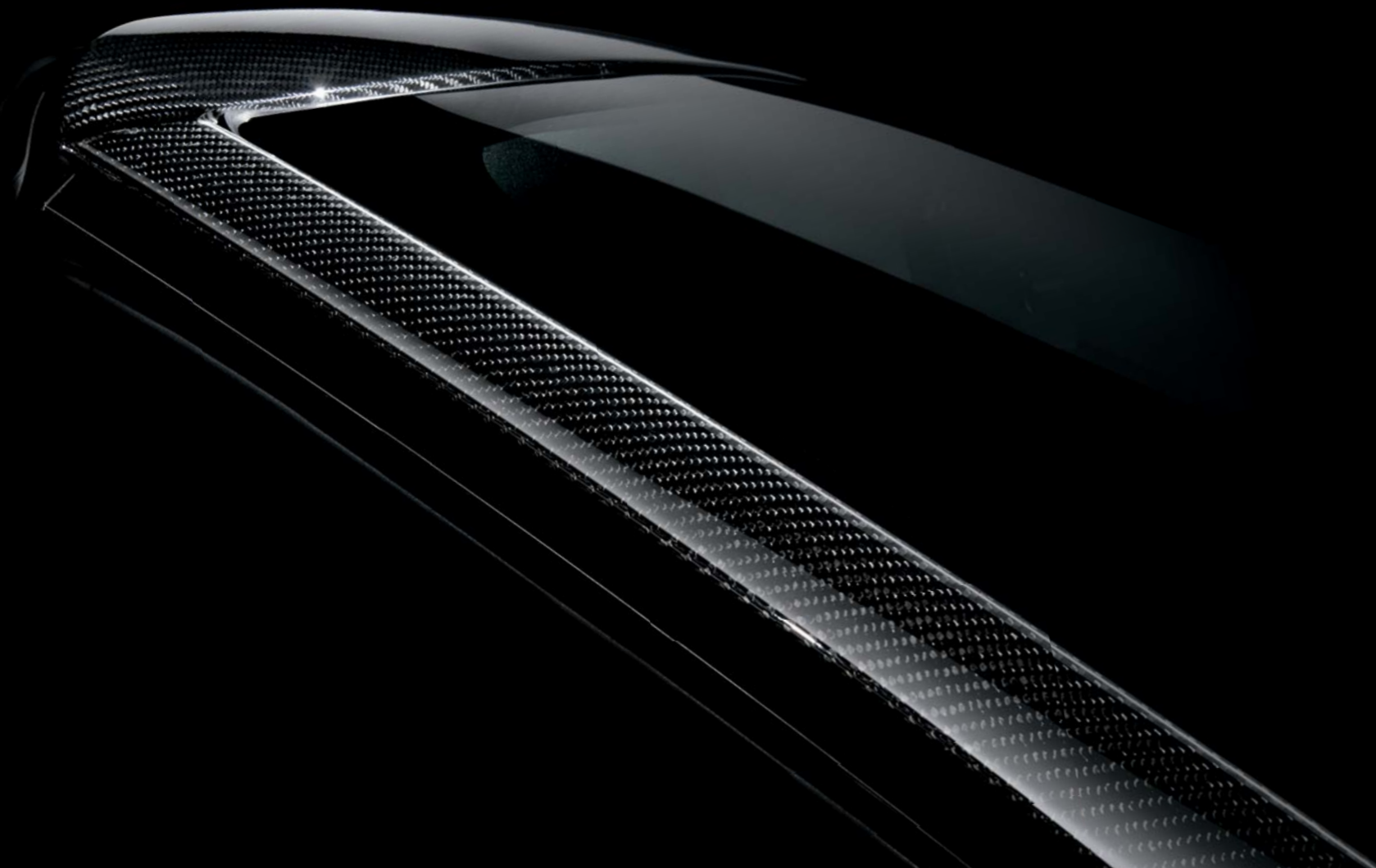

4C *Spider*

Alfa Romeo



4C Spider







Seduction under open skies

Introducing the Alfa Romeo 4C Spider, the elegant open top alternative to the Alfa Romeo 4C Coupé. With the roof off you'll experience total freedom, a thrilling drive and the ultimate on-road sensation.



Raw emotion

The forms, the lines, the road handling, the racing DNA and the close relationship with the Coupé mean that the Alfa Romeo 4C Spider is the perfect fusion of emotion and technology.

The 33 Stradale, from which the 4C was designed, is considered to be one of the most beautiful cars of all-time.

Renowned for its performance-oriented design philosophy, the 33 Stradale was packed with innovative technologies - including a brand new chassis mounted on a structure that combined magnesium alloys and steel tubes, inspired by aeronautical technology.







The Spider has evolved

The open air feel of the Alfa Romeo 4C Spider is the result of a natural "evolutionary development" that originates from the Coupé version. Its creation is based on very specific technological and stylistic choices that best enhance the feeling of freedom without forsaking any of the Alfa Romeo 4C Spider's sporting DNA. The initial concept is the same: the vehicle's technical specifications, performance and style all combine to guarantee the perfect balance between form and mechanics.

The Alfa Romeo 4C Spider goes one step further by refining a few of the components and processes. The transformation of the rear endows it with greater strength and muscularity. The redesigned rear engine cover leaves room for a bonnet and is shaped to house the air intakes, beneath which one can sense the presence of the car's beating heart.

The elegant and sharp sculpted design enhances the technical features.

Open air thrills

The Alfa Romeo 4C Spider offers a unique driving experience in terms of both speed and road handling. The soft top is incredibly light, strong and easy to remove, giving great protection even at high speeds.



The genuine article

Getting into an Alfa Romeo 4C Spider envelops you in a sophisticated world of high performance. By eliminating the superfluous, every single element of the Alfa Romeo 4C Spider has purpose. It is the designers' discipline that gives the driver a genuine sports car experience. The interior of the Alfa Romeo 4C Spider stands out for its carbon fibre body cell, but that's not all.

There's an instrument panel with TFT technology, a sports steering wheel, aluminium foot rests and pedals and dashboard controls slanted towards the driver. They're all elements that help to emphasise the Alfa Romeo 4C Spider's racing heritage.

The sports seats (available in standard cloth or optional leather or leather and microfibre) match the expectations of the most discerning driver. The optional leather dashboard with contrasting stitching and carbon fibre air vents are yet another interior enhancing detail.







Lightness and performance

The creators of the Alfa Romeo 4C have been bold, utilising ultralight, versatile materials such as carbon fibre, aluminium and composites. The result is a sports car with remarkable agility and supercar performance, just as fast as its Coupé stablemate, the Alfa Romeo 4C Spider weighs less than 1,000 kilograms and delivers an excellent weight-to-power ratio. This means that the agility and performance of the Coupé are also achieved by the Alfa Romeo 4C Spider.

Beautifully crafted

The Alfa Romeo 4C Spider is built with the same materials you'll find in a Formula 1 car. High performance carbon fibre, aluminium, and low-density composites are perfectly combined to create a lighter, sleeker sports car.

Carbon fibre - a particularly light and resilient material - characterises Alfa Romeo 4C, making it unique with a chassis built with the same materials you'll find in a Formula 1 car. The use of carbon fibre on the Alfa Romeo 4C Spider extends to the windscreen frame and to the roll bar cover (the latter optional).

The Alfa Romeo 4C Spider's unique alloy wheels are milled from just one piece of aluminium. Aluminium - lightweight and strong, this has been used to make the engine, the rear engine mounting and the front cells.

SMC - an innovative low-density composite material is used for the outer body and ensures greater stability than traditional aluminium. It also results in a weight reduction of 20% compared to sheet steel.

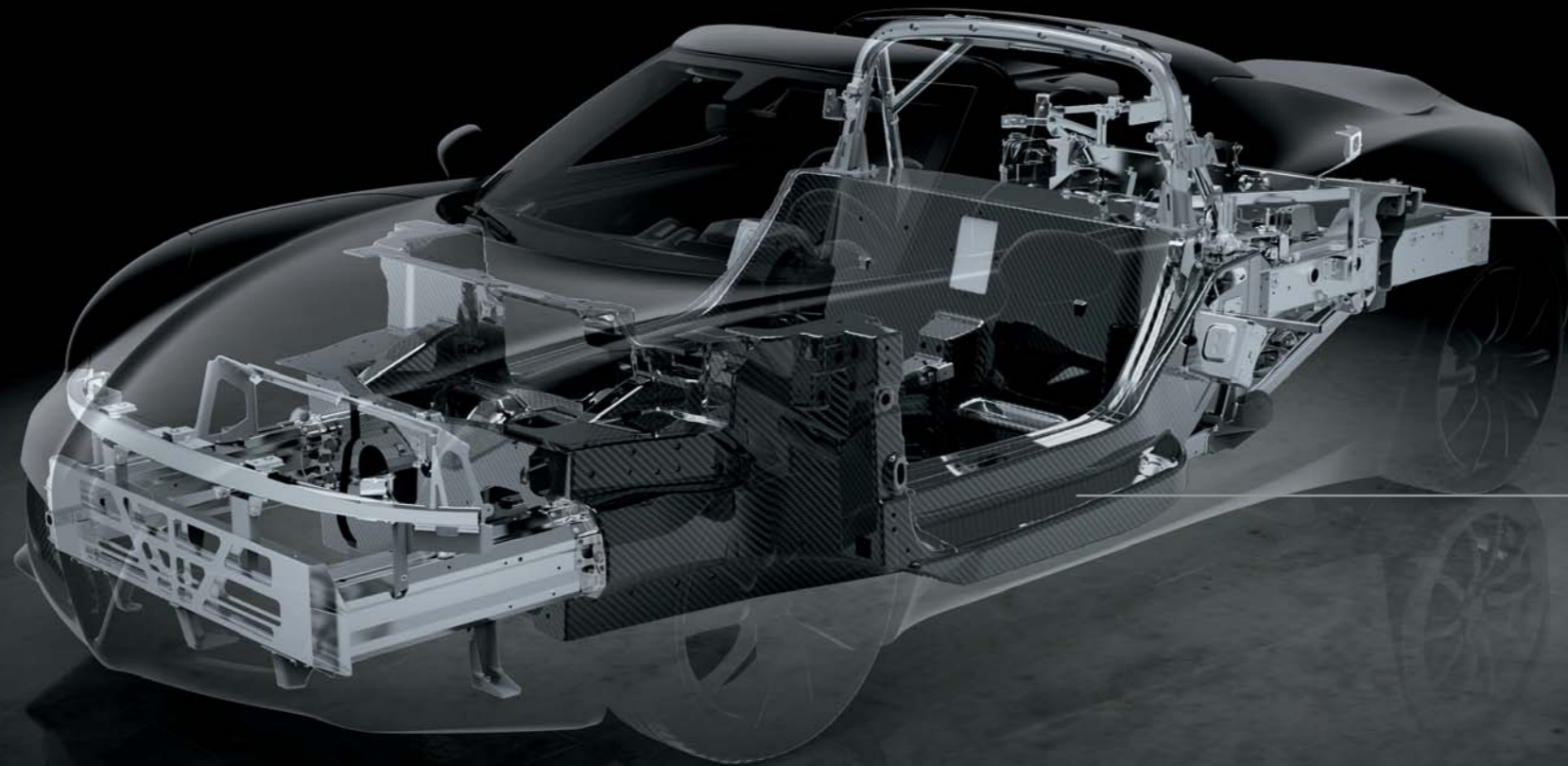
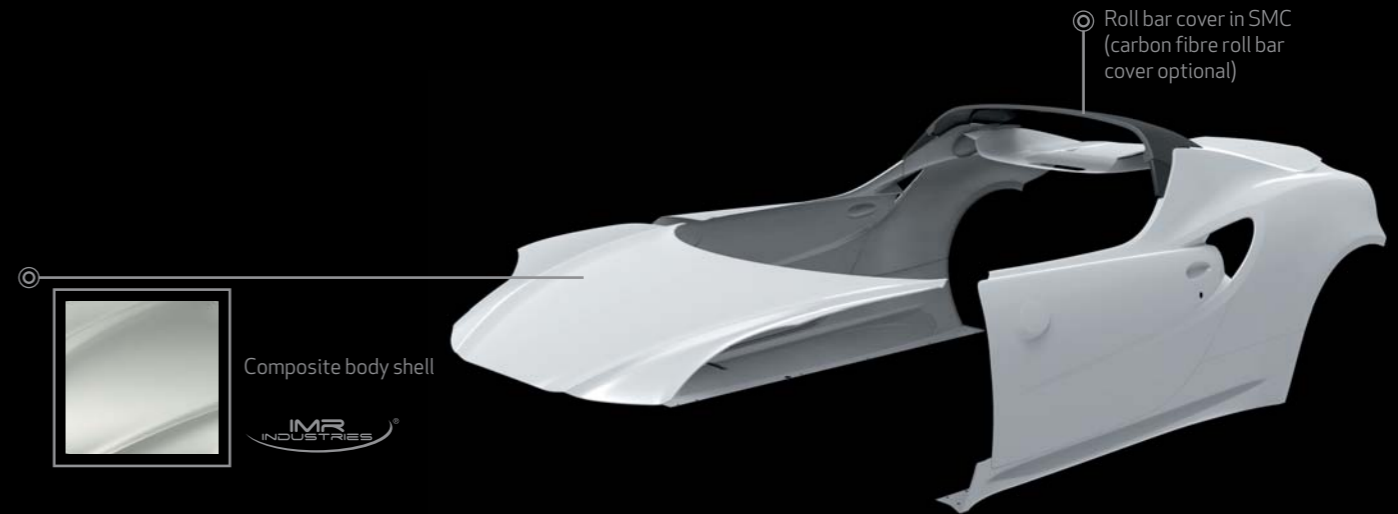

Sculpted and aerodynamic

The Alfa Romeo 4C Spider's core architecture is the result of a very specific design rationale: rear traction and central engine position for perfect weight balancing; a straight two seater with a pure sports cockpit.

Alfa Romeo 4C exploits all the dynamic advantages of rear-wheel drive – better grip in acceleration and faster cornering. All coming together to give the driver the most intense driving experience.

The centrally positioned aluminium engine means the car can be lighter because there's no need for a drive shaft. This optimises weight distribution ensuring the Alfa Romeo 4C Spider has extremely sharp handling.

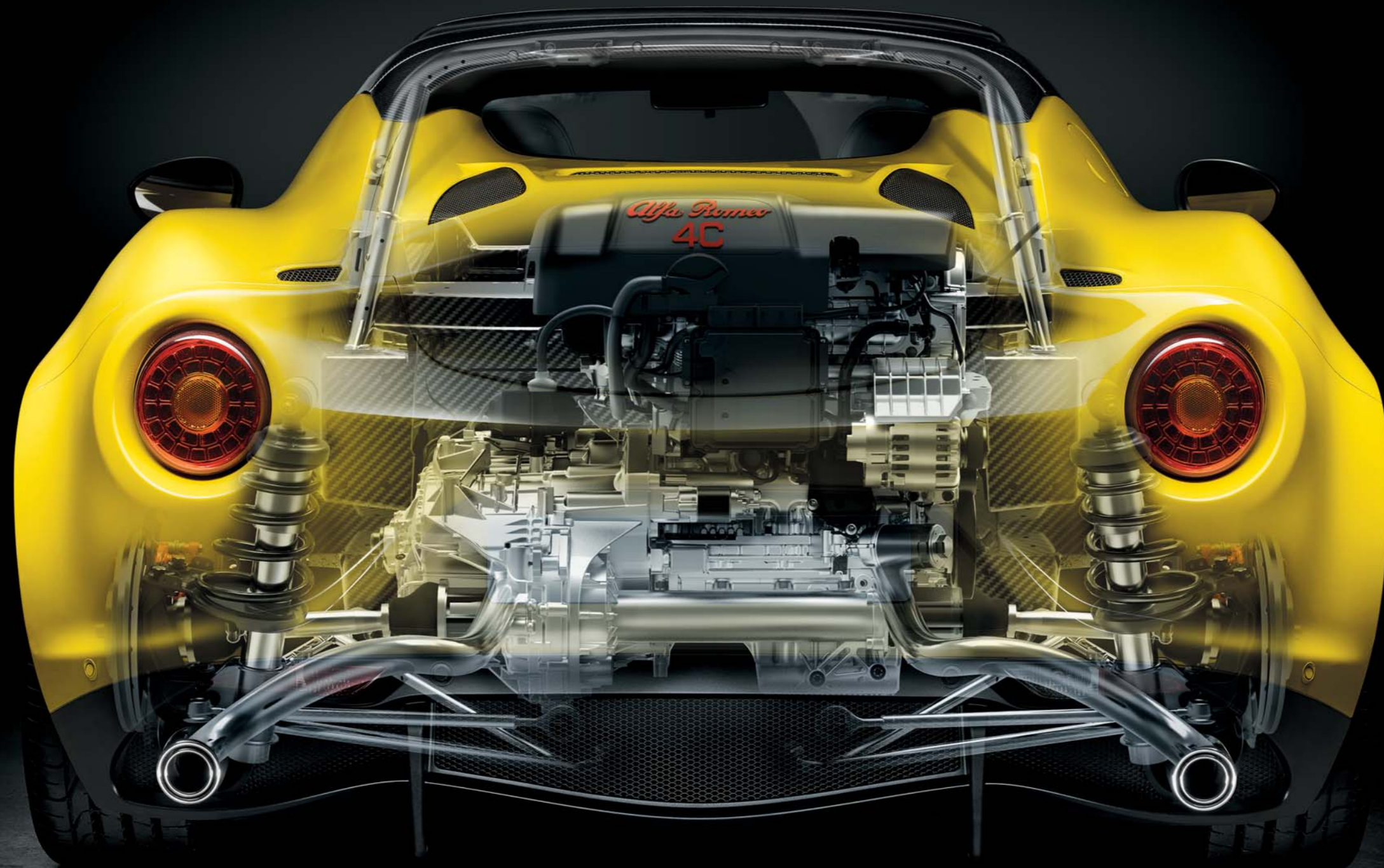



Pure power and freedom

At the heart of the Alfa Romeo 4C Spider is a 1750cc 240bhp Turbo Benzina (petrol) engine that roars with power. Experiencing this with the open top is like nothing else on earth.

4 cylinders with an aluminium block and structure, a next generation turbocharger, ultra high-pressure direct fuel injection, two continuously variable valve timing units, scavenging technology and double clutch, enable this 1750cc engine to deliver unprecedented sporting performance. The specific torque and power ratings are at the top in its category. Maximum power of 240bhp is reached at 6,000 rpm, confirming the unit's extraordinary elasticity and dynamism. Pick-up and acceleration are exceptional: the Alfa Romeo 4C Spider accelerates from 0 to 62 mph in just 4.5 seconds and boasts a top speed of over 160 mph.

This impressive level of performance has been achieved with minimum impact on the environment. Thanks to multiple injection control and advanced anti-friction and energy loss reduction systems, the emissions of the Alfa Romeo 4C fall well within the strict limits of Euro 6.



SCAVENGING TECHNOLOGY

The Alfa Romeo 4C's advanced scavenging technology maximises torque at low engine speeds and delivers more power in response to driver input. The control unit determines valve overlap times and angles with great precision to create a through-flow of air from the inlet to the exhaust manifolds. By improving the scavenging of the combustion chamber, this direct flow increases combustion efficiency as well as turbine speed and reduces turbo-lag.

TURBOCHARGER

To boost torque at low engine speeds, the engine is also equipped with a new generation turbocharger and a pulse converter exhaust manifold.

Both manifold and turbine are made of microcast steel to withstand the very high operating temperatures (over 1000°C): this condition is essential to reduce fuel consumption under medium-high speed and motorway driving conditions.

The wastegate valve is another essential device for engine efficiency. This adjusts turbo pressure control logic according to the vehicle's dynamic driving settings, minimising pumping losses.

AFTER-RUN PUMP

Like all top competition cars, the Alfa Romeo 4C uses an automatic cool-down system to protect its turbocharger. Switching off the engine would normally cause the immediate stoppage of oil circulation, leaving the oil in the turbocharger to stagnate at very high temperatures: the thermal stress suffered by the oil causes a loss of lubricating capacity and also leads to the formation of residues that can damage the engine. To prevent this, Alfa Romeo has introduced an after-run pump. This electric pump is automatically controlled by the ECU and keeps oil circulating through the turbocharger until it has cooled sufficiently.

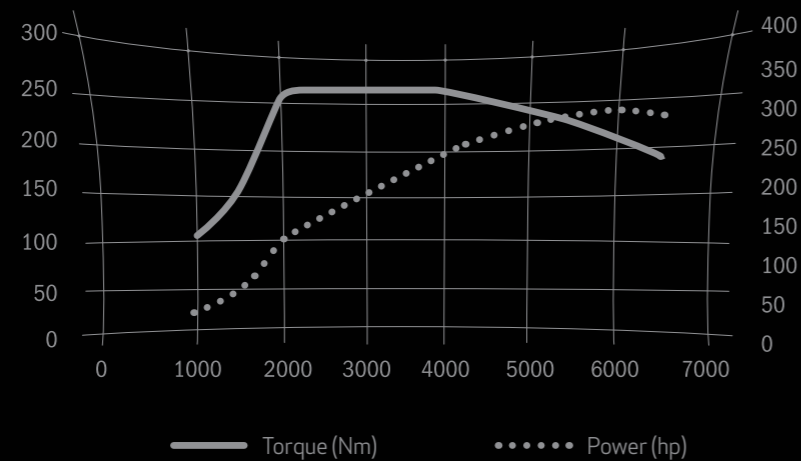

0-62 mph
in 4.5 seconds

The Alfa Romeo 4C Spider's impressive acceleration is enhanced by a highly developed ALFA TCT 6 speed gearbox with a dry Twin Clutch Transmission system. This gives the Alfa Romeo 4C Spider the instant power of a sequential shift with all the convenience of an automatic. From a conceptual standpoint, the system works as two gearboxes in parallel, each of which with its own clutch so that two gears are always engaged. The higher gear is already engaged when the lower one is released, thus eliminating power gaps.

The ALFA TCT gearbox also features an all-new control software that ensures the fastest possible gearshift in all driving conditions. Gearshifts are more aggressive in the sporting performance modes, and drivers can clearly feel the new gear engaging, as on a racing car. Moreover, on bends, gearshifts are completed in the smoothest way possible to maintain stability.

Activate the Alfa Romeo 4C Spider's Launch Control and as soon as the brake is released, the system automatically controls the gearbox, traction and power to maximise acceleration from a standing start. Activate the Launch Control and as soon as the brake is released, the system automatically controls the gearbox, traction and power to maximise acceleration from a standing start.



It's all in the D.N.A.

Four configurations in one device to respond to the needs of a very super sports car. Borne out of our racing expertise, the Alfa Romeo 4C's D.N.A. selector is designed to adapt to different driving conditions and styles, ensuring a satisfying, intuitive experience every time.

Dynamic. This setting will deliver great driving performance. Engine control parameters are configured to reduce gearshift times by up to 25% compared to Natural mode. The ESC system permits a certain angle of drift and only intervenes if the steering wheel position and drift angle could put the car at risk.

Natural. This is your everyday mode. Gearshift parameters are configured for maximum comfort. The Auto-Up function shifts up to the next gear when engine speed approaches the permitted upper limit, while the Auto-Down function shifts down as soon as engine speed falls below 1000rpm. Finally, the Alfa Q2 differential operates in soft mode and only cuts in if one of the rear wheels suffers a significant loss of grip.

All-weather. Select this mode to ensure maximum safety under adverse weather conditions.

In All-weather mode, the car responds to accelerator input very gently. The ASR system selects special engine and brake control logic and, in the event of loss of grip, modifies power to match road speed and prevent skidding that could otherwise be difficult to control.

Alfa Race. The most extreme performance mode is engaged by moving the mode selector to Dynamic and holding it there for a few seconds. In Alfa Race mode, ESC stability control is normally deactivated and only intervenes to prevent loss of control under heavy braking. Traction is managed exclusively by means of the accelerator pedal while the Launch Control system combined with the TCT ensures supercar take-off and acceleration.



4C

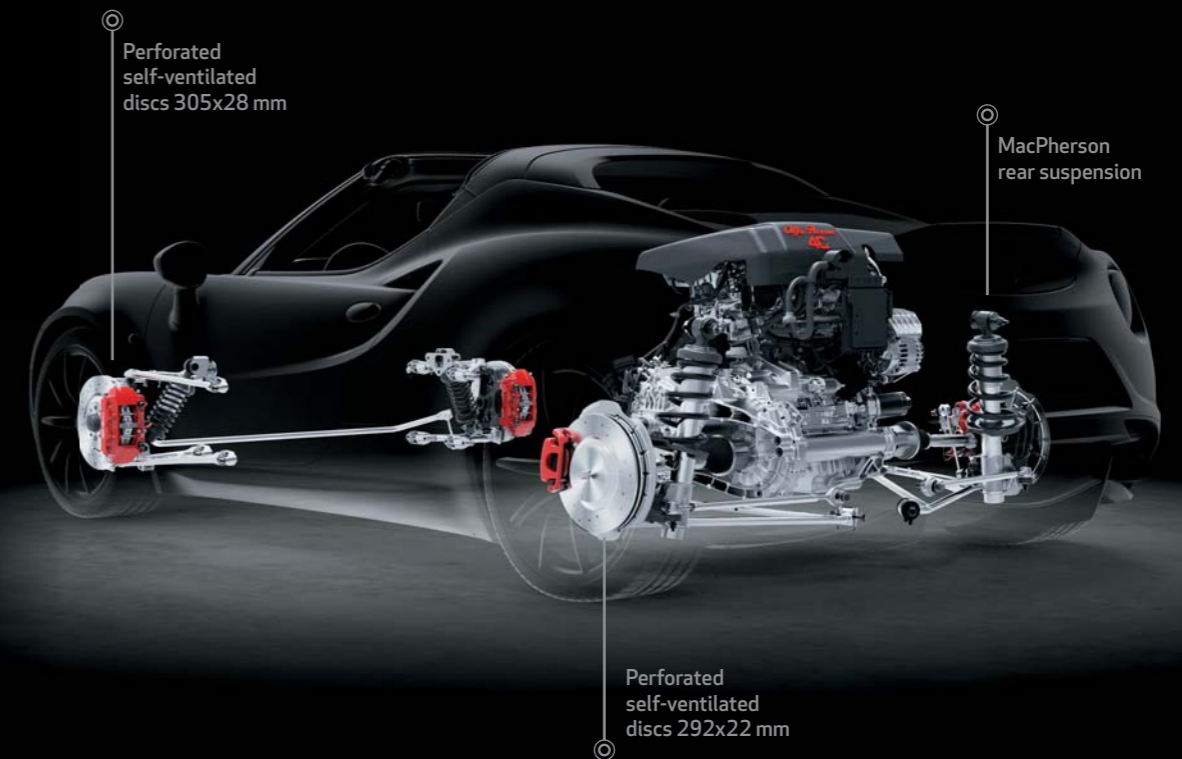

Freedom with control

With self-ventilating brake discs and tyres with different diameters, the refined Alfa Romeo 4C Spider adopts still more technical advances tested in racing. The vehicle's ride control system maximises weight reduction and simply adds to its performance.

The double wishbone suspension is configured to give you direct and unfiltered feedback from the road. At the rear, advanced MacPherson suspension ensures superb road holding and driving fun, even in extreme manoeuvres. For lightness and strength, both front and rear suspension systems combine aluminium with steel.

4 self-ventilating perforated discs with Brembo fixed 4 piston calipers on the front discs means you can bring the car to a standstill in just 36 metres when travelling at 62 mph.

To ensure maximum grip, the Alfa Romeo 4C Spider is fitted with specially made Pirelli tyres, all with different diameters 17"- 18" (as standard) or 18"-19" (optional) and all uniquely bearing the 'AR' inscription. By using a special rubber compound these exclusive tyres enhance maximum lateral acceleration and response times whilst reducing braking distance.





The team of expert technicians dedicated to its production have undergone 500 hours of special training and have been immersed in its development. At the end of the assembly stage, every Alfa Romeo 4C Spider is checked and double-checked to ensure the highest levels of craftsmanship and precision have been maintained. It is then handed over to our expert test drivers for dynamic performance testing under a wide range of conditions.

Loyal to style and Alfa Romeo technological developments, Alfa Romeo 4C Spider is made in the Maserati plant in Modena, Italy, to guarantee the extremely high level expert craftsmanship that is the fullest and most authentic expression of Italian-made quality.

Excellence made in Italy



TECHNICAL SPECIFICATIONS

ENGINE	
Type	1750 cc, aluminium, 4 cylinders, turbocharged
Position	Central
Orientation	Transverse
Displacement (cm ³)	1742
Maximum power hp (kW-EC) at rpm	177 (240) 6000
Maximum torque Nm at rpm	350 between 2200 and 4250
DRIVING MODE SELECTOR	
Type	Evolved Alfa D.N.A.
Positions	Dynamic, Natural, All-weather, Alfa Race
TRANSMISSION	
Gearbox	ALFA TCT (dry Twin Clutch Transmission) with paddle controls and Launch Control
Number of gears	6 + R
Drive	Rear
Differential	Electronic Q2
CHASSIS	
Type	Carbon fibre monocoque
Front suspension	Double wishbone
Rear suspension	Evolved MacPherson
Front brakes (mm)	Dual-cast, perforated, self-ventilated 305x28 discs with Brembo fixed 4 piston calipers
Rear brakes (mm)	Perforated, self-ventilated 292x22 discs
Standard front tyres	205/45 R17
Standard rear tyres	235/40 R18
STERING	
Steering box	Rack and pinion
PERFORMANCE	
Acceleration 0 - 62 mph (secs)	4.5
Braking distance 62 - 0 mph (m)	36
Top speed (mph)	160
Maximum deceleration under braking (g)	1.25
Maximum lateral acceleration (g)	1.1
CAPACITIES - WEIGHTS	
Unladen weight (kg)	940
Fuel tank with Fast Fuel (litres)	40
FUEL CONSUMPTION & EMISSIONS (according to Directive 1999/100/EC)	
Urban cycle mpg (l/100 km)	28.0 (10.1)
Extra-urban cycle mpg (l/100km)	55.4 (5.1)
Combined cycle mpg (l/100 km)	40.9 (6.9)
CO ₂ emissions (g/km)	161
Emission standard	Euro 6
DIMENSIONS	
Number of seats	2
Length (mm)	3989
Width (mm)	1864
Height (mm)	1183
Wheelbase (mm)	2380
Luggage compartment capacity (litres)	110



1750 cc, aluminium, 4 cylinder, turbocharged engine

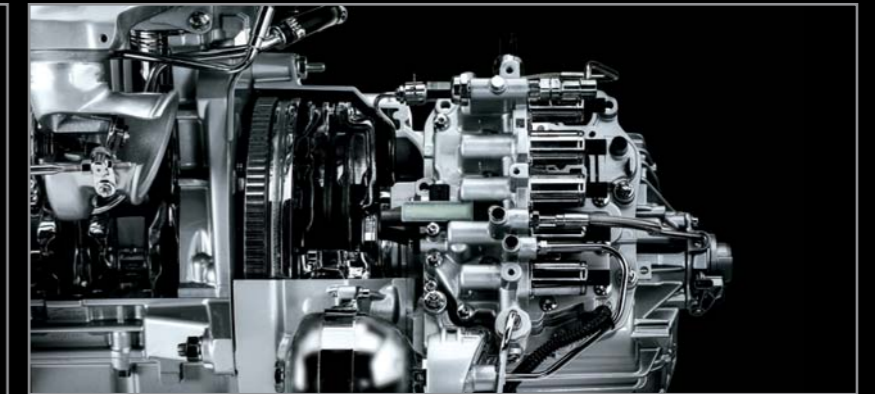

ALFA TCT (Twin Clutch Transmission) gearbox with paddle controls and Launch Control



Dual-cast, perforated, self-ventilated, 305x28 mm front discs with Brembo fixed 4 piston calipers



Carbon fibre monocoque chassis

COLOUR COMBINATIONS

SPORTS SEATS	Black fabric with red stitching	Black leather with red stitching	Black leather with yellow stitching	Red leather	Tan leather	Leather and microfibre with red stitching	Leather and microfibre with yellow stitching
PASTEL							
Alfa Black	●	○	-	○	○	○	-
Alfa White	○	○	-	○	○	○	-
Alfa Red	○	○	-	○	○	○	-
Giallo Prototipo	-	-	○	-	-	-	○
METALLIC							
Stromboli Grey	○	○	-	○	○	○	-
TRI-COAT METALLIC							
Trofeo White	○	○	-	○	○	○	-
Competizione Red	○	○	-	-	○	○	-

Standard ● Available ○ Not available -



Black fabric with red stitching (standard)

Black leather with red or yellow stitching

Red leather

Tan leather

Leather and microfibre with red or yellow stitching



Alfa Black



Alfa White



Giallo Prototipo



Alfa Red



Stromboli Grey



Trofeo White



Competizione Red

EQUIPMENT

Standard ● Optional ○

EXTERIOR EQUIPMENT	
17" - 18" alloy wheels	●
17" - 18" alloy wheels with dark finish	○
18" - 19" 5-hole alloy wheels	○
18" - 19" 5-hole alloy wheels with dark finish	○
18" - 19" multi-spoke alloy wheels	○
18" - 19" multi-spoke alloy wheels with dark finish	○
Grey brake calipers	●
Black brake calipers	○
Yellow brake calipers	○
Red brake calipers	○
Double chrome exhaust	●
Anodised aluminium skid plate	●
Rear parking sensors (free optional)	○
Carbon fibre windscreen frame	●
Carbon fibre roll bar cover	○
Satin finish wing mirror covers	○
Carbon fibre wing mirror covers	○
Carbon fibre wing mirror covers with Italian flag	○
Front bumper with carbon fibre intake	○
Carbon fibre side air intake	○
LIGHTING SYSTEM	
LED rear lights	●
Bi-Xenon headlights	●
Bi-LED headlights and carbon headlight surround	○
PERFORMANCE	
Double chrome racing exhaust	○
Akrapovič titanium central exhaust system with dual mode	○
Racing suspension (suspension units, front & rear anti-roll bar)	○
AR Racing tyres	○
SAFETY	
Electronic Stability Control with electronic Q2	●
ABS, ASR, CBC, Hill Holder	●
Driver and passenger airbags	●
Tyre Pressure Monitoring System	●
Tyre repair kit	●
Electronic, anti-lifting alarm system with second key	●
PACKS	
	Akrapovič Racing pack
Racing suspension	○
Double chrome racing exhaust	○
Akrapovič titanium central exhaust system with dual mode	○
AR Racing tyres	○
Sports steering wheel in leather with microfibre insert and red stitching*	○
Luxury pack (sports seats in leather or leather and microfibre, Bi-LED headlights and carbon fibre surrounds)	○



17" - 18" alloy wheels (Standard)



17" - 18" alloy wheels with dark finish



Grey brake calipers (Standard)



Red brake calipers



Yellow brake calipers



Black brake calipers



18" - 19" 5-hole alloy wheels



18" - 19" 5-hole alloy wheels with dark finish

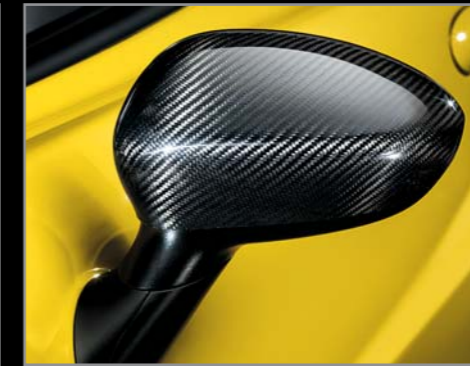

Carbon fibre wing mirror covers



Carbon fibre headlight surrounds



18" - 19" multi-spoke alloy wheels



18" - 19" multi-spoke alloy wheels with dark finish



Double chrome racing exhaust



Akrapovič titanium central exhaust system with dual mode



Carbon fibre side air intake



Carbon fibre roll bar cover

*Content not available when Giallo Prototipo body colour or tan leather are selected.

EQUIPMENT

Standard ● Optional ○

INTERIOR EQUIPMENT	
Height and reach adjustable leather steering wheel	●
Paddle gearshift controls	●
Sports steering wheel in leather with microfibre insert & red stitching*	○
Leather dashboard insert with contrasting stitching	○
Leather insert on dashboard and door panels	○
Carbon fibre air vents	○
Carbon fibre dashboard insert and gearbox panel	○
Sports seats in black fabric with red stitching*	●
Sports seats in black leather with red stitching*	○
Sports seats in black leather with yellow stitching**	○
Sports seats in red leather*	○
Sports seats in tan leather*	○
Sports seats in mixed leather and microfibre fabric with red stitching*	○
Sports seats in mixed leather and microfibre fabric with yellow stitching**	○
Red Interior Kit*** (door pull handle, central tunnel, handbrake grip and boot, steering wheel insert).	○
Adjustable passenger seat	●
Aluminium pedals and footrest	●
Aluminium passenger footrest	●
Carpets kit with embroidered logo	●
Black leather storage pouch	●
Cup holder	●
Smoker's kit	○
ELECTRICAL SYSTEM	
Cruise control (free optional)	○
Remote central locking	●
Electric windows	●
12 Volt socket	●
Alpine radio unit with voice recognition and handsfree functionality	●
Alfa Hi-Fi sound system	●
Alpine Premium Sound System	○
Electric door mirrors	●
Door mirrors with electric defrosting	●
INSTRUMENTATION	
Evolved, 4 position, Alfa D.N.A. driving mode selector	●
Evolved instrumentation with turbo pressure and oil temperature gauges, g-g meter for longitudinal and lateral acceleration	●
Full digital instrument panel with TFT technology	●
Carbon fibre instrument panel fairing	○
Manual air conditioning system	●
ACCESSORIES	
Soft roof stowing bag	●
Red car cover with Alfa Romeo 4C logo	●
Battery charge holder	○
First aid kit	○
Car care kit	●
Fire extinguisher	○
Anti-stone chipping protective film	○



Full digital instrument panel with TFT technology (Standard)



Alpine radio (Standard)



Racing steering wheel



Tan leather seats



Leather door panel



Soft roof stowing bag (Standard)



Black leather storage pouch between seats (Standard)



Carbon fibre gear shift panel



Carbon fibre dashboard insert

* Content not available when Giallo Prototipo body colour or tan leather are selected.

** Content available when Giallo Prototipo body colour is selected.

*** Content available when Sports seats in Red leather are selected.



AR 04C SP





La meccanica delle emozioni

4C
Spider

FREEPHONE NUMBER*

Call ALFA INFOMORE for information on products and services and to request roadside assistance (24 hours a day, 7 days a week).

Alfa InfoMore
00 800 2532 0000

*Remember to check whether your call is free from abroad by contacting your network operator.

WEB

myAlfaRomeo

Take care of your
Alfa Romeo in one click

ALFA ROMEO INFOSOCIAL



Follow #AlfaCare for info from the world of Alfa Romeo or send a public tweet or private message to @AlfaRomeoCareIt for direct help.

E-COMMERCE



Visit the Alfa Romeo
online shop at
www.store.alfaromeo.com