

The new BMW M5



The Ultimate Driving Machine



# THE NEW BMW M5.

ENJOY THE FUN OF DRIVING.



official partner of the  
Olympic and Paralympic Games

# RETURN ON INVESTMENT. IN 4.4 SECONDS.

From a business meeting to the race track and back – this is the new BMW M5. Like its predecessor, this exceptional car embodies discerning understatement and superior performance. Simply press a button and this commanding yet elegant Saloon is transformed into an uncompromising athlete. The new BMW M5 has been created for one purpose – to set new benchmarks.

## THE NEW BMW M5.





## The new BMW M5

### AESTHETICS MEETS ATHLETICS.

- 06 **Interior**  
Exclusive motor sport ambience.
- 08 **Exterior**  
The design language of BMW M.
- 14 **Performance**  
Power, precisely to your taste.
- 18 **Comfort**  
Ahead of its time.
- 20 **Business jet**  
Music palace.

## Technology

### POWER NEEDS EFFICIENCY.

- 22 **Engine**  
Maximum efficiency, maximum performance.
- 24 **Transmission and differential**  
High performance in detail.
- 26 **Chassis and safety**  
From the race track to everyday life.
- 28 **BMW ConnectedDrive**  
The fastest connection to the outside world.

## Equipment

### THE EXCLUSIVE ART OF INDIVIDUALITY.

- 32 **Exterior colours**
- 33 **Upholstery colours**
- 34 **Interior colours and trims**
- 35 **Combination examples**
- 36 **Standard / Optional equipment**

## Overview

### THE NEW BMW M5 AT A GLANCE.

- 37 **BMW Driving Experience**
- 38 **Equipment tables**
- 40 **Technical data**
- 42 **London 2012 Olympic and Paralympic Games**
- 44 **BMW Service and BMW Brand**  
Exclusive offers for BMW customers.

[www.bmw.co.uk/newM5](http://www.bmw.co.uk/newM5)

## Editorial

# TWO WORLDS. ONE STATEMENT.

When the world of cutting-edge motor sports technology meets the world of athletic design, an exceptional form is created: the new BMW M5.

For the fifth generation BMW M5, nothing counts more than the ambition to inspire. From the performance of the 560hp engine, to the finest materials and first-class workmanship, BMW M demonstrates this ambition once more – in a more resounding and confident way than ever before.

The new BMW M5. A car displaying the very best of two worlds.

[www.bmw.co.uk/newM5](http://www.bmw.co.uk/newM5)

#### Equipment of model shown: BMW M5 Saloon

Engine:	M TwinPower Turbo V8 petrol
Output:	560hp (412kW)
Wheels:	20" light alloy M Double-spoke 343 M with mixed tyres
Exterior colour:	Monte Carlo Blue, metallic
Upholstery:	Silverstone Merino leather
Interior trim:	Aluminium Trace

For information on fuel consumption and CO<sub>2</sub> emissions, please refer to pages 40 | 41.



BMW UK on Facebook  
[www.facebook.com/bmwuk](http://www.facebook.com/bmwuk)

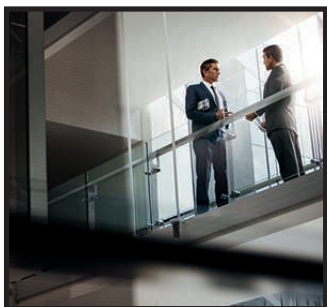

// ONE SALOON.  
ONE SPORTS CAR.  
NO COMPROMISES.

#### MOTOR SPORTS CHARACTER – EXCLUSIVELY REFINED.

A first glance inside the new BMW M5 interior reveals a harmonious relationship between exclusivity and dynamics. Settling into the car, it already looks and feels faster. Perhaps it's the ergonomic arrangement of the M specific controls or the elegance of the Aluminium M

mouldings that accentuate the sporty ambience. Or maybe it's the scent of fine-grained leather covering the M Sport seats. One thing is abundantly clear – the unique combination of luxury and sportiness will elevate your driving experience to another level.



// THE PRESENCE OF INNER STRENGTH.

**THE BUSINESS SALOON THAT SPEAKS THE LANGUAGE OF A SPORTS CAR – FLUENTLY.**

From the financial district to the fairway, the athletic character of the new BMW M5 blends seamlessly with a classic Saloon silhouette to create a stunning exterior. The dynamic front, aerodynamic M exterior mirrors, and typical M shaped integrated side gills form an iconic look that flows through the deep-marked side skirts to the powerful rear. A restrained M shaped rear spoiler and diffuser, together with twin dual tailpipes, complete the look. The expression in the design of the new BMW M5 represents one element above all: Power.



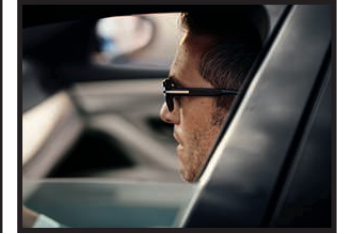

// YOU DON'T HAVE TO PROVE ANYTHING. THE PROOF IS ALL HERE.

---

**THE FRONT OF THE NEW BMW M5 –  
THE EXPRESSION OF A POWERFUL CHARACTER.**

---

Casting your eye at the strong front of the new BMW M5 hints to the potential beneath the exterior. Large air inlets in the distinctive front apron supply the high-performance engine and compound brake system with cooling air. All M specific exterior design features are

based on the technical requirements of the high-performance Saloon. Exclusive M paintwork in Monte Carlo Blue metallic provides distinct accents to emphasise an athletic appearance. Visually, there's no doubt that this car sets its own standards.

// POWERED  
INTELLIGENCE.



// WORK HARD.  
PLAY HARDER.

#### MOTORSPORT GENES – ON CALL.

In the cockpit of the new BMW M5 every detail of the driving experience is precisely aligned for intuitive control – assisting fast and accurate decisions. Two freely configurable M drive settings on the M leather steering wheel let you choose between sports dynamics or long distance comfort at the touch of a button. Change between the M Double Clutch Transmission's seven-

speeds using the M gear shift paddles – for an even sportier driving experience. In addition, the full-colour M specific Head-up Display projects driving and navigation data (including the optimum gear-change point) directly onto the windscreen – creating a safer and more convenient way to navigate the road ahead.



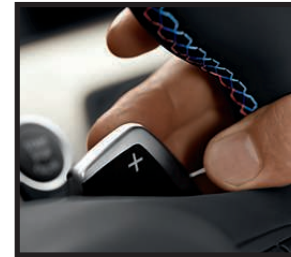

// UNCOMPROMISING POWER.

#### THE MOST IMPRESSIVE FIGURES IN ITS CLASS.

Power on the road has no room for compromise. The eight-cylinder M TwinPower Turbo engine delivers 560hp (412kW)<sup>1</sup> and up to 680Nm of torque, to accelerate the car from 0 to 62mph in just 4.4 seconds. What's truly impressive is its extremely broad rev range and immediate engine response. The linear power release is available from the first touch of the accelerator right through the entire rev range. The seven-speed M Double Clutch Transmission is designed for uninterrupted acceleration completing every gearshift within a fraction of a second, without traction loss.

The M high-performance chassis delivers an assured, responsive and stable drive. With the redeveloped active M differential lock, you enjoy the maximum in traction and control at all times – optimising driving pleasure. The high-performance compound braking system provides maximum safety and precision, even when faced with the most challenging road conditions. Thanks to BMW EfficientDynamics, the new BMW M5 also enhances the relationship between performance and fuel consumption.

<sup>1</sup> For information on fuel consumption and CO<sub>2</sub> emissions, please refer to pages 40 | 41.



// TIME IS A LUXURY.  
ESPECIALLY WITHIN  
THE NEW BMW M5.

---

**ENTER THE DOMAIN OF PERSONAL FREEDOM.**

---

Because time doesn't stand still, the new BMW M5 has been designed to ensure that any journey is time well spent. Exceptional seating comfort and generous space make driving a pleasure and the optional BMW ConnectedDrive technologies

provide comprehensive connectivity when it's time to keep in touch with the outside world. Whether through emails, your address book, GPS technology or internet-based services, you're always connected – from the comfort of your seat.



# BUSINESS JET.



**Read what the BMW M5's Project Manager, Maximilian Ahme, has to say about the fascinating character of this exceptional new Saloon.**

For more than 25 years the BMW M5 has been considered the benchmark Sports Saloon. In what aspects is the fifth generation better than its predecessors?

**Ahme:** Like all BMW M5 cars before it, the fifth generation model is a wolf in sheep's clothing. On one hand, it is a comfortable Saloon, on the other, it is a race car. It has the whole package with its contemporary shape and high level of efficiency.

Which values are behind this apparent contradiction?

Our new M TwinPower Turbo V8 engine has an output of 560hp available between 5,750–7,000 revs and 680Nm of torque. It is one of the rare machines that is able to combine two things: turbo charging and high revs. Nevertheless, it has a remarkably low combined fuel consumption of 28.5mpg<sup>1</sup>, 30% below its predecessor.

Apart from the engine performance, BMW M5 drivers place great importance on precise handling and exceptional traction. What can the new BMW M5 offer here?

A precise and responsive hydraulic steering system in conjunction with powerful rear-wheel drive ensures the driver gets a pure feeling for the road and the forces at the front wheels. A new active M differential lock increases the traction at the rear axle and contributes to greater agility.

The previous rear differential lock system was already highly regarded. In what aspects is the new one better?

The new active M differential lock system is electronically controlled and built for the future. The previous system only activated the differential lock if the rear wheels slipped but we are now able to control the lock system proactively. As soon as the driver accelerates and the sensors anticipate wheel slip the system engages the active M differential lock.



The M specific Head-Up Display shows additional driver information like the optimal gear-change point.

<sup>1</sup> For information on fuel consumption and CO<sub>2</sub> emissions, please refer to pages 40 | 41.

## POWER MEETS EFFICIENCY.

The following data speaks for itself: 680Nm, 560hp (412kW)<sup>1</sup> and 0 to 62mph in 4.4 seconds. The eight-cylinder M TwinPower Turbo engine of the new BMW M5 sets new standards in performance. Enlarged air coolers and the patented TwinScroll turbo charging concept provide a truly exceptional engine response and the torque is available across an

extremely broad rev range. Thanks to VALVETRONIC technology and high-precision direct injection, the engine sets new standards in combining performance and fuel consumption. BMW EfficientDynamics (including the Auto Start-Stop function and Brake Energy Regeneration) means a combined fuel consumption of 28.5mpg is achieved.

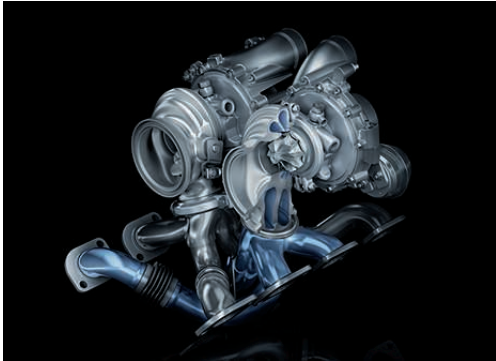

**TwinScroll turbo charging:** Highly efficient and innovative exhaust routing technology combined with super-fast responding TwinScroll turbo chargers lead to minimum turbo lag with immediate power release.

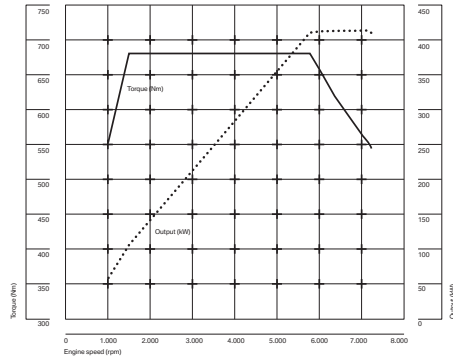

Torque is linked to an extremely broad rev range from 1,500 to 5,750rpm for constantly high engine power and a linear power output.

<sup>1</sup> For information on fuel consumption and CO<sub>2</sub> emissions, please refer to pages 40 | 41.

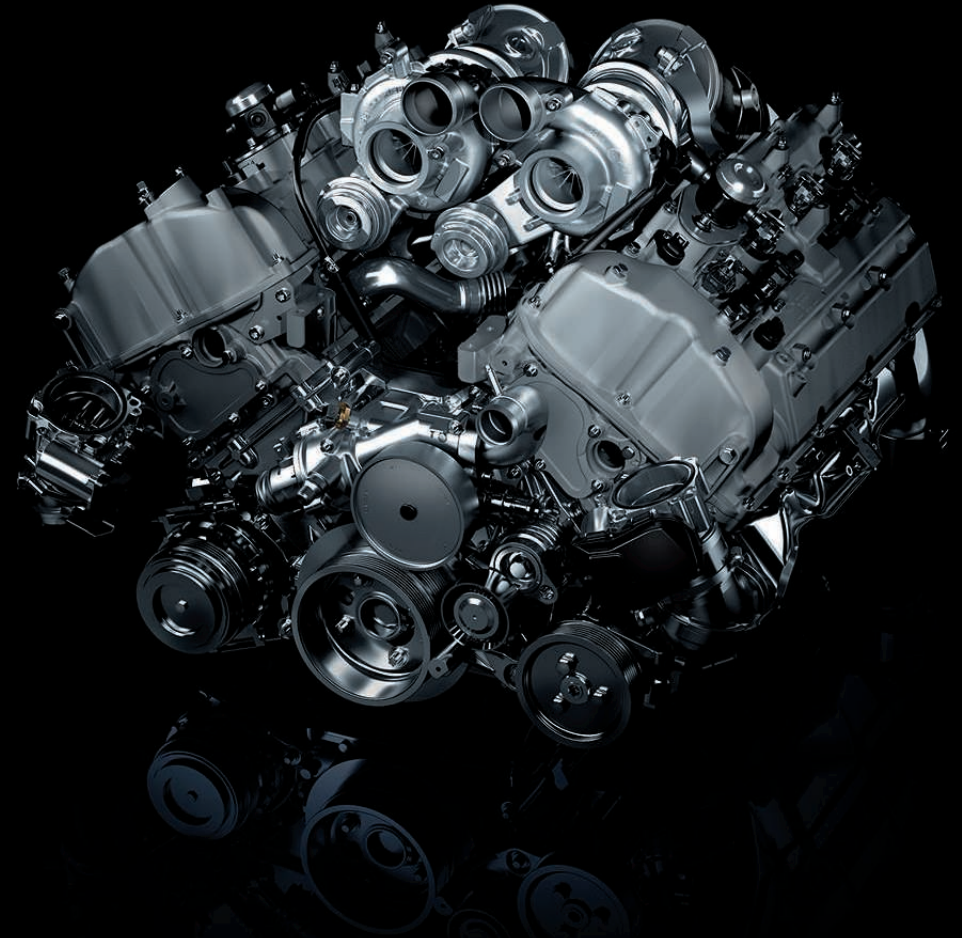

# PERFECTION HAS NO LIMIT.



From comfort-focused to extremely dynamic, the gearshift characteristics of the seven-speed M Double Clutch Transmission in the new BMW M5 can be tailored to suit a range of preferences. In manual mode, M Double Clutch with DRIVELOGIC delivers instantaneous responses because it translates the engine's energy into uninterrupted, remarkable propulsion.

The principle of the M Double Clutch with DRIVELOGIC has its focus on high-revving engines, heralding from motorsport. You shift the forward gears using paddles without taking your hands off the steering wheel. And, as in top-level motorsport, you can change up while keeping your foot on the accelerator – to experience intense acceleration that gives valuable tenths of a second of uninterrupted speed.

Double Clutch with DRIVELOGIC works by using two partial transmissions. One contains gears 2, 4 and 6; the other has gears 1, 3, 5 and 7. When you change gear, it switches from one transmission to the other. This means that while one gear is disengaging, the next is already engaged. As a result, there's no break in the flow of power between shifts, so it's smooth, comfortable and, above all, supremely fast when you change up. To heighten the dynamic driving impressions and further improve the car's acceleration, torque is increased to an even higher degree when shifting

gears by means of appropriately configured DRIVELOGIC programmes. Combined with the close ratio gaps between the gears, these programmes ensure that the driver senses each gearshift as the starting point for an ever-stronger surge of acceleration. The M Double Clutch Transmission employs the same principle on downshifts. However, the transmission's electronics engage gears more smoothly on downshifts to prevent the unwanted effect of the rear wheels being slowed too aggressively.

With DRIVELOGIC, you can adjust the gearshift characteristics to suit your requirements. There is a choice of six drive programmes – three in manual mode and three in automatic. In both cases you can select from a broad spectrum that spans sporting and purist to harmonious and comfortable.

The transmission also provides many additional features, such as Launch Control, which provides the BMW M5 with optimally fast acceleration from a standing start. The M Differential lock on the rear axle helps supply the necessary traction for outstanding acceleration – and guarantees improved dynamic performance even during extremely fast cornering.

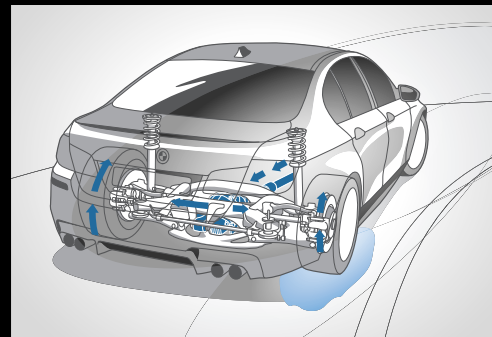

**Active M Differential.** Optimises the traction even during extreme lateral acceleration or on challenging road conditions. The active system is connected with the Dynamic Stability Control via an electronic control unit and provides intelligent use of the locking torque. As a result, it delivers the engine's drive power almost without any loss in acceleration and delivers improved handling and enhanced agility.

## DEVELOPED ON THE RACE TRACK. BUILT FOR EVERYDAY USE.

Conventional rules do not apply for a truly exceptional car like the new BMW M5. As a self-contained development of BMW M, it follows the M philosophy of delivering a perfect balance of performance and efficiency, agility and comfort.

To achieve these high aspirations, the M high-performance chassis was redeveloped from scratch. It owes its perfect tuning to the test drives on the North loop of the Nürburgring – the toughest test environment for M vehicles. The result: maximum driving dynamics and agility combined with maximum precision and control, even in the most testing conditions.

The active M differential lock on the rear axle provides outstanding acceleration, while also delivering enhanced traction during high-speed cornering. Dynamic Damper Control reduces body roll as the shock absorbers automatically adapt to all road conditions according to your preference: Comfort, Normal or Sport. In addition, pre-programmed vehicle configurations can be retrieved via M drive buttons located on the steering wheel. Complementing these configurations is the M dynamic mode, for a truly authentic driving experience. Here, the normal functions of the Dynamic Stability Control (DSC) are reduced so far that stabilizing intervention only occurs in critical situations.



**Compound brake system.** The high-performance brakes in the new BMW M5 provide steadfast stopping power and the utmost stability at all times. The special compound design enables the use of different materials for optimum temperature balance and consistently impressive braking in every situation. Even in the most extreme conditions, the brake system – with its perforated, floating discs – has finely measured, fast reactions and a precise pressure point.

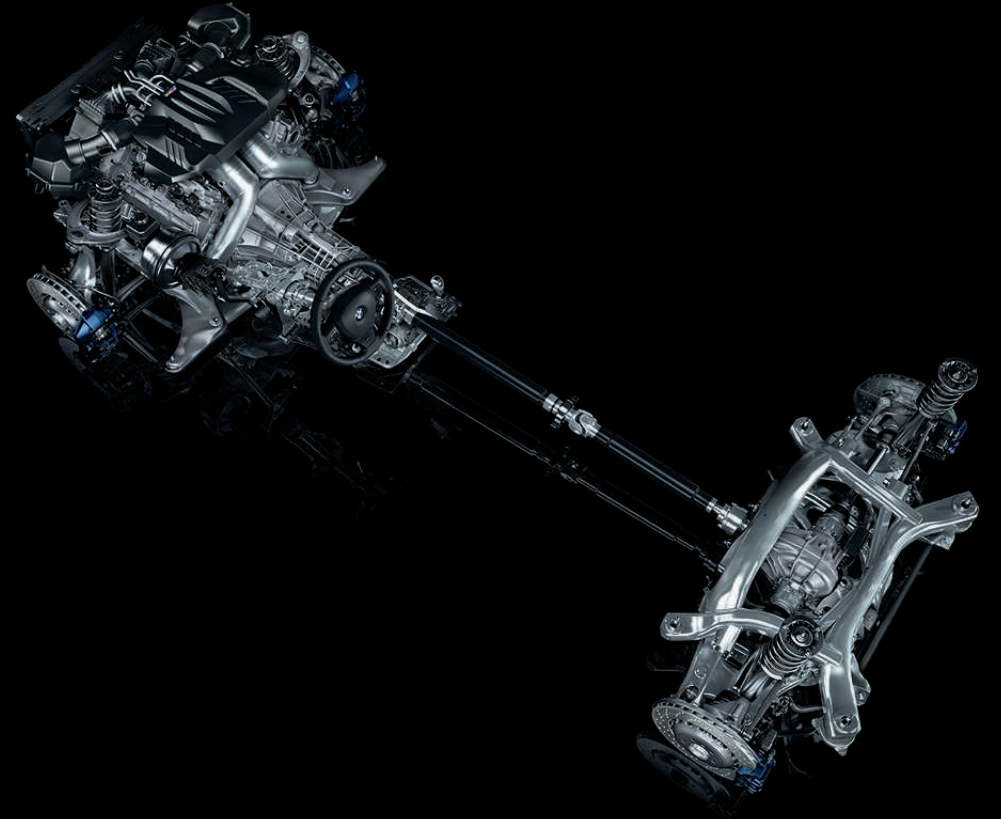

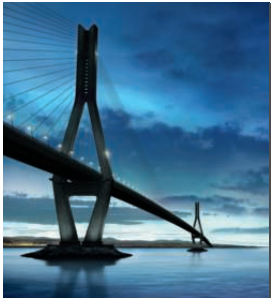

## BMW ConnectedDrive In touch with your world.

Every day, our world is becoming increasingly networked. Many BMW drivers, however, are better connected than most, obtaining information on the road, communicating by phone or email and always updated on the latest events. The term BMW ConnectedDrive encompasses all these services, including traffic features which enable the networking of BMW cars and their occupants with the outside world.



**The next generation of automotive technology.** The BMW Vision ConnectedDrive was developed to demonstrate how BMW ConnectedDrive technologies will continue to pioneer automotive innovations in the future. The concept was consciously designed as a roadster to allow optimal insight into the display and operation of future BMW ConnectedDrive features. Such features include a three-dimensional Head-up Display with Augmented Reality, vehicle-to-vehicle intelligent communication and a new Emotional Browser for sourcing relevant information on the surrounding environment. Three fibre optic light installations flow around the cabin to represent the key BMW ConnectedDrive areas of convenience, infotainment and safety. More information on this concept and future connected mobility projects can be found within our Future Lab.

[www.bmw.com/futurelab](http://www.bmw.com/futurelab)

## BMW CONNECTED DRIVE\*. FOR MORE CONVENIENCE, INFOTAINMENT AND SAFETY.

Wherever the road may take you, you'll always be in touch thanks to BMW ConnectedDrive. Its innovative optional functions ensure optimum networking of driver, vehicle and outside world – any time, any place.

### Convenience.



#### Speed limit display.

Keeps the driver informed of the maximum permissible speed of the road being travelled. A camera 'reads' relevant signs above and beside the road, and compares the information with the speed limits recorded in the navigation system. The speed limit is then displayed in the instrument cluster and the optional Head-up Display.

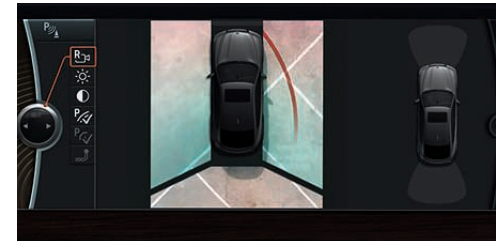

#### Surround-view, side-view and rear-view camera.

Surround-view offers the driver a bird's-eye-view of the area around the vehicle, shown in the Control Display. The rear-view camera provides a view of the area to the rear of the car. In addition, side-view cameras ensure better visibility when joining a main road from a side street or junction.



#### Real-Time Traffic Information (RTTI).

Provides a precise account of current traffic situations in real time. The information is presented on the Navigation map by using a colour coding system indicating the flow of traffic. Road networks are divided into distances as short as 500m for superior accuracy and dependency. Information is automatically updated every 3 minutes allowing the driver to monitor whether the traffic situation is improving or worsening. The system also recommends for or against alternative routes based on the potential time saving benefits.

Certain BMW ConnectedDrive features are optional dependent on the model and options chosen. Screens and services may differ in the UK. BMW Assist services require a connection to a UK mobile telephone network and are not available on the Isle of Man, Channel Islands or in the Republic of Ireland. Some services are available in other European countries; please refer to your local BMW Dealer for more information.

\* Not available in all countries. Please consult your BMW Dealer.

## Infotainment.

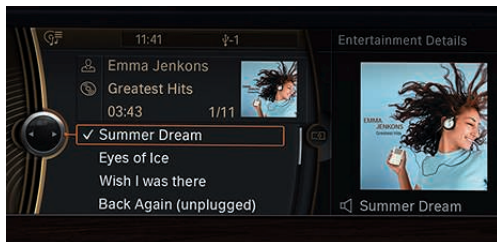

### Bluetooth telephone preparation.

From now on, you can use the time you spend in your car even more effectively. Thanks to the Bluetooth mobile telephone preparation and the intelligent integration of selected compatible business mobile phones<sup>1</sup>, Office functions such as dates, tasks, contacts or SMS messages can be shown on the Control Display, via the Bluetooth connection, or they can be read aloud via the audio speakers, using the narrator function (if the vehicle is also equipped with Voice Control). Thanks to Bluetooth Audio Streaming<sup>2</sup>, wireless playback of music files via selected compatible Bluetooth devices<sup>1</sup> is no problem either.

### Mobile application preparation.

Preparation for iPhone applications are integrated into the vehicle Control Display in combination with a compatible iPhone. With the optional Mobile application preparation feature, users can download the BMW Connected iPhone application free of charge. With this app you're no longer limited to listening to local radio. Using the iDrive system, you can select web radio stations from around the world. You can also call up the latest status reports from your Facebook or Twitter accounts on the Control Display. With this option, audio playback from the iPhone is controlled from the vehicle Control Display using the iPhone user interface.

### USB audio interface.

In conjunction with an optional navigation system, the USB audio interface and an original iPod USB cable, the album cover art for the track being played can be shown on the Control Display in the car (the cover art display function is also available for other devices). The USB audio interface also allows the connectivity software in your BMW to be easily updated, so new compatible mobile phones and music players become fully operational after updating with a USB memory stick.<sup>1</sup>

### Internet.

In-car browsing of the World Wide Web is now available with the optional Internet feature. Websites are displayed in the high resolution vehicle Control Display with the iDrive controller doubling as a mouse for on-screen navigation. The connection operates via the built-in vehicle SIM card and thus no external mobile device is required for operation. All data costs for a three year term are included as part of the optional BMW Assist package. The Internet service is only available when the vehicle is stationary.

<sup>1</sup> For information on compatible devices, see [www.bmw.com/bluetooth](http://www.bmw.com/bluetooth)

<sup>2</sup> A list of music phones enabled for Bluetooth Audio Streaming is available at [www.bmw.com/bluetooth](http://www.bmw.com/bluetooth)

## Safety.



### Head-up Display.

A full-colour TFT display projects important driving information onto the windscreen, in your direct field of vision. Information display includes such things as the current road speed, or navigation instructions. The availability of more colours makes it easier to distinguish general driving information and warnings. The display ensures that your eyes are always on the road ahead, making driving safer.

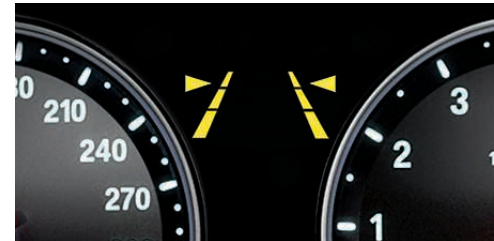

### Lane departure warning and Lane change warning.

At speeds above around 40mph, the Lane departure warning system registers lane markings ahead, up to a distance of 50 metres. If the vehicle deviates from the lane of travel without the use of indicators the steering wheel vibrates as an alert. The lane change warning system warns the driver by means of a visual signal integrated into the exterior mirror if there is a vehicle located in the driver's blind spot or approaching fast from behind.



### High-beam Assistant.

No unintentional dazzle – the optional High-beam Assistant uses an image sensor to recognise oncoming traffic and changing light conditions. When the system is active it automatically switches the high beam on and off.

## Exterior colours.

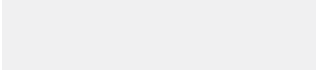

■ 300 Alpine White, non-metallic



■ 475 Black Sapphire, metallic



■ A17 Havanna, metallic

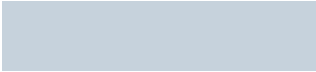

■ A29 Silverstone, metallic



■ A52 Space Grey, metallic



■ A89 Imperial Blue, xirallic



■ B05 Monte Carlo Blue, metallic



■ B41 Singapore Grey, metallic



BMW Individual



□ BMW Individual X02 Citrine Black, metallic



□ BMW Individual S34 Azurite Black, metallic

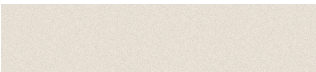

□ BMW Individual X04 Moonstone, metallic



□ BMW Individual X07 Amazonite Silver, metallic



□ BMW Individual X08 Champagne Quartz, metallic

The following pages show the colours and materials available for the new BMW M5. Use them to identify your favourite colours, or compare various combinations. These colour samples are meant to give you a first impression of paints and materials. Experience has shown, however, that printed versions of paint and upholstery colours cannot in all cases faithfully reproduce the appearance of the originals. We therefore recommend that you consult your BMW Dealer on your preferred colour choices. They will be happy to show you samples and assist you with any special requests.

## Upholstery colours.



■ **LKSW Black**, Extended Merino leather<sup>1</sup>



■ **LKA9 Silverstone**, Extended Merino leather<sup>1</sup>



■ **LKDA Sakhir Orange**, Extended Merino leather<sup>1</sup>



□ **X3SW Black**, Full Merino leather<sup>2</sup>



□ **X3A9 Silverstone**, Full Merino leather<sup>2</sup>



□ **X3DA Sakhir Orange**, Full Merino leather<sup>2</sup>



BMW Individual

□ **BMW Individual Extended Merino leather<sup>3</sup>**  
ZAC8 Platinum

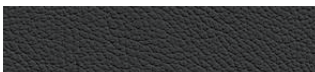

□ **BMW Individual Extended Merino leather<sup>3</sup>**  
ZAP8 Graphite



□ **BMW Individual Extended Merino leather<sup>3</sup>**  
ZAP7 Silk Grey



□ **BMW Individual Extended Merino leather<sup>3</sup>**  
ZAC8 Platinum



□ **BMW Individual Extended Merino leather<sup>3</sup>**  
ZAP6 Champagne



□ **BMW Individual Extended Merino leather<sup>3</sup>**  
ZAWT Cohiba Brown

Please note that over time even normal use can lead to unrecoverable upholstery damage. This can be caused in particular by non-colourfast clothing.

<sup>1</sup> Extended Merino leather includes front and rear seats with headrest, inserts in door trims, centre console including armrest and door armrests.

<sup>2</sup> Full Merino leather includes front and rear seats with headrests, rear of front seats, door trim including armrest, centre console including armrest, instrument panel (top and bottom sections).

<sup>3</sup> BMW Individual Extended Merino leather includes front and rear seats with headrests, inserts in door trims, centre console, armrests and the lower section of the instrument panel.

## Interior colours.



Black

## BMW Individual headlining.



BMW Individual

 **Headlining**  
775 Anthracite

 **BMW Individual Alcantara headlining<sup>1</sup>**  
XD5 Silk Grey

 **BMW Individual Alcantara headlining<sup>1</sup>**  
XD5 Platinum

 **BMW Individual Alcantara headlining<sup>1</sup>**  
XD5 Champagne

 **Headlining**  
776 Anthracite Alcantara

## Interior trims.

 **4L9 Aluminium Trace**

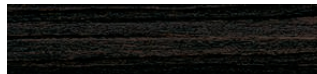
 **4BN Dark Ash Grain wood, High-gloss**

 **4CE Finline Anthracite wood, High-gloss**































BMW Individual

 **BMW Individual Interior trim**  
XE5 Auburn Sycamore wood, High-gloss

 **BMW Individual Interior trim**  
XE6 Honey Brown Satin Walnut wood, High-gloss

 **BMW Individual Interior trim**  
XE7 Piano Black, High-gloss

# Combinations.

Upholstery material	BMW upholstery colours						BMW Individual upholstery colours				
	Extended Merino leather <sup>2</sup>			Full Merino leather <sup>3</sup>			BMW Individual Extended Merino leather <sup>4</sup>				
	Black	Silverstone	Sakhir Orange	Black	Silverstone	Sakhir Orange	Graphite	Silk Grey	Platinum	Champagne	Cohiba Brown
Sport seats	•	•	•	•	•	•	•	•	•	•	•
<b>Upholstery colours</b>											
<b>Interior colours</b>	Black	Black	Black	Black	Black	Black	Black	Black	Black	Black	Black
<b>BMW exterior colours</b>											
300 Alpine White, non-metallic		•	•	•	•	•	•	•	•	•	•
475 Black Sapphire, metallic		•	•	•	•	•	•	•	•	•	•
A17 Havanna, metallic		•	•	•	•	•	•	•	•	•	•
A29 Silverstone, metallic		•	•	•	•	•	•	•	•	•	•
A52 Space Grey, metallic		•	•	•	•	•	•	•	•	•	•
A69 Imperial Blue, xirallic		•	•	•	•	•	•	•	•	•	•
B05 Monte Carlo Blue, metallic		•	•	•	•	•	•	•	•	•	•
B41 Singapore Grey, metallic		•	•	•	•	•	•	•	•	•	•
<b>BMW Individual exterior colours</b>											
X02 Citrine Black, metallic		•	•	•	•	•	•	•	•	•	•
S34 Azurite Black, metallic		•	•	•	•	•	•	•	•	•	•
X04 Moonstone, metallic		•	•	•	•	•	•	•	•	•	•
X07 Amazonite Silver, metallic		•	•	•	•	•	•	•	•	•	•
X08 Champagne Quartz, metallic		•	•	•	•	•	•	•	•	•	•
<b>BMW interior trims</b>											
4L9 Aluminium Trace		•	•	•	•	•	•	•	•	•	•
4B8 Dark Ash Grain wood, High-gloss		•	•	•	•	•	•	•	•	•	•
4CE Finesline Anthracite wood, High-gloss		•	•	•	•	•	•	•	•	•	•
<b>BMW Individual interior trims</b>											
XE5 Auburn Sycamore wood, High-gloss		•	•	•	•	•	•	•	•	•	•
XE6 Honey Brown Satin Walnut wood, High-gloss		•	•	•	•	•	•	•	•	•	•
XE7 Piano Black, High-gloss		•	•	•	•	•	•	•	•	•	•

<sup>1</sup> Only in combination with Individual upholstery.

<sup>2</sup> Extended Merino leather includes front and rear seats with headrest, inserts in door trims, centre console including armrest and door armrests.

<sup>3</sup> Full Merino leather includes front and rear seats with headrests, rear of front seats, door trim including armrest, centre console including armrest, instrument panel (top and bottom sections).

<sup>4</sup> BMW Individual Extended Merino leather includes front and rear seats with headrests, inserts in door trims, centre console, armrests and the lower section of the instrument panel.

## Standard / Optional equipment.



■ **Shortened gear lever** for seven-speed M Double Clutch transmission with DRIVELOGIC. Sporty, shortened design with M logo, illuminated.



■ **M Sport seats** for driver and front passenger with M-specific seam, extra-contoured seat and backrest sides, electric backrest, length and height adjustment. Also feature manually adjustable thigh support, including angle adjustment and memory function for driver.

□ **4MA M Sport multi-function seats, front** with driver memory, M embossing on the headrests. Includes **488 Lumbar support** for driver and front passenger, giving pneumatic height and depth adjustment to the lower backrest, for an ergonomically perfect seat position and support of back muscles.



■ **Door sill finishers** with aluminium inserts and M5 designation make a powerful statement the moment you get in.



■ **Instrument panel** with permanently illuminated white surrounds for speedometer and rev counter as well as fuel level and oil temperature displays.



■ **19" light alloy M Double-spoke style 345M** with mixed tyres, front 9 J x 19, 265/40 R19 tyres, rear 10 J x 19, 295/35 R19 tyres.

## Driver training.

Owning a BMW is something quite special. Controlling and fully savouring its dynamics enriches the experience many times over – and there's nowhere better to do this than on a race track. The BMW Driving Experience offers an exclusive opportunity to live out this passion on world-class circuits such as the Nürburgring, the Salzburgring and Hockenheim.

Immerse yourself in the fascinating world of high-performance motorsport. Develop a feel for high speed and learn how to handle extreme situations with skill. From controlled drifts, masterful evasive and overtaking manoeuvres through to perfecting the ideal line, under the professional guidance of BMW instructors you can test your limits and fine-tune your vehicle control to the smallest detail. Only the combination of technical know-how and authentic feel for the road can turn dry driving theory into pure driving pleasure.

Information on training, locations and booking options can be found online at [www.bmw-drivingexperience.com](http://www.bmw-drivingexperience.com). Not available in all countries.



M5 Saloon	
<b>Engine</b>	Catalytic converter
	Digital Motor Electronics (DME)
	EUS emissions management
<b>Transmission</b>	Light aluminium engine block and cylinder head
	M Double-VANOS
	Twin-scroll twin turbochargers
	V8 engine with four-valve technology and high precision injection
	Seven-speed M Double Clutch Transmission (M DCT) with DRIVELOGIC
<b>Wheels and chassis</b>	Active M Differential
	19" light alloy M Double-spoke style 345M
	Brake callipers – Aluminium, front and rear (coloured blue)
	Brake-pad wear indicator
	Compound disc brakes – front and rear, ventilated
	Double-wishbone suspension, front
	Electric Power Steering (EPS) with M Servotronic steering
	Electro-mechanical parking brake
	Integral rear axle
	M Mobility tyre sealing system
	Variable Damper Control (VDC)
<b>Safety and technology</b>	Adaptive Headlights
	Airbags comprising:
	– Advanced Head Protection System (AHPS II), front and rear
	– Crash sensor activating central locking release, hazard warning lights, fuel cut-off, interior lighting and safety battery terminal
	– Driver, front passenger, front and side
	– Impact-dependent airbag system (ID airbags), driver and front passenger
	– Passenger seat airbag deactivation, front
	– Passenger seat occupancy sensor, front
	Alarm system (Thatcham 1) with remote control and engine immobiliser
	Check control warning system
	Child locking system, rear doors
	Condition Based Servicing (CBS)
	Cruise control with brake and speed limiting function
	Deformation zones – front and rear, that can absorb impacts of up to 9.5 mph. Bumpers absorb impacts up to 2.5 mph without damage
	Dynamic Brake Lights
	Dynamic Stability Control Plus (DSC+) comprising:
	– Anti-lock Braking System (ABS)
	– Automatic Stability Control (ASC)
	– Brake drying
	– Brake fade compensation
	– Brake pre-tensioning
	– Cornering Brake Control (CBC)
	– Dynamic Brake Control (DBC)
	– Electronic Brake-force Distribution (EBD)
	– Hill-start assistant
	– M Dynamic Mode (MDM)
	Euro NCAP rating 5
	First Aid kit and warning triangle
	Foglights, rear
	Head restraints – front, anti-whiplash
	Head-up Display
	Headlight wash
	Keyless starting of engine ignition
Locking wheel bolts	
MDrive Manager	
On-Board Diagnosis (OBD)	
Park Distance Control (PDC), front and rear	
Rain sensor with automatic headlight activation	
Seat belts – front, inertia reel with pyrotechnical belt latch tensioner, driver belt force limiter and belt restrainer	
Seat belts – rear, three with inertia reel	
Side impact protection	
Tyre pressure monitoring	
Windscreen washer jets, heated	
Xenon headlights	
<b>Seats</b>	Child seat ISOFIX attachment, two in rear
	Extended Merino leather upholstery
	Seat heating, front
	Sport seats – front, electric with driver memory



<b>Weight</b>		<b>M5</b>
Unladen weight EU <sup>1</sup>	kg	1945
Max. permissible	kg	2410
Max. load	kg	540
Permitted axle load, front/rear	kg	1180/1260
Permitted roof load	kg	100

<b>Engine<sup>3,4</sup></b>		<b>M5</b>
Cylinders/valves		8/4
Capacity	cm <sup>3</sup>	4395
Stroke/bore	mm	88.3/89
Output/engine speed	hp (kW)/rpm	560 (412)/5750-7000
Max torque/speed	Nm/l/min	680/1500-5750
Compression ratio	:1	10

<b>Performance</b>		<b>M5</b>
Top speed	mph (km/h)	155 (250) <sup>F</sup>
Acceleration 0-62mph	s	4.4
Acceleration 0-1000m	s	21.9
Acceleration 50-75mph 4/5 gear	s	3.7/4.6

<b>Fuel consumption<sup>3,4</sup></b>		<b>M5</b>
Urban	mpg (l/100 km)	20.2 (14.0)
Extra urban	mpg (l/100 km)	37.2 (7.6)
Combined	mpg (l/100 km)	28.5 (9.9)
CO <sub>2</sub> emissions	g/km	232
Tank capacity, approx	l	80

<b>Wheels</b>		<b>M5</b>
Tyre dimensions front/rear		265/40 ZR19 / 295/35 ZR19
Wheel dimensions front/rear		9J x 19 / 10J x 19
Material		Light alloy

<b>Electrical system</b>		<b>M5</b>
Battery capacity	Ah	105
Alternator output	AW	209/2926

--	--	--

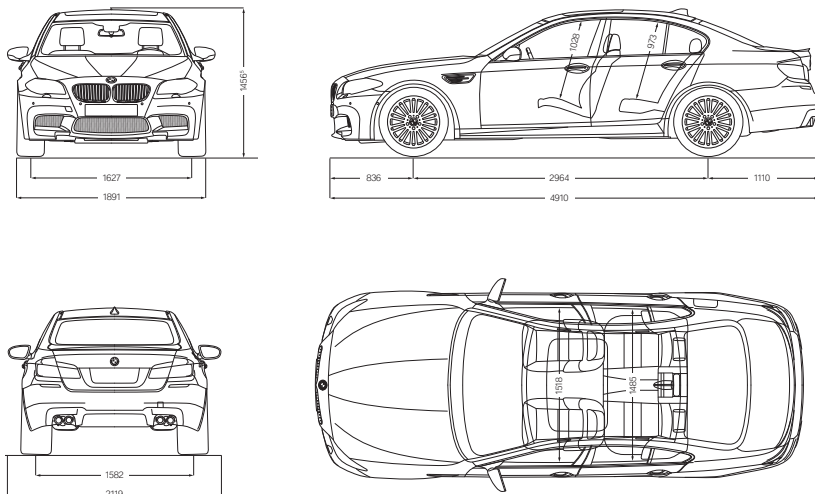

All dimensions of the technical drawings in millimetres. Luggage compartment capacity 520 litres.

<sup>1</sup> Figures quoted include a 90% tank filling, 68kg for the driver and 7kg for luggage. Unladen weight applies to vehicles with standard specification. Optional equipment may increase these figures.

<sup>2</sup> Electronically limited.

<sup>3</sup> The petrol engine is designed for RON 98 fuel or higher. It may be run on RON 91 fuel with a decrease in power.

<sup>4</sup> The petrol engine complies with the EU5 emissions standard. Fuel consumption is determined in accordance with the ECE driving cycle. This is made up of approximately one third urban and two thirds extra-urban driving (based on the distance covered). CO<sub>2</sub> emissions are measured in addition to fuel consumption. Fuel consumption figures are based on vehicles with standard equipment. Fuel consumption and CO<sub>2</sub> emission levels depend on selected wheel and tyre sizes.

<sup>5</sup> 1467 including Shark-fin aerial.

# AN INTRODUCTION TO LONDON 2012.

## Why we were selected as the Official Automotive Partner for London 2012.

Our partnership with London 2012 is a natural fit for the business. Our emission lowering technologies, through the EfficientDynamics programme, will play a role in aiming to deliver the most sustainable Games possible. Our range of the world's most fuel efficient premium cars will transport the Olympic Family at the Games – including athletes, officials and the media – and shine a light on the future of mobility with our ground-breaking developments in the next generation of transportation.

## The Games time fleet.

BMW Group's role is incredibly important to the success of the Games. The fleet that will mobilise the Olympic and Paralympic Games will be over 4,000 vehicles strong. A huge undertaking and commitment. Conventional and hybrid vehicles from the range will be used in the vast Olympic Games fleet and BMW Group will showcase electric vehicles as part of our role in London 2012.

## We're proud to be a partner.

As a major investor and employer in the UK, our partnership will be an inspiration for our customers, employees and dealers, as we continue to develop market-leading innovations and technologies to shape the future of design, development and driving pleasure.

We are immensely proud of our partnership.

## BMW London 2012 Performance Team.

BMW is proud to support Team GB and ParalympicsGB athletes through the BMW London 2012 Performance Team. We want to help the athletes qualify and succeed at the Games. Behind our intelligent technologies lies an understanding that even the smallest change can make a big difference to performance – something that every athlete knows. We'll be working with our London 2012 hopefuls to see how we can actively support them through our world-leading technical expertise. It's going to be an amazing journey.



# MEET THE BMW LONDON 2012 PERFORMANCE TEAM.



## MARTYN BERNARD High Jump

My parents got me into athletics as a way of channelling my energy, and I haven't looked back. I won my first major medal in 2005 and am now focusing on London 2012, along with studying for my Law degree.



## MARK HUNTER Rowing

I think the turning point in my career was moving to the prestigious Leander Club, which gave me the opportunity to row with the best athletes in the world. I strive to keep improving and, having already won gold in Beijing 2008, a win in London 2012 would be extra special.



## ALISTAIR BROWNLEE Triathlon

I still remember the thrill of being told I could win medals by my local swimming club. The joy of being outdoors and active led me to my first triathlon when I was 10, and winning the World Junior Championships in 2006 drove me to pursue my Olympic dream. Hopefully I'm on track for London 2012.

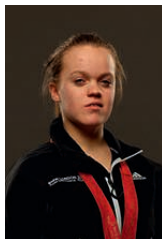

## ELLIE SIMMONDS Paralympic Swimming

I was inspired to take up competitive swimming by the Athens Paralympic Games in 2004. After winning two gold medals in Beijing 2008, I became the youngest person to be awarded an MBE, aged 14. Since then, I've been working hard towards London 2012.



## JONATHAN BROWNLEE Triathlon

I started swimming at 4, but when I was 10 my Uncle was in a local triathlon and I couldn't wait to try it too. A month later I took part in my first event. That summer I watched Cathy Freeman race to victory in Sydney 2000 – and I can still remember every second.



## LOUIS SMITH Gymnastics

My first Olympic Games was Beijing 2008, where I won the bronze for the men's pommel horse. That made me the first Briton to win a medal in the individual gymnastics since 1908. Since then I've picked up medals in 2009 and 2010. So hopefully I'm on track for London 2012.



## TOM DALEY Diving

I started diving by chance when I was 7, and began competing just before my 9th birthday. There have been lots of highlights since then, including winning the World Championships when I was 15 and picking up two gold medals at the 2010 Commonwealth Games Delhi.



## TOM AGGAR Paralympic Rowing

I started rowing after an accident in 2006 and won my first event at the British indoor championships that year. In 2007 I won gold in a world best time at the World Championships in Munich and I have recently won the International Rowing Federation's first 'Paralympic Rower of the Year' award – my next goal is gold at London 2012.

**BMW LONDON 2012**  
PERFORMANCE TEAM

More athletes are coming soon. You can follow their journey at [bmw.co.uk/london2012](http://bmw.co.uk/london2012)



official partner of the  
Olympic and Paralympic Games

**Condition Based Service.** A key feature in most BMW models, Condition Based Service (CBS) signals an innovative leap forward in BMW Service diagnostic technology. The way it works is simple. CBS uses sensors to constantly monitor the areas of your BMW that are subjected to wear and tear. Based on the results of the data, CBS decides the extent to which servicing is necessary. This information is then stored in your vehicle's key. Using a KeyReader, BMW Service staff can download information to provide an accurate analysis of your vehicle. This means your BMW goes for a service only when it needs to, saving you an immeasurable amount of both time and money.

**Service Intelligence.** BMW Approved Technicians are experts in the use of diagnostic equipment, which quickly identifies if and why the vehicle is running at anything less than peak efficiency. This leads to rapid identification and rectification.

**Service Assurance.** For additional peace of mind, take comfort in the fact that every new BMW is covered by a three-year warranty<sup>3</sup> that includes BMW Emergency Service throughout Europe. For more information on BMW Service, please contact your local BMW Dealer, BMW Service Authorised Workshop or visit [www.bmw.co.uk/service](http://www.bmw.co.uk/service) or [www.bmw.ie](http://www.bmw.ie).

## JOY IS BMW SERVICE.



**BMW Service Inclusive.** Wouldn't it be good to know all your servicing costs in advance? Well, that's exactly what BMW Service Inclusive<sup>1</sup> provides and for a low one-off payment.

BMW Service Inclusive<sup>1</sup> lasts for 5 years or 60,000 miles (whichever occurs first) and covers all your vehicle's servicing requirements. Alternatively you can choose BMW Service Inclusive<sup>1</sup> Plus, which in addition to servicing also covers maintenance items such as brake pads, brake discs and windscreen wipers. And whenever servicing and maintenance work is carried out on your BMW, you can be sure that it will only be done by fully qualified BMW Service Approved Technicians at one of over 150 BMW Service Authorised Workshops around the country. Furthermore, only Genuine BMW Parts are used – each covered by a two year warranty.

BMW Service Inclusive and Service Inclusive Plus are transferable to subsequent owners within the time and mileage period, which can enhance the resale value of your car.<sup>2</sup>

<sup>1</sup> Service Inclusive and Service Inclusive Plus are available as cost options. Terms and conditions apply, for full details speak to your Dealer or visit [www.bmw.co.uk/serviceinclusive](http://www.bmw.co.uk/serviceinclusive)

<sup>2</sup> For further information, please contact your local BMW Dealer.

<sup>3</sup> Every new BMW registered within the Republic of Ireland is covered by a two-year manufacturer's warranty – for details, please contact your local BMW Dealer.



**BMW Assist.** BMW Assist provides telematic and online services that are fully integrated with the BMW navigation and Bluetooth telephone systems to offer enhanced services. This provides you and your passengers access to key information from within the vehicle, helping you keep safe and in touch. In the event of an emergency, a 999 SOS call can be triggered manually or in extreme situations automatically. Details of your vehicle and location will be sent directly to a 999 SOS Emergency Service centre so help can be sent without delay. A similar function is also available to connect you to a BMW Service Centre should you require roadside assistance. If you have locked your keys in your car, or cannot recall if you have locked your car, with Remote Services the BMW Service Centre can lock or unlock your vehicle remotely.

Information-based services are also included, you can make an Information Plus call to request addresses and

telephone numbers are transferred to your vehicle. There is also the facility to send addresses and telephone numbers directly to your vehicle yourself with Google Maps. Using the in-car portal on your vehicle's Control Display you can check the latest news and weather, or access the Google Local Search from where you can look-up business addresses in the car yourself. For vehicles with the BMW Professional Multimedia Navigation system, the Routes service provides a route planning facility from the comfort of home, or access to download a variety of predefined BMW Routes across Europe.

BMW Assist services are free of charge for three years on any new BMW M5 equipped with a navigation system. Services are not available in the Republic of Ireland, Isle of Man and the Channel Islands. Some services are available in other European countries. Terms and conditions apply.

## SHAPING THE FUTURE – RESPONSIBLY.

The BMW Group has been ranked the most sustainable automotive company worldwide in the Dow Jones Sustainability Index for the sixth time in a row. Sustainability is an integral part of our value chain – it encompasses every stage from the development of fuel-saving and alternative vehicle concepts to environmentally-friendly production processes and recycling. Our research and development philosophy BMW EfficientDynamics delivers tangible benefits to customers, our climate and the environment. This is reflected in the reduction of CO<sub>2</sub> emissions by nearly 30% across our European fleet of new cars since 1995.



## JOY COMES IN MANY FORMS.



**BMW Emergency Service.** BMW Emergency Service is the only roadside and assistance programme designed specifically for BMW vehicles offering an exceptional range of benefits and services. It is available 24 hours a day, 7 days a week and utilises a dedicated fleet of BMW Approved Technicians, equipped with Genuine Parts and tools, ensuring that you and your vehicle receive the best possible care in the event of any motoring emergency. This tailor-made programme has been specifically designed to meet the needs of BMW drivers travelling in the UK, Republic of Ireland and Continental Europe giving complete reassurance and peace of mind. Every new BMW is covered for three years.



**BMW Financial Services.** Chances are you've already decided on the BMW you want to drive. Now discover the perfect finance solution to get you behind the wheel. BMW Financial Services offers a range of tailor-made finance and insurance packages designed to suit you and your budget. And if you opt for insurance from BMW Financial Services, you'll be prepared for all eventualities. For more information, contact your local BMW Dealer. Alternatively visit [www.bmwfs.co.uk](http://www.bmwfs.co.uk) or call us on 0870 5050 150.

Our comprehensive range of finance and insurance products includes:

- BMW Select (Personal Contract Purchase)
- BMW Hire Purchase
- BMW Contract Hire
- BMW Leasing
- BMW Car Insurance
- BMW Income Protection
- BMW Shortfall



**BMW Magazine.** Every new BMW customer receives a complimentary subscription to BMW Magazine. This publication features all the latest news and developments from BMW, together with a variety of driving and lifestyle features.

**BMW News.** To ensure you're one of the first to hear the latest BMW news and developments, BMW UK offer an email programme.

Sign-up at:  
[www.bmw.co.uk/newsletter](http://www.bmw.co.uk/newsletter)



**BMW World, an iconic building in the Munich skyline.** The BMW World is a true brand experience where it's possible to marvel at the historic BMWs in the museum, learn about our engineers' newest innovations and take a tour of the plant to experience with your own eyes the cutting-edge and exacting methods used to create a BMW.

Car manufacturing requires a great deal of water, which is why we've developed an intelligent circulatory system for our factories that ensures water is re-used as often as possible. The dream of a manufacturing process that does not produce any waste water has already been made a reality at our engine plant in Steyr. In 2008, 733,500 engines were manufactured without producing a single drop of waste water.

Sustainability is taken very seriously at the BMW Group. For this reason, we prioritise environmentally-friendly methods of transport such as rail and shipping and work towards capacity optimisation. Each year, we cover around 15.8 billion tonne kilometres transporting materials and new vehicles. Of this, 79% of the total transported volume is delivered by sea – which benefits both road traffic and the environment.

The BMW Group has their sights set on tomorrow. Your BMW is part of a comprehensive recycling concept. Every single vehicle can be easily and economically recycled. Please contact your BMW Dealer on all matters regarding the return of your end-of-life vehicle. For more information visit:

- [www.bmw.co.uk/EfficientDynamics](http://www.bmw.co.uk/EfficientDynamics)
- [www.bmwgroup.com/sustainability](http://www.bmwgroup.com/sustainability)

More about BMW



The Ultimate Driving Machine

[www.bmw.co.uk](http://www.bmw.co.uk)



The models, equipment and possible vehicle configurations (standard and optional equipment) illustrated in this Brochure reflect the specifications of vehicles supplied by BMW AG to the German market. In other EU member states, individual models' equipment content and possible configurations of standard and optional equipment may vary. For precise information on the various country-specific versions available, please contact your local BMW Dealer. Subject to change in design and equipment. Part number 94 23 2 111 099.  
© BMW AG, Munich/Germany. Not to be reproduced wholly or in part without written permission of BMW AG, Munich.

BMW recommends **EDGE**