



CITROËN ^ VISA

## A serious call to those who are ahead of the Joneses

Do you sincerely want freedom of choice?  
Individuality in what you've chosen?

Comfort normally found only in luxury cars.

Unique new technology in an economic yet truly spacious car, which is more manoeuvrable and easier to park than many of its smaller rivals?  
Versatility with capacity for every use you envisage for your car?

Built in 'extras' including rear wash/wipe, reversing lamps and internally adjustable headlamps.  
Proven engineering so there's no gremlins to foul up reliability.

Front wheel drive acclaimed for road holding in any weather, scores smugly in winter when other cars dig their own graves with their rear wheel drives.

You should seriously consider matching your personality to the variety offered in the new Citroën Visa 5-door hatchback, which you can buy for the price of other manufacturers' 3-door models.

These are your options:

Visa Club with a twin cylinder air-cooled engine capable of 50 mpg with ease. That means well over 400 miles on a full tank, reassuring these days when petrol shortages seem to spring up over night. Top speed 77 mph.

Visa Super with a 4 cylinder overhead camshaft, water-cooled engine, quick off the mark but well able to achieve over 40 mpg. Top speed 90 mph. In addition, the VISA SUPER has protective side mouldings, halogen headlamps, a more luxurious interior and, to stiffen the suspension to cope with faster driving, a rear anti-roll bar (Visa Club has front anti-roll bar only).





The Citroën Visa has been designed as a spirited motor car to take its place in the Citroën range between the long running 2CV-Dyane group and the GS series.

The brief for the designers was to produce a car that would be:  
Versatile and individual  
Spacious yet compact  
Handy in town and country  
Economic, with outstanding performance

The result, the Citroën Visa, in its Club and Super versions is a stylish modern vehicle of exceptional economy with appeal as a family car, convenience as a second car, or as a utility workhorse; a car of personality with a capacity for controlled performance presenting an image of either dignity or impudence to reflect the character of its driver; exploiting advanced technology but retaining mechanical reliability.

**Versatile:** up-market in the Mall, utility in the Malvern Hills

**Spacious:** enough leg, hip, elbow shoulder and head room even for lanky 6-foot drivers and their passengers

**Compact:** just over 12 ft long with a tight 31 ft turning circle and rewarding acceleration; scampers through traffic and parks like a dream

**Handy and economical:** a group of journalists on a pre-launch test drive recorded an overall average consumption of 52 mpg for the Club and 41 mpg for the Super, without, on their own admission, 'trying hard'.

**Revolutionary, yet reliable:** The IEI (Integrated Electronic Ignition) fitted to the Club has never been installed before in a mass produced car, yet Citroën advanced product laboratories have long been working to perfect the technology and Citroën engineers have been able to take advantage of the Peugeot-Citroën Group's engineering developments which have already proved successful. The Visa's innovations are, therefore, long tested research successes and long-term reliability has been assured without making guinea-pig victims of the public.



## What's new in the Citroën Visa?

**Engines:** The Visa Club is fitted with a new Citroën flat-twin air cooled engine and a modified gearbox of the type designed for the heavier and faster Citroën GS. Consequently the gearbox never gets close to its stress limits, so giving outstanding reliability and exceedingly long life. New features in the light-alloy 652cc engine, which develops 36 bhp at 5,500 rpm, include: the crankshaft, of steel alloy, retained by three bearings to reduce vibrations (and therefore noise). Connecting rods are cast in one piece. The cylinders are of aluminium with a special inner coating, using a process perfected during Citroën's development of rotary piston engines. The centrally located camshaft has a new profile specially designed for improved torque at low revs; the maximum DIN torque is 38.3 ft-lb at 3,500 rpm. The gearbox, set behind the engine in line with it, is mechanically controlled with a floor-level lever, and has four synchromesh forward gears.

The Visa Super is fitted with a 4-in-line cylinder water-cooled 1124cc engine. A very compact, up to date engine relying mainly on light alloys, it has an overhead camshaft and develops 57 bhp at 6250 rpm; maximum DIN torque is 59.3 ft-lb at 3000 rpm. The gearbox is built in with the engine and both have a common lubrication circuit. The gearbox is mechanically controlled by a floor-level lever and has four forward synchromesh speeds.

**Ignition:** IEI, Integrated Electronic Ignition, installed in the Visa Club model gives ultra-accurate computerized timing to the spark and supports it with a constant high voltage. It gives the engine the highest possible efficiency – by

maintaining an optimum state of tune – with minimum fuel consumption and minimum pollution, and affords starting in any weather conditions, outstandingly in the cold.

**Satellite Control:** Citroën designers have created a separate satellite module holding the most essential controls within finger-touch of the hand while it is on the steering wheel. These controls are, at the top, the two-speed windscreen wiper and electrically operated washer; in the centre, the direction indicator and horn; at the bottom, controls for full beam, dipped and side lights, headlight dip switch and headlight flasher.

**Brakes:** The Visa front brakes are new Citroën disc brakes set in the wheels, using opposed twin pistons. Both brakes are fitted with wear indicators, and the pad area of the two front wheels is 22.32 square inches. The two-shoe drum brakes at the rear have a lining area for both wheels of 24.5 square inches. There is the Citroën dual-circuit hydraulic control. A pressure limiter prevents rear wheels locking under heavy braking. Rear drums have an automatic wear take-up device.

**'Elastic Bumpers':** The Visa has novel 'elastic bumpers', in reality shield type bumpers of thermoplastic elastomer fitted to metal cross members. The Visa Super has protective shields on the same substance along its side. This does not quite convert the Visa into a Dodgem car but the bumpers not only offer protection in case of impact but are sufficiently elastic to resume their shape after minor bumps of the sort endured when other drivers misjudge their parking space.



652cc engine

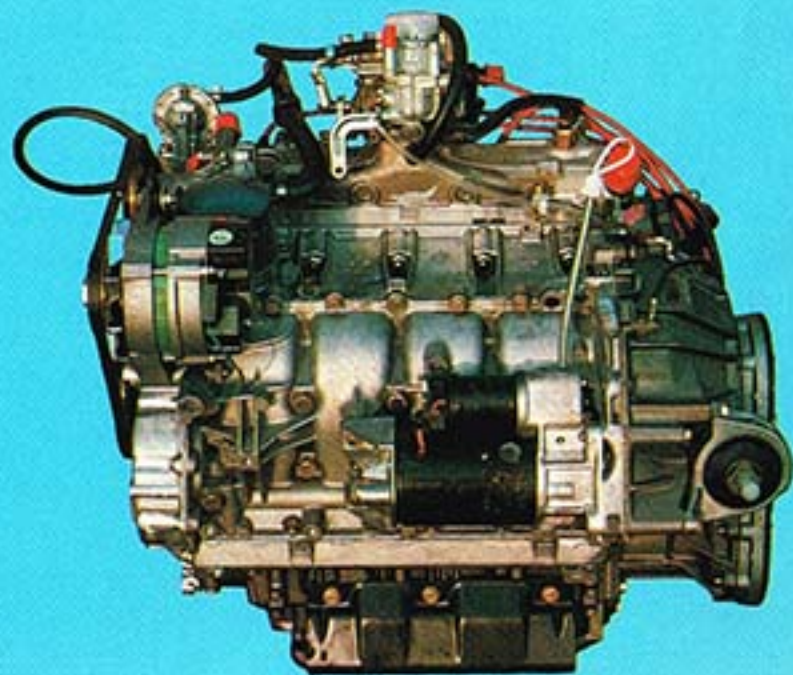

1124cc engine

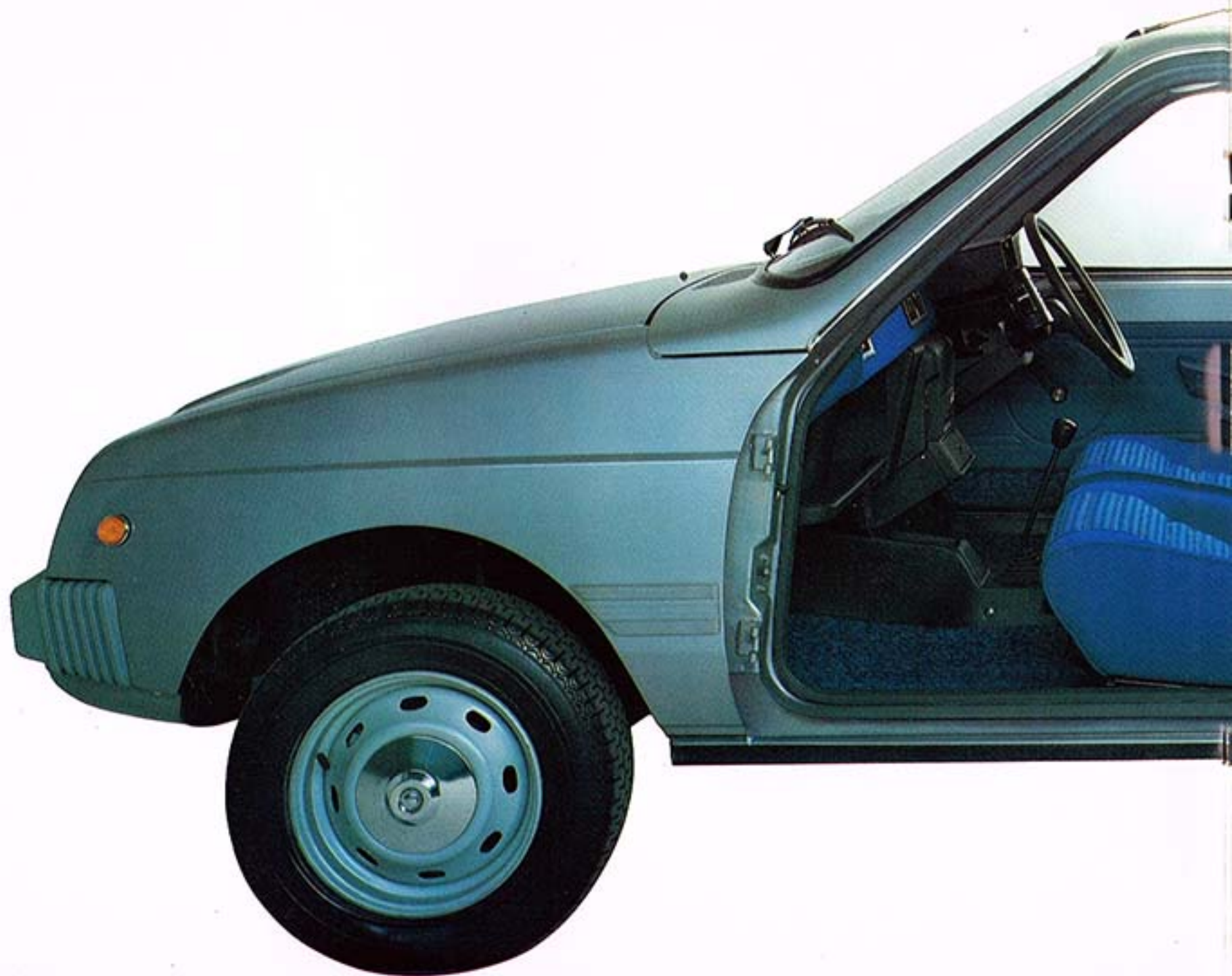



**Visa Super**

## What you may be surprised to find in the Visa

The Citroën Visa incorporates as standard equipment various features and advantages that you might not expect in a car of its type and price.

The rear window is electrically heated. The electric washer/wiper is standard.

There is a single large high-pressure two-speed windscreen wiper, with electrically operated washers.

There are demisters operating on the side windows. In all there are seven air vents ventilating the passenger compartment, with a special control for rear seat heating or ventilation. A two-speed blower allows the cool-or-hot-air input to be adjusted at will.

Front seat inertia belts are standard and retraction housings are flush-sunk. Anchorage points for rear seat belts are fitted. The rear door locks have child-safety catches.

There are four capacious oddments-tidies including two on the inside of the front doors.

Front seats recline and are upholstered in Jersey cloth.

Reversing lamps and high intensity fog lamps are standard.

When heavily loaded headlamp beams can be adjusted from inside the car.

Brake fluid levels can be checked at the push of a button.

Twin rear mounted speakers, roof aerial and electrical suppression are standard, so enabling you to fit radio or stereo cassette player at minimal cost.





## **Aerodynamics:**

Careful attention to designing a 'clean' aerodynamic shape which has two prime effects: saves on fuel because less energy is needed to push the Visa through the air; improves stability in cross winds because air currents tend to bend around the car instead of pushing it off the road.

## **Visibility:**

The Visa, with its sharply-dipping bonnet, provides excellent visibility forward. The windscreen is swept comprehensively by a single wiper which since it always travels parallel to the airflow over the car can never lift off at any speed.

## **Accessibility:**

The tailgate lifts high. You stow without knocking yourself out. The foldaway rear seat presents a flat floor surface.

## **Exit-ability without excitability:**

The four side-doors extend almost at right angles when opened. Every passenger can get out like a human, not like trapped elephants. Each door is fitted with a red reflector to tell the world when it's open.

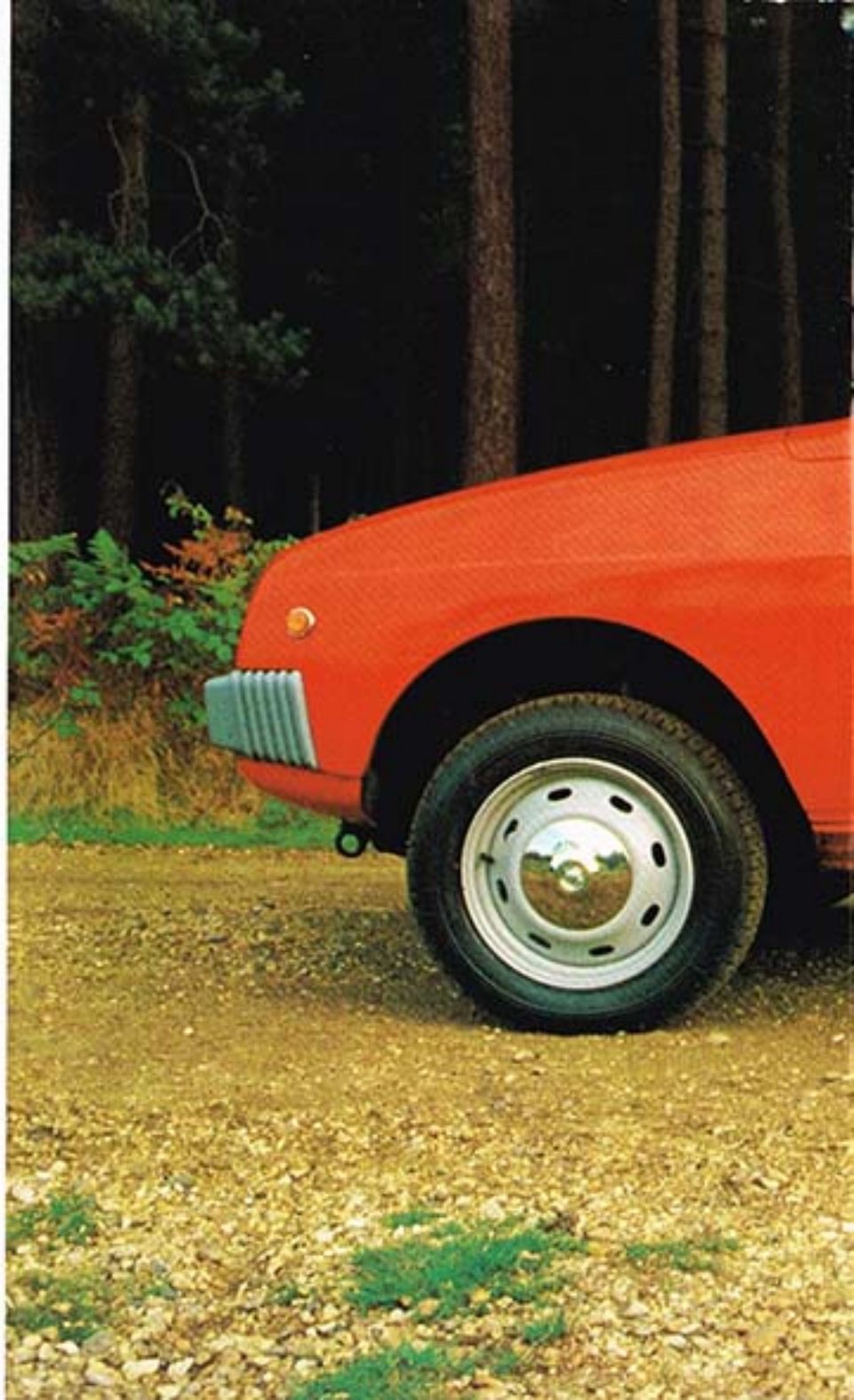



## Quality in the Visa:

Every Visa which leaves our factories in France and Belgium must be as near perfect as we can make it. At various stages during assembly a veritable army of quality control inspectors descend on the car, check list in hand, to ensure every detail is up to standard.

Particular care is taken with paint finish, bodies are first cleaned and dried. They are then run through tunnels where a phosphate solution gives a surface to the metal which acts as a corrosion barrier and ensures good paint adhesion.

The shells are then totally immersed in electrophoretic tanks to ensure every nook and cranny is covered with an even spread of anti-corrosion primer. Next a surfacer is applied, followed by two coats of paint.



But that's not all: for U.K. bound Visas, 'tectyl', a special protective coating is applied to underbody, wheel arches and other hollow sections. And before leaving France a further detail check is carried out. If they pass this test they are considered ready for shipment to this country where the Citroën dealer will carry out his own thorough check before handing the car over to the customer.

## Safety and the Visa:

Passenger compartment security is built in. The frontal position of the engine allows an intervening cushion of recoil. The under-frame has forward and rear units designed to contain kinetic energy in case of impact. The monocoque body is of great rigidity with deliberate lessening of load on the side panels to retain the fundamental resistance of the passenger compartment against deformation.

All round independent suspension with MacPherson struts at the front, and trailing arms at rear with a front anti-roll bar (also on rear of Super models) ensures good roadholding. Powerful brakes give more than adequate stopping power. Front wheel drive gives good traction even on slippery surfaces such as snow and ice.

Driver stress is catered for by the comfort and spaciousness which the Visa offers. Good ventilation both front and rear and the very wide range of warning and informing lamps and dials all contribute to the driver's peace of mind, and ensure he is in the best possible state to cope with any emergencies, should they arise.

## Citroën in the U.K.

The first Citroën plant was opened in Britain in 1926. However, it was in the early 'seventies that Citroën began to expand dramatically to deal with the rapidly growing demand for its cars.

Today, a network of over 260 dealers covers the entire country—with another 7,000 at hand if you take your car to the Continent.

Two special training schools provide courses for mechanics from every Citroën dealership in Britain to ensure that Citroën

owners receive the best care for their cars, combined with the highest level of efficiency. Around 1000 mechanics and service managers a year undergo comprehensive training.

All Citroën cars have a 12 months, unlimited mileage guarantee. This even covers the costs of roadside repairs and towing charges if necessary anywhere in Western Europe.



Citroën recently reduced parts prices by 17%—a move made possible by the increasing number of Citroëns on British roads. An ultra-modern 100,000 sq ft Replacement-Parts complex carries more than £3 million worth of parts at any given time to back up the £2½ million worth of stock distributed throughout Citroën dealers in Britain.

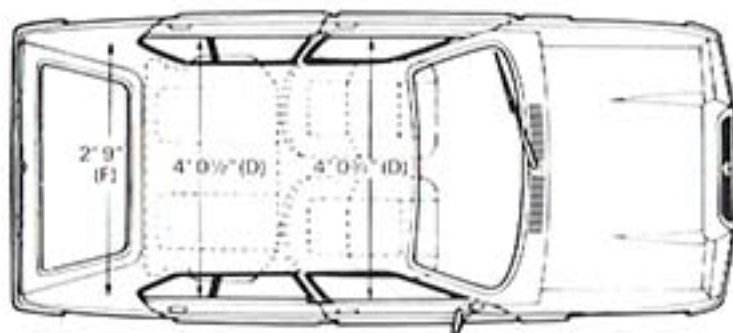
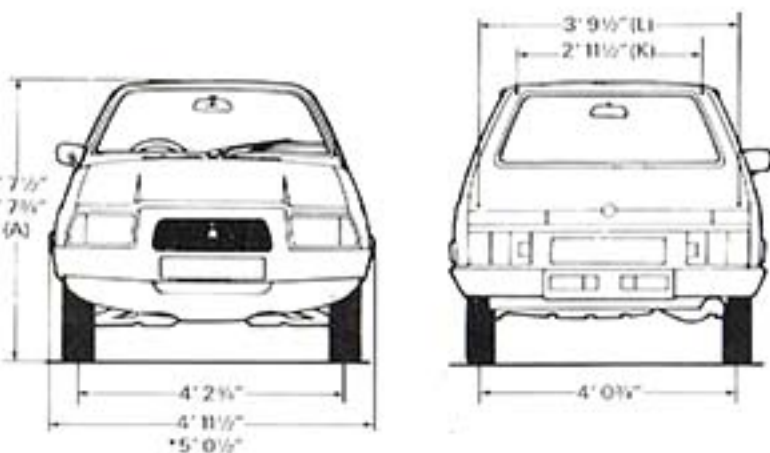
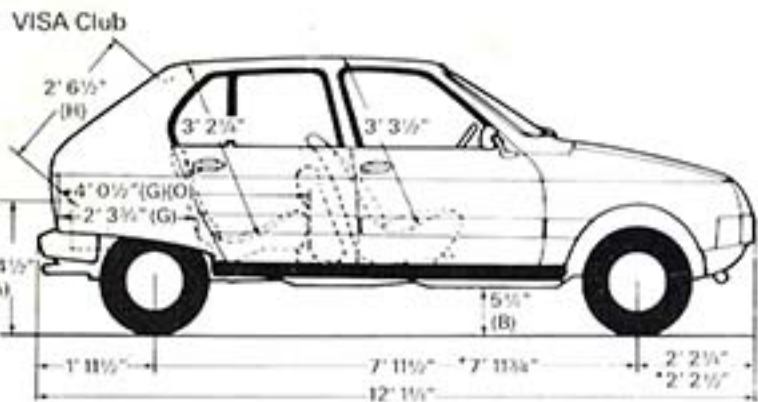

- A** : unladen  
**B** : laden  
**D** : width at shoulder-height  
**F** : between wheelarches  
**G** : floorpan length  
**H** : hatchback opening  
**K** : width of hatchback (top)  
**L** : width of hatchback (bottom)  
**Q** : rear seat folded  
 \* VISA Super

## TECHNICAL DATA

|                         | Visa Club  | Visa Super                               |
|-------------------------|--|--|
| Cubic capacity          | 652 cc   | 1124 cc                                  |
| Number of cylinders     | 2  | 4  |
| Cooling system          | Air-cooled   | Water-cooled, thermo-static electric fan |
| Battery                 | 12v 175/35 Ah  | 12v 175/35 Ah                            |
| Alternator              | 460 w  | 460 w                                    |
| Clutch                  | Single dry disc, cable operated  | Single dry disc, cable operated          |
| Transmission            | Front wheel drive with 4 synchromesh forward speeds; gear control by floor-mounted lever in centre console   |  |
| Steering                | Rack and pinion  | Rack and pinion                          |
| Construction            | Monocoque construction with deformable impact zones front and rear. Most body panels detachable  |  |
| Suspension              | Independent on all four wheels, using coil spring/damper, MacPherson struts and anti-roll bar at front; trailing arms and coil springs at rear. (Visa Super also fitted with rear anti-roll bar) |  |
| Capacities: fuel        | 8.8 gallons  | 8.8 gallons                              |
| engine oil              | 5.3 pints  | 7.9 pints                                |
| gearbox                 | 2.5 pints  |  |
| cooling system          | -  | 15.2 pints                               |
| Bore and stroke         | 77 x 70 mm   | 72 x 69 mm                               |
| Compression ratio       | 9:1  | 9.2:1                                    |
| DIN bhp                 | 36 @ 5500 rpm  | 57 @ 6250 rpm                            |
| DIN torque (lb ft)      | 38.5 @ 3500 rpm  | 59.3 @ 3000 rpm                          |
| Fuel supply             | Mechanical fuel pump, manual choke   | Mechanical fuel pump, manual choke       |
| Carburettor             | Twin choke   | Twin choke                               |
| Tyres                   | 135 SR 13 XZX  | 145 SR 13 XZX                            |
| Brakes                  | Dual circuit, discs at front, self-adjusting drums at rear.  |  |
| Load volume             | 6.65 cu ft   | 6.65 cu ft                               |
| Kerb weight             | 1620 lb  | 1764 lb                                  |
| Max load                | 728 lb   | 904 lb                                   |
| Gross vehicle weight    | 2348 lb  | 2668 lb                                  |
| Max trailer weight      | 1102 lb  | 1653 lb                                  |
| Top speed               | 77 mph   | 89 mph                                   |
| Fuel consumption: Urban | 36.7 mpg 4/100Km 7.7   | 33.6 mpg 4/100Km 8.4                     |
| Constant 56 mph         | 48.7 mpg 4/100Km 5.8   | 45.6 mpg 4/100Km 6.2                     |
| Constant 75 mph         | -  | 33.6 mpg 4/100Km 8.4                     |

(Official Govt. figures)



**NOTE:** The information contained in this brochure was accurate at the date of going to press (1st Nov. 1979). The company however reserves the right, while preserving the essential characteristics of the models described and illustrated, to introduce at any time modifications, changes of details, equipment or accessories as may be considered necessary to improve the models described or for any other reason of a constructional or operational nature. Every endeavour will be made to bring the brochure up to date from time to time but in order to avoid any misunderstandings any person interested should enquire of the company or its agents as to whether there have been material alterations since the date of the issue of this brochure. DIN (Deutsche Industrie Normen) figures are the most widely-accepted standard in the European motor industry.