

Ford

NEW CHASSIS CAB



Go Further

**VISIONARY. INGENIOUS. REMARKABLE.
EVERY VEHICLE BEARS HIS SIGNATURE.**

Henry Ford

CONTENTS

Introduction	02	Communication and connectivity	26
Interior	04	Driver Assistance Technologies.....	28
Chassis Cab/Skeletal Chassis range	06	Leader.....	38
Flexibility.....	10	Ford Transit One-Stop.....	40
Chassis Double Cab.....	12	Colour and trim	50
Chassis Double Cab range	14	Efficiency	52
Conversions.....	16	Own.....	54
Designed for efficiency	22	Specifications.....	56
Driveline options.....	24	Next steps	65



Model shown is a Transit Leader L2 H1 Chassis Single Cab in Magnetic metallic body colour (option).

Model shown is a Transit Leader L4 H1 Skeletal Chassis Single Cab in Frozen White solid body colour (standard).

Model shown is a Transit Leader L3 H1 Chassis Double Cab in Kapoor Red metallic body colour (option).

*Scan the QR codes to access additional content.
View Ford's remarkable history in action.*



Built for hard work

When there's serious work to be done, trust the new Ford Transit to be up to the job. Combining the strength of a heavy truck with the agility of a light commercial vehicle, every model in the extensive, easy-to-convert Chassis Cab range can be configured to satisfy your individual business needs.

Across the range, you'll find increased payloads and more fuel-efficient engines with greater torque and towing ability than before. Plus, a bold new front-end design with larger three-bar grille, a fresh bonnet and bumper, and distinctive new headlights with LED technology (option). Inside, there's built-in connectivity on selected models, and advanced driver assistance technologies available to help you through the toughest working day.

From a Luton van, dropside or tipper, to a refrigerated body, mobile workshop, emergency services vehicle or a motorhome, the new Transit Chassis Cab is the ideal transport solution.

Model shown is a Transit Leader L2 H1 Chassis Single Cab in Chrome Blue metallic body colour (option).



Your mobile office

New Transit helps you take even the most demanding day in your stride. The spacious, redesigned interior with its new instrument panel and high-quality ergonomic design puts you comfortably in control. A new 8" touchscreen at the heart of the fascia supports pinch and swipe gestures and delivers a range of information, entertainment and navigation, as well as voice control (option).

A choice of standard dual front passenger seat or fully-adjustable single seat offers room for up to three occupants, while the fascia-mounted gearshift provides easy cross-cab access. And, because life at the wheel runs more smoothly – and looks much better – when you have room to store everything you need, you'll find plenty of easily accessible stowage space too, including three open-topped bins on the top of the dashboard and a new device dock designed to hold a mobile phone or tablet.



Model shown is a Transit Leader L2 H1 Single Chassis Cab in Magnetic metallic body colour (option), with optional Ice Pack 21.

Chassis Cab

L2 (medium wheelbase)

FWD/RWD/AWD

3,500-4,700 kg GVM

2/3 seats

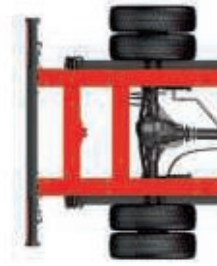

Dual rear wheel (DRW)

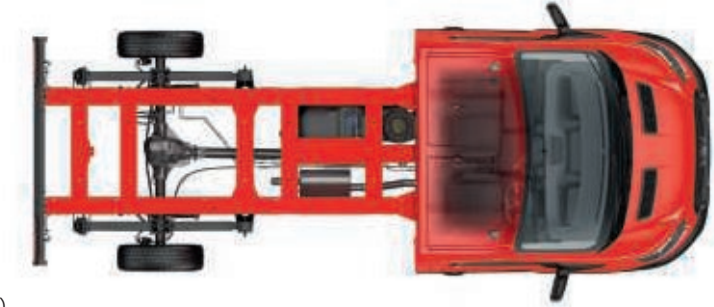

Single rear wheel (SRW)

L3 (long wheelbase)

FWD/RWD/AWD

3,500-4,700 kg GVM

2/3 seats

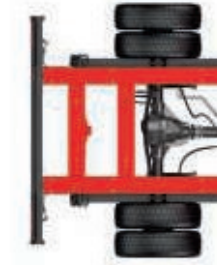

Dual rear wheel (DRW)



Single rear wheel (SRW)

L4 (long wheelbase with Extended Frame)

RWD (FWD available on 350 series)

3,500-4,700 kg GVM

2/3 seats



Dual rear wheel (DRW)

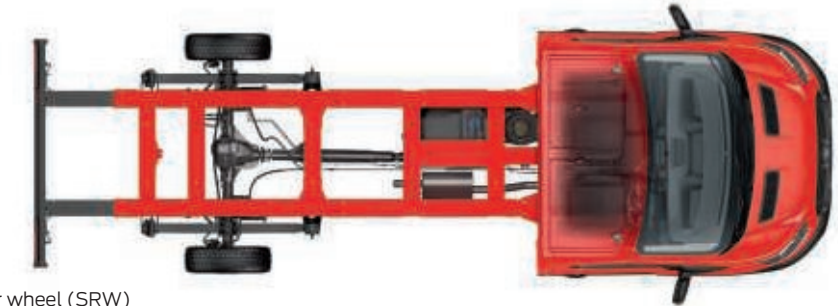

Single rear wheel (SRW)

L5 (extra-long wheelbase)

RWD

3,500-4,700 kg GVM

2/3 seats

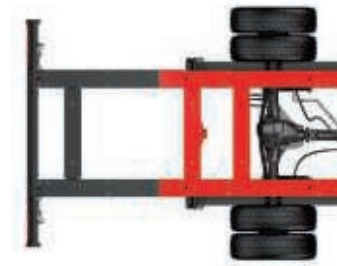

Dual rear wheel (DRW)

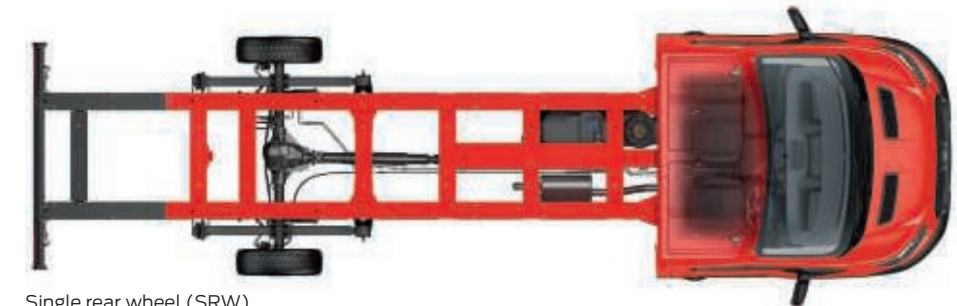

Single rear wheel (SRW)

Skeletal Chassis

L2 (medium wheelbase)
FWD
3,500 kg GVM
2/3 seats



L3 (long wheelbase)
FWD
3,500-4,100 kg GVM
2/3 seats



L4 (long wheelbase with Extended Frame)
FWD
3,500-4,100 kg GVM
2/3 seats



Skeletal Chassis

Single rear wheel (SRW)

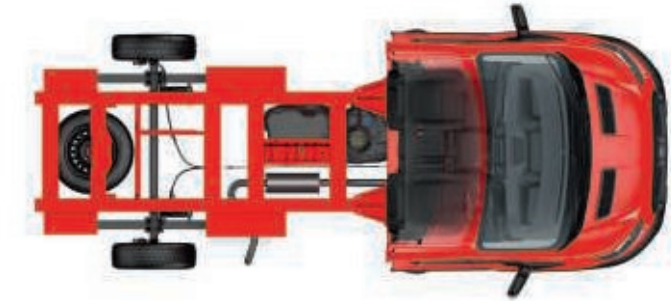

Single rear wheel (SRW)

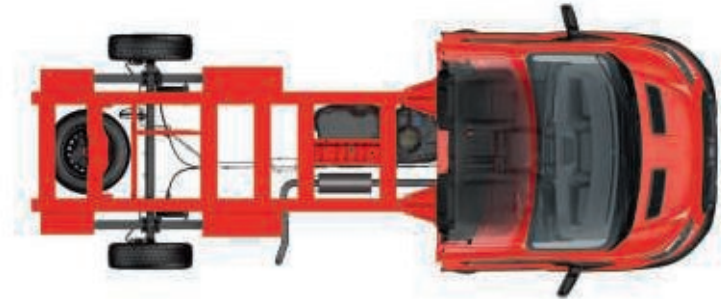

Single rear wheel (SRW)

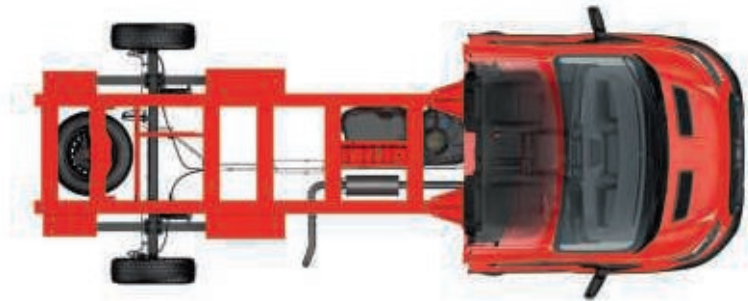

Recreational and passenger conversions.



Body conversions shown are for illustrative purposes only. Spare wheel shown is an option.
Note Technical information for vehicle converters can be found online via the Body and Equipment Mounting Manual at www.etis.ford.com; go to >information >>vehicle conversions.

Utility and cargo conversions.

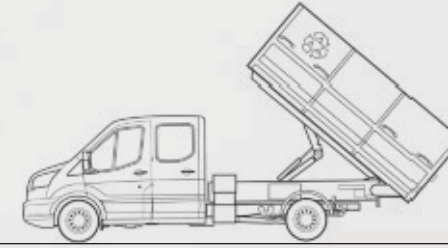

Outstanding flexibility

Transit Chassis Cab is the ideal vehicle range for specialist conversions. The combination of a high tensile steel frame construction, integral mounting points and low frame rails allow Transit to fulfil a multitude of tasks, with little or no modification.



In great shape for bodybuilding

Throughout Transit Chassis Cab's development we worked closely with the bodybuilding industry to ensure that all standard body types, and most bespoke solutions, can be fitted easily and efficiently. A choice of cab styles, frame lengths and driveline configurations provide a solid base for a variety of conversions, and mean that a wide range of adaptations is possible.

Emergency and wheelchair accessible conversions.



Utility and cargo conversions.

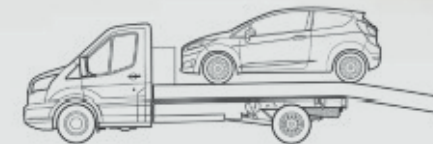

Room for you and your crew

When it comes to moving both cargo and a work team on-site, the new Transit Chassis Double Cab is a great solution.

Wide-opening doors provide easy access to the spacious and well thought-out interior. While the dual front passenger seat and standard rear quad seat together offer comfortable accommodation for up to seven occupants. The passenger seats feature lift-up base cushions and underseat stowage compartments, enabling tools and equipment to be carried out of sight. In addition, the front centre seat has a fold-down seat back that can convert into a handy work surface.

Available in four wheelbase lengths and with a choice of front-, rear- or all-wheel drive* configurations, new Transit Chassis Cab combines rugged load-carrying ability with versatile crew accommodation.

*All-wheel drive (AWD) is available as an option on L2 & L3 350 series models.

Model shown is a Transit Leader L2 H1 Chassis Double Cab in Kapoor Red metallic body colour (option).



Chassis Double Cab

L3 (long wheelbase)
RWD (AWD available on 350 series)
3,500-4,700 kg GVM
6/7 seats



L4 (long wheelbase with Extended Frame)
RWD
3,500-4,700 kg GVM
6/7 seats



L5 (extra-long wheelbase)
RWD
3,500-4,700 kg GVM
6/7 seats



Chassis Double Cab



Dual rear wheel (DRW)

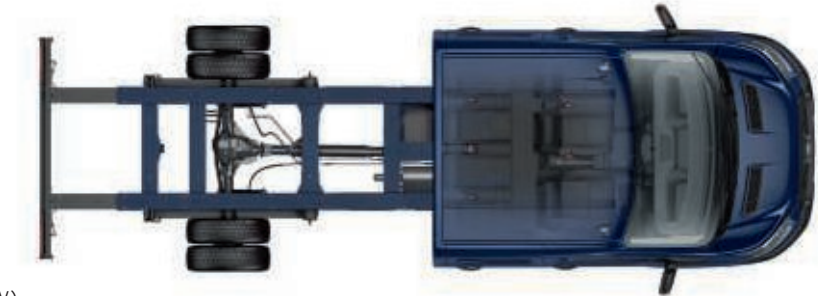

Dual rear wheel (DRW)

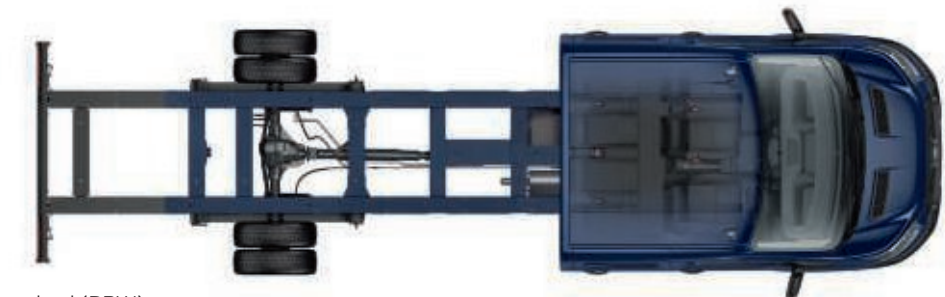

Dual rear wheel (DRW)

The converters' choice

With its strong platform, steel ladder-frame chassis and tough, load bearing ability, Ford Transit has long been a top choice for specialist bodybuilders and converters. All the traditional virtues and strengths of the Transit range, including the latest technology, durability and the support of Ford Transit24, our dedicated aftersales programme, are the starting point for tailored solutions that support the varying requirements of the conversion industry. And with the new Skeletal Chassis derivative joining the Transit Chassis Cab range, there are now even more reasons for converters to choose the proven foundation of Ford Transit.



736-738 mm*

Chassis Cab floor/chassis frame height

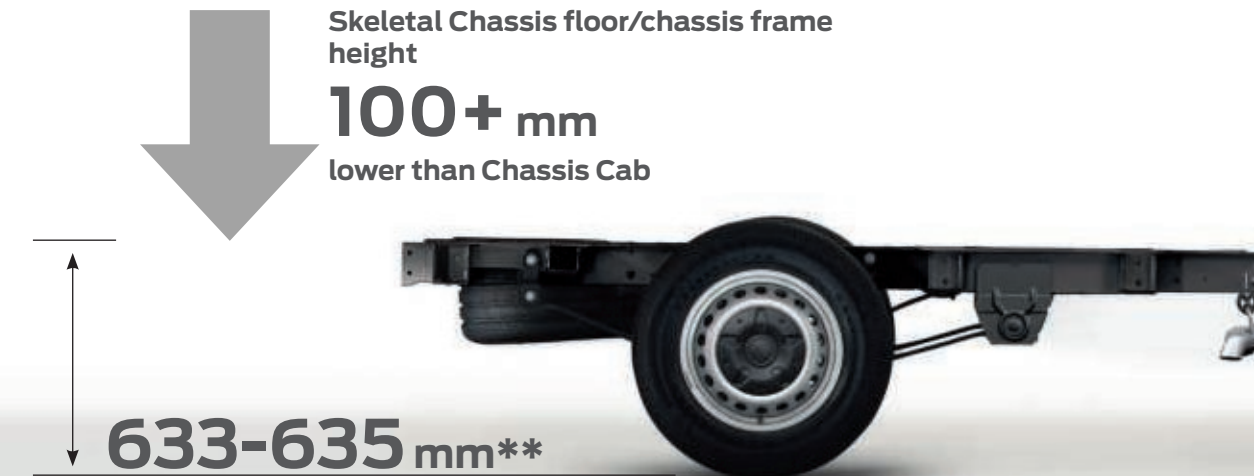

Skeletal Chassis floor/chassis frame height

100+ mm

lower than Chassis Cab

633-635 mm**

Skeletal Chassis floor/chassis frame height

Skeletal Chassis

The versatile new front-wheel drive Transit Skeletal Chassis models are engineered to provide strength and efficiency for almost any kind of use. Built on a unique full ladder frame chassis that's both strong and light, they offer the ideal solution for conversions requiring a low floor height, such as delivery vehicles, refrigerated applications, horse transportation and mobile shops.

- Strong, lightweight ladder frame chassis
- Reduced chassis rail height – approximately 100+ mm* lower than a standard Chassis Cab
- FWD low floor 3.5 tonne automatic
- Approximately 200 kg* payload advantage over standard Chassis Cab
- Two rear axle widths: 1,759 mm (standard on L2 and L3); 1,980 mm (standard on L4, option on L2 and L3)

*Depending on derivative.

Skeletal Chassis payload



1,761 kg - 1,845 kg*

Chassis Cab payload



1,297 kg - 2,755 kg*

*See Weights and loads table for more information.

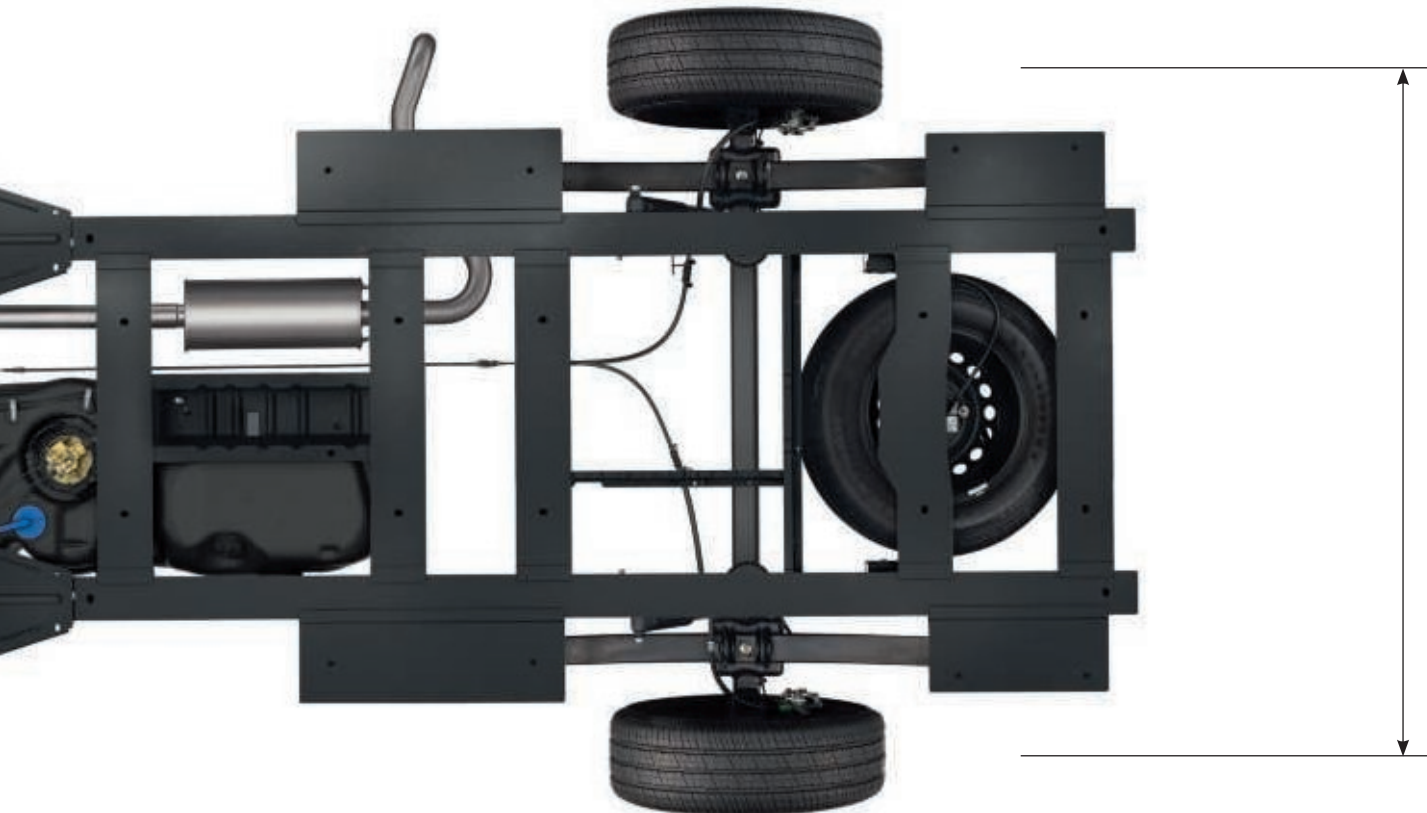

Standard rear axle
1,759 mm
Standard on L2 and L3 models.

Wide rear axle
1,980 mm
Standard on L4, option on L2 and L3 models.

Maximum conversion width
2,400 mm
(long arm mirrors required)

Internal wheel arch width
1,600 mm
(with wide rear axle)

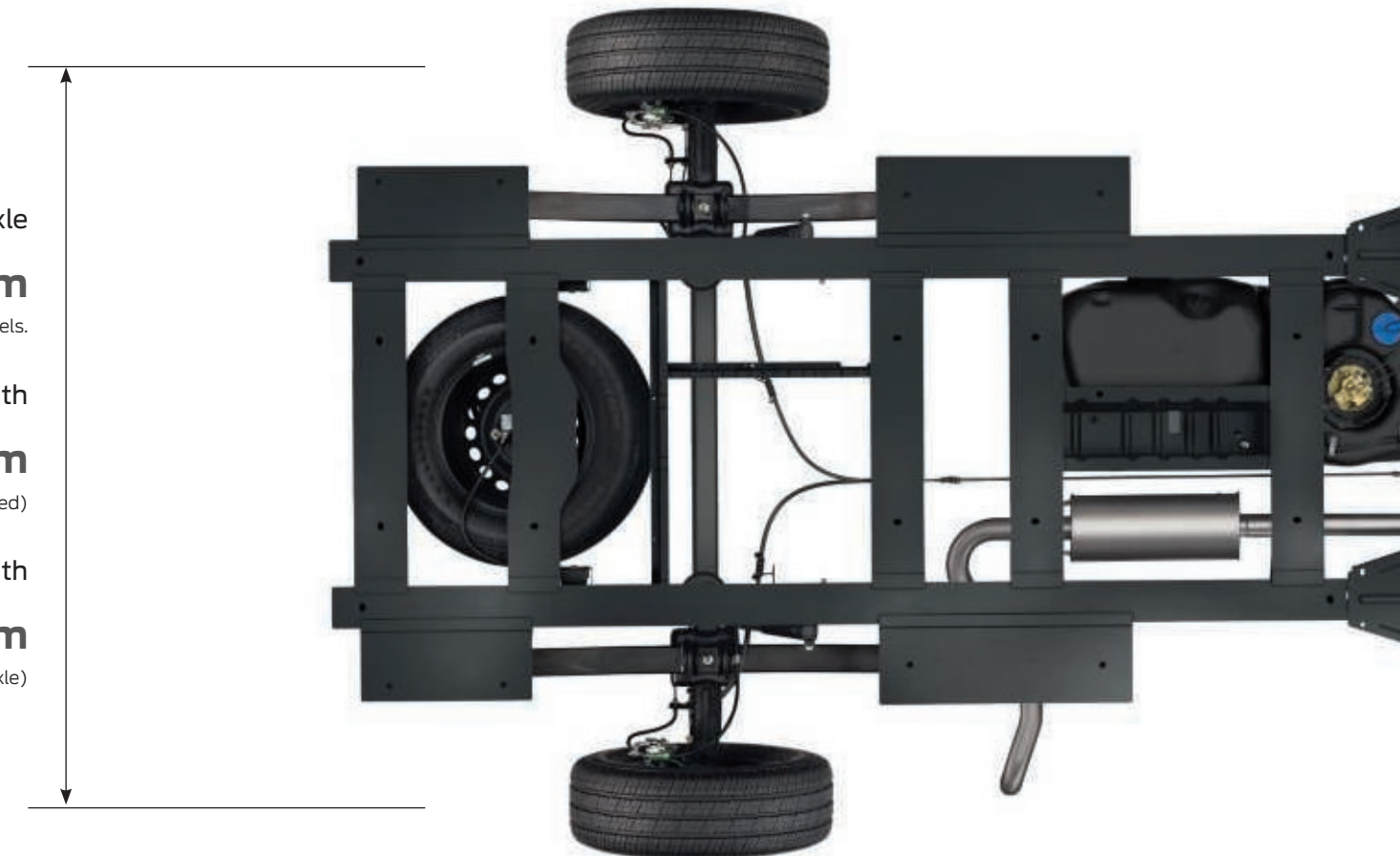



L2 3,142 mm (Single Cab)
L2 2,327 mm (Double Cab)

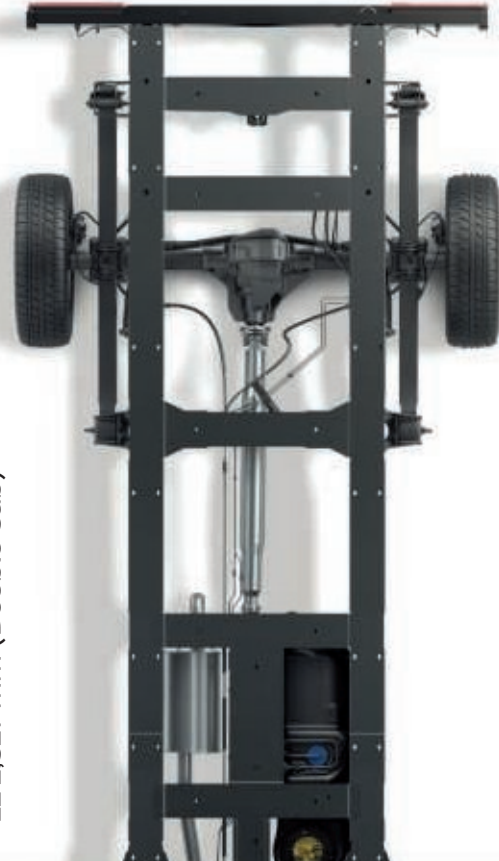

L3 3,592 mm (Single Cab)
L3 2,777 mm (Double Cab)



L4 4,149 mm (Single Cab)
L4 3,159 mm (Double Cab)



L5 5,147 mm (Single Cab)
L5 4,149 mm (Double Cab)

Making light work of heavy jobs

Tough, practical and versatile, new Transit Chassis Cab is designed to support your individual business needs. Each hard-working derivative, from the L2 (medium wheelbase) to the L5 (extra-long wheelbase), features a robust ladder-frame chassis that provides a flat, strong base on which to build. A range of driveline configurations, cab styles and single or dual rear wheel axles adds to its flexibility, for an extensive choice of conversions.

For the convenience of operators who want a quick and simple solution, our factory-built Transit floats are supplied ready to work and comply with the latest European Community Whole Vehicle Type Approval (WVTA) legislation.

Maximum conversion length:
5,970 mm

Note Frame lengths shown are for Chassis Cab models.



Designed for efficiency

New Transit brings together a range of vehicle features and technologies designed to deliver improved fuel economy, reduced emissions and lower cost-of-ownership (versus the prior generation model), without compromising on performance or functionality.

- 01 Vehicle maintenance monitor** Is designed to analyse your vehicle's data to help ensure the engine can perform at its best. Displays a range of information in the instrument cluster, including the oil life remaining, AdBlue® exhaust fluid distance to empty and water in fuel warning. (Standard)
- 02 Power-foldable mirrors** Electrically-operated and heated door mirrors with large spotter lens. Ideal for parking in tight spaces or squeezing through narrow lanes. (Option)
- 03 Acceleration Control** A unique engine calibration designed to limit acceleration when the vehicle is lightly laden, helping to reduce fuel consumption. (Option, not available with automatic transmission)
- 04 Auto Start-Stop** Automatically switches off the engine when you come to a halt and put the vehicle in neutral. Restarts when you want to move off, helping to reduce fuel consumption and exhaust emissions. (Standard)
- 05 Ford Easy Fuel capless refuelling system** A unique safeguard ensures that nobody can accidentally fill up with the wrong fuel. Plus, no dirty fuel caps to touch. (Standard)





Front-wheel drive (FWD)

- Engine availability: 105 PS/310 Nm; 130 PS/360 Nm; 170 PS/390 Nm
- Lower rear frame height provides greater flexibility for conversions
- Lower kerbweight for greater payload and fuel efficiency



Rear-wheel drive* (RWD)

- Engine availability: 130 PS/360 Nm and 170 PS/390 Nm
- Superior traction when heavily laden
- Best suited for heavier duty applications and towing



All-wheel drive** (AWD)

- Engine availability: 130 PS/360 Nm
- Driver-selectable AWD system provides extra traction in difficult terrain conditions
- Under normal conditions, drive is directed to the rear wheels. When engaged, the system automatically increases engine torque to the wheels with the most grip



Driving force

New Ford Transit is offered with a range of front-, rear- or all-wheel drive** derivatives. All engines drive through a 6-speed manual transmission as standard, with a 6-speed automatic transmission available as an option on front-wheel drive models***.

When the going gets tough, nothing beats the sure-footed performance of all-wheel drive. Available on selected models**, Transit's intelligent AWD system helps you achieve more confident progress on challenging surfaces.



SelectShift 6-speed automatic transmission

Delivers a smooth, relaxing driving experience, especially in heavy traffic. Provides the ability to lockout gears in more challenging driving conditions, e.g. on slippery surfaces or steep gradients. (Option on FWD models)

*RWD is available on Chassis Cab/Chassis Double Cab.

**All-wheel drive is available as an option on Transit Chassis Single and Double Cab (350 GVM).

***A new 10-speed automatic transmission will be available as an option for Transit Chassis Single Cab rear-wheel models built from early 2020. Please see your Ford Transit Specialist Dealer for more information.



Meet your phone's new best friend

Ford SYNC 3

Ford SYNC 3 integrates seamlessly with a compatible smartphone, letting you control everything from phone calls and text messaging to music and satellite navigation – all via the 8" touchscreen or through remarkably simple voice commands. Map updates help to keep you on track and on time, and are complimentary for a limited period following vehicle registration.

SYNC 3 features

- Manage your phone, music, apps and navigation with simple voice commands
- Hear your text messages read aloud for you
- Emergency Assistance† helps occupants place an emergency call to provide emergency services with the vehicle location in their respective language
- Control SYNC-compatible apps with AppLink, while Apple CarPlay and Android Auto let you navigate your smartphone through the SYNC 3 home screen, as if it were your handset

Colour touchscreen supports multi-touch 'swipe' and 'pinch-to-zoom' gestures, and lets you arrange application icons and background displays just as you would on your tablet or smartphone

- Access additional features via your smartphone with the **FordPass App**.
- Select points of interest along your route. FordPass will send these locations to your SYNC 3 Navigation when you connect through AppLink
- Search for refuelling points by brand or fuel grade, and compare pricing
- Search available parking spaces, check costs, opening hours and ratings

Please note: Full SYNC 3 smartphone integration is only available with iPhone 5/Android 5.0 (Lollipop) or higher. Some SYNC 3 functions require a data connection, so mobile data charges will apply. To check whether Apple CarPlay and Android Auto are available in your market, please check official Apple CarPlay and Android Auto websites for the latest information.

†Ford Emergency Assistance is an innovative SYNC feature that uses a Bluetooth®-paired and connected mobile phone to help vehicle occupants initiate a call to the local Communications Centre, following a vehicle crash event involving an airbag deployment or fuel pump shut off. The feature operates in more than 40 European countries and regions.

Born connected

Only Ford can deliver a fully connected ecosystem that is built-in from the start. The FordPass Connect* modem and the FordPass App make the job easier, unlocking a range of efficiency and security features.



Ford FordPass Connect

- **Live Traffic** (two year trial)** sends up-to-date traffic information directly to the SYNC 3 Navigation system. The technology then adjusts the recommended route based on the traffic conditions, so you waste less time on the way to your next job
- **On-board Wi-Fi** (three month trial)*** with speeds of up to 4G this enables mobile working for up to 10 devices. You can even use the hotspot from up to 15 m outside the vehicle for more efficient mobile working when you get to the site
- FordPass Connect features are provided as a two year free trial from date of first registration. After this, subscription charge will apply

Ford Data Services™†

With Ford Data Services™ and FordPass Connect you can receive vehicle data securely to either your own telematics application or via your chosen Telematics Service Provider. Data available includes: vehicle health, vehicle location, fuel usage and driving characteristics, and can be received on multiple vehicles. Data can be integrated with your existing in-house application or your chosen Telematics Service Provider.



- **Remote Lock & Unlock** lets you check if the vehicle is locked and to lock it remotely, no matter how far away you may be
- **Find** nearby parking spaces and filter the results by minimum vehicle access height
- **Vehicle Status** helps drivers keep on top of basic maintenance, quickly check they have enough fuel and that the tyre pressures (excluding DRW vehicles) are correct for the current load

Ford Telematics™†

With Ford Telematics™ and FordPass Connect you can easily view data and manage all your vehicles using our intuitive user dashboard. Receive data on multiple vehicles including: vehicle health, vehicle location, fuel usage and driving characteristics. The information is presented with actionable insights that deliver the data you need to manage your fleet.

*FordPass Connect is an optional extra. The on-board modem will be connected at the time of vehicle delivery. You may choose to opt in/out of certain data sharing. The technology will be made available in selected markets in 2019, with the remaining markets following through 2020.

**Live Traffic access is complimentary for the first 2 years following the registration of a new Ford featuring SYNC 3 Navigation; thereafter a licence fee is payable.

***Wi-Fi hotspot (up to 4G LTE) includes complimentary wireless data trial that begins at the time of Wi-Fi hotspot activation and expires at the end of 3 months or when 3GB of data is used, whichever comes first. Afterwards, additional data bundles can be purchased from Vodafone. Please refer to their website for details of their data packages. To take advantage of the built-in Wi-Fi hotspot capability, a 2019 Ford vehicle must come with the appropriate hardware, and a data plan is required. Data coverage and service is not available everywhere and terms of your data plan, including applicable message and data rates, may apply.

†Ford Data Services™ and Ford Telematics™ require a valid contract and account subscription. Available to eligible business customers.



Setting the pace

Set your own pace with Intelligent Adaptive Cruise Control⁽²⁾. The system can identify the prevailing speed limit and maintain your selected speed within the limit detected. Advanced radar technology scans for slower traffic in front of you, and can automatically adjust your speed to maintain a preset gap from the vehicle ahead. When the traffic has cleared, your vehicle will resume its pre-selected speed. (Option, requires SYNC 3 with Navigation, available via Ice Pack 25)

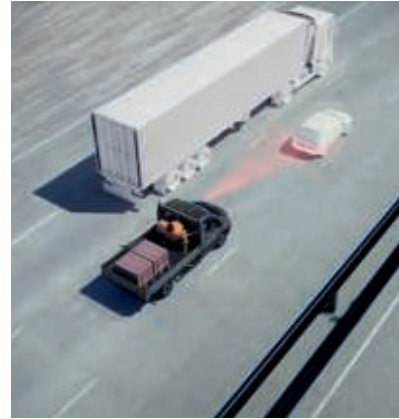

Intelligent Adaptive Cruise Control⁽²⁾

Combines Intelligent Speed Limiter with Adaptive Cruise Control and Traffic Sign Recognition to identify the prevailing speed limit and automatically restrict the vehicle's speed within the limit detected. (Option, requires SYNC 3 with Navigation, available via Ice Pack 25)

Model shown is a Transit Leader L2 H1 in Magnetic metallic body colour (optional).

⁽¹⁾Uses sensors.
⁽²⁾Driver assistance feature.





Keep in lane

It only takes a momentary slip in concentration to drift out of your lane when driving on the motorway. Transit's Lane-Keeping Alert^{0*2)} (option, not available with AWD) is designed to recognise when you approach lane markings without using the indicator, and warn you with vibrations through the steering wheel. If you fail to react, Lane-Keeping Aid^{0*2)} (option) can apply steering torque to help you keep within your marked lane.



Side Wind Stabilisation⁰²⁾

Helps the driver to stay in lane in strong, gusty conditions by using the ESC system to sense when the vehicle is being affected by crosswinds. (Standard)

Model shown is a Transit Leader L2 H1 in Magnetic metallic body colour (optional), with optional Fog Lights.

⁰⁾Uses sensors.

^{*}Operates at speeds over 65 km/h on multi-lane roads with clearly visible lane markings.

¹⁾Safety feature.

²⁾Driver assistance feature.





Model shown is a Transit Leader Chassis Single Cab L3 H1 in Magnetic metallic body colour (option).

Thinking ahead

Using camera and radar technology, Pre-Collision Assist⁽²⁾ with Pedestrian Detection* (standard on 470 derivatives on Single/Double Chassis, option elsewhere) can monitor your proximity to other vehicles and pedestrians*. If a potential collision is detected, it can alert you with audible and visual warnings and, if needed, pre-charge the brakes and increase brake sensitivity to help provide full responsiveness when you brake. If the system determines a collision is imminent, Active Braking⁽²⁾ may automatically apply full braking to help mitigate the effect of an impact. (Option)



Pre-Collision Assist⁽²⁾ with Pedestrian Detection*

Using radar and a camera, the system is designed to detect other vehicles and pedestrians* and can alert you to a potential collision. (Option)

⁽¹⁾Uses sensors.

⁽²⁾Driver assistance feature.

*Pedestrian Detection is designed to operate at vehicle speeds of up to 80 km/h. In darkness, the object to be detected must be within the range of the headlight beams.

Features to help make your life easier



Selectable Drive Modes

Enables you to switch between four drive modes – Normal, Eco, Snow, Tow/Haul. The system adjusts various settings, including throttle response and steering feel, to help make driving easier in certain conditions. (Availability depends on the vehicle drivetrain)

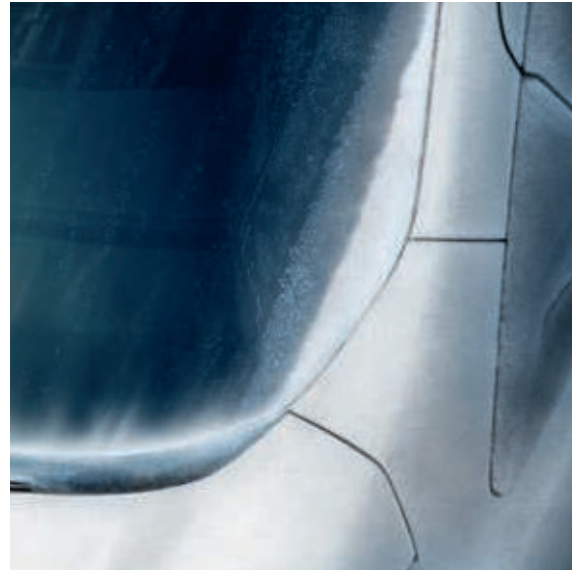

Quickclear heated windscreen

Clears ice or demists the windscreen quickly, even on frosty mornings for year-round comfort and visibility. (Option)



Vehicle maintenance monitor

Analyses your vehicle's data to help optimise engine performance. Displays a range of information in the instrument cluster, including the oil life remaining, AdBlue® exhaust fluid distance to empty and water in fuel warning. (Standard)



Ford EcoBlue diesel engines

Ford Transit's 2.0-litre Ford EcoBlue is a completely new generation of advanced, high-performance diesel engines. Available with a choice of power and torque outputs, the refined and efficient Ford EcoBlue diesels build on the industry-leading performance and technology of our acclaimed multi-award-winning Ford EcoBoost petrol engines.



Hill Start Assist⁰²⁾

Designed to temporarily prevent your vehicle from rolling down a slope when you move your foot from the brake pedal to the accelerator pedal. It works in forward and reverse gears, so is ideal for towing and pulling heavy loads. (Standard)

⁰⁾Uses sensors.

²⁾Driver assistance feature.



Curve Control⁰¹⁾

Senses when a driver takes a curve too quickly, and can rapidly reduce engine torque – and apply brakes to individual wheels – to help keep the vehicle under control. (Standard)

⁰⁾Uses sensors.

¹⁾Safety feature.

Special Vehicle Options

While the Ford Commercial Vehicle range already offers an extensive choice of off-the-shelf features and options, the Special Vehicle Options (SVO) programme goes a step further. Practical options range from heavy-duty batteries to a choice of over 100 colours to match your company's livery. SVO availability varies by region and model. Please check with your local Ford Transit Specialist Dealer.



Special paints

Your company's livery is an important business asset, so Transit is available in a huge range of colour options.



Ford programmable battery guard

This patented battery guard system helps to prevent a flat battery. Set a time for battery use without the engine running, create profiles for battery use (heavy or light use, with and without additional batteries) and protect your battery from starter motor overload. This highly functional unit is packed with features. (Option)



High electrical power system

Specially developed for Transit Conversions with heavy power needs, such as emergency vehicles, refrigeration units and maintenance vehicles. (Option)

System contains:

- High performance AGM batteries
- Engine rpm control



Twin high performance AGM batteries

Available for higher electrical loads, providing improved reliability when deep-cycling. (Option)



High specification interface connector

This comprehensive connector provides access to power supply vehicle signals that facilitate conversions. Signals include engine start, engine run, stop light, door open, turn indicators, vehicle speed and handbrake on. (Option)



Utility vehicle switch pack

Provides switches for beacon and power equipment for utilities. For example, road maintenance crew van with water heater, additional lighting and beacons. Consists of 3 switches and wiring - 1 x beacon switch and 2 x 12 V auxiliary switches.

The auxiliary switches are positioned in the 2-DIN overhead console and can be used for powering various functions, for example, work lights, water heater, or power to a rear tailgate. (Option)



Beacon preparation pack

Beacons are fitted on many vehicle conversions, including road maintenance, recovery vehicles and emergency services. This pack provides a switch and electrical wiring for ease of fitting. (Option)



Trailer tow electrics

If you need to fit a unique tow bar to your Transit Conversion, then our trailer tow electrics pack will let you safely and legally connect power to your trailer. It contains a sturdy connector and the wiring necessary to operate your trailer's lights. (Option)

Leader

Key exterior features

- Power-adjustable and heated self colour door mirrors (L4 Skeletal Chassis only)
- Daytime running lights
- Headlights with courtesy delay
- Door mirrors with integrated side indicators (not available on L4 Skeletal Chassis)
- Roof marker lights (not available on Skeletal Chassis)
- Side marker lights (L3 and L4 for Chassis Double Cab and L4 only for Chassis Single Cab) (not available on Skeletal Chassis)
- 16" steel wheels with half caps
- Half cap wheel covers (front wheels only for dual rear wheel models)
- Wide bodyside mouldings

Key interior features

- Single-DIN radio, four front speakers (two woofers and two tweeters), remote audio controls and USB connectivity port with iPod® functionality
- MyKey
- Vehicle Maintenance Monitor
- Trip computer
- Electrically-operated front windows
- Driver's airbag
- Partial rubber floor cover (Chassis Single Cab and Skeletal Chassis only)
- Extended rubber floor cover (Chassis Double Cab only)
- Front 2-way head restraint
- Seat back fold-down table
- 4-way adjustable driver's seat with cushion tilt and armrest
- 2-way adjustable passenger's seat
- Rear second-row quad seats (Chassis Double Cab only)
- Pre-Collision Assist (only on 470 derivatives)



Engines

Diesel

- 2.0 TDCi Ford EcoBlue 105 PS (77 kW)
- 2.0 TDCi Ford EcoBlue 130 PS (96 kW)
- 2.0 TDCi Ford EcoBlue 170 PS (125 kW)



Model shown is a Transit LeaderL2 H1 Chassis Single Cab in Race Red solid body colour.



Ford Transit One-Stop

Ford Transit is renowned for its versatility and flexibility, Transit is the ideal platform for a wide range of specialist applications and bespoke conversions. What's more, for the convenience of those operators who want a quick and simple, work-ready solution, Ford offers the Transit 'One-Stop' range of bodied Chassis Cabs.

One-Stop 1-way Tipper

Strong, rugged and purposeful, the Ford Transit Tipper represents superb functionality, with quality of design and manufacture. It is seen as a versatile, reliable partner by a wide range of industries where safety and productivity are paramount.

Tipper are expected to operate in adverse conditions and are subject to a wide range of payloads. SRW provides increased payload whilst Transit's DRW rear wheel drive configuration provides excellent traction and loading latitude often required on and off site.

Available in two cab formats: Single Cab; and the flexible Double Cab with crew seating and glazed crew doors as standard. Alternatively, no crew seating with windowless rear crew doors can be specified to form the basis of a Utility Cab conversion. This provides a secure load space behind the driver in the crew compartment. Optional bodywork equipment is available from the bodywork supplier via your Ford Transit Specialist Dealer. Typical options include polytarps, toolboxes, amber beacons, chevrons, ply or polypropylene load liners, rear light guards, and tow bars with a range of ball or clevis couplings and various pin electrical sockets.

Features include:

- 1-way rear tipping capability
- Powder-coated, hot-dipped galvanised steel construction
- Tough roll form to rear floor edge
- Body colour dual-skin aluminium side and tailboards
- Pull-up load-lashing points in load bed
- Sheeting hooks to underside of load bed, front headboard and rear
- Twin AGM battery electrical system
- Programmable Battery Guard
- 5-stage chrome-plated underfloor ram
- 2 kW electro-hydraulic power pack

- 45-degree tip angle
- Single rear wheel/Dual rear wheel (DRW Standard on 470)
- TÜV certification for safety and production conformity
- Machinery Directive - TUV 2006/42/EC 2009/19/EC conformity approved
- 3-year 100,000 mile warranty
- DRW Pack available as an option on 350 series. DRW standard on 470 series

Range available:

- Chassis Single Cab 1-way Tipper (L2)
- Chassis Double Cab 1-way Tipper (L3)

Chassis Cab L2 shown

Single rear wheel/dual rear wheel Pack available as an option on 350 series; DRW standard on 470 series

Internal body length 3220 mm

3,500-4,700 kg GVM*



Bottom-hinged tailboard

'Tip-over' tailboard configuration controlled by latches mounted in the rear pillars, suitable for most applications, especially large bulk loads.



Dual-mode hinged tailboard

Standard dual-mode top and bottom-hinged tailboard. Top-hinged or 'Tip-thru' operation controlled by side-mounted remote lever.



Tipper controls

Tipper 'Control Station' located adjacent to the driver's seat, houses all the Tipper controls.



Sequenced hydraulic body hold-down

Fully-automatic and controlled by hydraulic line pressures requiring no intervention by the operator.



Side pillar-mounted latches

Steel latches for sideboards and tailboard. Handle folds out of the way when unlatched and is removable for repair or replacement.



Tool pod

Sturdy lockable storage unit designed to help protect tools against theft and weathering.

Model shown is a Transit Leader L2 H1 Single Chassis Cab in Frozen White solid body colour.

*Please refer to Weights and Loads section for more information. Production models may vary from those shown.

One-Stop 3-way Tipper

The Ford Transit 3-way Tipper is engineered to the same high standards as the 1-way Tipper, with the added benefits of tipping to both sides of the vehicle, as well as to the rear.

The 3-way Tipper represents the ultimate in site vehicle versatility, and is especially useful on sites with restricted access. In addition to the standard dual mode top and bottom hinged tailboard, the sideboards can be retained by chains to dispense the load away from the vehicle, or dropped fully to allow easy material loading and off-loading.

Robustness and durability are qualities that every Tipper operator is looking for. Any items that are likely to get damaged or worn are designed to be replaced and maintained easily, helping to reduce downtime and maintenance costs.

Features include:

- 45-degree tip angle – rear, nearside, offside
- Chrome-plated 5-stage underfloor ram with built-in shock absorber
- Tough roll-form edge to load deck sides and rear
- Plug-in wander lead pendant control handset
- Twin AGM battery electrical system
- Programmable Battery Guard
- Top- and bottom-hinged tailboard
- Sideboard 90-degree retaining chains

- 3 year 100,000 mile warranty
- TÜV certification for safety and production conformity
- Machinery Directive - TUV 2006/42/EC 2009/19/EC conformity approved
- DRW Pack available as an option on 350 series. DRW standard on 470 series

Range available:

- Chassis Single Cab 3-way Tipper (L2)
- Chassis Double Cab 3-way Tipper (L3)

Chassis Cab L2 shown

Single rear wheel/dual rear wheel Pack available as an option on 350 series; DRW standard on 470 series

Internal body length 3220 mm

3,500-4,700 kg GVM*



Remote wander lead handset

Plugs into socket below driver's seat giving the operator control when side tipping.



Configuration bar

Ensures correct fitment of pivot index pins to enable side or rear tip pivot configurations.



Pivot pins

Control the tip configuration by locking or releasing ball-and-socket body pivots.



Integral body prop

Essential for routine maintenance and inspection.

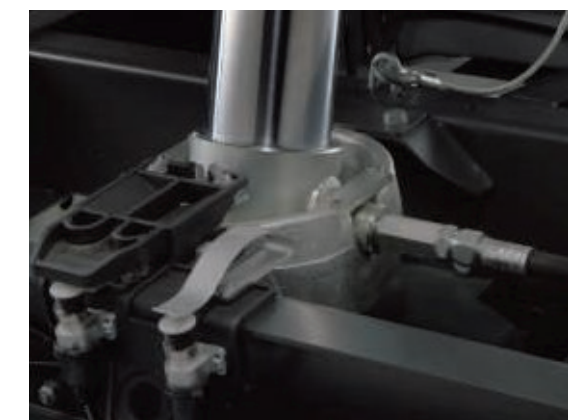

5-stage chrome-plated underfloor ram

Mounted in a steel gimbal with electrical limit switches controlling angle of tip.



Top-hinged tailboard

'Tip-thru' tailboard ideal for 'fluid' loads, such as sand, gravel and top-soil.

Model shown is a Transit Ambiente L2 H1 Single Chassis Cab in Frozen White solid body colour.

*Please refer to Weights and Loads section for more information. Production models may vary from those shown.

Premium and Standard Dropside

The Ford Transit Premium and Standard Dropside are stylish, easy-to-drive vehicles for operators seeking a cost-effective, yet professional image for their business. Body lengths available are L2 to L5 and payloads range up to 2,391 kg. To compliment the Premium Dropside various accessories are available to ensure more specific requirements are met.

From 2.93 to 5.30 metres, there is a model to suit most operating needs.

- Available on Single Cab L2 - L5 and Double Cab L3 - L4
- Load bed access is a key requirement for Dropside users, therefore on the Premium Dropside four steps are provided enabling access with the sideboards raised or lowered. In addition, two profiled grab handles ensure safe access for the operator
- A generous number of load anchor points are available on the Premium platform and headboard, ensuring the payload can always be safely retained
- To compliment the Premium Dropside a range of accessories are available
- Tail-lifts, load cranes, toolboxes, beacons and bespoke paint schemes can be specified on Premium Dropside to meet the demands of an increasing variety of operating tasks

Premium Dropside features include:

- Replaceable resin-bonded 15 mm ply load deck
- Substantial all-steel powder-coated headboard
- Double Skinned body colour aluminium sideboards and tailboards with integral bump rubber
- Flush-mounted load-lashing rings to raves, plus roping eyes to underside of raves plus roping eyes to underside of raves
- Robust, lightweight aluminium and steel subframe
- Wider range of powertrains, drive lines and GVM's available

- Premium Dropside available L2 - L5
- Single and double cab FWD, RWD, AWD and Automatic
- ESC/ABS/Hill Start Assist
- ECWVTA 2007/46/EC Approved

Range available:

- Single Chassis Cab L2 - L5 350 - 470 GVM
- Internal body lengths - 2850 - 5223 mm
- Double Chassis Cab L3 - L4 350 - 470 GVM

Standard Dropside features include:

- Stainless steel tailboard 90 degree retainers
- Fold-out step access to bed with step in tailboard
- Aluminium unpainted side and tail boards
- Headboard lashing/D Rings
- Factory produced reducing lead times
- Additional 100 kg payload versus Premium Dropside model comparison
- ESC/ABS/Hill Start Assist

Range available:

- Single Chassis Cab L2 350 105 PS FWD only
- Internal body length 3205 mm

Standard Dropside L2 shown
GVM* 350 105 PS FWD
Single rear wheel
Internal body length 3205 mm

3,500 kg GVM*

Model shown is a Transit Leader L2 H1 Single Chassis Cab in Frozen White solid body colour.



Chassis Cab L4 shown
Premium Dropside
Single rear wheel/Dual rear wheel
FWD/RWD/AWD
Internal body length 4230 mm
3,500-4,700 kg GVM*



Fold-out steps

Allow access with sideboards lowered.
Model shows Premium Dropside



Sheeting hooks

Underfloor-mounted hooks for securing load sheets.
Model shows Premium Dropside



Load anchors

Pull-up load retention rings sit flush with the load platform when not in use.
Model shown Premium Dropside

*Please refer to Weights and Loads section for more information. Production models may vary from those shown.

Luton Chassis Cab L4 shown

Front-wheel Drive

Single rear wheel

Chassis frame Length 4,149 mm



Skeletal Chassis Luton Van L3 shown

Front-wheel Drive

Single rear Wheel

Chassis frame Length 5771 mm



Internal spot light

Rear-mounted halogen spot light with switch, adjustable to allow coverage inside and outside of the load area. (LED with PIR on FWD Models)



Grab handle and step

Standard nearside bulkhead mounted grab handle with optional side underrun guard step, tubular stirrup step fitted as standard.

Images may differ between converter.

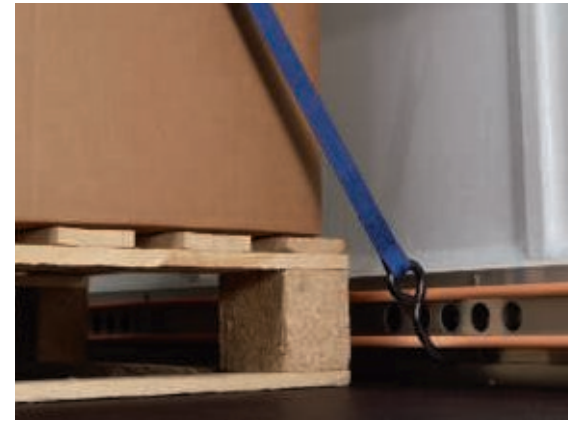

Load anchors

Load anchorage points located in the lower rail.



Rear shutter

Wide-slat rear shutter gives maximum internal headroom.

One-Stop Luton

Built to handle the demands of multi-drop distribution, Transit Luton Vans are available with a choice of traditional Chassis Cab or new Skeletal Chassis underpinnings. The addition of Front-Wheel Drive, in both L3 and L4 Chassis Cab versions, provides even more choice and offers increased payload versus RWD. Polyester/Foam-Core panel construction is durable and robust enough to cope with everyday knocks. The FWD drivetrain is also available with the option of automatic transmission.

The steel door frame on FWD models includes the necessary fixation points for optional tail-lift installation.

A range of optional bodywork equipment provides true flexibility, allowing you to tailor the body to match your specific requirements.

With a choice of 130 PS or 170 PS all new Ford EcoBlueTDCi diesel engines, a comfortable cab and a host of convenient features, including an easy open rear shutter and translucent plastic roof, the Ford Transit Luton Van makes perfect sense all round.

FWD features include:

- Choice of Chassis Cab or new Skeletal Chassis frames
- Box constructed of 2 piece profile system. No externally visible fixations or sealing
- Dead lock aluminium slat roller shutter with Pull Bar Handle
- Internal emergency rear door release and sidewall-mounted load restraint rails
- 4.1 m and 3.5 m internal body length
- Up to 19.8 m³ load space capacity
- 15 mm phenolic resin-bonded one-piece plywood floor
- Full-width aluminium Hi Viz rear step for variants less Tail-lift
- 3 telescopic load retention poles
- Full-height internal access grab handle
- Body colour in Frozen White
- Luton Van products and optional features are ECWVTA compliant

Luton features include:

- 3735 - 4118 mm internal body lengths
- 15.5 cu m and 17.2 cu m loadspace
- Slam-shut, lockable UPVC slat shutter
- Internal emergency rear door release
- 15 mm phenolic resin-bonded one-piece plywood floor
- Full-width aluminium rear step
- Internal sidewall mounted load restraint rails
- 3 telescopic load retention poles supplied as standard
- Full height internal access grab handle
- Overhead storage
- Body colour in Frozen White
- ECWVTA2007/46EC Approved

Colour and trim

Choose the colour and trim that best reflects your business brand.

1. Leader

Insert: Quadrant in Dark Palazzo Grey
Bolster: City in Ebony

2. Leader

Insert: Crosshatch on Salerno in Dark Palazzo Grey
Bolster: Salerno Vinyl in Ebony

1.



2.



Frozen White
Solid body colour



Blazer Blue
Solid body colour*



Race Red
Solid body colour*



Moondust Silver
Metallic body colour*



Agate Black
Metallic body colour*



Kapoor Red
Metallic body colour*



Magnetic
Metallic body colour*



Chrome Blue
Metallic body colour*



Diffused Silver
Metallic body colour*

12-year perforation warranty

The Transit Chassis Cab owes its durable exterior to a thorough multi-stage painting process. From the wax-injected steel body sections to the hard-wearing top coat, new materials and application processes ensure it will retain its good looks for many years to come.

Note The images used are to illustrate body colours only and may not reflect the vehicle described. Colours and trims reproduced within this brochure may vary from the actual colours, due to the limitations of the printing processes used.

*Optional body colour. Please speak to your Transit Centre for more details.

Zinc coating

Phosphate coat

Electrocoat

Primer

Top coat

Clearcoat

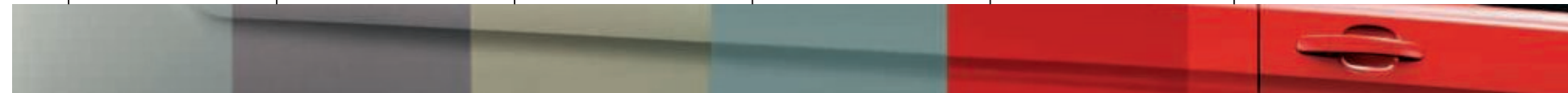

Efficiency

The power of choice

From power and torque to fuel economy and refinement, each engine in the next-generation Ford EcoBlue diesel range has been optimised to cater for all needs. Engineered to meet the latest Euro 6.2 emissions standards, the upgraded engines are even cleaner and more fuel efficient than their predecessors, returning fuel economy improvements of up to 7 per cent when compared with the previous powertrains.

Key fuel-saving technologies include*

- Auto Start-Stop system
- Ford Smart Regenerative Charging
- Gearshift indicator light - to aid economical driving
- Electric power-assisted steering (EPAS)
- Aerodynamic design improvements
- Low rolling resistance tyres

Heavy Duty Stage 6 diesel engines

To comply with the latest emissions regulations, any regular production or converted vehicle with a reference mass of 2,840 kg[†] or over (except motorhomes, ambulances and hearses), must meet HDT requirements. Therefore, Transit Chassis Cab is available with a 130 PS or 170 PS Heavy Duty diesel engine, in addition to the Light Duty powertrains.

[†]Reference mass = vehicle weight with 100% liquids, 90% fuel and driver allowance.

Note For further fuel economy and emissions information, please refer to the specifications section.

***Note** Some of the features listed above are options, at extra cost and may not be available on all models. Please refer to the specification tables, or speak to your Ford Commercial Vehicle Dealer for further information.

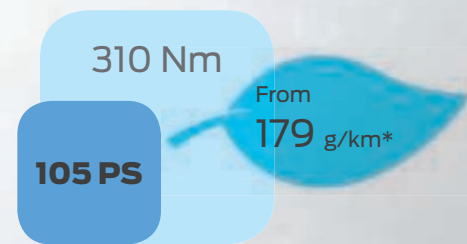

Efficient

2.0L Ford EcoBlue 105 PS diesel engine

Transit's new 2.0-litre Ford EcoBlue 105 PS (77 kW)/310 Nm diesel engine combines fuel efficiency with excellent driveability and refinement. Its state-of-the-art design helps to keep running costs down without compromising on payload or performance.

*105 PS N1 from 179g/km. NEDC Combined Cycle test figures, for more information see the fuel and Performance section

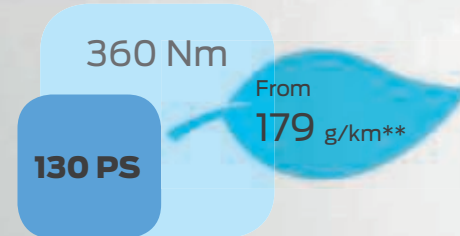

Flexible

2.0L Ford EcoBlue 130 PS diesel engine

The latest 2.0-litre Ford EcoBlue 130 PS (96 kW)/360 Nm diesel engine strikes a balance of delivering extra power and torque necessary to enhance Gross Train Mass (GTM).

**130 PS from 179g/km. NEDC Combined Cycle test figures, for more information see the fuel and Performance section.

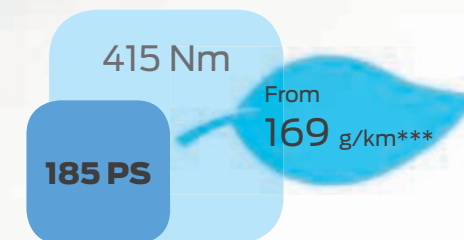

Powerful

2.0L Ford EcoBlue 185 PS diesel engine

The new 2.0-litre Ford EcoBlue 185 PS (138 kW) diesel engine develops an impressive 415 Nm of torque. As the most powerful engine in the range, its hard-working character makes it the ideal choice for moving heavy loads and towing, while still delivering fuel efficiency***.

***185 PS from 169g/km. NEDC Combined Cycle test figures, for more information see the fuel and Performance section

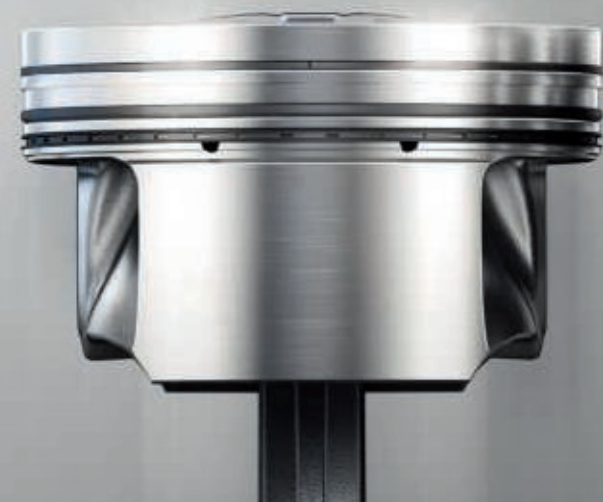

Clean diesel technology

Ford EcoBlue diesel engines

New Transit's range of upgraded Ford EcoBlue diesel engines meets the latest stringent Euro 6.2 emissions standards.

Ford EcoBlue diesel engines have been fitted with a Selective Catalytic Reduction (SCR) system that uses AdBlue®, a urea/water-based fluid to convert NO_x emissions in the exhaust gas into nitrogen and water vapour. Diesel vehicles are also fitted with a diesel particulate filter which reduces more than 99% of emitted solid particulates from the vehicle's exhaust.



Our business is to keep your business moving.



FORD BUSINESS SERVICE

Efficiency, accuracy and convenience are at the heart of the Ford Transit24 commercial vehicle service promise. Therefore, whether it is servicing, maintenance or repair you need, be sure to come and see us.

- Available from all Transit Centres and Transit Service dealers
- While-you-wait servicing by prior appointment
- Late night servicing available at least once per week
- Priority treatment for urgent repairs
- Vehicle off the road repairs (VOR)*
- Collection and delivery**
- Testing and MOTs
- Transparent pricing
- Genuine Ford parts quality
- Ford-trained technicians
- Interim checks for optimum vehicle performance
- Service Activated Roadside Assistance†
- Ford Protect packages to suit you
- One Call to access all the Ford services you need

For more information and to find your nearest participating Ford Commercial Vehicle Dealer, visit the aftersales support section at www.ford.co.uk/transit24

Commercial Vehicle Finance

When it comes to financing your Ford Commercial Vehicle, our size and expertise means we're well placed to provide you with a wide range of finance products.

Ford Credit[°]: Provides a range of finance plans for Commercial Vehicle customers interested in owning their vehicle.

Ford Lease[°]: Specialises in contract hire and leasing and provides an alternative range of finance plans which can be tailored to suit your business.

FORD PROTECT

Commercial Extended Warranty

Extend your warranty up to 5 years (from date of registration), with Ford Protect available at participating Ford Dealers.

Extend your standard 3-year warranty and enjoy worry-free motoring for many years to come. Ford Protect provides a range of key benefits including:

- Extended duration and mileage
- Cover against unexpected repair costs
- Protection on trips abroad
- With a Ford Protect Plan, the price of parts and labour are guaranteed for the length of your plan
- Helps prolong the lifespan of your Ford vehicle

Helps protect your vehicle resale value

Ford Protect terms and conditions apply for further information please call 03702 416 726.

^{*}Repairs will start on the same working day (as long as you bring your vehicle in before 3pm), or at least within 24 hours of its arrival. If we need to order parts, we'll begin work the day they're delivered. 'Vehicle off road' repairs should be completed within 24-hours.

^{**}Your Transit Centre can arrange to collect your vehicle and deliver it back to you after service or repairs, so you can get on with running your business. By arrangement and limited to a specific mileage radius of the dealer. Contact your local dealer to discuss your requirements.

[†]Available at participating Dealers only. Roadside Assistance is activated automatically at every routine service with coverage extended valid from the date of service for 12 months, or until the next service is due, whichever comes first. See Ford.co.uk/roadsideassistance for more information.

Important Information:

[°]Ford Credit: Finance subject to status. Guarantees may be required. Freepost Ford Credit.

Ford Credit is a trading style of FCE Bank plc, which is authorised by the Prudential Regulation Authority and regulated by the Financial Conduct Authority and Prudential Regulation Authority under firm reference number 204469.

[°]Ford Lease: Ford Lease is provided by ALD Automotive Ltd, trading as Ford Lease, Oakwood Drive, Emersons Green, Bristol, BS16 7LB. ALD Automotive is registered in England No. 987418. For the purposes of the Data Protection Act 1998 the data controllers in relation to any information you supply are Ford Motor Company Limited, FCE Bank Plc and ALD Automotive. Finance subject to status. Guarantees and indemnities may be required. ALD Automotive is authorised and regulated by the Financial Conduct Authority.

Chassis Single Cab

L2



L3



L4



L5



Skeletal Chassis Single Cab

L2



L3



L4



Chassis Double Cab

L3



L4

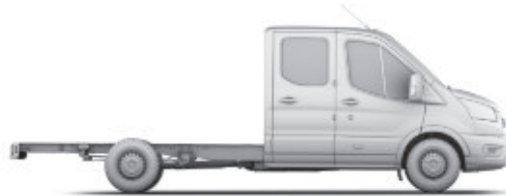

L5

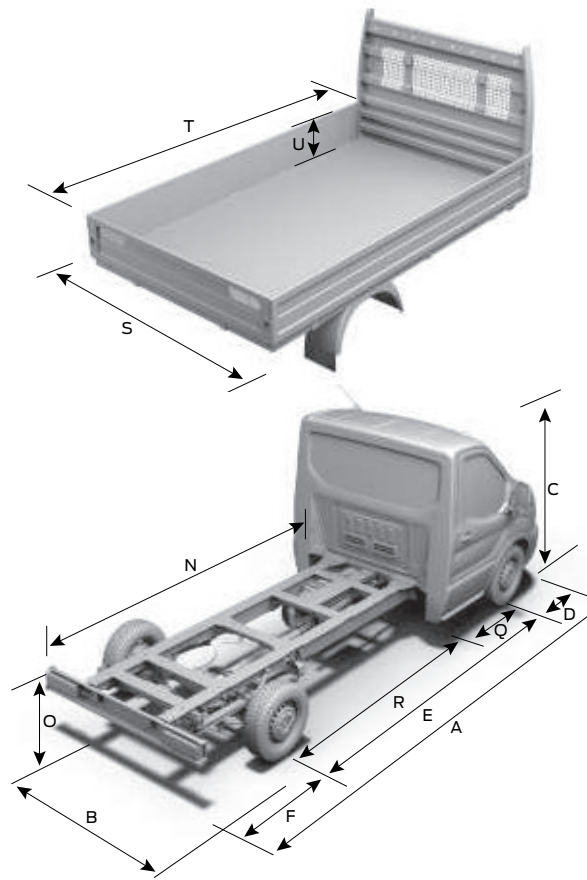

Dimensions (mm)

	L2 Chassis – Single Cab		L3 Chassis – Single Cab		L4 Chassis – Single Cab		L5 Chassis – Single Cab
	FWD	RWD/ AWD	FWD	RWD/ AWD	FWD	RWD/ AWD	RWD/ AWD
A Overall length	5572	5572	6022	6022	6579	6579	7577
B Overall width with mirrors (standard/wide)	2474/na	2474/2746	2474/na	2474/2746	2474/na	2474/2746	2474/2746
Overall width with folded back mirrors (standard/wide)	2112/na	2112/2119	2112/na	2112/2119	2112/na	2112/2119	2112/2119
Overall width without mirrors (SRW/DRW)	2052/na	2052/2111	2052/na	2052/2111	2052/na	2052/2111	2066/2111
C Overall height (maximum)	2200	2220	2194	2214	2195	2215	2208
D Front of vehicle to front wheel centre	1023	1023	1023	1023	1023	1023	1023
E Wheelbase	3504	3504	3954	3954	3954	3954	4522
F Rear of vehicle to rear wheel centre	1045	1045	1045	1045	1602	1602	2032
N Chassis frame length	3142	3142	3592	3592	4149	4149	5147
O Floor/chassis frame height*	704/747	723/766	715/742	718/763	720-758	722/779	715/784
Q Rear of cab to front wheel centre	1407	1407	1407	1407	1407	1407	1407
R Rear of cab to rear wheel centre	2097	2097	2547	2547	2547	2547	3115
S Standard rear wheel track	tba	tba	tba	tba	tba	tba	tba
Wide rear wheel track	-	-	-	-	-	-	-
Float dimensions (mm)**							
Overall length (including float)	5767	5767	6204	6204	6797	6797	7797
Overall width (including float) without mirrors (SRW/DRW)	2098/n/a	2098/2198	2098/n/a	2098/2198	2098/n/a	2098/2198	2198
Internal loadspace width (SRW/DRW)	2038/na	2038/2138	2038/na	2038/2138	2038/na	2038/2138	2138
Internal loadspace length	3205	3205	3645	3645	4235	4235	5235
Turning circle (m)							
Kerb to kerb	12.6	12.6	14.0	14.0	14.0	14.0	15.8

L2 = Medium wheelbase, **L3** = Long wheelbase, **L4** = Long wheelbase extended length, **L5** = Extra long wheelbase extended length. **FWD** = Front-wheel drive, **RWD** = Rear-wheel drive, **AWD** = All-wheel drive, **SRW** = Single rear wheel, **DRW** = Dual rear wheel. All dimensions (shown in mm) are subject to manufacturing tolerances and refer to minimum specification models and do not include additional equipment. *Height dimensions show the range from minimum to maximum of a fully laden, lowest payload vehicle to unladen highest payload vehicle. These illustrations are for guidance only. **Note: These dimensions are subject to manufacturing tolerances of +/- 50 mm and were correct at the time of going to print. All bodywork and equipment must be fitted in accordance with the Transit Body and Equipment Mounting Manual.

Dimensions (mm)

	L2 Skeletal Chassis FWD	L3 Skeletal Chassis FWD	L4 Skeletal Chassis FWD
A Overall length	5321	5771	5975
B Overall width with mirrors (standard/wide)	2474/2746	2474/2746	2474/2746
Overall width with folded back mirrors (standard/wide)	2112/2119	2112/2119	2112/2119
Overall width without mirrors (SRW/DRW)	2052	2052	2052
C Overall height (maximum)	2207	2201	2200
D Front of vehicle to front wheel centre	1023	1023	1023
E Wheelbase	3300	3750	3954
F Rear of vehicle to rear wheel centre	998	998	998
N Chassis frame length	2951	3401	3605
O Floor/chassis frame height*	633-635	633-635	639-641
Q Rear of cab to front wheel centre	1347	1347	1347
R Rear of cab to rear wheel centre	1953	2403	2607
S Standard rear wheel track	1759 ●	1759 ●	–
Wide rear wheel track	1980 ○	1980 ○	1980 ●
Turning circle (m)			
Kerb to kerb	11.9	13.3	14.0

L2 = Medium wheelbase, **L3** = Long wheelbase, **L4** = Long wheelbase extended length, **FWD** = Front-wheel drive, **SRW** = Single rear wheel (shown in mm) are subject to manufacturing tolerances and refer to minimum specification models and do not include additional equipment. *Height dimensions show the range from minimum to maximum of a fully laden, lowest payload vehicle to unladen highest payload vehicle. These illustrations are for guidance only. ****Note:** These dimensions are subject to manufacturing tolerances of +/- 50 mm and were correct at the time of going to print. All bodywork and equipment must be fitted in accordance with the Transit Body and Equipment Mounting Manual.

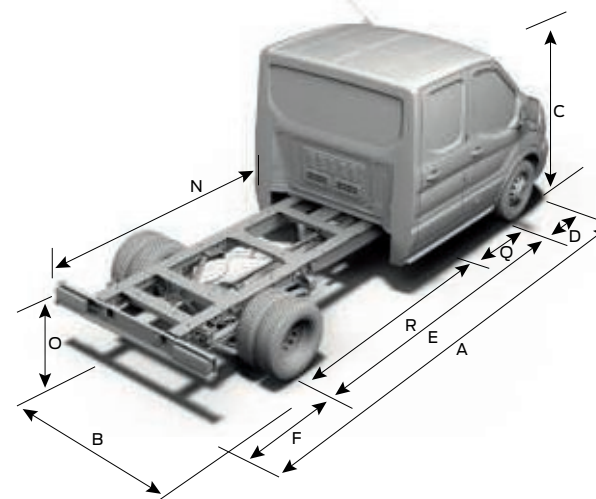
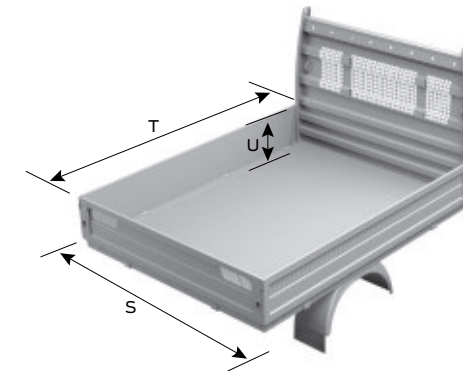
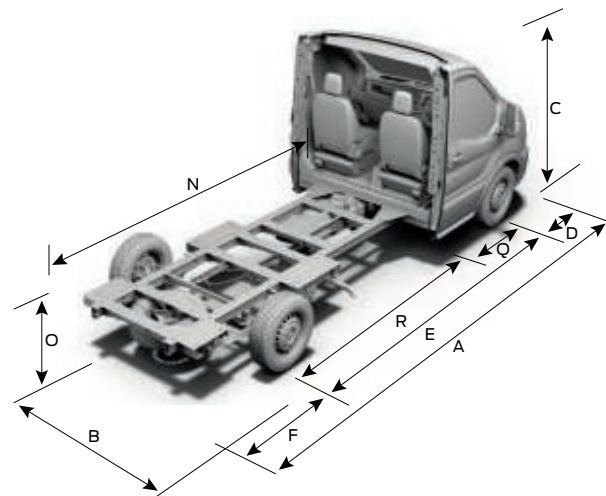

Dimensions (mm)

	L2 Chassis – Double Cab		L3 Chassis – Double Cab		L4 Chassis – Double Cab	L5 Chassis – Double Cab
	FWD	RWD/ AWD	FWD	RWD/ AWD	RWD/ AWD	RWD/ AWD
A Overall length	5572	5572	6022	6022	6404	7394
B Overall width with mirrors (standard/wide)	2474/na	2474/2746	2474/na	2474/2746	2474/2746	2474/2746
Overall width with folded back mirrors (standard/wide)	2112/na	2112/2119	2112/na	2112/2119	2112/2119	2112/2119
Overall width without mirrors (SRW/DRW)	2066/na	2066/2111	2066/na	2066/2111	2066/2111	2066/2111
C Overall height (maximum)	2236	2241	2230	2233	2233	2230
D Front of vehicle to front wheel centre	1023	1023	1023	1023	1023	1023
E Wheelbase	3504	3504	3954	3954	3954	4522
F Rear of vehicle to rear wheel centre	1045	1045	1045	1045	1427	1849
N Chassis frame length	2327	2327	2777	2777	3159	4149
O Floor/chassis frame height*	702/742	721/762	710/737	712/760	715/760	710/775
Q Rear of cab to front wheel centre	2222	2222	2222	2222	2222	2222
R Rear of cab to rear wheel centre	1282	1282	1732	1732	1732	2300
Float dimensions (mm)**						
Overall length (including float)	5767	5767	6204	6204	6587	7612
Overall width (including float) without mirrors (SRW/DRW)	2098/na	2098/2198	2098/na	2098/2198	2098/2198	2098/2198
Internal loadspace width (SRW/DRW)	2038/na	2038/2138	2038/na	2038/2138	2038/2138	2038/2138
Internal loadspace length	2385	2385	2795	2795	3205	4235
Turning circle (m)						
Kerb to kerb	12.6	12.6	14.0	14.0	14.0	15.8

L2 = Medium wheelbase, **L3** = Long wheelbase, **L4** = Long wheelbase extended length, **L5** = Extra long wheelbase extended length, **FWD** = Front-wheel drive, **RWD** = Rear-wheel drive, **AWD** = All-wheel drive, **SRW** = Single rear wheel, **DRW** = Dual rear wheel. All dimensions (shown in mm) are subject to manufacturing tolerances and refer to minimum specification models and do not include additional equipment. *Height dimensions show the range from minimum to maximum of a fully laden, lowest payload vehicle to unladen highest payload vehicle. These illustrations are for guidance only. ****Note:** These dimensions are subject to manufacturing tolerances of +/- 50 mm and were correct at the time of going to print. All bodywork and equipment must be fitted in accordance with the Transit Body and Equipment Mounting Manual.

Fuel economy and CO₂ emissions (EU6.2)

The fuel economy figures quoted in the table below are achieved by following strict EU governed test procedures and are specifically designed to enable customers to compare vehicles from all manufacturers on a like-for-like basis. Fuel consumption is directly affected by the length of the journey; number of passengers and amount of luggage carried; individual driving style; road and traffic conditions; weather conditions; vehicle age, mileage, condition and standard of maintenance; use of vehicle features such as air conditioning; and any modifications to the vehicle such as the addition of a roof rack. Your fuel economy will vary based on these and other factors and, for these reasons, many drivers may not achieve the EU fuel economy figures (below) in day-to-day driving, although the vehicle is technically capable of doing so.

	Axle ratio ⁰⁰⁰	CO ₂ emissions (g/km) ⁰⁰⁰	Fuel consumption in L/100 km ⁰⁰⁰		
			Urban	Extra Urban	Combined
Single Cab Chassis					
FWD					
2.0 TDCi Ford EcoBlue 105 PS (77 kW)	4.429/3.263	179	7.2	6.6	6.8
2.0 TDCi Ford EcoBlue 130 PS (96 kW)	4.429/3.263	179	7.2	6.6	6.8
2.0 TDCi Ford EcoBlue 130 PS (96 kW)	4.93/3.450	179	7.5	6.4	6.8
2.0 TDCi Ford EcoBlue 130 PS (96 kW) 6-speed automatic	3.39	182	7.3	6.4	6.9
2.0 TDCi Ford EcoBlue 170 PS (125 kW)	4.429/3.263	169	7.2	6.1	6.4
2.0 TDCi Ford EcoBlue 170 PS (125 kW)	4.93/3.450	172	7.2	5.8	6.5
2.0 TDCi Ford EcoBlue 170 PS (125 kW) 6-speed automatic	3.39	174	7.3	6.0	6.6
2.0 TDCi Ford EcoBlue 185 PS (136 kW)	4.429/3.263	169	7.2	6.1	6.4
2.0 TDCi Ford EcoBlue 185 PS (136 kW)	4.93/3.450	172	7.2	5.8	6.5
2.0 TDCi Ford EcoBlue 185 PS (136 kW) 6-speed automatic	3.39	174	7.3	6.0	6.6
RWD					
2.0 TDCi Ford EcoBlue 130 PS (96 kW)	3.31/3.73	181	7.3	6.4	6.9
2.0 TDCi Ford EcoBlue 130 PS (96 kW)	4.10	194-205	9.2	6.3-7.1	7.4-7.8
2.0 TDCi Ford EcoBlue 170 PS (125 kW)	3.31/3.73	169-181	7.3	6.0-6.5	6.5-6.9
2.0 TDCi Ford EcoBlue 170 PS (125 kW)	4.10	194-205	9.2	6.3-7.1	7.4-7.8
2.0 TDCi Ford EcoBlue 185 PS (136 kW)	3.31/3.73	169-181	7.3	6.0-6.5	6.5-6.9
2.0 TDCi Ford EcoBlue 185 PS (136 kW)	4.10	201-205	9.2	6.7-7.1	7.7-7.8
AWD					
2.0 TDCi Ford EcoBlue 130 PS (96 kW)/170 PS (125 kW)	4.10	245	11.1	8.3	9.3

Fuel economy and CO₂ emissions (EU6.2)

	Axle ratio ⁰⁰⁰	CO ₂ emissions (g/km) ⁰⁰⁰	Fuel consumption in L/100 km ⁰⁰⁰		
			Urban	Extra Urban	Combined
Double Cab Chassis					
FWD					
2.0 TDCi Ford EcoBlue 130 PS (96 kW)	4.429/3.263	179	7.2	6.6	6.8
2.0 TDCi Ford EcoBlue 130 PS (96 kW)	4.93/3.450	179	7.5	6.4	6.8
2.0 TDCi Ford EcoBlue 130 PS (96 kW) 6-speed automatic	3.39	182	7.3	6.4	6.9
2.0 TDCi Ford EcoBlue 170 PS (125 kW)	4.429/3.263	169	7.2	6.1	6.4
2.0 TDCi Ford EcoBlue 170 PS (125 kW)	4.93/3.450	172	7.2	5.8	6.5
2.0 TDCi Ford EcoBlue 170 PS (125 kW) 6-speed automatic	3.39	174	7.3	6.0	6.6
2.0 TDCi Ford EcoBlue 185 PS (136 kW)	4.429/3.263	169	7.2	6.1	6.4
2.0 TDCi Ford EcoBlue 185 PS (136 kW)	4.93/3.450	172	7.2	5.8	6.5
2.0 TDCi Ford EcoBlue 185 PS (136 kW) 6-speed automatic	3.39	174	7.3	6.0	6.6
RWD					
2.0 TDCi Ford EcoBlue 130 PS (96 kW)	3.31/3.73	181	7.3	6.4	6.9
2.0 TDCi Ford EcoBlue 130 PS (96 kW)	4.10	194-205	9.2	6.3-7.1	7.4-7.8
2.0 TDCi Ford EcoBlue 130 PS (96 kW) HDT Euro6	3.31/3.73	tbc	tbc	tbc	tbc
2.0 TDCi Ford EcoBlue 170 PS (125 kW)	3.31/3.73	169	7.3	6.0	6.5
2.0 TDCi Ford EcoBlue 170 PS (125 kW)	4.10	194-201	9.2	6.3-6.7	7.4-7.7
2.0 TDCi Ford EcoBlue 170 PS (125 kW) HDT Euro6	3.31/3.73	tbc	tbc	tbc	tbc
2.0 TDCi Ford EcoBlue 185 PS (136 kW)	3.31/3.73	169	7.3	6.0	6.5
2.0 TDCi Ford EcoBlue 185 PS (136 kW)	4.10	201	9.2	6.7	7.7
AWD					
2.0 TDCi Ford EcoBlue 130 PS (96 kW)/170 PS (125 kW)	4.10	245	11.1	8.3	9.3

Note for all Stage VI engines: Values shown illustrate vehicles fitted with Auto Start-Stop. Auto Start-Stop system reduces CO₂ emissions and fuel consumption by 6 g/km and between 0.2-0.3 L/100 km respectively. ⁰⁰⁰The illustrated axle ratio shown is the one available dependent upon model, GVM payload and engine/transmission combination. ⁰⁰⁰The declared fuel/energy consumptions and CO₂ emissions for Stage 6c (NI) and Stage 6d-TEMP (MI) engines are measured according to the technical requirements and specifications of European regulations (EC) 715/2007, (EC) 692/2008 and (EU) 2017/1151, as last amended. Fuel consumption and CO₂ emissions may be specified for a vehicle variant and not for a single vehicle. The applied standard test procedure enables a comparison between different vehicle types and different manufacturers. In addition to the fuel efficiency of a vehicle; driving behaviour as well as other non-technical factors are very important in determining a vehicle's fuel/energy consumption and CO₂ emissions. A guide on fuel economy and CO₂ emissions which contains data for all new passenger carrying vehicle models is available at any point of sale free of charge or can be downloaded at ford.co.uk

Model availability

	350 L2	350 L3	350 L4	350 L5	470 L2	470 L3	470 L4	470 L5
Single Cab Chassis								
FWD								
2.0 TDCi Ford EcoBlue 105 PS (77 kW)	●	-	-	-	-	-	-	-
2.0 TDCi Ford EcoBlue 130 PS (96 kW)	●	●	●	-	-	-	-	-
2.0 TDCi Ford EcoBlue 130 PS (96 kW) 6-speed automatic	●	●	●	-	-	-	-	-
2.0 TDCi Ford EcoBlue 170 PS (125 kW)	-	●	●	-	-	-	-	-
RWD								
2.0 TDCi Ford EcoBlue 130 PS (96 kW)	●	●	●	●	●	●	-	-
2.0 TDCi Ford EcoBlue 170 PS (125 kW)	●	●	●	●	●	●	●	●
2.0 TDCi Ford EcoBlue 170 PS (125 kW) Stage 6 HDT	-	-	●	-	-	-	-	-
AWD								
2.0 TDCi Ford EcoBlue 130 PS (96 kW)	●	●	-	-	-	-	-	-
Double Cab Chassis								
FWD								
2.0 TDCi Ford EcoBlue 130 PS (96 kW)	-	●	-	-	-	-	-	-
2.0 TDCi Ford EcoBlue 170 PS (125 kW)	-	●	-	-	-	-	-	-
RWD								
2.0 TDCi Ford EcoBlue 130 PS (96 kW)	-	●	●	●	-	-	-	-
2.0 TDCi Ford EcoBlue 170 PS (125 kW)	-	●	●	●	-	●	●	●
2.0 TDCi Ford EcoBlue 185 PS (136 kW)	-	●	-	-	-	-	-	-
AWD								
2.0 TDCi Ford EcoBlue 130 PS (96 kW)	-	●	-	-	-	-	-	-
Skeletal Chassis								
FWD								
2.0 TDCi Ford EcoBlue 130 PS (96 kW)	●	●	●	-	-	-	-	-
2.0 TDCi Ford EcoBlue 130 PS (96 kW) 6-speed automatic	●	●	●	-	-	-	-	-
2.0 TDCi Ford EcoBlue 170 PS (125 kW)	●	●	●	-	-	-	-	-
2.0 TDCi Ford EcoBlue 170 PS (125 kW) 6-speed automatic	●	●	●	-	-	-	-	-

Note: ● = Available, - = Not available. **FWD** = Front-wheel drive, **RWD** = Rear-wheel drive, **AWD** = All-wheel drive, **L1** = Short wheelbase, **L2** = Medium wheelbase, **L3** = Long wheelbase, **L4** = Long wheelbase with extended frame, **L5** = Extra long wheelbase with extended frame. All engines are EU6.2 unless stated otherwise. *Available from February 2020 production.

WWW



Full features and specifications (not located in the printed brochure)

To review the full features and specifications, download the digital ebrochure or view the interactive brochure. These can be downloaded from: www.ford.co.uk or scan the QR code.

Get the most from your new Ford

We want to help you get the most from your new Ford. And to do that, you need to know how much it is designed to safely carry, both in terms of payload and load volume. Your Transit Centre can provide professional advice on important specification aspects, and help to find the right van for your budget and business needs.

The Ford Transit is designed to carry cargo – and lots of it.

Choosing a new vehicle is an important decision with lots of factors to be considered. While some aspects, like selecting the most appropriate derivative, identifying the intended primary use and determining load box size are relatively simple, others, such as calculating payload are more complex.

Payload capacity

To calculate payload, you need to know two things: the vehicle's gross vehicle mass (GVM) and its kerb mass.

GVM is the maximum permissible weight of the vehicle when loaded and ready to go – that includes the weight of the vehicle itself, ancillaries, driver and crew (assuming the industry standard weight of 75 kg/person), fluids, fuel tank 90% full (1 litre of diesel = approximately 0.85 kg), optional and aftermarket equipment, and cargo.

For simplicity, Ford Transit models are designated according to their GVM. For example, a 280 has a GVM of c. 2,800 kg; and a 300 has a GVM of c. 3,000 kg.

Kerb mass is the weight of a standard-specification Ambiente series vehicle, including fluids and fuel tank 90% full, but without the driver, crew or cargo.

Payload is the difference between the two.

Gross vehicle mass minus **kerb mass** = **payload**

So to help you choose the right vehicle for your needs, here are some more detailed explanations about the factors that can influence a vehicle's payload. These include, but are not limited to:

Driver and crew

We calculate the weight of the driver and crew based on the industry-standard weight of 75 kg/person. Remember that the driver and crew are not included in the kerb mass figure, so when a driver or crew boards the vehicle, its payload will be reduced accordingly.

Factory-fitted options

Most factory-fitted options will affect a vehicle's payload. For example, air conditioning can add approximately 18 kg to a vehicle's weight, and therefore reduce its payload accordingly.

However, specifying a single front passenger seat in lieu of the standard dual seat will reduce the vehicle's weight by approximately 12 kg, and increase its payload by the same amount. Your Transit Centre will be able to tell you what features can add or reduce your vehicle's kerb mass and by how much.

Series

All kerb masses quoted in this brochure are for standard-specification Ambiente series models, unless otherwise stated. Trend series models will generally weigh more than Ambiente series due to the increased level of features and equipment.

Manufacturing tolerances

Variations in manufacturing and production processes mean that no two vehicles are likely to weigh exactly the same.

Accessories and aftermarket conversions

It is important to think carefully about what you add to your vehicle after you take delivery. Any accessories fitted or aftermarket conversions to the vehicle may adversely affect its payload. Please speak to your Transit Centre for more information and advice.

If payload is critical to your business, or if you plan to carry cargo at, or close to, the vehicle's maximum capacity, your Transit Centre can help. Using their specialist expertise and knowledge, they can advise you on the exact specification of vehicle required to meet your individual business needs.

Configure your vehicle to suit your job

Ford Commercial Vehicles are available with a wide range of standard and optional features. Your Transit Centre can help you ensure that you specify the right vehicle features for your specific business needs, including technical items to aid aftermarket fitment of specialist equipment or conversion.

Note Technical information for vehicle converters can be found online via the Body and Equipment Mounting Manual @etis.ford.com go to >information >>vehicle conversions.

Weights and loads

	Max. gross payload (excluding driver) (kg)	Gross vehicle mass (kg)	Min. kerb mass* (excluding driver) (kg)	Front axle plated mass (kg)	Rear axle plated mass (kg)
Single Cab Chassis (3 seats)					
FWD					
350 L2	1757-1802	3500	1698-1744	1750	2150
350 L3	1738-1783	3500	1718-1763	1750	2250
350 L4	1721-1766	3500	1735-1780	1750	2250
RWD					
350 L2	1705-1723	3500	1778-1795	1750	2150
350 L3	1683-1701	3500	1800-1817	1750	2250
350 L4	1666-1684	3500	1817-1834	1750	2250
350 L5	1470-1638	3500	1863-2030	1850	2250/2450
470 L2	2755	4700	1945	1850	3300
470 L3	2733	4700	1967	1850	3300
470 L4	2716	4700	1984	1850	3300
470 L5	2670	4700	2030	1850	3300
AWD					
350 L2	1617	3500	1883	1850	2150
350 L3	1595	3500	1905	1850	2250
Double Cab Chassis (7 seats)					
FWD					
350 L3	1619-1620	3500	1881	1750	2250
RWD					
350 L3	1520-1538	3500	1963-1980	1750	2250
350 L4	1503-1521	3500	1980-1997	1750	2250
350 L5	1447-1465	3500	2036-2053	1850	2250
470 L3	2570	4700	2130	1850	3300
470 L4	2553	4700	2147	1850	3300
470 L5	2497	4700	2203	1850	3300
AWD					
350 L3	1432	3500	2068	1850	2250
Double Cab Chassis (7 seats) DRW					
RWD					
350 L3	1370	3500	2130	1850	2450
350 L4	1353	3500	2147	1850	2450
350 L5	1297	3500	2203	1850	2450
Skeletal Chassis (2 seats)					
350 L2	1800-1845	3500	1655-1700	1750/1850	2150
350 L3	1782-1827	3500	1673-1718	1750/1850	2250
350 L4	1761-1806	3500	1694-1739	1750/1850	2250

FWD = Front-wheel drive, **RWD** = Rear-wheel drive, **AWD** = All-wheel drive, **L1** = Short wheelbase, **L2** = Medium wheelbase, **L3** = Long wheelbase, **L4** = Long wheelbase extended length, **L5** = Extra-long wheelbase, **SRW** = Single rear wheels, **DRW** = Dual rear wheels. Figures apply to EU6.2 LDTIII Chassis Cabs with Auto Start-Stop unless otherwise stated. ***Kerb mass** is affected by many factors such as bodystyles, engines and options. It is the weight of a standard-specification base vehicle (different series will have different kerb masses), including fluids and fuel tank 90% full, but without the driver (75 kg), crew or cargo. Payload within this guide is the difference between gross vehicle mass (GVM) and kerb mass with a further 75 kg deduction for the weight of the driver. It must be noted that actual weight will always be subject to manufacturing tolerances which may result in payload variations between this guide and actual weight. For customers intending to load vehicle close to maximum payload, we suggest you also add a margin for error of 5% of kerb mass to the kerb mass figure before calculation, to reduce risk of overloading. NB: It is the responsibility of the vehicle operator to ensure their vehicles are legally compliant for road use. For rear float option vehicles, kerb mass is increased and payload reduced.

Weights and loads

	Max. gross payload (excluding driver) (kg)	Gross vehicle mass (kg)	Min. kerb mass* (excluding driver) (kg)	Front axle plated mass (kg)	Rear axle plated mass (kg)
Single Cab with float (3 seats)					
FWD					
350 L2	1399-1444	3500	2101-2056	1750	2150
350 L3	1269-1387	3500	2112-2157	1750	2250
350 L4	1284-1329	3500	2171-2216	1750	2250
RWD					
350 L2	1347-1364	3500	2136-2153	1750/1850	2150
350 L3	1289-1306	3500	2211-2194	1750/1850	2250
350 L4	1230-1247	3500	2253-2270	1750/1850	2250
350 L5	1100-1117	3500	2383-2400	1850	2250
470 L2	2391	4700	2309	1850	3300
470 L3	2334	4700	2366	1850	3300
470 L4	2266	4700	2434	1850	3300
470 L5	2134	4700	2566	1850	3300
AWD					
350 L2	1259	3500	2241	1850	2150
350 L3	1201	3500	2299	1850	2250
Double Cab with float (7 seats)					
FWD					
350 L3	1284	3500	2216	1750	2250
RWD					
350 L3	1185-1202	3500	2298-2315	1750/1850	2250
350 L4	1143-1160	3500	2340-2357	1750/1850	2250
470 L3	2235	4700	2465	1850	3300
470 L4	2193	4700	2507	1850	3300
AWD					
350 L3	1097	3500	2403	1850	2250

FWD = Front-wheel drive, **RWD** = Rear-wheel drive, **AWD** = All-wheel drive, **L1** = Short wheelbase, **L2** = Medium wheelbase, **L3** = Long wheelbase, **L4** = Long wheelbase extended length, **L5** = Extra-long wheelbase, **SRW** = Single rear wheels, **DRW** = Dual rear wheels. Figures apply to EU6.2 LDTIII Chassis Cabs with Auto Start-Stop unless otherwise stated. *Kerb mass is affected by many factors such as bodystyles, engines and options. It is the weight of a standard-specification base vehicle (different series will have different kerb masses), including fluids and fuel tank 90% full, but without the driver (75 kg), crew or cargo. Payload within this guide is the difference between gross vehicle mass (GVM) and kerb mass with a further 75 kg deduction for the weight of the driver. It must be noted that actual weight will always be subject to manufacturing tolerances which may result in payload variations between this guide and actual weight. For customers intending to load vehicle close to maximum payload, we suggest you also add a margin for error of 5% of kerb mass to the kerb mass figure before calculation, to reduce risk of overloading. NB: It is the responsibility of the vehicle operator to ensure their vehicles are legally compliant for road use. For rear float option vehicles, kerb mass is increased and payload reduced.

Max. GTM* (kg)

	Axle ratio [®]	GVM	
		350	470
Single/Double Cab Chassis			
FWD			
2.0 TDCi Ford EcoBlue 105 PS (77 kW)	4.429	5065	–
2.0 TDCi Ford EcoBlue 130 PS (96 kW)	4.429	5065/5265	–
2.0 TDCi Ford EcoBlue 130 PS (96 kW)	4.93	5700	–
2.0 TDCi Ford EcoBlue 130 PS (96 kW) 6-speed automatic	3.39	4250	–
2.0 TDCi Ford EcoBlue 170 PS (125 kW)	4.429	5065/5265	–
2.0 TDCi Ford EcoBlue 170 PS (125 kW)	4.93/3.450	6000	–
RWD			
2.0 TDCi Ford EcoBlue 130 PS (96 kW)	4.10	–	6500
2.0 TDCi Ford EcoBlue 130 PS (96 kW)	3.31	5500/5550 /6000	–
2.0 TDCi Ford EcoBlue 130 PS (96 kW)	4.10	6500	–
2.0 TDCi Ford EcoBlue 130 PS (96 kW) HDT Euro 6	4.10	–	6500
2.0 TDCi Ford EcoBlue 170 PS (125 kW)	3.31	5650/6000	–
2.0 TDCi Ford EcoBlue 170 PS (125 kW)	4.10	–	7000
2.0 TDCi Ford EcoBlue 170 PS (125 kW)	4.10	7000	–
2.0 TDCi Ford EcoBlue 170 PS (125 kW) HDT Euro 6	3.31	5500	–
2.0 TDCi Ford EcoBlue 185 PS (136 kW)	3.31	5650	–
2.0 TDCi Ford EcoBlue 185 PS (136 kW)	4.10	7000	–
AWD			
2.0 TDCi Ford EcoBlue 130 PS (96 kW) Stage VI	4.10	6000	–

● = Standard, ○ = Option, at extra cost. **Note:** All engines are EU6.2 unless stated otherwise. [®]The illustrated axle ratio shown is the one available dependent upon model, GVM payload and engine combination. *GTM is limited to 5,500 kg if fitted with rear air conditioning. Consult your Dealer for more information. **Available from February 2020 production.

Max. braked trailer plate (kg)(a)

	Axle ratio ⁸⁸	GVM	
		350	470
Single/Double Cab Chassis (without float)			
FWD			
2.0 TDCi Ford EcoBlue 105 PS (77 kW)	4.43	2500	–
2.0 TDCi Ford EcoBlue 130 PS (96 kW)	4.43	2500	–
2.0 TDCi Ford EcoBlue 130 PS (96 kW)	4.93	2800	–
2.0 TDCi Ford EcoBlue 130 PS (96 kW) 6-speed automatic	3.39	1850/1950	–
2.0 TDCi Ford EcoBlue 170 PS (125 kW)	4.43	2500/2600	–
2.0 TDCi Ford EcoBlue 170 PS (125 kW)	4.93	2800	–
RWD			
2.0 TDCi Ford EcoBlue 130 PS (96 kW)	3.31	2750/2800	–
2.0 TDCi Ford EcoBlue 130 PS (96 kW)	4.10	3000	–
2.0 TDCi Ford EcoBlue 130 PS (96 kW)	4.10	–	2300
2.0 TDCi Ford EcoBlue 170 PS (125 kW) HDT Euro 6	3.31	2800	–
2.0 TDCi Ford EcoBlue 170 PS (125 kW)	3.31	2800	–
2.0 TDCi Ford EcoBlue 170 PS (125 kW)	4.10	3500	–
2.0 TDCi Ford EcoBlue 170 PS (125 kW)	4.10	–	3500
2.0 TDCi Ford EcoBlue 185 PS (136 kW)	3.31	2800	–
2.0 TDCi Ford EcoBlue 185 PS (136 kW)	4.10	3500	–
AWD			
2.0 TDCi Ford EcoBlue 130 PS (96 kW)	4.10	2800	–

● = Standard, ○ = Option, at extra cost.
Note: All engines are EU6.2 unless stated. ^(a)Max. braked trailer mass is dependent on chosen engine power and dependent on the additional options/equipment selected. ⁸⁸The illustrated axle ratio shown is the one available dependent upon model, GVM payload and engine combination.
*Available from February 2020 production.

Max. braked trailer plate (kg)(a)

	Axle ratio ⁸⁸	GVM	
		350	470
Single/Double Cab Chassis (with float)			
FWD			
2.0 TDCi Ford EcoBlue 105 PS (77 kW)	4.43	2500	–
2.0 TDCi Ford EcoBlue 130 PS (96 kW)	4.43	2500/2600	–
2.0 TDCi Ford EcoBlue 130 PS (96 kW)	4.93	2800	–
2.0 TDCi Ford EcoBlue 130 PS (96 kW) 6-speed automatic	3.39	1800-1900	–
2.0 TDCi Ford EcoBlue 170 PS (125 kW)	4.43	2500/2600	–
2.0 TDCi Ford EcoBlue 170 PS (125 kW)	4.93	2800	–
RWD			
2.0 TDCi Ford EcoBlue 130 PS (96 kW)	4.10	–	2300
2.0 TDCi Ford EcoBlue 130 PS (96 kW)	3.31	2750/2800	–
2.0 TDCi Ford EcoBlue 130 PS (96 kW)	4.10	3000	–
2.0 TDCi Ford EcoBlue 170 PS (125 kW)	3.31	2800	–
2.0 TDCi Ford EcoBlue 170 PS (125 kW)	4.10	3500	–
2.0 TDCi Ford EcoBlue 170 PS (125 kW) HDT Euro 6	4.10	–	3500
2.0 TDCi Ford EcoBlue 185 PS (136 kW)	3.31	2800	–
2.0 TDCi Ford EcoBlue 185 PS (136 kW)	4.10	3500	–
AWD			
2.0 TDCi Ford EcoBlue 130 PS (96 kW)	4.10	2800	–

● = Standard, ○ = Option, at extra cost.
Note: All engines are EU6.2 unless stated. ^(a)Max. braked trailer mass is dependent on chosen engine power and dependent on the additional options/equipment selected. ⁸⁸The illustrated axle ratio shown is the one available dependent upon model, GVM payload and engine combination.
*Available from February 2020 production.

Styling and appearance

Wheels		Leader	Skeletal Chassis (Leader)
Steel – 16x6½" (fitted with 235/65 R16C tyres on all series, 215/65 R16C on L2 (MWB) 310 series)	● /–	●	●
Steel – 16"x5", dual rear wheels, hub caps on front wheels (fitted with 195/75 R16C BSW tyres)* (standard with dual rear wheels)	□	–	–
Wheel covers – Half caps	●	–	–
Wheel covers – Full (not available with DRW models)	–	●	●
Spare – Full-size steel with tool kit (standard on DRW)	○	●	●
Tyre inflator kit	●	□	□
Design features			
Door mirrors – Blind spot eliminator and integrated side indicator	●	●	●
Door mirrors – Manual adjust, short arm	●	●	●
Door mirrors – Electrically-operated and heated, short arm	○	○	○
Door mirrors – Electrically-operated and heated, long arm	○	○	○
Door mirrors – Power-foldable, electrically-operated and heated, short arm	○	○	○
Body – H1 (Low Roof)	●	●	●
Anodised aluminium side float, wide – Side under-run rails (where legally required), tailboard support straps, mesh headboard second unit and side, and rear marker lights without posts (not available on L1 (SWB) models)	○	–	–
Premium aluminium (body colour) dropside float, wide – Side under-run rails (where legally required), tailboard support straps, mesh headboard second unit and side, and rear marker lights with posts (not available on L1 (SWB) models)	○	–	–
Bodyside mouldings – Wide, self colour	●	●	●
Front bumper – Partial body colour	●	●	●
Front grille – Self colour	●	●	●
Mudflaps – Front	○	○	○
Tinted glass – Complete	●	●	●
Paint			
Paint – Metallic	○	○	○
Option Packs			
Visibility Pack 1 – Quickclear heated windscreen, low washer fluid sensor, and electrically-operated and heated door mirrors	○	–	–
Visibility Pack 4 – Quickclear heated windscreen, low washer fluid sensor, power-foldable electrically-operated and heated door mirrors, automatic headlights, autowipers, front fog lights, and variable cluster dimming	○	○	○

● = Standard, ○ = Option, at extra cost, □ = Part of an option pack, at extra cost.
*The wheel you choose will be fitted with the tyre size noted, but no choice of tyre brand is available.

Driving experience

	Leader	Skeletal Chassis (Leader)
Driver assistance		
Cruise control (includes leather-trimmed steering wheel and Adjustable Speed Limiter)	<input type="radio"/>	<input type="radio"/>
Lane-Keeping Alert ²⁾ (includes auto high beam ¹⁾ , high-series instrument cluster, Quickclear heated windscreen and automatic headlights)	<input type="radio"/>	<input type="radio"/>
Lane-Keeping Aid ²⁾ (includes Lane-Keeping Alert)	<input type="radio"/>	<input type="radio"/>
Adaptive Cruise Control (ACC) (includes Pre-Collision Assist ²⁾ (with Pedestrian Protection), leather-trimmed steering wheel and Lane-Keeping Alert ²⁾ (when EU6.2 engine is present)	<input type="radio"/>	<input type="radio"/>
Intelligent Adaptive Cruise Control (includes Pre-Collision Assist ²⁾ and leather-trimmed steering wheel) (only available when specified with ICE Pack 25)	<input type="checkbox"/>	<input type="checkbox"/>
Acceleration Control	<input type="radio"/>	<input type="radio"/>
Speed Limiter – 56 mph (90 km/h) (optional on Single Cab and Double Cab 350 series)	<input checked="" type="radio"/>	–
Speed Limiter – 62 mph (100 km/h)	<input type="radio"/> / <input type="checkbox"/>	<input type="radio"/>
Speed Limiter – 70 mph (110 km/h)	<input type="radio"/> / <input type="checkbox"/>	<input type="radio"/>
Speed Limiter – 97 mph (155 km/h)	<input checked="" type="radio"/>	<input checked="" type="radio"/>
Trailer Sway Control (TSC) ¹⁾ (activated with Ford trailer tow attachments)	<input type="checkbox"/>	–
Exterior lighting		
Headlights – Daytime running lights	<input checked="" type="radio"/>	<input checked="" type="radio"/>
Headlights – Halogen projector headlights containing daytime running lights	<input checked="" type="radio"/>	<input checked="" type="radio"/>
Headlights – Static cornering	<input type="checkbox"/>	<input type="checkbox"/>
Headlights – Bi-xenon headlights with LED daytime running lights and static bending	<input type="radio"/>	<input type="radio"/>
Headlights – Levelling control	<input checked="" type="radio"/>	<input checked="" type="radio"/>
Headlights – Automatic on/off	<input type="checkbox"/>	<input type="checkbox"/>
Headlights – Quad beam	<input checked="" type="radio"/>	<input checked="" type="radio"/>
Fog lights – Front	<input type="radio"/> / <input type="checkbox"/>	<input type="checkbox"/>
Roof marker lights	<input checked="" type="radio"/>	–
Side marker lights (standard on Leader and Trend Skeletal 350EL, on Camper 350EL, 430EL, 430E, on Single Chassis on 350E, 430E, 470E and on Double Chassis 350M)	<input checked="" type="radio"/>	<input checked="" type="radio"/>
Suspension		
Front, independent MacPherson struts, variable rate coil springs, stabiliser bar, gas-pressurised shock absorbers and rear leaf springs	<input checked="" type="radio"/>	<input checked="" type="radio"/>
Instrument and controls		
Tyre Pressure Monitoring System (TPMS) ¹⁾	<input type="radio"/>	<input type="radio"/>
Tachograph – Digital, electronic, 24-hour (not available on Single Chassis and Double Chassis with 310, 330, 370, 410, 440, 460 GVM and 4WD)	<input type="radio"/>	<input type="checkbox"/>
Technology		
Selectable driving mode	<input checked="" type="radio"/>	<input checked="" type="radio"/>

= Standard, = Option, at extra cost, = Part of an option pack, at extra cost. ¹⁾Safety feature, ²⁾Driver assistance feature.

Performance and efficiency

	Leader	Skeletal Chassis (Leader)
Instruments and controls		
Trip computer (distance to empty, instant and average fuel consumption, average speed, outside temperature)	<input checked="" type="radio"/>	<input checked="" type="radio"/>
Water in fuel filter sensor	<input checked="" type="radio"/>	<input checked="" type="radio"/>
Battery – Cold start (-20°C)	<input checked="" type="radio"/>	<input checked="" type="radio"/>
Battery – Twin Improved Flooded (IF), cold start (-29°C)	<input type="radio"/>	<input type="radio"/>
Battery – Twin H8 AGM deep cycle battery (EU6.2 engine variants only) (requires twin heavy-duty battery layout)	<input type="radio"/>	<input type="radio"/>
Alternator – Standard duty 165 Amp (EU6.2 engines)	<input checked="" type="radio"/>	–
Alternator – Extra heavy-duty (240 Amp)	–	<input checked="" type="radio"/>
Technology		
Coated diesel particulate filter (cDPF)	<input checked="" type="radio"/>	<input checked="" type="radio"/>

= Standard, = Option, at extra cost.

Comfort and convenience

	Leader	Skeletal Chassis (Leader)
Interior convenience		
Bottle holder – Twin, 2-litre bottle capacity, facia-mounted	●	●
Glovebox – With lid and A4 file storage capability	●	●
AUX 2-DIN instrument panel console	○	○
MyKey	●	●
Power point socket – 2 x 12 V (located on instrument panel and in stowage bin)	●	●
Power point socket – 230 V (400 W) (excludes HEVI)	○	–
Smokers' Pack – Cigar lighter and ash cup	○	○
Storage – Front door map pockets	●	●
Storage – Driver's side, storage compartment on facia top	●	●
Storage – Underseat stowage compartment (under dual passenger seat)	●	●
Audio and communication systems		
Single DIN AM/FM Radio with DAB, MyFord Dock, four front speakers (two woofers and two tweeters), remote audio controls, Bluetooth® and a USB connectivity port with iPod® functionality (standard on Single Cab with short wheelbase and 350 series, on Double Cab 350 series, not available on Skeletal Trend on 350EL, standard on Camper for 350 series except 350EL)	●	○
Connection Radio with DAB (includes Emergency Assistance*), with four front speakers (two woofers and two tweeters), 4" TFT display, remote audio controls, FordPass Connect modem, GNSS antenna (fin antenna), Bluetooth® and two USB connectivity ports with iPod® functionality (optional on Single Cab, Double Cab, Camper Chassis 350 series and short wheelbase Single Cab)	● / ○	○
AM/FM Radio with DAB, Ford SYNC 2.5 (includes Emergency Assistance*) with Bluetooth®, Voice Passthrough, AppLink, audible text messaging and privacy mode, 8" touchscreen display, integrated control panel, FordPass Connect modem, GNSS antenna (fin antenna), two USB connectivity ports with iPod® functionality, four front speakers (two woofers and two tweeters)	○	○
AM/FM Radio with DAB, embedded navigation, Ford SYNC 3 (includes Emergency Assistance*) with Bluetooth®, Voice Control System, AppLink, audible text messaging and privacy mode, 8" touchscreen display, extended integrated control panel, FordPass Connect modem, GNSS antenna (fin antenna), two USB connectivity ports with iPod® functionality, remote audio controls, six speakers	○	○
AM/FM Radio with DAB, embedded navigation, Intelligent Adaptive Cruise Control, Ford SYNC 3 (includes Emergency Assistance*) with Bluetooth®, Voice Control System, AppLink, audible text messaging and privacy mode, 8" touchscreen display, extended integrated control panel, FordPass Connect modem, GNSS antenna (fin antenna), two USB connectivity ports with iPod® functionality, remote audio controls, six speakers (not available on AWD)	○	○

Comfort and convenience

	Leader	Skeletal Chassis (Leader)
Climate control		
Air conditioning – Front, including filter-air pollen purifier	○	○
Heater – Recirculation	●	●
Interior lighting		
Courtesy lights – Header-mounted, front with theatre dimming	●	●
Seating		
Driver's seat – 8-way (fore/aft; recline; height; and tilt) with armrest	●	●
Front passenger's seat – Single, 4-way (fore/aft; and recline)	○	–
Front passenger's seat – Single, 4-way heated (fore/aft; and recline)	○	–
Front passenger's seat – Dual, fixed back with split lift-up seat cushion for stowage, fold-out table	●	○
Front passenger's seat – Dual, heated, fixed back with split lift-up seat cushion for stowage, fold-out table	○	–
Front passenger's seat – 2-way manual seat adjuster	●	○
Rear seats – Second row; quad seats (2+2) (Chassis Double Cab only)	●	–
Rear Seat Pack 1 – Second row; removable quad seats (2+2) (Double Cab only)	●	–
Instruments and controls		
Hydraulic power-assisted steering (HPAS) (only available with AWD, not available on EU6.2 engine variants)	●	●
Electric power-assisted steering (EPAS) (standard on EU6.2 engine 2WD variants and all HDT6 engines)	●	●
Steering column – Rake- and reach-adjustable	●	●
Wipers – Front, variable/intermittent with electric wash	●	●
Wipers – Front, automatic with rain sensor (includes automatic headlights)	□	□
Steering wheel – 4-spoke, polyurethane	●	●
Steering wheel – 4-spoke, leather-trimmed	□	□
Windows – Electrically-operated front with one-touch lowering on driver's side	●	●
Technology		
Single fuel tank – 70 litres	●	●
Ford Easy Fuel capless refuelling system with misfuel inhibit	●	●
AdBlue® aftertreatment system – 24 litre	●	●
Auto Start-Stop system	●	●
Quickclear heated windscreen	□	□

● = Standard, ○ = Option, at extra cost, □ = Part of an option pack, at extra cost.

*Ford Emergency Assistance is an innovative SYNC feature that uses a Bluetooth®-paired and connected mobile phone to help vehicle occupants initiate a direct call to the local Communications Centre, following a vehicle crash event involving an airbag deployment or fuel pump shut off. The feature operates in more than 40 European countries and regions. **Note:** The Bluetooth® trademark and logos are owned by the Bluetooth SIG, Inc. and any use of such marks by Ford Motor Company Limited is under licence. Other trademarks and trade names are those of their respective owners.

Safety and security

	Leader	Skeletal Chassis (Leader)
Safety		
Anti-lock braking system (ABS)	●	●
Electronic Stability Control (ESC) ¹⁾	●	●
Curve Control ¹⁾	●	●
Hill Start Assist (HSA) ²⁾	●	●
Load Adaptive Control (LAC) ¹⁾	●	●
Emergency Brake Assist (EBA) ¹⁾	●	●
Roll Stability Control (RSC) ¹⁾	●	●
Airbag – Driver's ¹⁾	●	●
Airbag – Front passenger's* ¹⁾ (including passenger's airbag deactivation switch)	○/□	○
Airbag – Front side and curtain airbags ¹⁾	□	–
Seat belts – 3-point diagonal inertia reel (all seats) ¹⁾	●	●
First aid kit	○	○
Security		
Alarm – Perimeter	○	○
Alarm – Thatcham Category 1 – Cab interior sensing, inclination sensor and trailer coupling, when fitted (includes remote locking with 2 key fobs)	○	–
Immobiliser – Safeguard Passive Anti-Theft System (PATS) (insurance-approved Category 2 immobiliser)	●	●
Locks – Power central locking	○	●
Locks – Power door deadlocks, shielded with strengthened mountings	●	–
Locks – Remote control central locking with 1 key fob	●	–
Locks – Remote control central locking with 2 key fobs (included in Alarm - Thatcham Category 1)	○/□	●
Locks – Configurable unlocking – 2-stage unlocking*	●	●
Locks – Configurable unlocking – Independent driver's door unlocking*	○	–
Locks – Configurable unlocking – Courier unlocking with auto slam lock, zonal opposite door relocking and 3 second auto relocking*	○	–
Locks – Auto re-locking, doors relock after 45 seconds if no door is opened	●	●
Locks – Audio mis-lock feedback, audible signal if a door is ajar when locking activated	●	●
Locks – Audio mis-lock feedback, audible signal if a door is ajar when locking activated, with slam lock	○	–
Locks – Auto locking on drive-away, doors automatically lock at 8 km/h (5 mph)	●	●
Locks – Key-operated bonnet release	●	●
Brakes		
Dual-circuit front and rear discs, with self-adjusting servo-assistance and ABS	●	●

● = Standard, ○ = Option, at extra cost, □ = Part of an option pack, at extra cost. ¹⁾Safety feature, ²⁾Driver assistance feature. *For details of the configurations available please consult your Ford Dealer. Please note: Configurable locking must be defined at the time of order, it cannot be ordered as a Dealer-fitted option or accessory. ***Note: A rear-facing child seat should never be placed in the front passenger seat when the Ford vehicle is equipped with an operational front passenger's airbag.**

Utility

	Leader	Skeletal Chassis (Leader)
Body		
Side windows – Second row, fixed (Double Chassis Cab only)	●	–
Engine undershield	○	○
Carpet and trim		
Floor covering – Cab, easy-clean rubber (Chassis Single Cab only)	●	●
Floor covering – Extended, easy-clean rubber (Chassis Double Cab only)	●	–
Headlining – Cab, moulded (Chassis Single Cab only)	●	●
Headlining – Extended, moulded (Double Chassis Cab only)	●	–
Certification		
Vehicle Identification Number – Visible	●	●
Exterior functional		
Tow bar with Trailer Sway Control and 13-pin electrics (tachograph may be required)	○	–
Instruments and control		
Gearshift Indicator light	●	●

● = Standard, ○ = Option, at extra cost, □ = Part of an option pack, at extra cost.

Special Vehicle Options

	SVO code	Leader	Skeletal Chassis (Leader)
Body			
Omit passenger seat (no pedestal) (available on Single Chassis Cab)	A304	○	-
Seat Pack 3 - Orange Seat Belts – Single Passenger Seat	A305	○	-
Seat Pack 4 - Orange Seat Belts – Dual Passenger Seat	A306	○	-
Seat Pack 5 - Orange Seat Belts – Delete Passenger Seat (available on Single Chassis Cab)	A307	○	-
L2 & L3 wheelbases with 4 side marker lights	A560	○	-
L4 wheelbase with 6 side marker lights	A560	○	-
Double Cab Utility Area (RWD and FWD Models) Delete rear crew seat and windowless rear crew doors. (Does not include bulkhead or flooring which if required can be provided by a convertor at extra charge)	A989	-	○
Electrical			
Engine rpm speed control, 1300–3000 rpm (manual transmission only, available on Skeletal Chassis only as part of A550)	A003	○/□	□
Single AGM deep cycle battery H8 95Ah (includes standard battery) (not available when specified with 230V 400W 3-pin power converter)	A739	○/□	○/□
Auxiliary fuse panel (included in Beacon Preparation Pack)	A526	○/□	○/□
Beacon Preparation Pack – Switch and wiring (includes auxiliary fuse panel (A526))	A606	○/□	-
High specification interface connector (provides a range of hardwired signals and power for converters (includes auxiliary fuse panel (A526))	A608	○	○
The Ford Programmable Battery Guard – Patented 10 – mode programmable battery guard system capable of protecting Ford and third party battery (not available when specified with 230V 400W 3-pin power converter; included in A550)	A540	○/□	○/□
Convertor – High-Power Supply System – Meets heavy power-take-off requirements by equipping vehicles with two high performance deep cycle AGM batteries (2 x 95 Ah), 240 A alternator, engine rpm speed control and the Ford Programmable Battery Guard (not available with automatic transmission and not available when specified with 230V 400W 3-pin power converter)	A550	○	○
Paint			
Special paint, 100 colours available, consult Dealer for details*	Various	○	○

○ = Option, at extra cost.

*SVO paint suffix must be entered at time of ordering. SVO paint pulls self-colour (black) bumpers, bodyside mouldings, mirror housings and door handles.

Next steps



For full features and specifications, download the digital ebrochure or view the interactive brochure to benefit from the full immersive experience of your chosen Ford model. Please download them from: www.ford.co.uk



test drive

Visit your Ford Commercial Vehicle Dealer and test drive the Ford Transit for yourself. Find your local Ford Commercial Vehicle Dealer: www.ford.co.uk



build

Build and price your new Ford Transit to your exact specification and see how it looks at www.ford.co.uk



contact

Ford Credit Account Services : 0345 712 5490

Ford Lease Customer Services : 0344 600 1405

Calls to 0344 and 0345 numbers are charged at the same rate as a standard 01 or 02 geographic number, even when calling from a mobile.



own

When you drive away in your new vehicle, we're with you all the way. Ford has a large authorised service network to help you keep your vehicle in the best condition. And should your new Ford ever require accident repair, a Ford Accident Repair Centre is the best place to get your vehicle back to its pre-accident condition and on the road as quickly as possible.



finance

When it comes to financing your Ford commercial vehicle, our size and expertise means we're well placed to provide you with a wide range of finance plans.

Ford Credit* provides a range of finance plans for your commercial vehicle customers interested in vehicle ownership.

Ford Lease^ specialises in contract hire and leasing and provides an alternative range of finance plans which can be tailored to suit your business.

For more information about our finance products visit ford.co.uk

*Finance subject to status. Guarantees may be required. Freepost Ford Credit.

Ford Credit is a trading style of FCE Bank plc. Which is authorised by the Prudential Regulation Authority and regulated by the Financial Conduct Authority and the Prudential Regulation Authority under firm reference number 204469.

^Ford Lease is provided by ALD Automotive Limited acting as Ford Lease BS16 7LB. ALD is registered in England No. 987418. ALD is authorised and regulated by the Financial Conduct Authority.



FordPass i is a new platform that will empower you to rethink the way you move. Finds parking locations nearby, contains vehicle and finance details, dealer information and a host of useful guides.

Live Traffic access is free for the first 2 years following the purchase of a new Ford featuring SYNC 3 with navigation; thereafter there is an annual licence fee.

Illustrations, descriptions and specifications. This catalogue was correct at the time of going to print. However, Ford policy is one of continuous product development. The right is reserved to change specifications, colours and recommended prices of the models and items illustrated and described in this publication at any time. For the latest details always consult your Ford Dealer. **Optional equipment.** Throughout this publication, wherever a feature is described as being an 'Option' or 'Option Fitment/Pack' etc, you should assume that it will be at extra cost to the base vehicle, unless specifically stated to the contrary. All models and colour combinations are subject to availability. **Note.** Some images portrayed are of a pre-production model and/or are computer generated, therefore, the design/features on the final version of the vehicle may differ in various respects. In addition, some of the features shown on the vehicles may be optional. **Note.** This brochure contains both original Ford accessories as well as a range of products from our suppliers. Fitment of accessories may have an impact on your vehicle's fuel consumption. * The identified accessories are carefully selected third party supplier branded accessories which do not come with a Ford warranty but are covered by the third party supplier's own warranty, the details of which can be obtained from your Ford Dealer. **Note.** The Bluetooth® word mark and logos are owned by the Bluetooth SIG, Inc. and any use of such marks by Ford Motor Company is under licence. The iPod word mark and logos are the property of Apple Inc. Other trademarks and trade names are those of their respective owners. **Note.** Some driver assistance features and safety features described in this brochure are designed to function using sensors, whose performance may be affected under certain weather or environmental conditions.

The Government fuel figures do not express or imply any guarantee of the fuel consumption of any particular vehicle. The vehicles themselves have not been tested and there are inevitably differences between individual vehicles of the same model. In addition, a vehicle may incorporate particular modifications. Furthermore, the driver's style and road and traffic conditions, as well as the extent to which the vehicle has been driven and the standard of maintenance, will affect its fuel consumption. **Insurance groups** are only as recommended by the Association of British Insurers. You should always consult your insurance adviser for confirmation.

Ford One Call

In the unlikely event that your Ford Dealer can't help you or if you need to speak to us directly, call 0203 564 4444

Ford Rental – local service nationwide

Car and Van rental from our latest model range. Contact your local Ford Dealer for more information

Ford Motability

Call our Ford Motability team on 0345 6040019

Finance

Ford Credit Customer Services 0345 712 5490.
Ford Lease Customer Services 0344 600 1405
Calls to 0344 and 0345 numbers are charged at the same rate as a standard 01 or 02 geographic number, even when calling from a mobile.



Ford and BP – working together to reduce fuel consumption and emissions.

Published by Ford Motor Company Limited, Arterial Road, Laindon, Essex, England. Registered in England No. 235446.

FA 1597/6

BJN 207011. FoE H64E
PN 977504/1119/3m/GBR en
November 2019.

© Ford Motor Company Limited.

MY 2019.75 GBR en



Go Further