



Innovation
that excites

NISSAN GT-R



[Introduction](#) | [Exterior design](#) | [Performance](#) | [Interior design](#) | [Technology](#) | [Colours and Trims](#) | [GT-R Nismo](#) | [Technical Specifications GT-R](#) | [Technical Specifications GT-R Nismo](#) | [Price List](#)

[Print](#) | [Close](#)

[REQUEST A TEST DRIVE](#)



WHAT IF _

THE ONLY COMPETITION WAS YOURSELF?



[Introduction](#) | [Exterior design](#) | [Performance](#) | [Interior design](#) | [Technology](#) | [Colours and Trims](#) | [GT-R Nismo](#) | [Technical Specifications GT-R](#) | [Technical Specifications GT-R Nismo](#) | [Price List](#)

[Print](#) | [Close](#)

[REQUEST A TEST DRIVE](#)





CREATE YOUR OWN RULES.

The GT-R is built to be driven in real-world conditions, places other supercars wouldn't dare to tread. And now, that drive is even better, as GT-R adds a new level of sophistication and refinement with no compromise in performance. All this, and that "R" on the badge shines even brighter with the introduction of the GT-R Track Edition engineered by NISMO.

REQUEST A TEST DRIVE



TO LIVE WITHOUT LIMITATION.

Think how incredible it would be to drive a supercar as astonishing as the GT-R like it was any other car – in other words, anytime you wanted, for any and every reason, or just because it's yours. So drive it to the office or out to dinner. Take it on a trip over a long weekend. And of course, take it to the track. This is a GT-R after all.





**TAKUMI: ONE MAN,
ONE ENGINE.**

To see the pure passion, the true Japanese DNA of the GT-R, you only need to lift the bonnet. Only four master craftsmen in the world are allowed to hand-assemble the GT-R's engine. They are known as Takumi – a Japanese term used to describe a master craftsman who has perfected his skills over years of painstaking work and dedication. And with over 100 years of combined Takumi experience in building engines, the passion is very, very strong.

Each GT-R engine is assembled by a single Takumi – and proudly bears a plaque carrying their signature. Each Takumi inspects each piece for quality and to guarantee precision. But it's more than just exceptional skill that goes into the process that makes the GT-R so special. As one of the Takumi said, "we put our souls into each engine, hoping to deliver that excitement to customers".

1



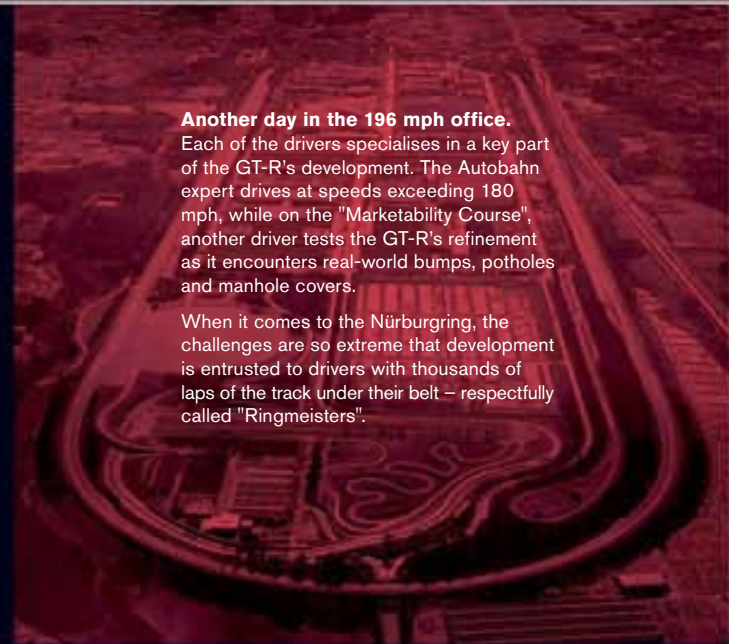

Another day in the 196 mph office.
 Each of the drivers specialises in a key part of the GT-R's development. The Autobahn expert drives at speeds exceeding 180 mph, while on the "Marketability Course", another driver tests the GT-R's refinement as it encounters real-world bumps, potholes and manhole covers.
 When it comes to the Nürburgring, the challenges are so extreme that development is entrusted to drivers with thousands of laps of the track under their belt – respectfully called "Ringmeisters".

**A TEAM OF EXPERT DRIVERS,
 ONE SINGULAR DRIVING EXPERIENCE.**

Master Craftsmanship is not only seen inside the clean-room conditions of the GT-R's engine-building facility – it is also found behind the wheel at the edge of the performance envelope.

Any one of the GT-R's development drivers alone would have made the Nissan GT-R an impressive vehicle. But from the beginning, we knew that the GT-R was going to redefine the breed in terms of performance, refinement and capabilities. So we brought together the top development drivers at Nissan to create a vehicle that would excel at any racetrack, in any weather, and be as rewarding to a novice enthusiast as it would be to a veteran racer.

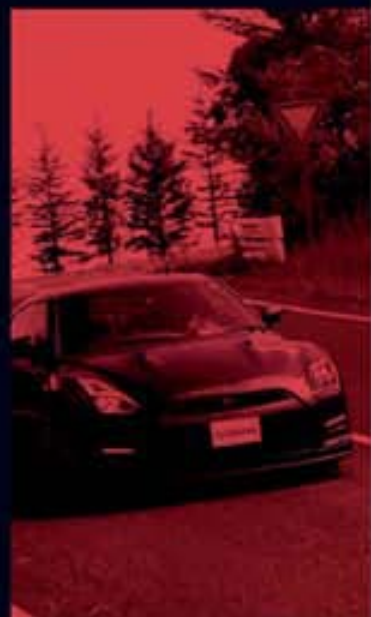

REQUEST A TEST DRIVE



0.26

THE ART OF AIRFLOW.

For supercars, managing airflow is a key challenge. Building on Nissan's extensive racing experience, the GT-R spent two years at the rolling-road wind tunnel at Group Lotus in Europe and 18 months in Yoshitaka Suzuka in Japan fine-tuning the secrets of bringing racecar aerodynamics to the street.

The results are an incredibly slippery 0.26 coefficient of drag, impressive levels of downforce, and superior air flow management and cooling of key components. Racing technology pays dividends you can enjoy on the street, giving the driver a feeling of superior stability, confidence and control.

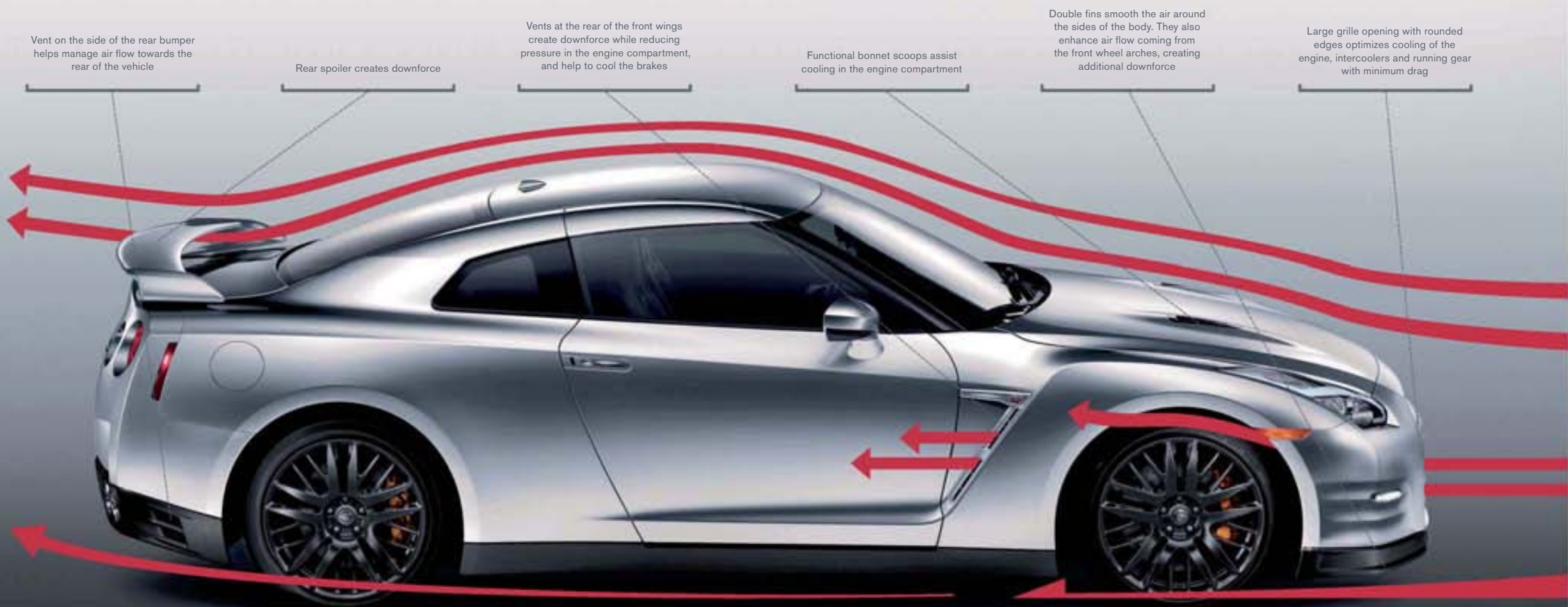

[REQUEST A TEST DRIVE](#)



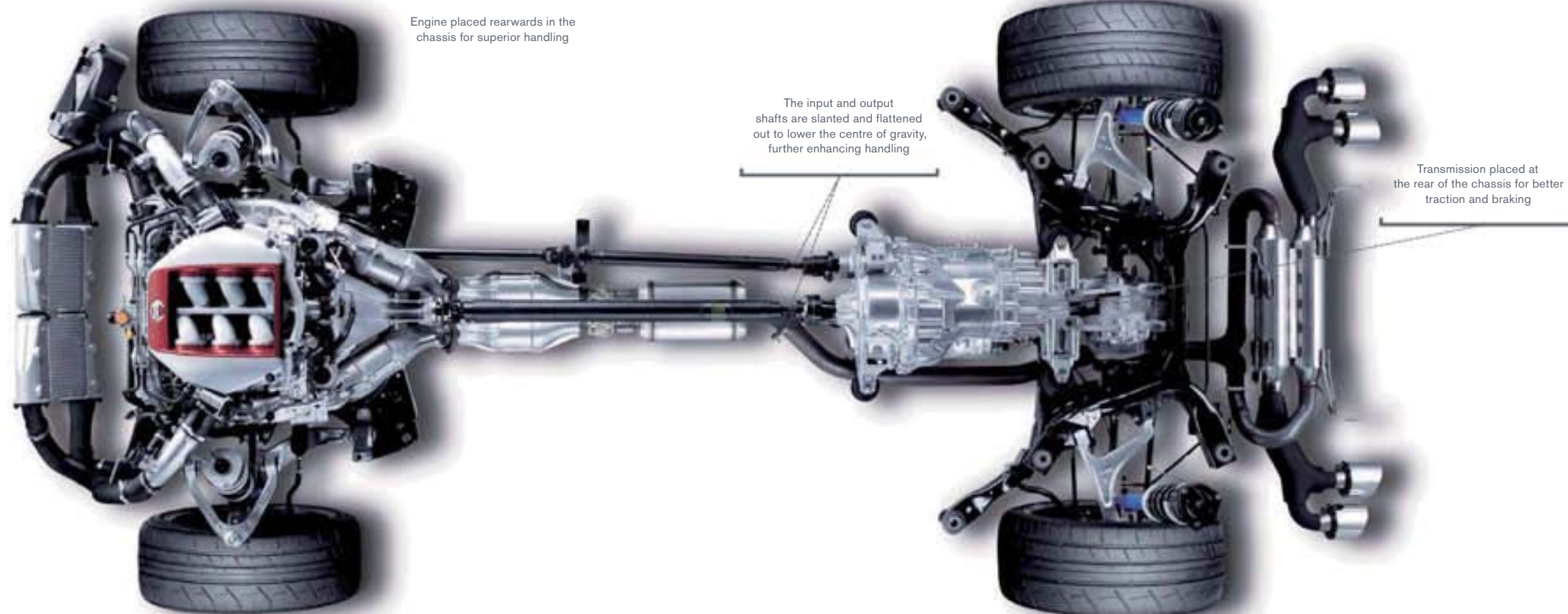

TO BREAK RECORDS, FIRST YOU BREAK THE RULES.

When designing and developing the GT-R, Nissan challenged tradition at every point. A perfect example: the GT-R's Premium Midship Platform. By moving the engine further back in the chassis, it reduces weight over the nose for better handling. In traditional layouts, this would place the transmission rearward, intruding into the passenger cabin.

The solution – separate the transmission from the engine, and mount it with the transfer case in the rear of the vehicle, creating the world's first independent rear transaxle for an All-Wheel Drive vehicle. By putting greater weight over the rear axle, traction and braking are improved. It even creates less heat between engine and transmission, allowing both to run cooler and more efficiently. A brilliant innovation in pursuit of handling perfection.

Two clutches. No clutch pedal. The Nissan GT-R's 6-speed dual-clutch transmission shifts incredibly quickly. How? Inside the transmission, there are separate clutches for the odd (1st, 3rd, 5th) and even (2nd, 4th, 6th) gears. When the car is in an odd-numbered gear, the adjacent even-numbered gear is "pre-selected" – ready to make the shift immediately. The transmission is so smart, it even "blips" the throttle on downshifts to match rpm.



Steering-column-mounted magnesium paddle shifters



Transmission settings: R-Mode, Normal and Save

CHANGE GEAR IN JUST 0.15 SECONDS.

The longer a gear change takes, the less time power is being put onto the road. So for maximum acceleration, the GT-R's paddle-shifted 6-speed sequential dual-clutch transmission can perform lightning-quick gear changes in just 0.15 seconds when in R-Mode – almost as fast as you can blink.

0.15

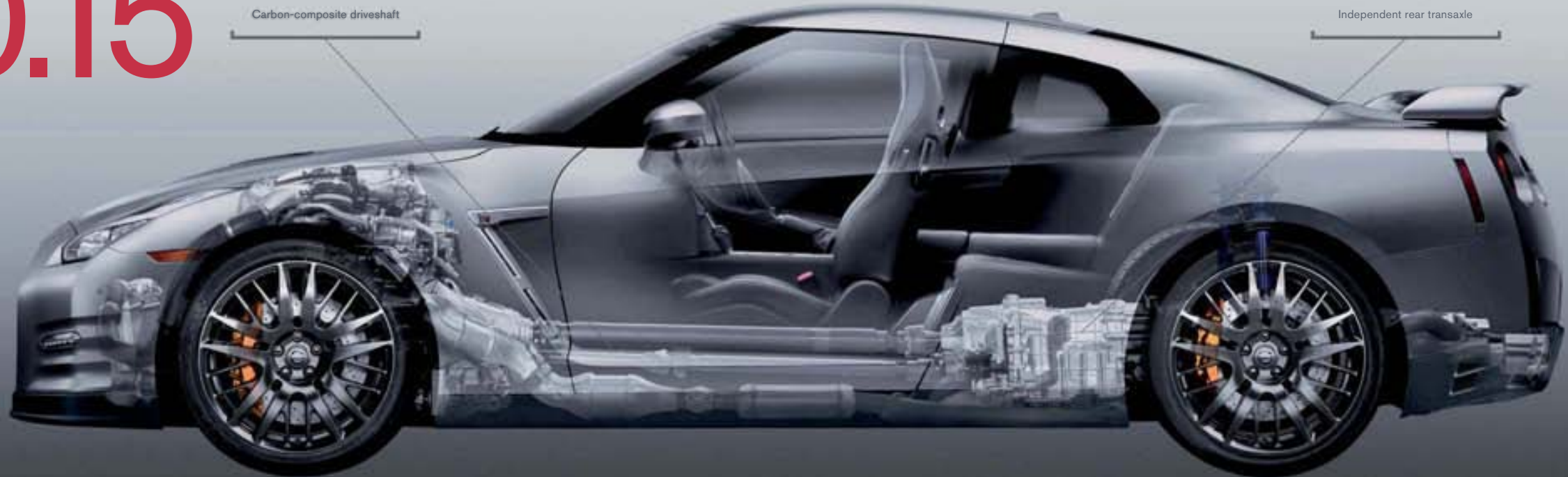



196 MPH

3.8L V6

The GT-R is powered by a twin-turbocharged 3.8L V6 that produces a staggering 550 PS and equally immense 632 Nm of torque. No detail was overlooked: rather than traditional cast-iron liners, each cylinder features a unique plasma coating sprayed onto the cylinder walls. This advanced process greatly reduces friction, allowing the engine to spin more freely, reducing wear for added durability, and improving cooling – a uniquely brilliant way to build an engine to perform under brutal conditions.

550 PS

The better an engine breathes, the better it works. For maximum performance, the Nissan GT-R features a fully independent intake system for each bank of cylinders. With a special secondary air system that helps heat the catalysts more quickly, the Nissan GT-R is not only powerful, it runs so clean that it's been certified as an Ultra Low Emissions Vehicle (ULEV).

632 NM OF TORQUE

AND BACK

6 PISTON CALIPERS

To complement its incredible horsepower and torque, the GT-R features awe-inspiring braking power. Look beyond the sheer size of the 390 mm front and 380 mm rear brake discs, and you'll see that Nissan has brought some of the biggest ideas in racing to this extraordinary road car. The brakes feature 6-piston front and 4-piston rear callipers for stronger, more even clamping power – something you'd expect to see on an all-out competition machine. In order to increase rigidity and reduce weight, the caliper is machined from a single piece of aluminum.

Dissipating braking heat is crucial. It's not uncommon to see the discs of racecars glowing bright red. Along with cross-drilled discs to help keep the Nissan GT-R's brakes cool, you'll find ingenious, diamond-shaped ventilation ribs to pull away heat. The GT-R also benefits from full-floating discs – a race-bred technology. By allowing the outer disc to expand away from the hub under extreme heat, it reduces the tendency of the disc to warp.





IT CORNERS LIKE IT IS READING YOUR MIND.

The GT-R boasts levels of refinement befitting a true Grand Touring machine. A retuned suspension better filters out the bumps and noise while still telling you everything you need to know. Steering effort is reduced at lower speeds for in-town manoeuvring while still delivering perfect precision. This all adds up to produce a balance that lets you feel fully confident to enjoy 550 PS and the adrenaline rush that arises from coming out of a corner with a brilliantly handling car at your fingertips.

The Nissan GT-R's ground-hugging aerodynamics and powerful brakes allow it to carry speed much later into the corner. But the real key to its speed is the All-Wheel Drive's ability to put the power down much sooner in a corner. Many powerful Rear-Wheel Drive cars require the driver to wait before applying power until the exit of the corner to avoid upsetting the handling of the car. In contrast, the GT-R powers out of the corner sooner and faster.

[REQUEST A TEST DRIVE](#)





MAKE ANY CONDITION "SUPERCAR WEATHER".

In tricky conditions when most supercars must stay in the garage or make a hasty retreat to warmer climates, the GT-R's advanced All-Wheel Drive gives you confidence. One of the most advanced All-Wheel Drive systems ever used in a road car, the system gives precise control of power to all four wheels. Combined with an equally advanced Vehicle Dynamic Control (VDC) system, you have superior security and stability. Anytime, anywhere.

Biased performance. Instead of the traditional 50/50 torque split between front and rear axles, the Nissan GT-R's electronically controlled All-Wheel Drive system is designed to provide up to 100% of available torque to the rear wheels, and can send up to 50% of torque to the front wheels as needed. This provides the steering feel and response of a Rear-Wheel Drive vehicle – the preferred choice of racers and enthusiasts – while still giving the added confidence and control that only an All-Wheel Drive vehicle can offer.



VDC that pulls for you. Most stability control systems cut engine power or apply the brakes when they sense a loss of control. Fine for the road, but slow going in competition conditions. When cornering with the GT-R's Vehicle Dynamic Control (VDC) system in R-Mode, it actually sends more power to the appropriate wheels when it senses oversteer or understeer, helping you drive with superior power and control.



THE DRIVE YOU DESIRE, JUST A FINGERTIP AWAY.

Whether you're out for a leisurely cruise, a time attack at your favorite track, or anywhere in between, the GT-R's easy-to-use 3-mode system is always ready. Three switches allow for adjustment of the transmission, suspension and VDC. The system has been fine-tuned to give a smooth and refined ride while enhancing roadholding and traction. This is performance with amazing flexibility, all at the flick of a switch.

| | R-MODE | NORMAL MODE | SPECIAL MODE |
|--------------|--|---|---|
| VDC | For ultimate performance. Adjusts front and rear wheel power distribution to enhance handling. | For daily driving. Controls brakes and engine output. | Off mode – Disengages the VDC system. |
| Suspension | For high-performance cornering. The damping force of the shock absorbers is set for maximum vehicle performance. | For automatic electronic control of damping. | Comfort mode – The damping force of the shock absorbers is variably adjusted for more comfort. |
| Transmission | For maximum performance with the quickest gear changes. | For maximum smoothness. | Save mode – For long-distance high-speed driving and gentler torque delivery for smooth driving on slippery surfaces. |



A PERSONAL INVITATION
TO UNFORGETTABLE
PERFORMANCE.

THE INTERFACE BETWEEN DRIVER AND GT-R. On all GT-R models as standard, the front driver and passenger seats are designed by legendary manufacturer Recaro®. Deep bolsters are designed to hold the driver and passenger in place, even during the most strenuous cornering. Superb support also makes the Recaro® seats excellent for grand touring. The seats are leather-appointed in a black and red contrasting colour scheme.



COMPLETELY CAPTIVATING.

Available in black, red or ivory, the optional leather seats and leather trim on the centre console, door panels and gear knob surround you in comfort and luxury.

[REQUEST A TEST DRIVE](#)





MAKING ALL THE RIGHT NOISES.

The Active Noise Cancellation (ANC) system uses a microphone in the ceiling to identify undesirable low-frequency engine sounds and neutralizes them with sound waves of the opposite phase. The result – a quieter driving experience which still preserves the enthralling sounds of the engine.

ARTFULLY STATE-OF-THE-ART.

The 11-speaker Bose® audio system was designed specifically for the GT-R. The die-cast aluminum structures in the doors and behind the rear seats not only make the car incredibly rigid, they're also an ideal way to mount speakers for optimum sound. Even the dual subwoofers between the rear seats were developed especially for the GT-R, and are mounted in a way to employ the boot as a giant amplifier, for incredibly deep, rich bass.

- USB port for iPod® connectivity
- AM/FM/CD audio system
- DVD video playback (when stationary)
- Bluetooth® audio streaming

A supercar shouldn't just be great on the open roads – it should also help you find them. With the GT-R's touch-screen navigation system with voice recognition and a high-resolution screen, the world is at your command. It features a hard drive-based system for quick response. And with DVD playback capability and a USB iPod® input, the entertainment will have no problem keeping pace. The system also includes a convenient rear colour reversing camera with a new function, offering 2 views - 130° view or a wide 180° view - so even parking is a quick and easy affair.

[REQUEST A TEST DRIVE](#)



SUPERCAR TECHNOLOGY AT YOUR FINGERTIPS.

Special attention to ergonomics means the Nissan GT-R feels familiar the moment you sit down – all gauges, including the multi-function display, are on the same plane, making for an easy scan, while instruments are large, clear and simple for maximum legibility.

Intuitive by design. Switchgear – from the door to the steering wheel mounted audio controls, climate control and the three setup switches – are at a similar height and are grouped by shape and function.

COMBINATION METRES.

The combination metres use meshing gears as a design cue. The tachometer is placed in the centre with a large gear change indicator on the upper right, supporting the driver with immediate readability when driving on the circuit.

INFORMATION AT THE SPEED OF LIGHT.

Like everything else in the GT-R, Nissan rethought the way the driver receives information. The high resolution 7" touch screen is an innovative way the driver can get immediate feedback on key performance parameters. The result is engaging and informative – providing quick readability combined with the flexibility of multiple customisable displays.

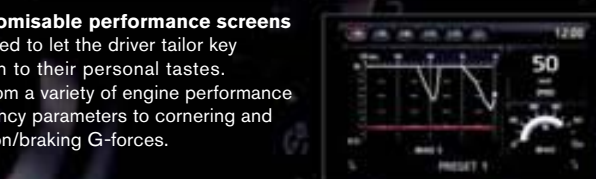

Five customisable performance screens are designed to let the driver tailor key information to their personal tastes. Choose from a variety of engine performance and efficiency parameters to cornering and acceleration/braking G-forces.

Factory preset screen. For proof of the GT-R's dedication to performance, look no further than the factory preset screen - a dedicated stopwatch activated from the steering wheel. You can even store your times using the USB port in the centre console.



LED: A REVOLUTION IN ILLUMINATION.

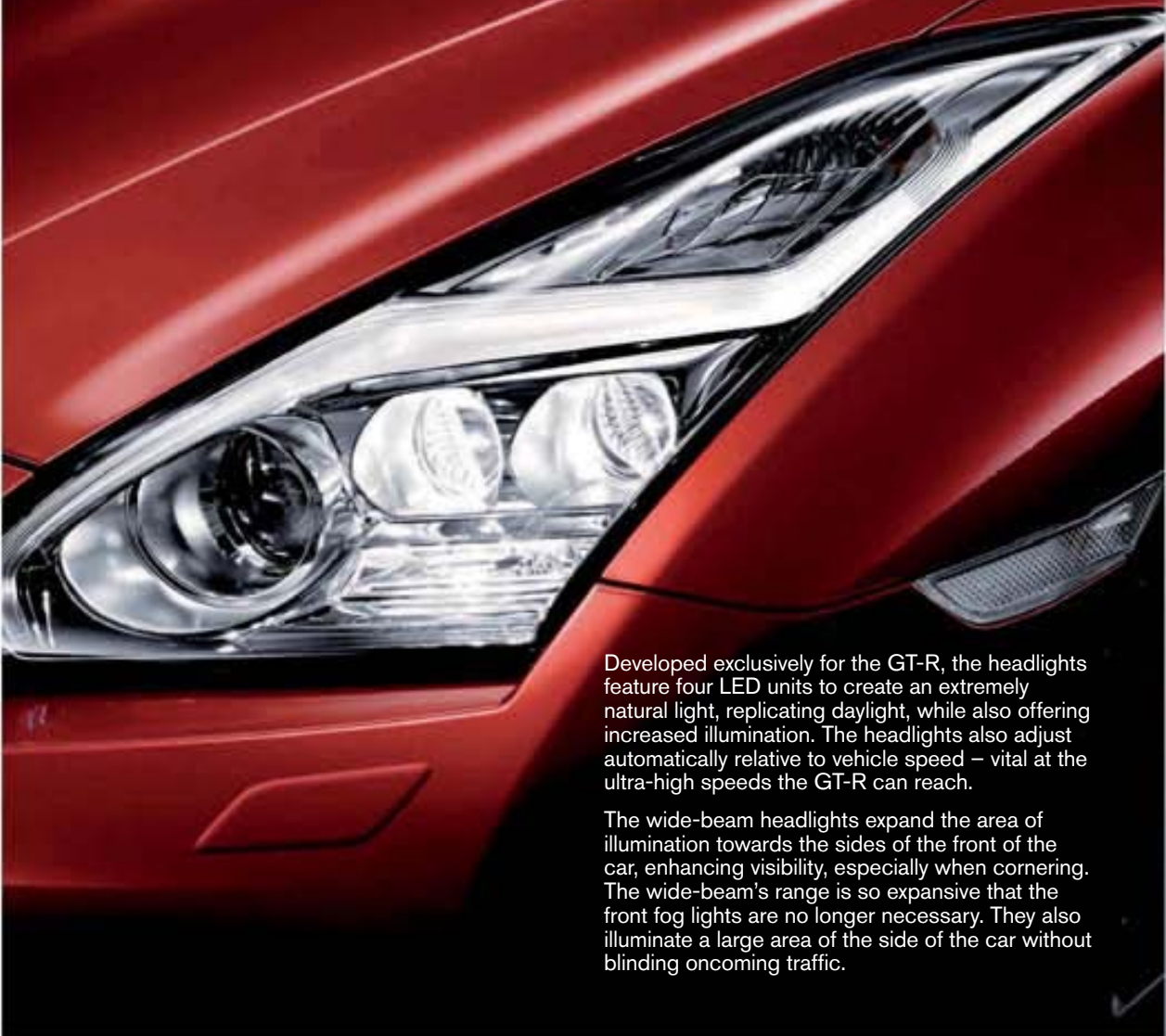

Developed exclusively for the GT-R, the headlights feature four LED units to create an extremely natural light, replicating daylight, while also offering increased illumination. The headlights also adjust automatically relative to vehicle speed – vital at the ultra-high speeds the GT-R can reach.

The wide-beam headlights expand the area of illumination towards the sides of the front of the car, enhancing visibility, especially when cornering. The wide-beam's range is so expansive that the front fog lights are no longer necessary. They also illuminate a large area of the side of the car without blinding oncoming traffic.

COLOURS AND TRIMS



Vibrant Red (S)*



Daytona Blue (M)*



Storm White (M)*



Gun Metallic (M)*



Pearl Black (M)*



Vermillion Red (SP)*



Ultimate Silver (SP)

*Anti scratch
M = METALLIC - S = SOLID - SP = SPECIAL PAINT



Premium Black leather interior.



Premium Red leather interior.



Premium Ivory leather interior.



Recaro® sports interior.

[REQUEST A TEST DRIVE](#)





A full 4-seater featuring the bespoke GT-R NISMO alloy wheels and tyres, suspension and unique body rigidity, the new Nissan GT-R Track Edition engineered by NISMO can tackle any turn.



NISSAN GT-R TRACK EDITION ENGINEERED BY NISMO CIRCUIT-TUNED, RACING TRIM

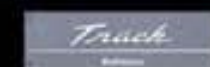

Legacy of Victory. The new Nissan GT-R Track Edition engineered by NISMO offers the ultimate supercar experience both on and off the circuit. Combining the dynamic handling of the GT-R NISMO with the style and comfort of the GT-R, it's the one you've been waiting for.





7:38.5
2007 // GT-R

7:18.6
2009 // GT-R

7:08.679
September 30, 2013
2013 // GT-R NISMO
(with the NISMO N Attack
Package)

EVOLUTION NEVER STOPS FOR THE NISSAN GT-R.

It has always been about passion. The Nürburgring is the great equaliser when it comes to supercar performance. Manufacturers from around the world come here to test and develop their ultimate performance machines. And for the very finest, there's always the challenge of setting record times.

During testing in 2007, the all-new GT-R created a sensation when it posted an official 7-minute, 38.5-second lap – the fastest lap ever for a production car. But for team GT-R, it was just the beginning. In 2009, the GT-R sent another shock wave through the performance world with an unofficial time of 7 minutes, 26.7 seconds. Why stop at just one lap? In May 2012, the GT-R returned to the Nürburgring to compete in a grueling 24-hour race. Against full-on race cars, the stock production GT-R took incredible punishment, and was able not only to finish – it was first in class.

Driven to constantly improve, on September 30, 2013, the all-new GT-R NISMO with the NISMO N Attack Package took to the Nürburgring, and ran an incredible 7:08.679, making it – once again – the fastest volume production car in the world. We cheered. We celebrated. And then we went back to work. Because where others see a finish line, we just see the start of the next lap.

The "Green Hell". Welcome to the Nürburgring, the world's most torturous track. 13 miles long, 73 bends in the picturesque Eifel mountains of Germany. The GT-R logged thousands of miles at the 'Ring, consistently recording lap times only matched by a few of the world's most capable – and most expensive – production cars.

[REQUEST A TEST DRIVE](#)



NISSAN GT-R NISMO

THE LEGEND OF GT-R. THE PASSION OF NISMO.

nismo

600_{PS}

A legacy of victory. Since 1984, NISMO has been the official in-house racing arm of Nissan. Started by a group of maverick Nissan engineers almost 30 years ago, NISMO is synonymous with passion, expertise, and the heights of Nissan performance – not to mention decades of racing dominance. The vehicles it creates have one goal in mind: that every time you see a NISMO badge, you'll know it's something extraordinary. The flagship of GT-R. The flagship of NISMO. Engineered with brilliance, designed with an undeniable edge, and most importantly, fueled by passion without a redline.



Strictly limited availability

[Introduction](#) | [Exterior design](#) | [Performance](#) | [Interior design](#) | [Technology](#) | [Colours and Trims](#) | [GT-R Nismo](#) | [Technical Specifications GT-R](#) | [Technical Specifications GT-R Nismo](#) | [Price List](#)

[Print](#) | [Close](#)

[Page 1](#) | [Page 2](#) | [Page 3](#)

REQUEST A TEST DRIVE





Innovation
that excites

NISSAN

MY15 GT-R



[Introduction](#) | [Exterior design](#) | [Performance](#) | [Interior design](#) | [Technology](#) | [Colours and Trims](#) | [GT-R Nismo](#) | [Technical Specifications GT-R](#) | [Technical Specifications GT-R Nismo](#) | [Price List](#)

[Print](#) | [Close](#)

[REQUEST A TEST DRIVE](#)



The MY15 GT-R continues the evolution of the Ultimate Everyday Supercar, combining usability with impressive refinement and heart-pounding excitement. You're always in control – with the transition from comfortable cruiser to maximum-attack 'R mode' just the flick of a switch away. With 550PS and 632Nm of torque, the MY15 GT-R is anything but the soft option.



MY15 GT-R

STANDARD FEATURES

ENGINE AND DRIVETRAIN

- 3.8-litre twin-turbocharged V6
- Electronic drive-by-wire throttle
- ATTESA ET-S Four-Wheel Drive (4WD) with patented independent rear-mounted transaxle

TRANSMISSION

- GR6 6-speed Dual Clutch Transmission with three driver-selectable modes
- Fully automatic shifting or sequential manual control via steering wheel-mounted paddle shifters
- Downshift Rev Matching (DRM)
- Predictive pre-shift control (in R-mode)
- R-START Mode - for optimum standing start performance

INTERIOR

- Recaro® seats and interior; optional premium black, red or ivory leather seats and interior
- Heated front seats
- 8-way power driver seat and 4-way passenger seat
- Dual individual rear seats
- Leather-wrapped steering wheel, handbrake and gear knob
- Carbon fibre trimmed centre console

BRAKES, SUSPENSION AND STEERING

- 4-wheel disc brakes - 390 mm front and 380 mm rear
- Asymmetrical suspension setup
- Front suspension - Double-wishbone with aluminium members
- Rear suspension - multi-link with aluminium members
- Bilstein® DampTronic system with three driver-selectable modes
- Electronically controlled rack-and-pinion steering with vehicle-speed-sensitive power assist

EXTERIOR

- RAYS® 10-spoke or optional 20-spoke lightweight 20" diameter forged aluminium wheels
- Dunlop SP SPORT MAXX 600® DSST CTT run-flat tyres - Nitrogen filled
- Body-colour rear spoiler with integrated high-mounted centre stop light
- Wide-beam automatic LED headlights
- LED Daytime Running Lights and LED rear lights
- Electric, heated and folding body coloured rear view door mirrors
- Flush-mounted aluminium door handles
- Quad exhaust exit pipes with chrome-tipped finishers
- UV-reducing solar glass

TECHNOLOGY

- NissanConnect Premium with:
 - High resolution 7" touch screen
 - Hard Disk Drive satellite navigation system
 - Rear colour reversing camera
 - 9.4GB Hard Disk Drive for music storage
 - Bluetooth® audio streaming and hands free phone system
 - USB port for Ipod® connectivity
 - AM/FM/CD audio system
 - DVD movie playback (when stationary)
 - Voice recognition
 - Multi-function meter which displays vehicle settings, vehicle information and performance telemetry
- Bose® audio system with 11 speakers
- Steering wheel mounted audio controls
- Active Noise Cancellation

COMFORT & CONVENIENCE

- Nissan Intelligent Key and push start button
- Dual-zone Automatic Climate Control
- Electric front windows
- Cruise control and speed limiter
- Rake and reach adjustable steering wheel
- Rain-sensing windscreen wipers
- Dual illuminated visor vanity mirrors
- 12V power sockets x2
- Front centre console with armrest, storage and dual cupholders
- Rear cupholder
- Map reading lamps
- Leather pull strap in boot lid

SAFETY

- Driver, passenger, side and curtain airbags
- Front seatbelts with pretensioners and load limiters
- Body construction including front and rear crumple zones and pedestrian safety pop-up bonnet
- ABS with EBD and Brake Assist
- Hood buckling creases, pipe-style steel side-door guard beams, and energy-absorbing steering column
- Electronic Traction Control
- Vehicle Dynamic Control (VDC)
- Tyre Pressure Monitoring System (TPMS)
- Nissan Anti Theft System Immobiliser
- Nissan approved alarm system
- Hill Start Assist - prevents rollback when starting on an incline
- Safety Kit (Warning Triangle, First Aid Kit and 2 High Visibility Jackets)



MY15 GT-R SPECIAL VERSION

TRACK EDITION ENGINEERED BY NISMO INCLUDING MY15 GT-R EQUIPMENT +

- NISMO exclusive GT500 6-spoke wheels
- Softer compound Dunlop® SP SPORT MAXX GT 600 DSST CTT Nitrogen filled run-flat tyres
- NISMO race tuned suspension
- NISMO body bonding for increased rigidity and improved on track performance
- Recaro® seats and interior
- Driver and passenger airbags

MY15 GT-R ACCESSORIES

- RAYS® 10-spoke lightweight 20" diameter forged aluminium wheels (x4) - Gun Metal
- RAYS® 10-spoke lightweight 20" diameter forged aluminium wheels (x4) - Light Silver
- Outdoor GT-R body cover - Grey
- Indoor GT-R body cover - Black
- Indoor GT-R body cover - Silver
- Nissan Tracking System Advanced
- Rear parking sensors
- Luxury mats
- Sport mats (with carbon heel pad)
- GT-R Jack and Jack Rod



Colours



Vibrant Red (A54)



Gun Metallic (KAD)



Daytona Blue (RAY)



Pearl Black (GAG)



Storm White (QAB)



Ultimate Silver (KAB)



Vermillion Red (NAS)

Trims



Recaro®



Premium Black Leather*



Premium Ivory Leather*



Premium Red Leather*

Alloy Wheels



GT-R Recaro Interior



GT-R Premium Interior



GT-R Track Edition
engineered by NISMO

*Some parts of leather trim may contain artificial leather

| MODEL | | |
|-------------------------------------|-------------------|---|
| Grade | | GT-R GT-R Track Edition engineered by NISMO |
| Seating capacity | persons | 4 |
| ENGINE | | |
| Engine code | | VR38DETT |
| No. of cylinders, configuration | | V6 Twin Turbo |
| Valves per cylinder | | 4 |
| Cam design | | DOHC continuously variable valve timing |
| Engine capacity | cm ³ | 3799 |
| Bore x stroke | mm | 95.5 x 88.4 |
| Max. engine power 1) | kW(PS)/min-1 | 404 (550PS) @ 6400rpm |
| Max. torque 1) | Nm/min-1 | 632 @ 3200 to 5800 rpm |
| Fuel type | | Unleaded Petrol RON 100 |
| Ignition system | | Nissan Direct Ignition System |
| Fuel supply | | Multi Point Injection |
| Emissions Certification Level | | Euro 5b+ |
| Emission control system | | 3-way catalyst and secondary air injection system |
| DRIVE TRAIN | | |
| Drive configuration | | Independent transaxle 4WD |
| Transmission | | GR6 dual clutch transmission |
| Gear ratio | 1st | 4.0565 |
| | 2nd | 2.0316 |
| | 3rd | 1.5950 |
| | 4th | 1.2486 |
| | 5th | 1.0012 |
| | 6th | 0.7964 |
| | Reverse | 3.3830 |
| | Final drive ratio | Front 2.9375 / Rear 3.7000 |
| Limited slip differential | | 1.5 Way Mechanical LSD |
| CHASSIS | | |
| Suspension front | | Double wishbone with aluminium (forged) upper links and lower arms |
| Suspension rear | | Multi-link with aluminium (forged) upper links |
| Shock absorbers front | | Bilstein adaptive DampTronic |
| Shock absorbers rear | | Bilstein adaptive DampTronic |
| Steering | | Electronically controlled rack & pinion with vehicle-speed-sensitive power assist |
| Steering turns - lock to lock | | 2.4 |
| Brakes | | Ventilated discs with opposed and cast aluminium caliper (6 pistons for front and 4 pistons for rear) |
| Front brakes diameter and thickness | | 390 x 32.6 |
| Rear brakes diameter and thickness | | 380 x 30 |
| Wheel and tyre size | | 255/40 ZRF 20 (front), 285/35 ZRF 20 (rear) / 20"x9.5" (front), 20"x10.5" (rear) |

| MODEL | | |
|-----------------------------------|---------|---|
| Grade | | GT-R GT-R Track Edition engineered by NISMO |
| WEIGHTS & DIMENSIONS | | |
| Kerb weight min 2) | kg | 1740 |
| Weight distribution (front/rear) | % | 53-54/47-46 |
| Gross Vehicle Weight | kg | 2200 |
| Max. axle weight front | kg | 1080 |
| Max. axle weight rear | kg | 1165 |
| Overall length | mm | 4670 |
| Overall width | mm | 1895 |
| Overall height | mm | 1370 |
| Wheelbase | mm | 2780 |
| Track width (front) | mm | 1590 |
| Track width (rear) | mm | 1600 |
| Turning circle (wall to wall) | mm | 12103 |
| Coefficient of drag (cd) | | 0.26 |
| Minimum ground clearance | mm | 105 |
| Approach angle | degrees | 9.8 |
| Departure angle | degrees | 16.5 |
| Luggage space - min. length/max. | mm | 695/840 |
| - min. width/max. | mm | 795/1470 |
| - min. height/max. | mm | 430/520 |
| Luggage capacity | l | 315 |
| Fuel tank capacity | l | 74 |
| PERFORMANCE | | |
| Fuel consumption 3) - Urban cycle | mpg | 16.6 |
| - Extra-urban | mpg | 32.1 |
| - Combined | mpg | 23.9 |
| CO ₂ mass emission | g/km | 275 |
| Max. speed | mph | 196 |

1) In accordance with 1999/99/EC.

2) Figures in accordance with EC directive. Kerb weight condition is without driver and including coolant, oils, fuel, spare wheel and tools. Pay load will be reduced depending on the options and/or accessories installed.

3) In accordance with 1999/100/EC. (Optional equipment, maintenance, driving technique, road and weather conditions may affect the official results)



OUR PROMISE. YOUR EXPERIENCE.



There's no time limit on how long you will benefit from our promises. If you are a Nissan Customer, we will look after you. **That is our Promise.**



FREE COURTESY CAR

YOU want to stay on the road when your Nissan is in for a service or repair.

NISSAN PROMISE to keep you mobile free of charge whether you need a courtesy car, or just a lift.



FREE VIDEO HEALTH CHECK

YOU want to understand what is going on with your car's service.

NISSAN PROMISE a free vehicle health check and we can even show you any work that might need doing with your own vehicle assessment video.



SERVICE PRICE MATCH

YOU want the best value for money when it comes to service and repair.

NISSAN PROMISE simple Fixed Price Servicing, and will price match like-for-like competitor written quotes within 10 miles of your local dealer.



CONTINUOUS ROADSIDE ASSISTANCE

YOU want the peace of mind you get from our quality service to go even further.

NISSAN PROMISE to provide you with Roadside Assistance for free every time you service your car with us.



HERE FOR YOU

YOU want your problems resolved quickly.

NISSAN PROMISE to propose a resolution to any problem within two working days.



TEST DRIVE YOUR CHOICE

YOU want to test drive the latest Nissan model, engine and gearbox you're interested in buying.

NISSAN PROMISE that's what you'll get when you pre-book your test drive either online or through our customer service centre.

Just call 0330 123 1231.

Please visit nissan.co.uk/promise. Terms and conditions apply.





Innovation
that excites

NISSAN GT-R NISMO



[Introduction](#) | [Exterior design](#) | [Performance](#) | [Interior design](#) | [Technology](#) | [Colours and Trims](#) | [GT-R Nismo](#) | [Technical Specifications GT-R](#) | [Technical Specifications GT-R Nismo](#) | [Price List](#)

[Print](#) | [Close](#)

[REQUEST A TEST DRIVE](#)



With DNA from the legendary NISMO racing team, the ultimate GT-R is a race-oriented model delivering factory tuned supercar performance with revolutionary aerodynamics and ultra-precise handling. The GT-R is already established as one of the best performing supercars, and now Nissan has drawn on decades of racing experience, to develop the ultimate Nissan GT-R.



GT-R NISMO STANDARD FEATURES

ENGINE

- 3.8-litre twin-turbocharged V6
- Dual overhead camshafts with variable intake-valve timing
- Die-Cast aluminium cylinder block with super-low-friction high-endurance/low-friction plasma-sprayed bores
- Aluminium pistons
- Nissan Direct Ignition system with iridium-tipped spark plugs
- Electronic drive-by-wire throttle
- Pressurised lubrication system with thermostatically controlled cooling and magnesium oil sump pan
- Fully symmetrical dual intake and low-backpressure stainless steel exhaust systems
- Secondary air intake system to rapidly heat catalysts to peak cleaning efficiency
- Aluminium plate engraved with the Takumi name
- NISMO red exclusive engine

DRIVETRAIN

- ATTESA E-TS Four-Wheel Drive (4WD) with patented independent rear-mounted transaxle integrating transmission, differential and 4WD transfer case
- Rigid, lightweight carbon-composite propeller shaft between engine and transaxle
- Electronic Traction Control
- High-performance 1.5-way mechanically locking rear differential
- Advanced Electronic Stability Program (ESP) with three driver-selectable settings
- Differential Oil R35 COMPETITION type 2189E

TRANSMISSION

- GR6 6-speed dual clutch transmission with three driver-selectable modes
- Fully automatic shifting or sequential manual control via steering wheel-mounted paddle shifters
- Downshift Rev Matching (DRM)
- Predictive pre-shift control (in R-mode) preselects the next gear change based on throttle position, vehicle speed, braking input and other information

BRAKES

- 4-wheel disc brakes – 390 mm front and 380 mm rear
- Two-piece floating front and rear discs with diamond-pattern internal ventilation
- Super-rigid 6-piston front/4-piston rear monoblock calipers with 3-point mounting front / 2 point mounting rear
- Nissan Brake Assist
- Brake cooling system with carbon brake air duct

BODY CONSTRUCTION

- Premium Midship platform with hybrid unibody
- Real carbon boot lid
- Die-cast aluminium front suspension turrets and door structures
- Die-cast aluminium rear seat back support
- Integrated X pattern roof inner
- Multiple-strike, coining process body panel for exceptional rigidity and precision
- Carbon-composite front crossmember/radiator support
- Carbon with aluminium honeycomb strut support bar
- Advanced 6-stage paint process with full double clearcoat or chip-resistant paint

WHEELS AND TYRES

- RAYS 20" forged-aluminium wheels, 6-spoke, 10.0" wide front, Exclusive racing NISMO black colour coat
- DUNLOP SP SPORT MAXX GT 600 DSST CTT run-flat summer tyres - Nitrogen filled
- Tyre Pressure Monitoring System (TPMS)

SUSPENSION AND STEERING

- Front suspension – double-wishbone with aluminium (forged) upper links and lower arms
- Rear suspension – Multi-link with aluminium (forged) upper arms
- Front RH/LH asymmetry suspension setting
- Bilstein® DampTronic system with three driver-selectable modes
- Exclusive Bilstein DampTronic Shock Absorber (electronically-controlled, exclusive color)
- Rigid front and rear suspension subframes, assembled in high-precision jigs, with 6 point mounting to body
- Hollow front and solid rear anti-roll bars with tubular torsion-free design, to help maintain maximum tyre contact at all four wheels during extreme cornering
- Electronically controlled rack-and-pinion steering with vehicle-speed-sensitive power assist
- 2.4 steering wheel turns lock-to-lock

AERODYNAMICS

- Full underbody covering
- NISMO exclusive carbon side sill spoiler
- Carbon front under cover with cooling duct
- Carbon racing rear wing spoiler - centre mounted
- Racing car shaped carbon front and rear bumper with NISMO design red line
- Rear bumper side air duct

STYLING AND FUNCTIONALITY

- Automatic headlights
- Super wide-beam LED headlights with Active Front Lighting System (AFS)
- LED daytime running lights
- LED rear lights, brake lights, rear foglight
- Electric, heated and folding rear view exterior mirrors
- Dual exhaust exit pipes with chrome-tip finishers

SAFETY

- Nissan advanced airbag technology with dual-stage front driver and passenger airbags
- Front seat belts with pre-tensioners and load limiters
- 3-point ELR seat belt system
- Nissan Zone Body Construction with front and rear crumple zones
- Bonnet buckling creases, pipe-style steel side-door guard beams, and energy-absorbing steering column
- Nissan Vehicle Immobilizer System
- Thatcham Approved anti-theft system
- Rear seat ISO-FIX
- Safety Kit (Warning Triangle, First Aid Kit and 2 High Visibility Jackets)

AUDIO, NAVIGATION AND PERFORMANCE MONITOR

- Radio, CD, HDD Music Box system, including 30-GB hard drive with 9.3 GB for audio storage.
- Digital Bose® audio system with AM/FM/CD, Radio Data System (RDS), MP3/WMA/AAC CD playback and MP4/DivX DVD playback
- USB Port for iPod® connectivity, MP4 playback and image viewer via memory stick
- Exclusive NissanConnect NISMO
- Bluetooth® audio streaming capability
- Steering wheel-mounted audio controls
- HDD-based GPS Nissan Navigation System with Voice Recognition
- Monitor provides display and interface for audio and navigation systems, as well as for programmable vehicle settings and vehicle information

CONVENIENCE

- Set-up switches: Transmission: R mode, Normal mode, SAVE mode; Shock absorber: R mode, Normal mode, Comfort mode; VDC-R: R mode, Normal mode & OFF mode button
- Push Engine Start
- Rear View Camera, with super wide mode
- Dual automatic climate control air conditioning with microfilter
- Electronic analogue instrument cluster with multi-function trip computer and digital gear indicator.
- Bluetooth® hands-free phone system
- Intelligent Key System
- Cruise control with steering wheel-mounted controls
- Tilt and telescoping steering column
- Rain-sensing flat-blade windscreen wipers
- Dual illuminated visor vanity mirrors
- 12V Power socket
- Map reading lights

SEATING AND TRIM

- Exclusive Alcantara® black and red powered carbon bucket Recaro® seats with NISMO emblem and red stitching
- NISMO Exclusive badge
- Slide Manual and reclining electric seats
- Dual individual rear seats
- NISMO exclusive dark grey Alcantara® steering wheel with leather red centre marker
- Black roof trim & sunvisor
- Carbon fibre trimmed instrument cluster
- Aluminium mood door grip finisher, air conditioning grill, cluster finisher, center console finisher

| 2 door Coupe | | |
|-------------------------------------|---|----------------------------|
| MODEL | | |
| Available grades | GT-R NISMO | |
| Seating capacity | persons | 4 |
| ENGINE | | |
| Engine code | VR38DETT | |
| No. of cylinders, configuration | V6 Twin Turbo | |
| Valves per cylinder | 4 | |
| Cam design | DOHC continuously variable valve timing | |
| Engine capacity | cm ³ | 3799 |
| Bore x stroke | mm | 95.5 x 88.4 |
| Max. engine power 1) | kW(PS)/min-1 | 441 (600PS) @ 6800rpm |
| Max. torque 1) | Nm/min-1 | 652 @ TBC rpm |
| Fuel type | Unleaded Petrol RON 100 | |
| Ignition system | Nissan Direct Ignition System | |
| Fuel supply | Multi Point Injection | |
| Emissions Certification Level | Euro 5b+ | |
| Emission control system | 3-way catalyst and secondary air injection system | |
| DRIVE TRAIN | | |
| Drive configuration | Independent transaxle 4WD | |
| Transmission | GR6 dual clutch transmission | |
| Gear ratio | 1st | 4.0565 |
| | 2nd | 2.0316 |
| | 3rd | 1.5950 |
| | 4th | 1.2486 |
| | 5th | 1.0012 |
| | 6th | 0.7964 |
| | Reverse | 3.3830 |
| | Final drive ratio | Front 2.9375 / Rear 3.7000 |
| Limited slip differential | 1.5 Way Mechanical LSD | |
| CHASSIS | | |
| Suspension front | Double wishbone with aluminium (forged) upper links and lower arms | |
| Suspension rear | Multi-link with aluminium (forged) upper links | |
| Shock absorbers front | Bilstein adaptive DampTronic | |
| Shock absorbers rear | Bilstein adaptive DampTronic | |
| Steering | Electronically controlled rack & pinion with vehicle-speed-sensitive power assist | |
| Steering turns - lock to lock | 2.4 | |
| Brakes | Ventilated discs with opposed and cast aluminium caliper (6 pistons for front and 4 pistons for rear) | |
| Front brakes diameter and thickness | 390 x 32.6 | |
| Rear brakes diameter and thickness | 380 x 30 | |
| Wheel and tyre size | 255/40 ZRF 20 (front), 285/35 ZRF 20 (rear) / 20"x10" (front), 20"x10.5" (rear) | |

| 2 door Coupe | | |
|-----------------------------------|---------|-------------|
| WEIGHTS & DIMENSIONS | | |
| Kerb weight min 2) | kg | 1720 |
| Weight distribution (front/rear) | % | 52-56/48-44 |
| Gross Vehicle Weight | kg | 2200 |
| Max. axle weight front | kg | 1080 |
| Max. axle weight rear | kg | 1165 |
| Overall length | mm | 4680 |
| Overall width | mm | 1895 |
| Overall height | mm | 1370 |
| Wheelbase | mm | 2780 |
| Track width (front) | mm | 1600 |
| Track width (rear) | mm | 1600 |
| Turning circle (wall to wall) | m | 12.3 |
| Coefficient of drag (cd) | | 0.26 |
| Minimum ground clearance | mm | 105 |
| Approach angle | degrees | 9.2 |
| Departure angle | degrees | 16.0 |
| Luggage space - min. length/max. | mm | 695/840 |
| - min. width/max. | mm | 795/1470 |
| - min. height/max. | mm | 430/520 |
| Luggage capacity | l | 315 |
| Fuel tank capacity | l | 74 |
| PERFORMANCE | | |
| Fuel consumption 3) - Urban cycle | mpg | 16.6 |
| - Extra-urban | mpg | 32.1 |
| - Combined | mpg | 23.9 |
| CO ₂ mass emission | g/km | 275 |
| Max. speed | mph | 196 |

*All specifications throughout this brochure are subject to final homologation.

1) In accordance with 1999/99/EC.

2) Figures in accordance with EC directive. Kerb weight condition is without driver and including coolant, oils, fuel, spare wheel and tools. Payload will be reduced depending on the options and/or accessories installed.

3) In accordance with 1999/100/EC. (Optional equipment, maintenance, driving technique, road and weather conditions may affect the official results)

Colours & Trims

COMMITMENTS

YOU + NISSAN



Storm White (QAB)



Pearl Black (GAG)



Ultimate Silver (KAB)



Stealth Grey (KBL)



NISMO Carbon Fibre Recaro® Seats*



Seat Back

YOU CARE ABOUT YOUR NISSAN SO NISSAN WILL CARE FOR YOU.
THAT'S WHY WE'LL MAKE THE FOLLOWING COMMITMENTS:

YOU care about staying on the road when your Nissan is in for service or repair.

YOU care about quality enough to have your Nissan serviced at a Nissan dealership.

YOU care about getting the best value for money when it comes to service and repair.

YOU care about having your problems resolved quickly.

YOU care about getting the right Nissan model, engine & gear box to test drive.

NISSAN will keep you mobile free of charge.

NISSAN says thanks by giving you continuous Nissan roadside assistance for free.

NISSAN will price match like for like competitor written quotes within 10 miles of your local dealer.

NISSAN will propose how to resolve any problem within 2 working days.

NISSAN will guarantee that's what you'll get when you pre-book your test drive either online or through our customer service centre.

YOU + NISSAN
CARE

ALL ABOUT NISSAN

*Some parts of leather trim may contain artificial leather



[REQUEST A TEST DRIVE](#)





GT-R

| Body | Version | Engine | Transmission | Basic Price | VAT | Total Retail | On The Road Price |
|-----------------------------------|-----------------|-------------------------|-----------------------------------|-------------|-----------|--------------|-------------------|
| Coupé | Recaro | 3.8 V6 Twin Turbo 550PS | GR6 - paddle shift with auto mode | 64,062.50 | 12,812.50 | 76,875 | 78,030 |
| | Premium (Black) | | | 66,762.50 | 13,352.50 | 80,115 | 81,270 |
| | Premium (Red) | | | | | | |
| | Premium (Ivory) | | | | | | |
| Track Edition Engineered by NISMO | 72,837.50 | 14,567.50 | 87,405 | 88,560 | | | |

GT-R available from NISMO Centres only. Basic and Total Retail includes delivery to the Dealership and number plates. On the Road Price includes 12 months Government Vehicle Excise Duty (determined by CO₂ emissions figure and fuel type- see back page for details) and £55 Government First Registration Fee.



[REQUEST A TEST DRIVE](#)



GT-R OPTIONS

| | GT-R | Basic | VAT | Total |
|---|----------------------------------|----------|--------|-------|
| Paint: Vermillion Red or Ultimate Silver | <input type="radio"/> | 1,458.33 | 291.67 | 1,750 |
| Paint: Pearl Black, Storm White, Daytona Blue or Gun Metallic | <input type="radio"/> | 708.33 | 141.67 | 850 |
| Paint: Vibrant Red | <input checked="" type="radio"/> | - | - | - |
| Nissan Tracking System Advanced ^{#^} | <input type="checkbox"/> | 762.27 | 151.73 | 914 |
| Nissan High Performance Coatings (Paint, Glass, Alloy wheels & Fabric)** | <input type="checkbox"/> | 415.83 | 83.17 | 499 |
| Protection Pack (luxury floor mats, GT-R body cover, Nissan Tracking System Advanced) | <input type="checkbox"/> | 1,000.00 | 200.00 | 1,200 |
| Rear park sensors | <input type="checkbox"/> | 308.78 | 61.22 | 370 |
| GT-R body cover in black or silver (for indoor use only)* | <input type="checkbox"/> | 255.00 | 51.00 | 306 |
| GT-R body cover, Weathershield Grey (suitable for outdoor use) | <input type="checkbox"/> | 275.00 | 55.00 | 330 |
| Luxury floor mats | <input type="checkbox"/> | 90.78 | 17.22 | 108 |
| Premium sports mats with carbon heel pad | <input type="checkbox"/> | 785.14 | 156.86 | 942 |

Standard - ● Optional - ○ Optional Dealer Fit - □

* Cover comes in a holdall featuring the GT-R logo.

** Products supplied by Tribos. Professionally applied. Contact your NISMO Centre for details.

Price includes one years free subscription.

Dealer fit option prices include fitting but are only a guide. Please check with your local NISMO Centre for exact prices.

^ Additional subkit required

CO2 MASS EMISSIONS AND VEHICLE EXCISE DUTY

| Vehicle | Engine | Transmission | Body Style | Emission Level | CO ₂ Mass Emissions g/km | | 12 months VED* | |
|---------|-------------------------|---|------------|----------------|-------------------------------------|-------------|----------------|-------------|
| | | | | | ≤17" Alloys | ≥18" Alloys | ≤17" Alloys | ≥18" Alloys |
| GT-R | 3.8 V6 Twin Turbo 550PS | GR6 - twin clutch paddle shift with auto mode | Coupé | EURO6 | 275 | | £1,100 | |

* Determined by CO₂ emissions figure and fuel type - see "Further information". NB. Navara VED is fixed at £225 as it is considered a commercial vehicle.

NISSAN CARE WARRANTY

- Provides protection for up to 3 additional years **on top of the New Vehicle Warranty.**
- Available for vehicles under 3 years old/60,000 miles from point of purchase.

| Model | Retail exc. VAT | Retail inc. VAT |
|---------------------------|-----------------|-----------------|
| NEW MICRA | £190.30 | £229 |
| NOTE | £194.46 | £239 |
| NEW PULSAR | £315.00 | £378 |
| JUKE | £214.02 | £259 |
| QASHQAI / JUKE NISMO | £232.13 | £279 |
| X-TRAIL / ALL NEW X-TRAIL | £506.67 | £608 |
| GT-R | £3,356.67 | £4,028 |

Prices above are for an additional 1 Year Nissan Care Warranty on top of the standard new car warranty. The warranty expires either 4 years or 60,000 miles from the date of vehicle registration, whichever comes first. Further age/mileage options are available.

| Duration | Navara | | NV200 Combi | |
|---|-----------------|-----------------|-----------------|-----------------|
| | Retail exc. VAT | Retail inc. VAT | Retail exc. VAT | Retail inc. VAT |
| 5 Years up to 125,000 Miles (+25,000 miles) | £670.83 | £805 | £562.50 | £675 |
| 5 Years up to 150,000 Miles (+50,000 miles) | £875.00 | £1,050 | £733.33 | £880 |
| 6 Years up to 125,000 Miles (+1 Year / 25,000 miles) | £1,400.00 | £1,680 | £1,175.00 | £1,410 |
| 6 Years up to 150,000 Miles (+ 1 Year / 50,000 miles) | £1,837.50 | £2,205 | £1,537.50 | £1,845 |

- Provides protection on top of the New Vehicle Warranty (5yr/100k mile) for the following models. Prices effective from 1st September 2015..

NISSAN INSURANCE

Nissan Insurance has been designed to help Nissan drivers get the most from their cover, boasting the following benefits:

- Use of Nissan Approved Repairers and franchised trained technicians
- Use of only Nissan genuine parts for repairs
- Guaranteed repair for 3 years
- New car replacement, if your vehicle is written off when under 12 months old
- Cover provided for driving in the EU, subject to a maximum 30 days per year
- Personal accident benefit up to £5,000
- Up to £100 personal belongings cover
- £300 towards replacement locks if your keys are lost or stolen

Call Nissan Insurance today on **0344 335 3780**

Calls charged at the same rate as local 01 and 02 numbers and will be included in inclusive call packages from mobiles. Lines are open Monday to Friday 9am-7pm and Saturday 9am-5pm.

Terms and Conditions

Quotations are subject to underwriting terms and acceptance criteria.

Nissan Insurance is arranged by Europa Group Ltd trading as Nissan Insurance Services on behalf of Maiden Global Holdings Ltd (registered in England with company number 07324422) Registered office: Albion House, Valley Business Centre, Gordon Road, High Wycombe, HP13 6EQ. Authorised and regulated by the Financial Conduct Authority. Financial Services Register number 555397.

Europa Group Limited is authorised and regulated by the Financial Conduct Authority. Financial Services Register No. 309794. Registered as a limited company in England and Wales No. 3279177. Registered office: Europa House, Midland Way, Thornbury, Bristol BS35 2JX.

FURTHER INFORMATION

On The Road Prices. On The Road Price includes 12 months Government Vehicle Excise Duty (VED) determined by CO₂ emissions figure and fuel type, £55 Government First Registration Fee, number plates and delivery to the Nissan Dealership.

VED rates are determined by the vehicles CO₂ emissions figures and by the type of fuel used. The following table applies to all new car registrations:

| VED Band | A | B | C | D | E | F | G | H | I | J | K | L | M |
|--|------------|----------|----------|----------|----------|----------|----------|----------|----------|----------|----------|----------|-----------|
| CO ₂ Emissions Figure (g/km)* | up to 100g | 101-110g | 111-120g | 121-130g | 131-140g | 141-150g | 151-165g | 166-175g | 176-185g | 186-200g | 201-225g | 226-255g | over 255g |
| Petrol Car | £0 | £0 | £0 | £0 | £130 | £145 | £180 | £295 | £350 | £490 | £640 | £870 | £1,100 |
| Diesel Car | £0 | £0 | £0 | £0 | £130 | £145 | £180 | £295 | £350 | £490 | £640 | £870 | £1,100 |
| Alternative Fuel Car | £0 | £0 | £0 | £0 | £115 | £130 | £165 | £275 | £325 | £465 | £610 | £830 | £1,055 |

* g/km = grammes of CO₂ per kilometre travelled.

All Light Commercial Vehicles will have a standard VED rate of £225 per annum.

VAT and VED

VAT application is based on current HMRC guidelines, please check with HMRC for specific guidance for the vehicle you are purchasing.

VED is determined by the DVLA, please check with the DVLA for specific guidance for the vehicle you are purchasing.

Optional equipment. This price list features a selection from the full range of optional equipment, be they standard, dealer fit or factory options.

For further information and details of the full range, please contact your local Authorised Nissan Dealer.

Nissan's commitment to you includes all of the following benefits – some of which may be the reasons why you chose your new Nissan in the first place:

Manufacturer's warranty – Nissan's comprehensive warranty provides cover for your new Nissan from defects in materials or workmanship. Your vehicle is covered in all European Countries where Authorised Nissan Dealers are located. If your vehicle becomes inoperative due to a warrantable defect a towing service, when necessary, to the Authorised Nissan Dealer is covered. If a warrantable defect abroad takes more than six hours to repair, the Touring Assistance Programme will pay for a hotel room or rental car up to a certain maximum. The paint warranty covers painted body parts (excluding the underbody) for three years regardless of mileage driven. For further details please contact your local Authorised Nissan Dealer. Petrol and diesel engine cars - Three-year/60,000 miles. Petrol and diesel engine LCVs and Navara - Five-year/100,000 miles.

LEAF and e-NV200 – Nissan LEAF and e-NV200 offer a 5-year / 60,000 mile warranty on all EV dedicated components, including the lithium-ion battery, and a 3-year / 60,000 mile warranty on standard components. The Nissan LEAF and e-NV200 lithium-ion battery state of health guarantee protects against battery capacity loss (less than 9 bars out of 12) as shown on LEAF and e-NV200's capacity gauge for a period of 5 years / 60,000 miles. For LEAF and e-NV200 flex customers, the battery state of health guarantee applies for the duration of the battery lease.

FURTHER INFORMATION

Nissan European Roadside Assistance is provided for the period of your new vehicle manufacturer warranty.

Roadside, Recovery and At Home products are provided by RAC Motoring Services (Registered No. 1424399, Registered Office: 8 Surrey Street, Norwich, NR1 3NG). RAC Motoring Services (in respect of insurance mediation activities only) is authorised and regulated by the Financial Conduct Authority and within the jurisdiction of the Financial Ombudsman Service and Financial Services Compensation Scheme.

Onward Travel and European Cover are underwritten by RAC Insurance Limited (Registered No. 1424399, Registered Office: 8 Surrey Street, Norwich, NR1 3NG). RAC Insurance Limited is authorised and regulated by the Financial Conduct Authority and within the jurisdiction of the Financial Ombudsman Service and Financial Services Compensation Scheme.

Nissan EV Pan-European Roadside Assistance is provided by AXA for 3 years or 60,000 miles, whichever comes first.

For LEAF and e-NV200Flex (battery lease) customers, the Nissan EV Pan-European Roadside Assistance will cover you for the duration of your battery lease agreement should your Nissan EV run out of battery charge. For any other repair work, the basic warranty clause still applies.

Benefits and Services are provided by AXA Assistance. AXA Assistance is authorised and regulated by the Financial Conduct Authority (FCA).

FCA Register number 439069. AXA Assistance UK Limited (registration 2638890) 106 - 118 Station Road, Redhill Surrey RH1 1PR

Peace of mind – we always guarantee our workmanship, and all genuine Nissan replacement parts and accessories have a minimum of one year's warranty. Accessory prices are subject to change, please see your nearest dealership for the most up to date prices

Our technicians have been trained by Nissan to work on your vehicle and they are the Nissan specialists. They use the latest equipment to ensure your vehicle is given the best treatment. Accessory prices are subject to change, please see your nearest dealership for the most up to date prices.

Recyclability – we take all our environmental responsibilities very seriously - innovation today comes with a deep respect for the environment. Our engines are now much more unobtrusive and their emissions have been considerably reduced. All our vehicles are designed with recycling in mind.

Nissan Finance offers a wide range of flexible finance schemes to meet the needs of both our retail and business customers. Preferences, Hire Purchase, Nissan Contract Hire and Finance Lease, all offer the in-built flexibility to make the package tailor-made to meet your individual needs. We also provide added security to your finance agreement with a comprehensive range of payment protection plans. Ask your local Authorised Nissan Dealer for details.

The Nissan Motability Programme developed in association with the registered charity Motability enables those with difficulty getting around to obtain selected models on preferential terms.

All prices in this list are quoted in pounds sterling. Value Added Tax (VAT) has been calculated at 20%.

While all reasonable effort has been made to ensure the accuracy of the information provided, due to Nissan's policy of continuous product improvement, all particulars contained are subject to constant revision and Nissan reserves the right to change, alter or modify, among other things, specifications, colours and prices of models without notice at any time. Accordingly you should consult your local Authorised Nissan Dealer for the exact introduction dates of all models and for the most up-to-date information.

Images shown are for guidance purposes. In some instances photos are of non UK specification vehicles and do not represent a specific model, grade or offer.

OUR PROMISE. YOUR EXPERIENCE.



[REQUEST A TEST DRIVE](#)



There's no time limit on how long you will benefit from our promises. If you are a Nissan Customer, we will look after you.

That is our Promise.



FREE COURTESY CAR

YOU want to stay on the road when your Nissan is in for a service or repair.



FREE VIDEO HEALTH CHECK

YOU want to understand what is going on with your car's service.



SERVICE PRICE MATCH

YOU want the best value for money when it comes to service and repair.



CONTINUOUS ROADSIDE ASSISTANCE

YOU want the peace of mind you get from our quality service to go even further.



HERE FOR YOU

YOU want your problems resolved quickly.



TEST DRIVE YOUR CHOICE

YOU want to test drive the latest Nissan model, engine and gearbox you're interested in buying.

NISSAN PROMISE to keep you mobile free of charge whether you need a courtesy car, or just a lift

NISSAN PROMISE a free vehicle health check and we can even show you any work that might need doing with your own vehicle assessment video.

NISSAN PROMISE simple Fixed Price Servicing, and will price match like-for-like competitor written quotes within 10 miles of your local dealer.

NISSAN PROMISE to provide you with Roadside Assistance for free every time you service your car with us.

NISSAN PROMISE to propose a resolution to any problem within two working days.

NISSAN PROMISE that's what you'll get when you pre-book your test drive either online or through our customer service centre.

Just call 0330 123 1231.

Please visit nissan.co.uk/promise. Terms and conditions apply.

YOU + NISSAN
OUR PROMISE. YOUR EXPERIENCE.



NISSAN MOTOR (GB) LIMITED

The Rivers Office Park
Denham Way
Maple Cross
Rickmansworth
Hertfordshire
WD3 9YS

Visit our website at: www.nissan.co.uk

Part Number: 99999 54210

Prices effective from 1st October 2015 unless otherwise stated

Dealer stamp: