

The Peugeot **607**



# The 607 from Peugeot

## Reassuringly distinctive

Take a close look at the Peugeot 607. Every curve, every line, every feature, every comforting detail inside and out, has been created to meet the most exacting standards. This is a car that epitomises style and displays exceptional grace at every turn, with dynamic power, intelligence and immediate response combined to create the

ultimate in performance. The Peugeot 607 offers excellence on every level. A departure from the conventional and a statement that redefines driving pleasure. You can choose from 3 petrol engines: 2.0 litre (manual), 2.2 litre (manual and automatic) or 3.0 litre V6 (automatic). There are also 2 diesel engines: 2.0 litre

(manual) and 2.2 litre (automatic or our new 6 speed manual gearbox). With the choice of S or SE equipment as well, isn't it time you experienced the distinction of a 607?

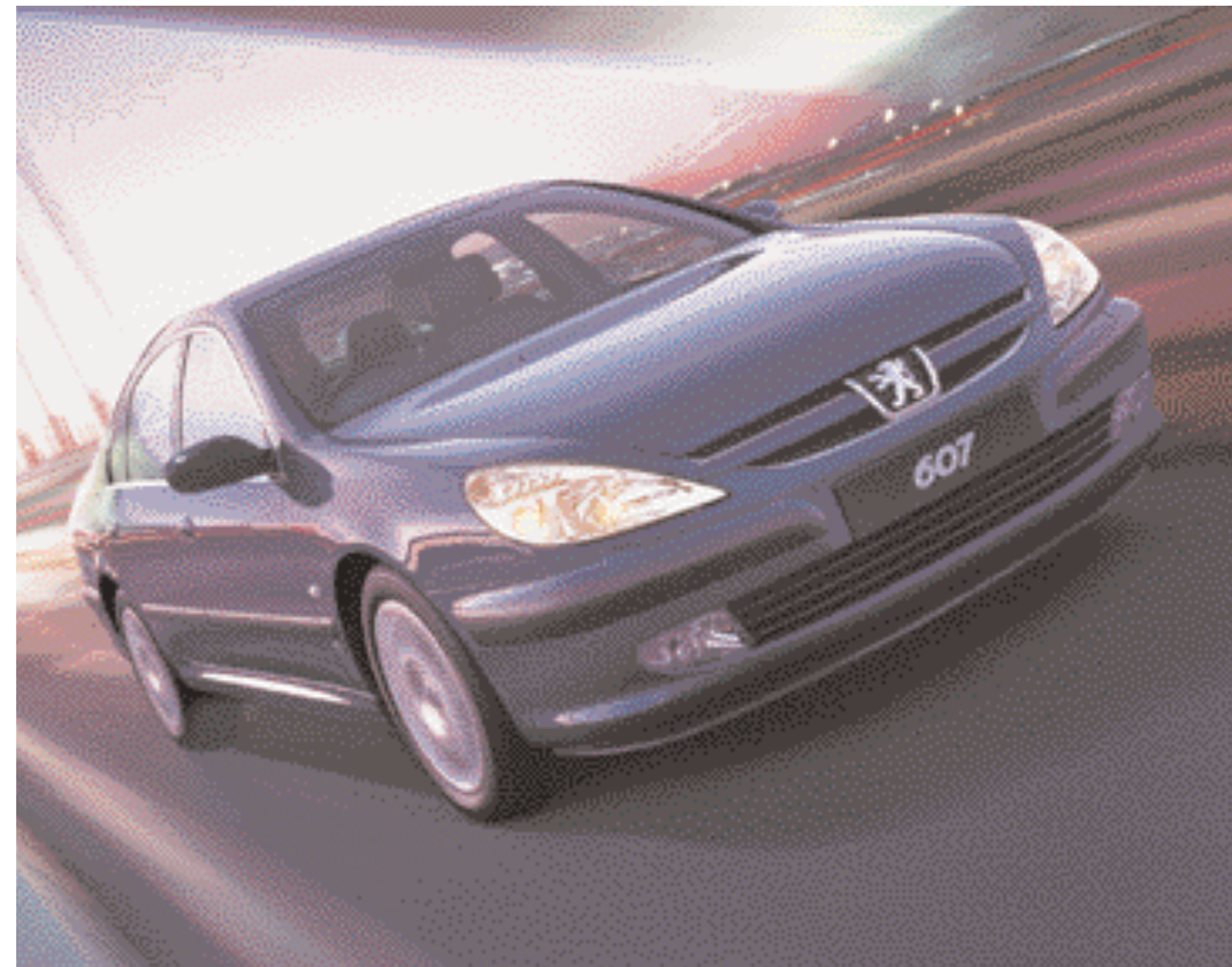





# Distinguished design

Sumptuous upholstery hides an intelligent driver's seat that recognises different signals from two separate remote control keys and adjusts accordingly (handy for two drivers sharing). In cold weather all occupants can enjoy the comfort of electrically heated seats.\*

\*Only available with leather interior trim.



The distinctive exterior of the Peugeot 607 is complemented by the equally stylish interior. New levels of comfort have been created, allowing driver and passengers to travel in a refined atmosphere as soothing as it is stimulating.

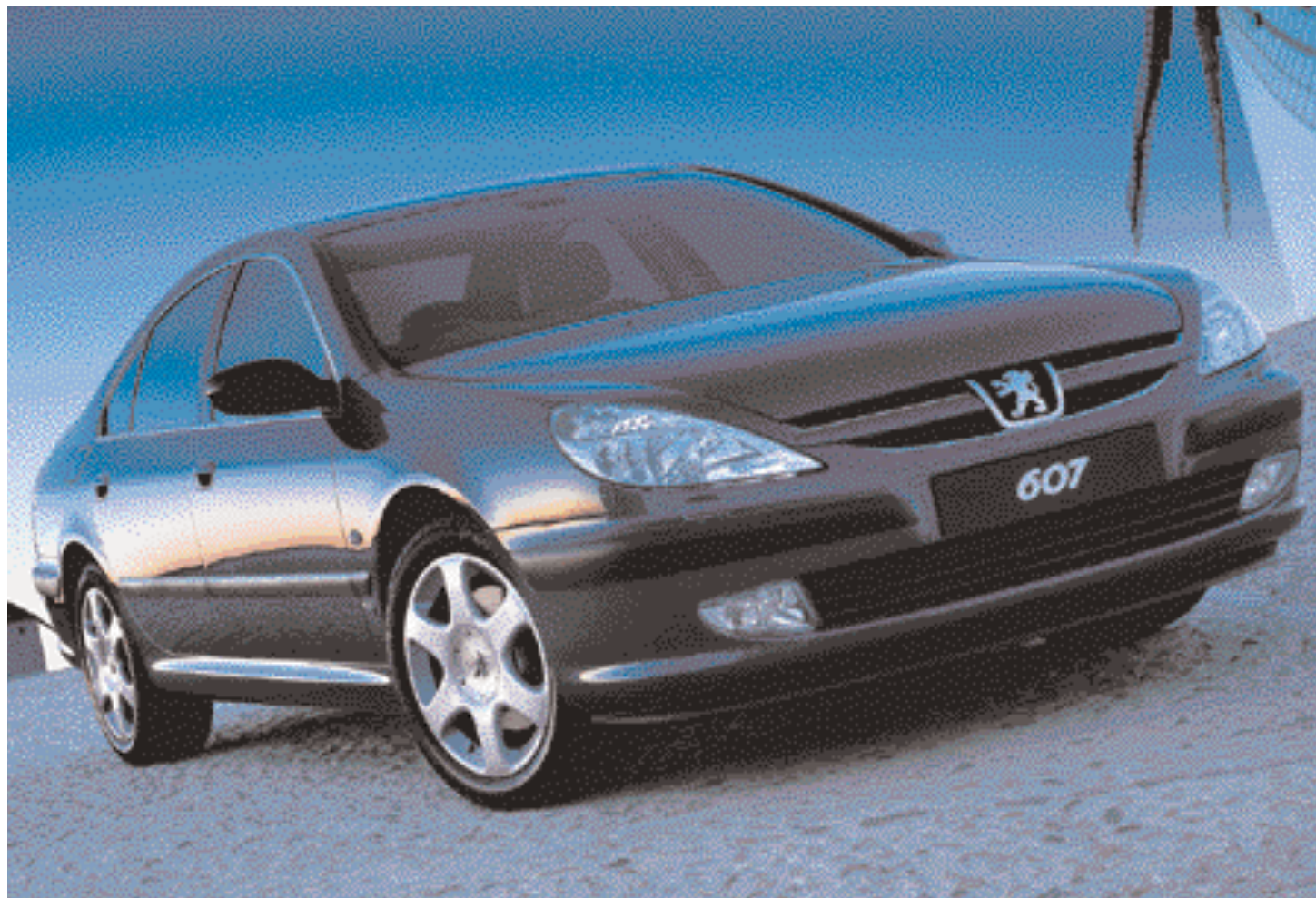

# Design for living

When does form override function? Thankfully, with the Peugeot 607, never. Every single detail has been considered to enhance and create an ambience that makes driving the 607 an experience that transcends the accepted boundaries of pleasure.



## Climate Control

The air conditioning system is linked to digital climate control. This ensures that the interior temperature is kept to the desired level, even if outside the conditions are constantly changing. For example, if you drive from bright sunshine into a tunnel, the temperature inside will remain constant.



## Light Sensitive Rear View Mirror

If someone comes up behind you at night and fails to dip their headlights, the rear view mirror will automatically dim them for you.

Standard on SE models.



## Electric Windows

Every Peugeot 607 features electric front and rear windows. These can also be centrally controlled and locked from the driver's position.



## Sunroof

The sunroof on the 607 is integrated into the roofline to create a seamless closure. It is opened and closed electronically by the driver.

Option at extra cost on SE models.



## Athermic Windscreen

In part, the coolness of the interior can be attributed to the Athermic windscreen. The titanium silver coating combined with thicker glass significantly reduces the transmission of energy into the cabin by filtering up to 25% of the sun's energy. This also provides long term protection for the interior fittings of the Peugeot 607.



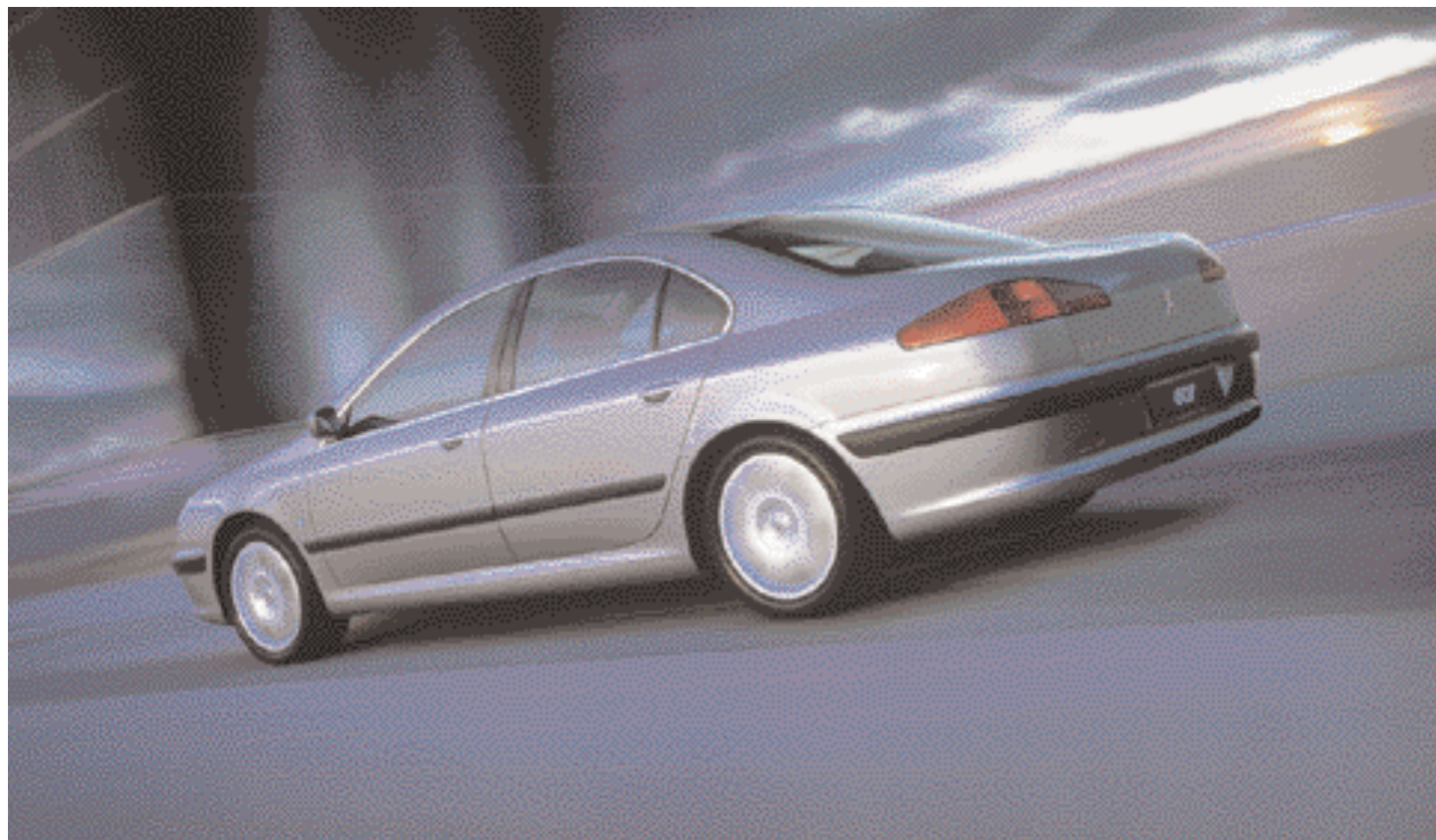

# Thinking smart

The Peugeot 607 has a wealth of technologically advanced features to ensure comfort for everyone on board, as well as providing impressive levels of safety and protection.



## Satellite Navigation

A navigation system with the latest graphics and processing technology is standard on the Peugeot SE models. It clearly displays maps in full colour to guide you to your destination. Push button controls also allow you to adjust the scale and positioning of the maps to suit your requirement. You can call up the display for the onboard trip computer as it continually updates useful information, such as fuel consumption, distance covered and remaining mileage to your destination. And once the serious business of navigation is over, the system allows you to plug in a video player/camera or DVD to provide video entertainment for your passengers.

Standard on SE models.  
Option at extra cost on all other models.



## Multiplex Wiring

The total length of wiring within a car has doubled over the last thirty years. However, with the advent of multiplexing, the number of connections has been reduced four-fold. It is a simple concept based upon streamlining circuitry via an Intelligent Control Module (BSI). This module collects data from the mechanical systems and distributes it to groups as opposed to sending infinitely more individual signals.



## Tiptronic Gearbox

Ease of response and effortlessly smooth gear changing are the hallmarks of the Tiptronic System Porsche Gearbox. In the automatic mode there are four conventional positions. However, selecting the fifth M position immediately allows you to change gears manually and the gearbox adjusts automatically giving a spontaneous change from effortless travel to sports performance. A further two selection buttons allow you to choose from electronically controlled Sport and Snow Programmes when in the automatic mode.

Standard on automatic models.

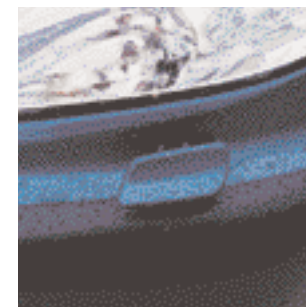

## Xenon Headlights

The subtle blue-tinted light from the Xenon headlights is produced by an electric arc suspended within Xenon gas. The result is a considerable increase in the level of illumination. The filaments produce a far more natural light than standard headlights, use 40% less power and last up to three times longer.

Standard on 3.0 V6 SE. Grouped option at extra cost on SE models.



## Parking Aid

Attention to detail is paramount in the Peugeot 607. Every consideration has been made to aid the driver as much as possible. When reversing, four ultrasonic sensors housed in the bumper trigger an audible warning as you close upon a fixed obstacle. Once the reverse gear is selected and a side indicator activated, the door mirror automatically adjusts itself to provide a clear view of the kerb.

Standard on SE models.

# Being smart

The Peugeot 607 features some remarkable technology designed not only to impress, but ensure that driving is as comfortable as it can be.



## Auto Rain Sensor

It can't predict the weather, but the Peugeot 607 can tell when it's raining. The windscreen wipers switch on automatically and the speed varies according to the intensity of rain. The 'Night Strategy' sensors then apply a higher wipe speed than during the day. Vehicle speed data also reduces the wiper speed automatically if the car slows to below 5mph.



## Low Tyre Pressure Sensor

An undetected reduction in tyre pressure caused by a slow leak can be dangerous and lead to excessive fuel consumption. Automatic sensors on the new Peugeot 607 provide audible and visual warnings should a reduction occur that's greater than 0.3 bar in relation to normal pressure.



## Integrated GSM Phone

The Peugeot 607's dashboard features style, common sense, functionality and even a radio with an integrated GSM phone.\* This is simply operated by the radio controls on the steering column or from the keypad on the centre console with the microphone discreetly hidden in the fascia. Should the need ever arise, this phone also provides a direct link to Peugeot's helpline via a dedicated button.

Standard on 3.0V6 SE. Option at extra cost on all other models. \* Not suitable for Orange or T-Mobile networks.



## Headlight Delay Security Illumination

The Peugeot 607 will not only get you home, but also see you to the front door. For example, when you are parking temporarily to open a garage door, the lights will remain on to serve as 'guidance' for 50 seconds. Then, once inside and you lock the car via remote control, the lights will automatically be turned off.



## Setting Suspension

The Peugeot 607 includes a new independent electronic suspension system with a range of advanced settings to suit different driving conditions.

You can change the suspension settings by merely pressing a button to select between 'locked' firm mode (sports) and flexible (comfort) mode.

In sports mode, body support and firmness becomes a priority with nine separate settings that can be chosen manually or automatically.

Then in non-sport mode, damping variants will automatically adjust to provide you with the most comfortable ride across a variety of driving surfaces.

Standard on 3.0V6 SE.

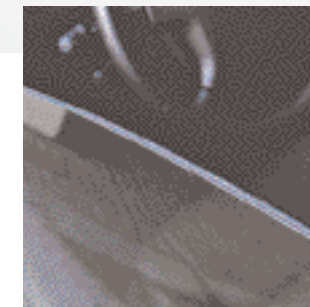

## Laminated Side Windows

At 5mm and made from toughened glass, the side windows are a millimetre thicker than on most other vehicles. This significantly reduces road noise as well as providing extra safety and increased protection against break-in.

Standard on SE models.

# For our protection

Once driven, you'll instinctively appreciate the Peugeot 607 as a particularly valuable asset. Reassurance and peace of mind are provided by an impressive combination of passive safety and active risk avoidance. Every feature thoroughly considered, well designed and assuredly reliable.



## Curtain Airbags

In the Peugeot 607, the comfort and safety of those around you is of paramount importance. Front airbags, as well as side chest airbags and 'curtain' airbags for both front and rear passengers, provide genuine peace of mind. The driver's airbag features controlled release vents and has a capacity of 60 litres, exceeding the European standard 45 litres by 33%. In the event of side impact, added protection is provided by the door structures which feature longitudinal reinforcing bars made from a double thickness shock-absorbing material.

Those who travel in the Peugeot 607 will discover a rare combination of overall intelligence with an abundance of common sense. For example, both front and rear seatbelts are fitted with pretensioners and force limiters to ensure safe restraint. Should you forget to fasten up, a reminder signal appears on the instrument panel display after the ignition is switched on.

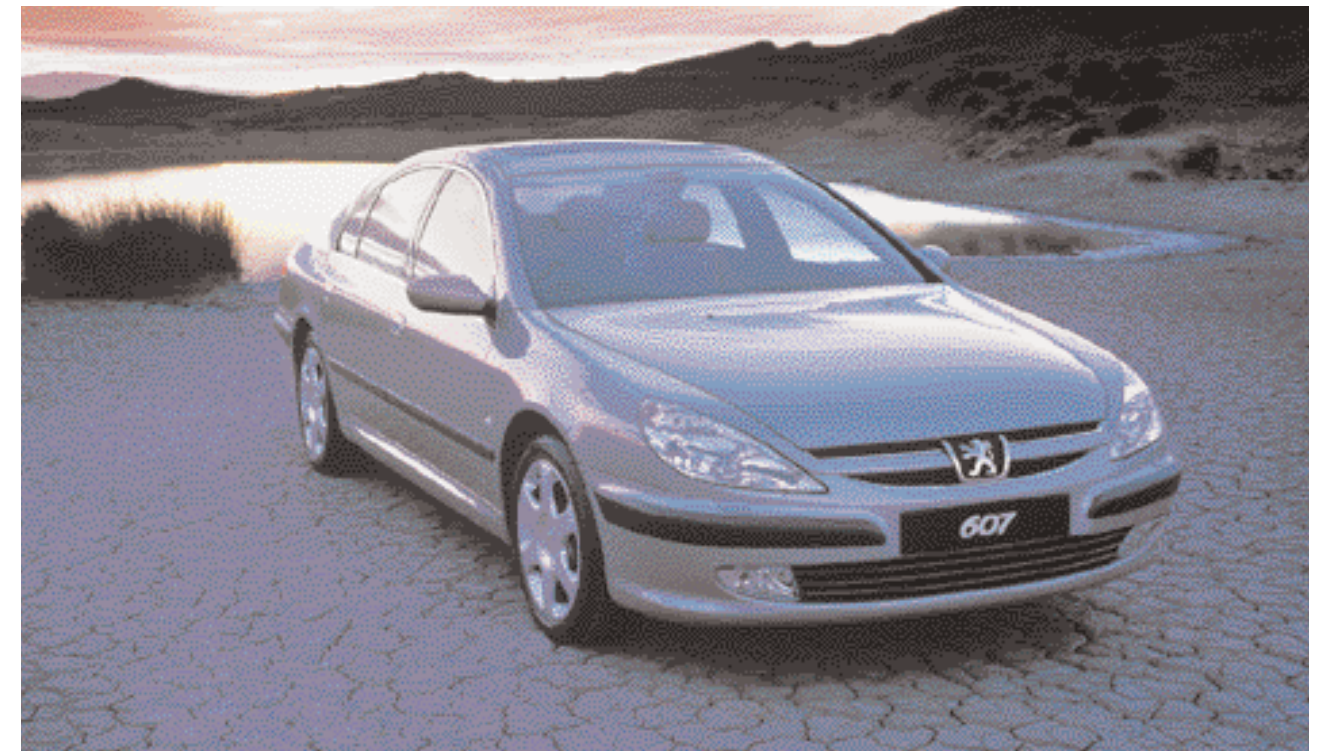

## Multifunction Key

Security is integral to the Peugeot 607. Two high frequency remote control keys are supplied with each 607 to function electric actuators on each door (locking, unlocking). These two HF remote control keys have four buttons, three of which are identified, with multiple functions.



## ESP

When faced with extreme driving conditions, safety is of the utmost importance. When making a sudden manoeuvre on a slippery road surface, control is essential. ESP (Electronic Stability Programme) combines a number of functions including traction control, dynamic stability control and ABS. When oversteer and understeer take place, the system creates a corrective torque, braking one or two wheels and modifying the engine torque. The system stabilises the vehicle under braking through shared front and rear response and it also limits the slip of the drive wheels to help maintain steering response.



## Auto Headlights

Never again be caught by fading light and forgetting to turn on your headlights. In the new Peugeot 607 a luminosity sensor (doubling as a sunlight sensor for the air conditioning system) will switch them on automatically. So as soon as the light fails, when weather dictates, night falls or even when entering a tunnel, you know you'll see and be seen.



# Clean machine

In today's society, it is comforting to know that the 607 has been designed with a shared responsibility in mind. Wherever possible, the materials are recyclable and other design features contribute to greater efficiency in fuel consumption\*. The result? A car available in a variety of colours, though still truly 'green' at its centre.

\*Please refer to the latest edition of the 607 specification leaflet.

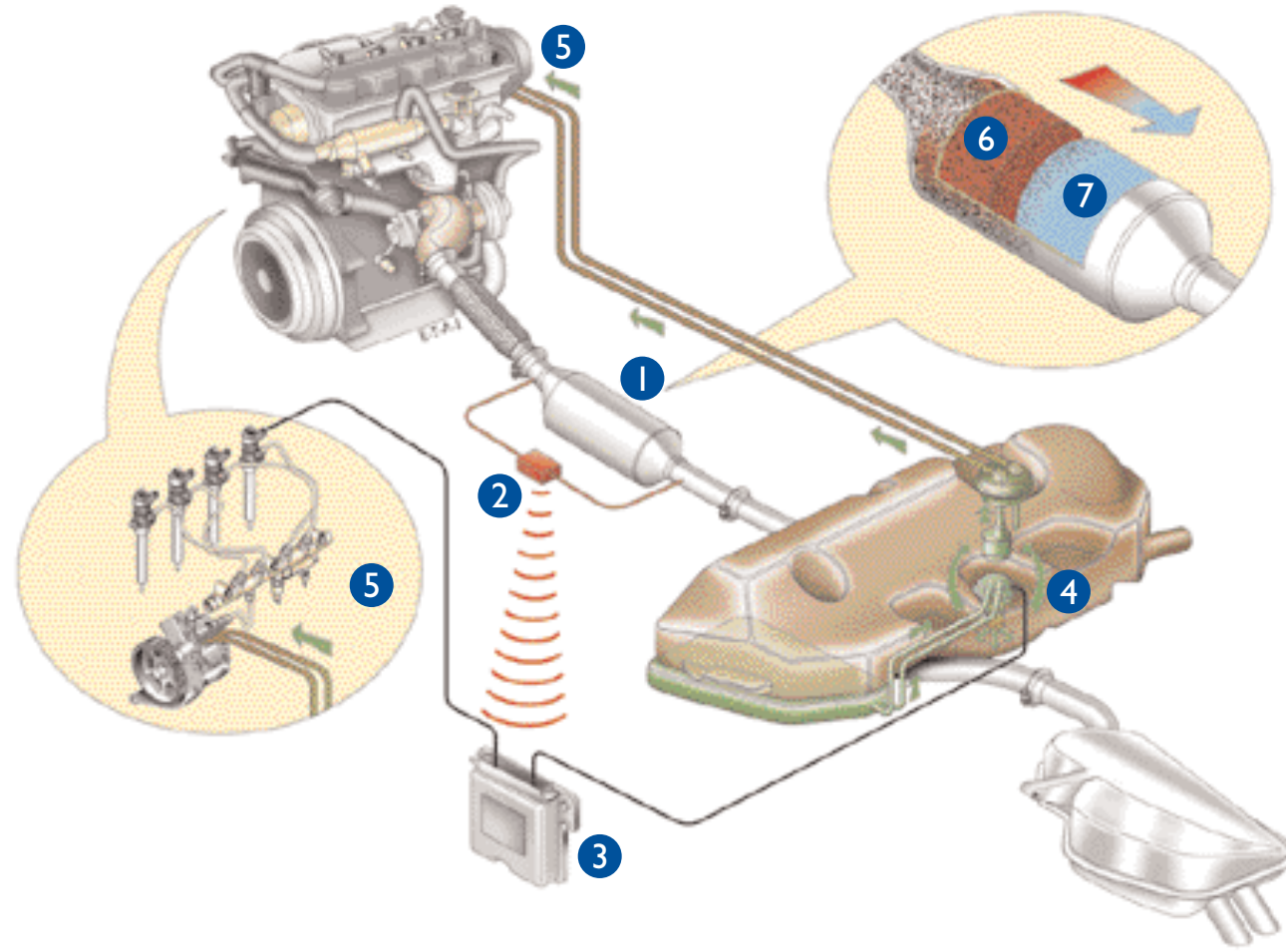

- 1 Filter assembly 'pre-catalyst and particulate filter'
- 2 Sensors
- 3 Engine management unit
- 4 Injection of additive into main diesel tank if necessary
- 5 Information specific to the injector when necessary for post-combustion
- 6 Precatalyst
- 7 Particulate filter (FAP)

The unique FAP filter has been developed by Peugeot and its porous silicon carbide construction allows the unhindered flow of exhaust gases to pass through while retaining pollutants such as soot and any other debris. Once the exhaust gas temperature exceeds 550°C, these potentially harmful residuals are harmlessly burned off.

Standard on 2.0 HDi and 2.2 HDi engines.



**HDi with Particulate Filter (FAP)**  
 One of the most environmentally sound developments featured in the 607 is the new particulate filter (FAP) system. This reduces pollution by virtually eliminating particulates and smoke. It operates under all conditions, constantly regenerating without affecting the drive.



# Colour & Trim

As with all works of art, the finishing touches make the difference between the good and the great. The Peugeot 607 is available in a range of stunning colours. You also have the choice of dashboard, instrument and carpet colour to create the car that is perfect for you.



Portofino Black cloth



Othello Grey velour



Astrakan Black leather



Oyster leather

Leather interior is an option at extra cost, except on the V6 SE model.



\*Metallic or pearlescent paint is an option at extra cost, except on the V6 SE model.

4 Colour  
to place

Bianca White

4 Colour  
to place

Monaco Blue\*

4 Colour  
to place

Oakland Green\*

4 Colour  
to place

China Blue\*

4 Colour  
to place

Mercury Grey\*

4 Colour  
to place

Moonstone\*

4 Colour  
to place

Vulcan Red\*

4 Colour  
to place

Dolomites Bronze\*

4 Colour  
to place

Onyx Black\*

# 607 Index

<b>A</b>		<b>M</b>	
Airbags	16	Multifunction Key	17
Athermic Windscreen	9	Multiplex Wiring	12
Auto Headlights	17		
Auto Rain Sensor	14	<b>N</b>	
		Nine Setting Suspension	15
<b>C</b>			
Climate Control	8	<b>P</b>	
Curtain Airbags	16	Parking Aid	13
Customer Promise	Opposite	Particulate Filter (FAP)	20/21
<b>E</b>		<b>S</b>	
Electric Windows	9	Satellite Navigation	12
Electronic Stability Programme (ESP)	17	Seat Memory	7
		Sunroof	9
<b>H</b>		<b>T</b>	
HDi	20/21	Technology	12/13/14/15
Headlight Delay Security Illumination	15	Tiptronic Gearbox	12
<b>I</b>		<b>X</b>	
Integrated GSM Phone	14	Xenon Headlights	13
<b>L</b>			
Laminated Side Windows	15		
Light Sensitive Rear View Mirror	8		
Low Tyre Pressure Sensor	14		

## The Peugeot Customer Promise

When you buy a new Peugeot vehicle from a Peugeot Dealer in the UK and entrust your vehicle to one of them for servicing or repair, they promise: to give you the best people, with the best training and diagnostic tools, Genuine Peugeot parts and the best aftersales backup, all at a competitive price.

## PEUGEOT PEACE OF MIND

Peugeot vehicles are designed and manufactured to give you worry-free motoring and peace of mind. As a Peugeot owner you are entitled to a comprehensive range of customer care services from your Peugeot Dealer who has the expertise to maintain your Peugeot to its peak performance.

## PEUGEOT WARRANTIES

### 3 Years of Warranty

In addition to the 2 year unlimited mileage manufacturer's Warranty, all vehicles first registered in the UK and purchased from a UK Peugeot Dealer benefit from a free optional additional 1 year of Warranty provided by the Peugeot Dealer network in the UK. This optional Warranty is offered free of charge but subject to the manufacturer's recommended servicing being carried out by an authorised Peugeot Dealership. This additional Warranty carries a mileage limit of 60,000 miles (100,000 miles for Boxer models excluding Motorhomes and other converted vehicles) from first registration. The conditions of the additional 1 year Warranty are identical to those of the 2 year manufacturer's Warranty. (For full terms and conditions, please consult your Peugeot Dealer). NB: This 3 years of Warranty is automatically transferable on the sale of the vehicle).

### 12 Year Anti-Perforation and 3 Year Paint Warranty

Also automatically transferable on sale of the vehicle, this will maintain and enhance the resale value of your vehicle. (The Anti-Perforation Warranty is limited to 6 years and the Paint Warranty to 2 years on 206 Van, Partner, Expert and Boxer vans).

## PEUGEOT EXTENDED WARRANTY

Should you need protection beyond the initial 3 years of Warranty, the Peugeot Extended Warranty plan can give you cover of up to 120,000 miles or 4 to 5 years on cars, or 4 years with unlimited mileage on Partner, Expert, Expert Combi and Boxer vans. Available as an option at extra cost, the Peugeot Extended Warranty is one of the most competitive schemes of its type and is available exclusively to Peugeot owners. Please ask your Dealer for full details.

## PEUGEOT ASSISTANCE

For the first year of ownership you will automatically receive Peugeot Assistance cover for complete peace of mind. Additional Peugeot Assistance may be purchased for the second and third years. Operated by the RAC, it includes roadside assistance, vehicle recovery, free replacement vehicle or hotel accommodation and chauffeur provision in case of certain medical disabilities. Peugeot Assistance is available within the UK and Europe. Your local Peugeot Dealer has full details of terms and conditions.

## PEUGEOT SERVICE CARE

Peugeot petrol engine vehicles need servicing every 20,000 miles or every 2 years, whichever is sooner. Drivers of diesel versions also benefit from extended servicing with 12,000 miles (10,000 non HDi diesel vehicles) or 2 year intervals. With less time spent in the maintenance bay and fewer service visits, Peugeot have passed on the benefits of technology in engine design and lubrication. Cost savings, compared to competitive models, increase with mileage covered, and could be up to 45%.

In order to minimise the inconvenience associated with normal servicing, Peugeot UK Dealers promise to offer you the choice of:

- while you wait servicing with a timed appointment;
- or local vehicle collection from your home or place of work;
- or alternative transport to the railway station, home or place of work;
- or by arrangement, a hire vehicle at a concessionary rate.

In addition they will aim to ensure that your vehicle is washed before it is returned.

## PEUGEOT INSURANCE CENTRE

Peugeot Insurance has been specifically arranged for Peugeot owners. Offering discounted premiums and a fast and efficient claims service, it is another benefit of owning a Peugeot. Your Dealer can provide a proposal form for a free quotation or you can call the Peugeot Insurance Centre direct on 0845 200 1234 for a free quotation. Alternatively, contact:

**Peugeot Insurance Centre**  
**The Wharf**  
**Neville Street**  
**Leeds**  
**LS1 4AZ**

Whatever Peugeot you drive, we guarantee you a competitive premium for your Motor Insurance. As a valued customer of Peugeot we'll make sure you get the very best premium quotation possible from Peugeot Insurance.

The information and images in this brochure are based on the current technical data when going to print. The equipment shown is factory fitted or available as an option at extra cost, depending on the model. Where a feature is described as an option it should be assumed that it is at extra cost unless specifically stated otherwise. There may be some feature combinations that are not available in the UK and some photography may feature left hand drive vehicles. As part of a policy of continuous specification improvement, Peugeot reserve the right to modify the technical equipment, options and colours at any time. For full specification details please refer to the specification leaflet or ask your Peugeot Dealer who will be happy to help. Note that current print and photographic techniques do not allow us to faithfully reproduce the full depth and tone of the colours in this brochure. This brochure is designed to provide general product information and is not a contractual document or offer of sale. For current information please contact your authorised Peugeot Dealer. The details in this catalogue cannot be reproduced without the express authorisation of Peugeot.



Issued by: Sales and Marketing, Peugeot Motor Company plc,  
Aldermoor House, PO Box 227, Aldermoor Lane, Coventry CV3 1LT.

For details of HM Forces tax-free military sales contact:  
Peugeot Export, 454-490 Mile End Road, London E1 4PE.  
Telephone: 0207 791 9050  
Email: [peugeot.export@peugeotmail.co.uk](mailto:peugeot.export@peugeotmail.co.uk)

For all other enquiries please call 0845 200 1234  
(calls will be charged at local rate, and may be recorded  
for training or quality purposes).

**[www.peugeot.co.uk](http://www.peugeot.co.uk)**

July 2003  
MCP 2087

