

J



U



S



T



Y



5 - speed Manual or ECVT Automatic 4WD.



T H E W O R L D ' S F A V O U R I T E F O U R - W H E E L D R I V E .

S U B A R U . T H E W O R L D ' S F A V O U R I T E  
F O U R - W H E E L D R I V E .



The Subaru Justy hatchback brings a whole new meaning to supermini motoring. With its push button on-demand four-wheel drive and a choice of 5-speed manual or ECVT automatic transmission, it's just about the most versatile small car you could buy.

Four-wheel drive was once the sole preserve of the cross country vehicle. Helping farmers to reach outlying areas of land safely. Then Subaru four-wheel drive brought the benefit of optimum traction to many more motorists. But even if you never drive in off-road conditions, you'll find that the Subaru 4WD Justy has a great deal to offer.

The self-assured roadholding of the world's favourite four-wheel drives. Much more traction when you're driving in the frost, ice and snow of winter - or at high speeds, on wet roads, or rough surfaces at any time of year.

So wherever the road, whatever the conditions, Justy will get you where you want to go. In style and comfort, with the added traction of four-wheel drive.

And if you live on the hill, the Justy gives you improved grip. Where a two-wheel drive car often gives you only wheelspin, Justy takes you to the top.



*Whatever the weather...*



*... wherever the road uphill or downhill...*



*... Subaru 4WD. Gripping Stuff.*



*The business  
in town...*



*... a pleasure  
in the country.*

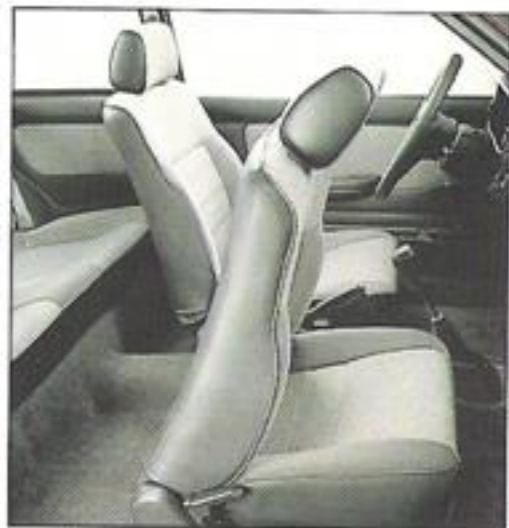

*The wide hatch opens from the bumper to take the strain out of loading.*



The Subaru Justy is a rather special car inside, too.

Whether you choose the 5-door GLII, the 3-door SII, manual or ECVT automatic, you'll find that the Justy is an impeccable example of good design that makes the most of available space.

Although compact in size, at a little over 12 feet long, it has a surprising amount of space for passengers to travel in civilised comfort.



And with lots of handy storage compartments, the Subaru Justy stays free from clutter.

Split rear seats are standard. So you can carry long objects even with a passenger in the back. And if you need to carry really big loads, you can fold down both rear seats to give a huge 21.4 cu ft of luggage space.

Which makes the Justy as versatile on the inside as it is on the road.



*Space versatility  
- for work and play.*



*Folding seats mean more flexibility.*



*Space for the  
family...*



*... pace for  
the sporty.*



*Surefooted and agile  
where others fear to tread.*

SUBARU 4WD. Country Life depends on it.



Thanks to Subaru's high technology aerospace background, the Justy has advanced engineering built into its engine, transmission systems and overall design.

Which is one reason why more than two and a half million Subaru 4WD vehicles have been built during the past two decades. And why Subaru has consistently ranked among the world's most reliable makes.



*Classical performance  
- all year round.*

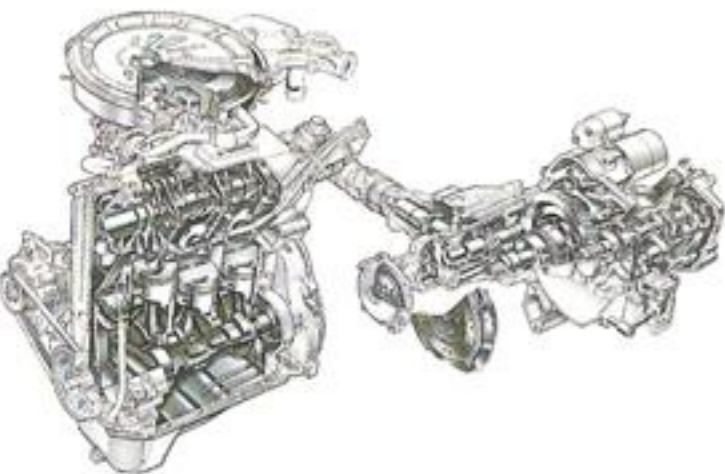

Lively 1.2 litre engine.

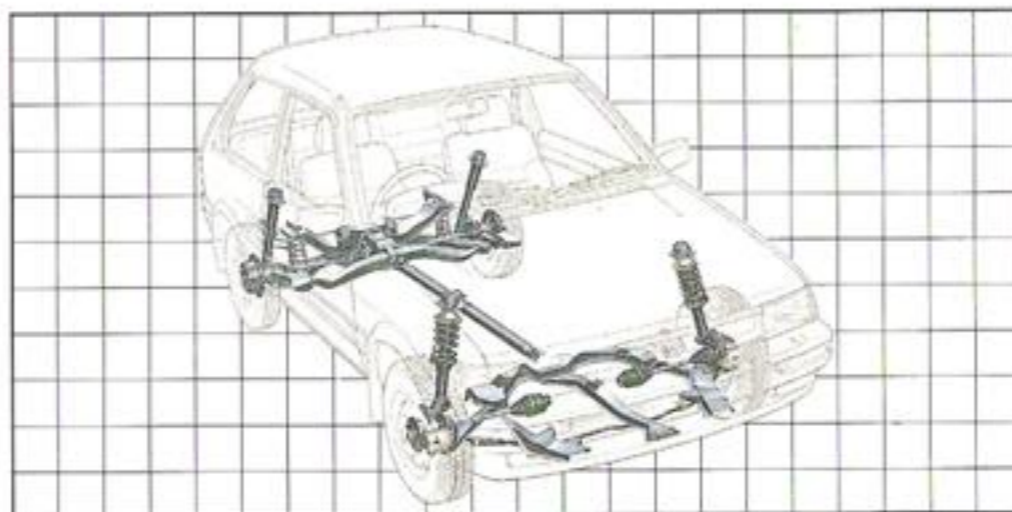

When you take the Subaru Justy out on the road you'll soon find out why it's so successful. The responsive 1.2 litre engine, 5-speed manual or ECVT automatic transmission and selectable four-wheel drive make the Justy a really lively performer.



The engine has three cylinders, each with three valves, a recessed piston design, and overhead camshaft. It produces 67 bhp, giving crisp acceleration and brisk performance on unleaded or leaded fuel, without modification.

Rack and pinion steering gives firm, position handling. And all-round independent suspension ensures a smooth, comfortable ride under all road conditions. Variable ratio steering reduces effort, making parking easier and providing improved control.

On wet or icy roads, on greasy bends or steep climbs, press the button on the gear lever and you're in the grip of Subaru four-wheel drive, delivering power to all four wheels. And giving you added confidence just when you need it.

Press the button once again and you're back in front-wheel drive. Just as simply. So you'll handle all those essential journeys in bad weather conditions like a dream. Not a nightmare.



Transistorised ignition and autochoke.  
- For a surefire getaway.



13" radials and ventilated front disc brakes.  
Positive stopping power.



Ventilated front disc brakes.

Variable gear ratio rack & pinion steering.



All current Subaru vehicles run on unleaded or leaded fuel without conversion.

## SUBARU 4WD JUSTY.

Now with Electro-Continuously Variable Transmission.



Shift positions of ECVT are as simple as those of an ordinary automatic transmission.



The shift position selected is displayed by the indicator on the instrument panel, for added convenience.

Continuously variable transmission is a car designer's dream. A dream as old as the very first car.

In the past, attempts have been made to build such a transmission with many different means of delivering engine torque to the wheels. Rubber belts, contracting discs; all have been tried.

A major problem was that durable materials just weren't available, with the result that early attempts to introduce continuously variable transmission enjoyed only limited success.

But now, with Subaru ECVT Automatic, all that has changed.

ECVT, or Electro-Continuously Variable Transmission, is a new technological breakthrough. It dramatically boosts performance compared with conventional automatic transmissions.

Because there are no gears *in the accepted sense*, stops and starts are smoother than ever before. It provides smooth, stepless 'gear-changing' and fast acceleration at all speeds without the time-lag of conventional automatic transmissions.

Subaru ECVT is the world's first continuously variable transmission of its kind to be fitted to a production car.

It uses a special steel belt and a system of two pulleys. The groove widths between both halves of these pulleys widen or narrow in inverse proportion to each other. So the steel belt sinks to the centre of the pulleys or rises to their rims, providing, continuous, stepless progress from low to high ratio and vice versa.

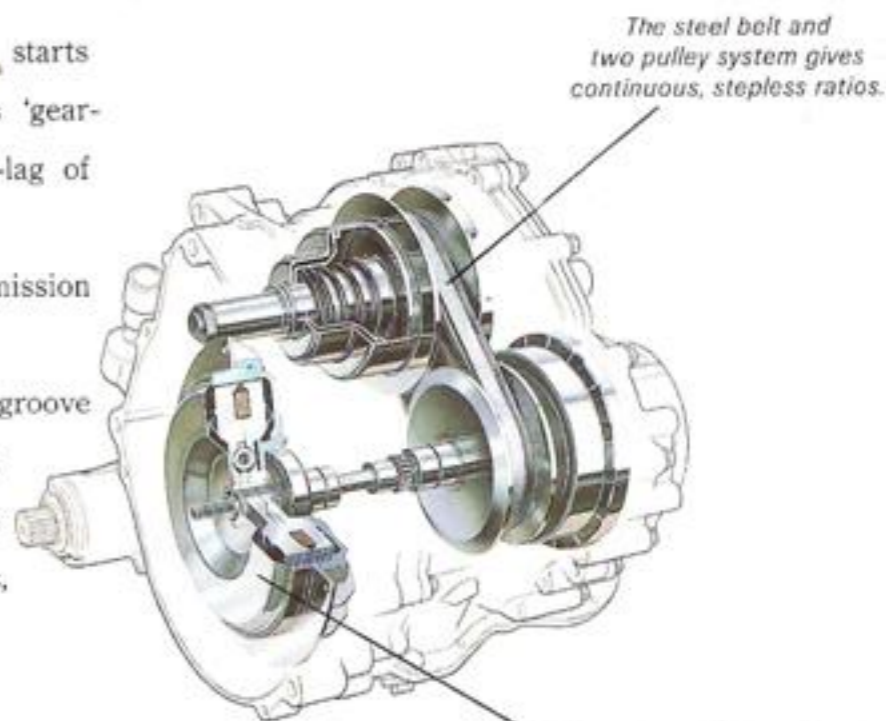

The steel belt and two pulley system gives continuous, stepless ratios.

The unique Subaru electromagnetic powder clutch controls engine torque to the transmission.

## JUSTY 4WD WITH ECVT AUTOMATIC -

The ideal transmission system for all kinds of road.

Engine torque to the transmission system is controlled by a unique electromagnetic powder clutch monitored by a microcomputer.

And you can select the Ds position for even more acceleration, power and performance. But all this is only part of the story. The Subaru Justy combines, for the very first time, the advantages of ECVT with the benefits of 4WD.

This unique combination provides highly responsive acceleration and deceleration together with outstanding control and stability. The result is surefooted roadholding performance and a more exhilarating driving experience.

ECVT control is just as simple as a conventional automatic transmission, and 4WD is switched in and out at the touch of a button.

Subaru Justy with ECVT and 4WD. A major step forward in sure, safe, automatic motoring.

**Uphill roads.** The car climbs easily by simply depressing the accelerator pedal without requiring any shifting operation. If the slope is more than moderately steep, 4WD will provide even more traction.

**Motorways.** When cruising on the motorway, the "D" mode maximises fuel economy, with exceptional quietness and comfort. 4WD ensures greater safety and stability.

**Ordinary roads.** From starting to high speeds, the "D" range covers all driving situations, delivering exceptionally responsive manoeuvrability and greater fuel economy.

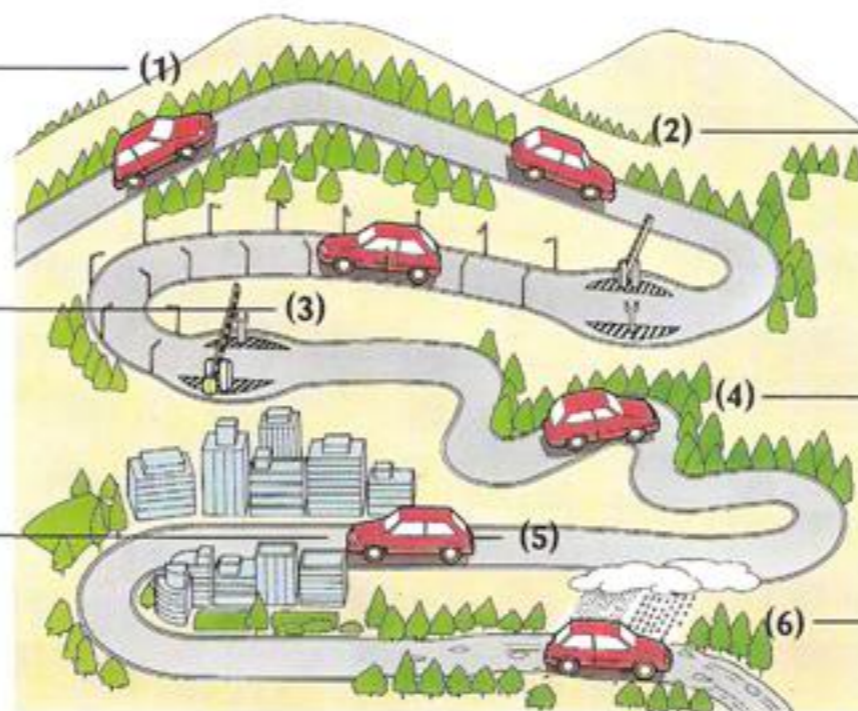

**Long, downhill roads.** As vehicle speed lowers, the ECVT ratio automatically and steplessly shifts toward the "low" range, providing effective engine braking. Select "Ds" range to achieve maximum engine braking performance.

**Winding roads.** For maximum acceleration and powerful engine braking, set the shift lever to the "Ds" range and you can fully utilise the engine power by keeping engine revolution at or above 3,000 rpm. You can always remain in "D" mode for a more leisurely drive.

**Slippery and rough roads.** Since ECVT assures extra-smooth starts, wheel skidding on slippery roads seldom occurs. Selecting the 4WD mode further enhances vehicle tractability.



*Responsive obedience -  
- a standard feature.*

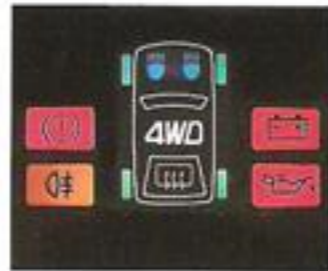

Sit behind the wheel of a Subaru Justy and you're comfortably in control with everything you need close to hand.

Lights, signals and wash-wipe are all controlled by levers on either side of the steering wheel. And all other switches are at your fingertips on the logically designed fascia.

The big, easy-to-read instrument panel, graphic monitor and digital clock are specially designed to give you information at a glance.



Inside the Justy, driver and passengers are cosseted in superb comfort.



Reclining front seats are standard, and all seats are ergonomically contoured. So you arrive at your destination feeling fresh, even after a long journey.

Colour co-ordinated cloth upholstery and pile carpets complete the feeling of luxury, and even the boot floor is fully carpeted.



Fully adjustable -  
- wonderfully comfortable.



EXTRA! EXTRA!



Full wheel covers enhance the Justy's sporty looks.



Door pockets keep the Justy free from clutter.



Heated rear window for clear visibility - fast.



Centre console for things you'll need on your journey.



Rear wash-wipe keeps the rear window clean in dirty weather.



Childproof locks keep your most precious cargo safe.\*

It's the thoughtful extras that make all the difference to motoring pleasure.

With most cars they're just that. Extra. But with the Subaru Justy they come as standard.

Which is just one more reason why the Subaru Justy is a rather special car.

JUSTY: 3-door and 5-door specifications.

| Item   | GL II<br>5-door   | SII<br>3-door | Item  | GL II<br>5-door                          | SII<br>3-door   |          |
|--|-------------------|---------------|---|--|---|----------|
| <b>Interior</b>                                      |                   |               | <b>DIMENSIONS &amp; WEIGHT</b>                    | Overall length                           | mm (in) 3695 (145.5)  |          |
| Day/night rearview mirror                            | ○                 | ○             |   | Overall width                            | mm (in) 1535 (60.4)   |          |
| Vanity mirror  | ○                 | ○             |   | Overall height                           | mm (in) 1420 (55.9)   |          |
| Inside back door lock release                        | ○                 | ○             |   | Wheelbase                                | mm (in) 2285 (90.3)   |          |
| Manual remote-control door mirrors                   | ○                 | ○             |   | Front                                    | mm (in) 1330 (52.4)   |          |
| Auto choke   | ○                 | ○             |   | Rear                                     | mm (in) 1290 (50.8)   |          |
| Front stabiliser                                     | ○                 | ○             |   | Ground clearance (laden)                 | mm (in) 105 (4.1)   |          |
| Rear stabiliser                                      | ○                 | ○             |   | Kerb weight (unladen)                    | kg (lb) 855 (1885) 840 (1852)                                     |          |
| Front ventilated disc brakes                         | ○                 | ○             |   | ECVT Kerb weight (unladen)               | kg (lb) 875 (1929) 860 (1896)                                     |          |
| Digital clock  | ○                 | ○             |   | Towing Braked                            | kg (lb) 800 (1763) 800 (1763)                                     |          |
| Door pocket (driver's side)                          | ○                 | ○             | <b>ENGINE</b>                                     | Type                                     | Liquid-cooled, 3-cylinder, 4-stroke, DHC gasoline engine          |          |
| Door pocket (front passenger's side)                 | ○                 | ○             |   | Bore x stroke                            | mm (in) 78.0 x 83.0 (3.071 x 3.268)                               |          |
| Rear quarter pocket (right-hand)                     | ○                 | ○             |   | Displacement                             | cc (cu. in) 1,180 (72.53)   |          |
| Front inertia-reel seat belts                        | ○                 | ○             |   | Compression ratio                        | 9:1   |          |
| Rear inertia-reel seat belts (2) and static lap belt | ○                 | ○             |   | Carburettor                              | Two-barrel, down draught type                                     |          |
| 2 Speed/Intermittent wiper and washer                | ○                 | ○             | <b>PERFORMANCE</b>                                | Fuel tank capacity lit. (US gal/imp gal) | 35 (9.2/7.7)  |          |
| Rear window wiper and washer                         | ○                 | ○             |   | Max. output (DIN)                        | kW (PS)/rpm 50 (68)/5,800 (SAE BHP: 6705)                         |          |
| Adjustable front seat head restraints                | ○                 | ○             |   | Max. torque (DIN)                        | N-m (kg-m)/rpm 87 (0.9)/3,600                                     |          |
| Rear door child safety locks                         | ○                 | ○             | <b>ELECTRICAL SYSTEM</b>                          | Battery                                  | V-AH 32V-36AH   |          |
| 3-spoke steering wheel                               | ○                 | ○             |   | Alternator                               | V-A Manual 12V-50A ECVT 12V-55A                                   |          |
| Variable gear ratio steering                         | ○                 | ○             | <b>TRANSAXLE</b>                                  | Clutch                                   | Dry single plate diaphragm type OR Electromagnetic powder         |          |
| Tachometer   | ○                 | ○             |   | Transmission type                        | 5 forward speeds with synchromesh and 1 reverse OR ECVT Automatic |          |
| Rear ashtray   | ○                 | ○             |   | Gear ratio                               | 1st   | 3.071    |
| Heated rear window                                   | ○                 | ○             |   |  | 2nd   | 1.695    |
| Split fold-down rear seat                            | ○                 | ○             |   |  | 3rd   | 1.137    |
| Rear luggage shelf                                   | ○                 | ○             |   |  | 4th   | 0.794    |
| Luggage space light                                  | ○                 | ○             |   |  | 5th   | 0.675    |
| Vinyl/cloth door trim                                | ○                 | ○             |   |  | Reverse   | 2.475    |
| <b>Exterior</b>                                      |                   |               |   | Final reduction gear ratio               | 5.209   | 4.066    |
|  | Blue tinted glass | ○             |   | ○  | <b>CHASSIS</b>  | Steering |
| Radio antenna  | ○                 | ○             | Suspension  | Front McPherson strut type, independent  |   |          |
| Halogen headlights                                   | ○                 | ○             | Rear Wishbone/coil, independent                   |  |   |          |
| Front mud flaps                                      | ○                 | ○             | Min. turning circle (wall to wall)                | m (ft) 9.8 (32.2)                        |   |          |
| Rear mud flaps                                       | ○                 | ○             | Min. turning circle (at outer front wheel centre) | m (ft) 9.0 (29.5)                        |   |          |
| 165/65R13 radial tyres                               | ○                 | ○             | Brakes  | Front Ventilated disc brakes             |   |          |
| Side protector stripes                               | ○                 | ○             | Rear Drum brakes (leading and trailing)           |  |   |          |
| Coloured front grille                                | ○                 | ○             | Tyres   | 165/65R13                                |   |          |
| Full wheel covers                                    | ○                 | ○             |   |  |   |          |

Technical data and equipment are based on the latest information available at the time of printing. Subaru (UK) Limited reserve the right to make changes at any time, without notice, in colours, materials, design, equipment and specifications and to discontinue models. Customers are advised to consult their Subaru Dealer on the precise details of vehicles available for sale. Models specified are strictly subject to availability. Subaru vehicles are covered by 12 months unlimited mileage warranty with a total of 28 months for engine, transmission and driveline components (excluding Dutch driven plate). Bodywork is covered by a 6 year anti-corrosion warranty. Please consult your Subaru Dealer for full details. Owing to the limitations of printing processes, the colours reproduced may not exactly match product colours.

Take a close look at the Justy's vital statistics. Check them against other cars in its class and price range and you'll find there's no comparison.

But of course, to appreciate fully the finer points of this rather special car you'll need a test drive. So what are you waiting for?



Subaru Justy.  
Check the facts.

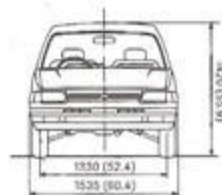

5-Door

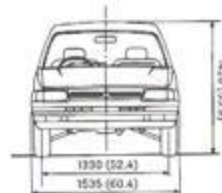
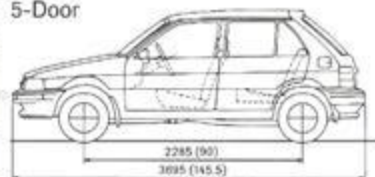

3-Door

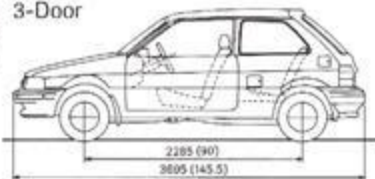

DIMENSIONS mm (in)



*Justy 1.2 4WD GLII 5-door.*



*Justy 1.2 4WD SII 3-door.*



Subaru (UK) Limited, Ryder Street, West Bromwich, West Midlands, B70 0EJ. Tel: 021-522 2000. A subsidiary company of I.M. Group Limited.

Designed and produced by Barkers, Birmingham.

October 1989. Part No. SB031.