

1982 Mazda RX-7

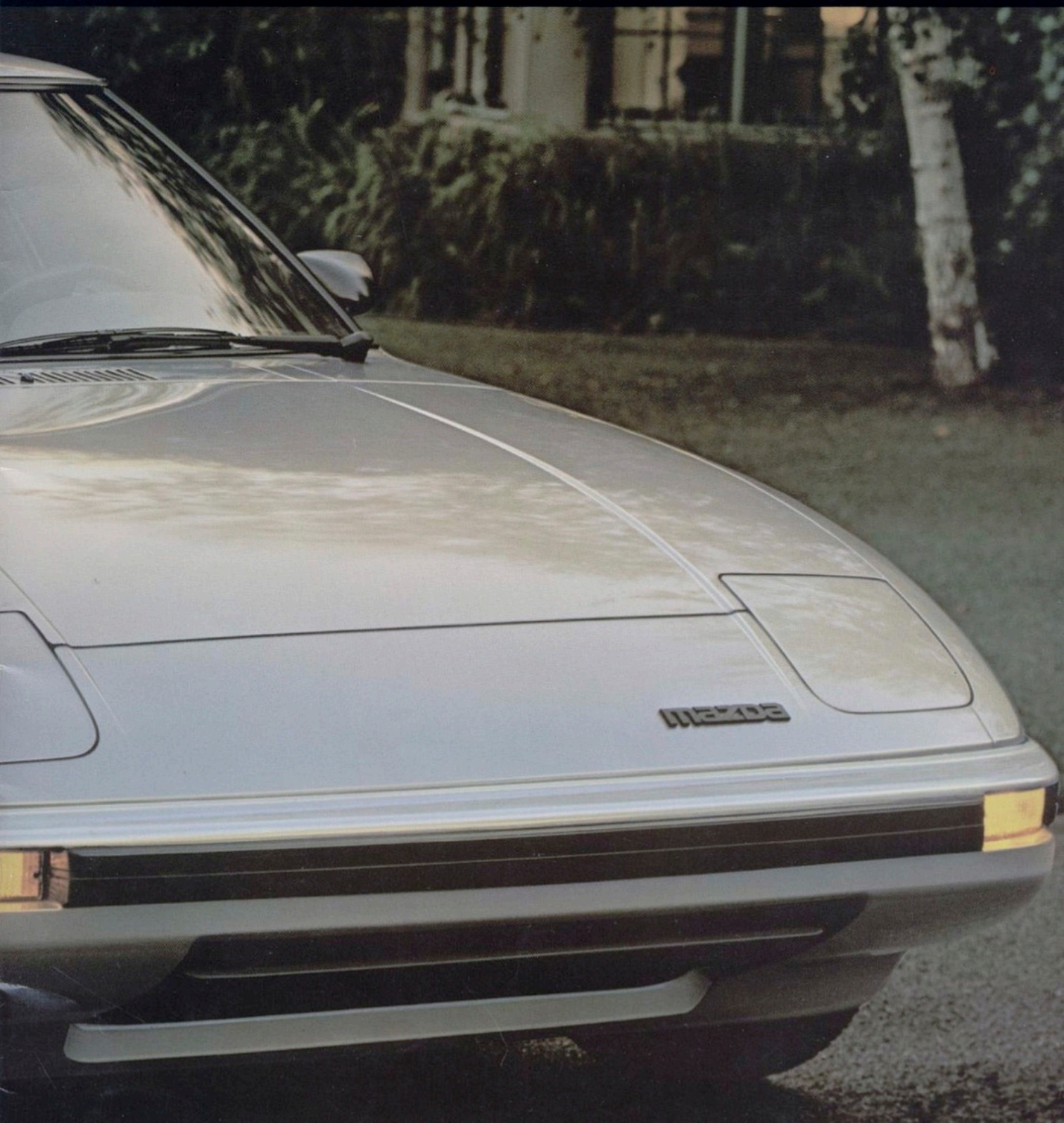

When Mazda introduced the RX-7, Road & Track called it "An enthusiast's dream come true." With good reason.

It was in the spring of 1978 that the new RX-7 entered the rarified atmosphere of high-performance sports cars. And America's reaction was instant and incredulous.

RX-7 had all the credentials of a bonafide sports car. Sophisticated high-performance engineering. A twin-rotor engine that could rocket it from 0 to 60 in 8.7 seconds. A sleek, slippery look outside, business-

like instrumentation inside, and a pair of proper bucket seats.

It was a machine enthusiasts would lust for at any price—yet the price was modest enough to make RX-7 indeed an enthusiast's dream come true.

Instant recognition. Automotive press and public alike celebrated RX-7's arrival with high tribute. *Road & Track* named it one of the "Ten Best Cars for a

Changed World" in 1978. *Road Test Magazine* in January named it the "Outstanding Sports Car of 1979." And in *Car and Driver* magazine's *Reader's Choice*

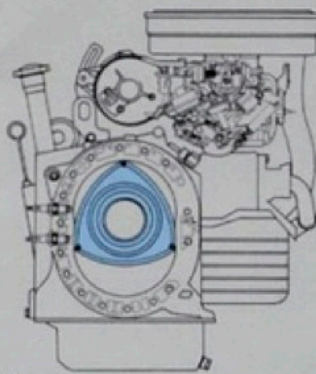

The rotary engine—key to RX-7's spectacular performance.

Poll Awards, it was voted "The Most Significant New Imported Car of 1979." Instant Classic had arrived. **The stern tests of the track.** Meanwhile, Mazda engineers and racing team drivers turned to competition to learn how their machine would fare in head-to-head showdowns.

RX-7's track debut was one of the sternest tests of all: the 24 Hours of Daytona, 1979. Of 68 cars that started, 46 failed to finish. But two factory-modified RX-7's did finish—1st and 2nd in the GTU (Grand Touring under 2.5 litre) Class, 5th and 6th

Electric remote-controlled fuel filler door—one of many 1981 improvements.

Reclining, orthopedically-contoured highback bucket seats with good lateral support.

Five speed overdrive transmission standard. Shifter repositioned 4 inches closer in 1981 for easier reach, quicker shifting.

Rear suspension: live axle, 4-link type, Watt linkage and coil springs, for excellent handling without a harsh ride.

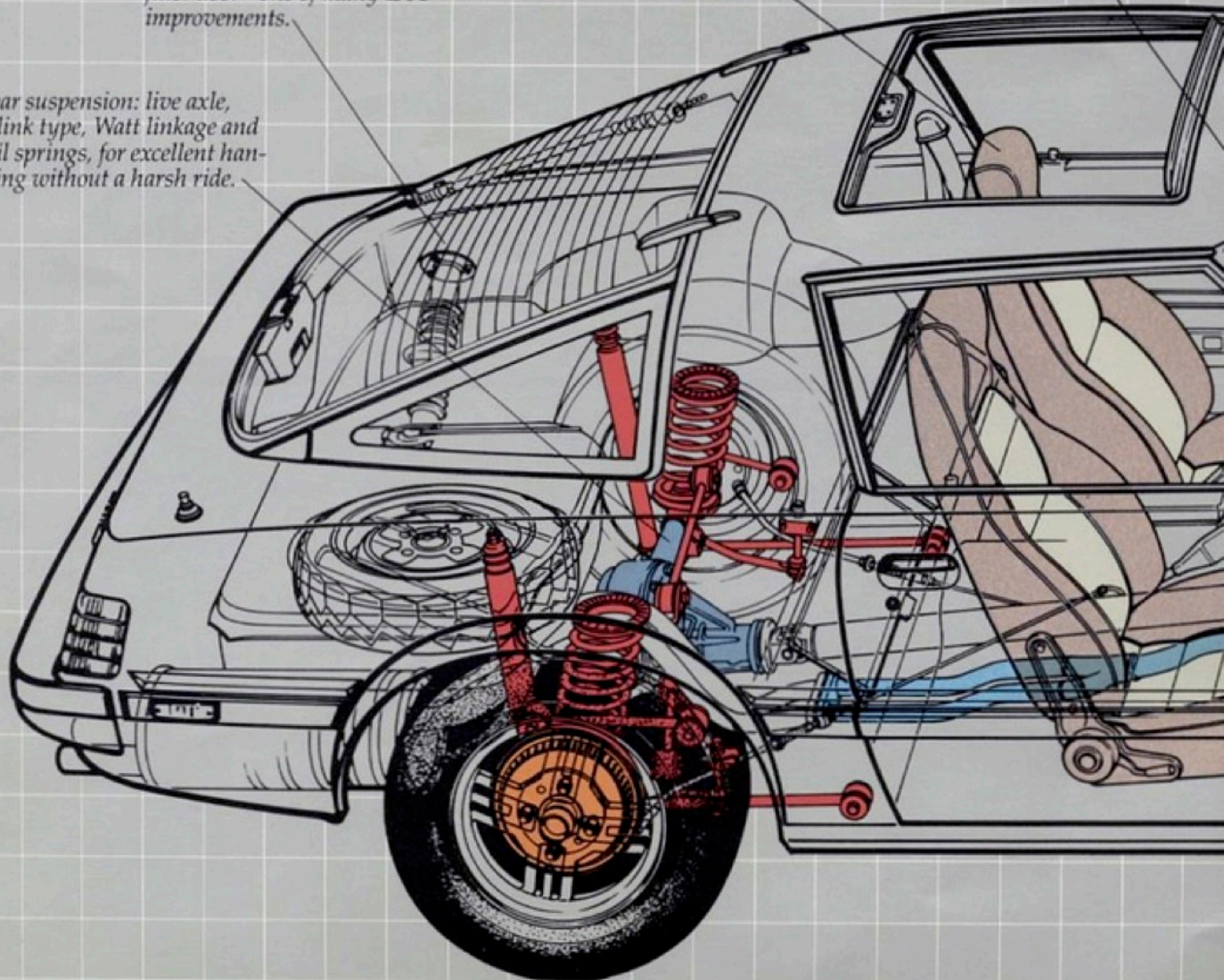

overall. It was merely the best overall finish ever achieved by cars of this class. Auspicious start.

In the 1980 International Motor Sport Association (IMSA) season of 14 races on legendary courses around the country, RX-7 walked away with the GTU class championship and its

drivers swept the top three spots for overall points. **A refined RX-7 emerges.** *Motor Trend* noted, "... 1981 brings even more refinement. Some subtle suspension alterations have improved transient response, directional stability and quality of ride;"—and named RX-7 its sports car "MT Best Buy"

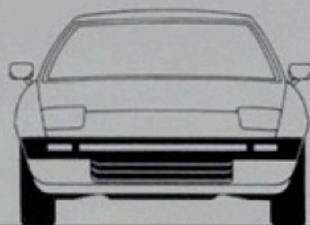

30
EST. hwy mpg

21
EST. mpg

See page 14 for details.

in its April, 1981 *Import Car Buying Guide*.

"Distinctive improvements for a super sports car," agreed *Road & Track*.

"... one of the outstanding sports cars available in the world today, especially

considering price," opined *Car and Driver*.

Mazda engineers had honed the RX-7 sheet metal to new aerodynamic efficiency and appearance. At the same time, they endowed it with significantly improved fuel economy. And they had created a new ultimate RX-7—GSL with special touches all its own.

New touches for '82.

They are few, and studied—RX-7 owners would have it no other way. But if you have a lust for the outstanding sports car of our time—at an incredibly reasonable price—they will suffice.



Sophisticated instrumentation. Electronic check panel. AM/FM stereo radio. All standard.

Variable-ratio, recirculating ball-and-nut steering. Precise. Smooth. Direct.

Twin-rotor RX-7 engine is remarkably powerful for its size—provides four-electrode spark plugs for improved combustion.

Standard urethane-wrapped front and rear bumpers contribute to reduced weight and a sleeker appearance.

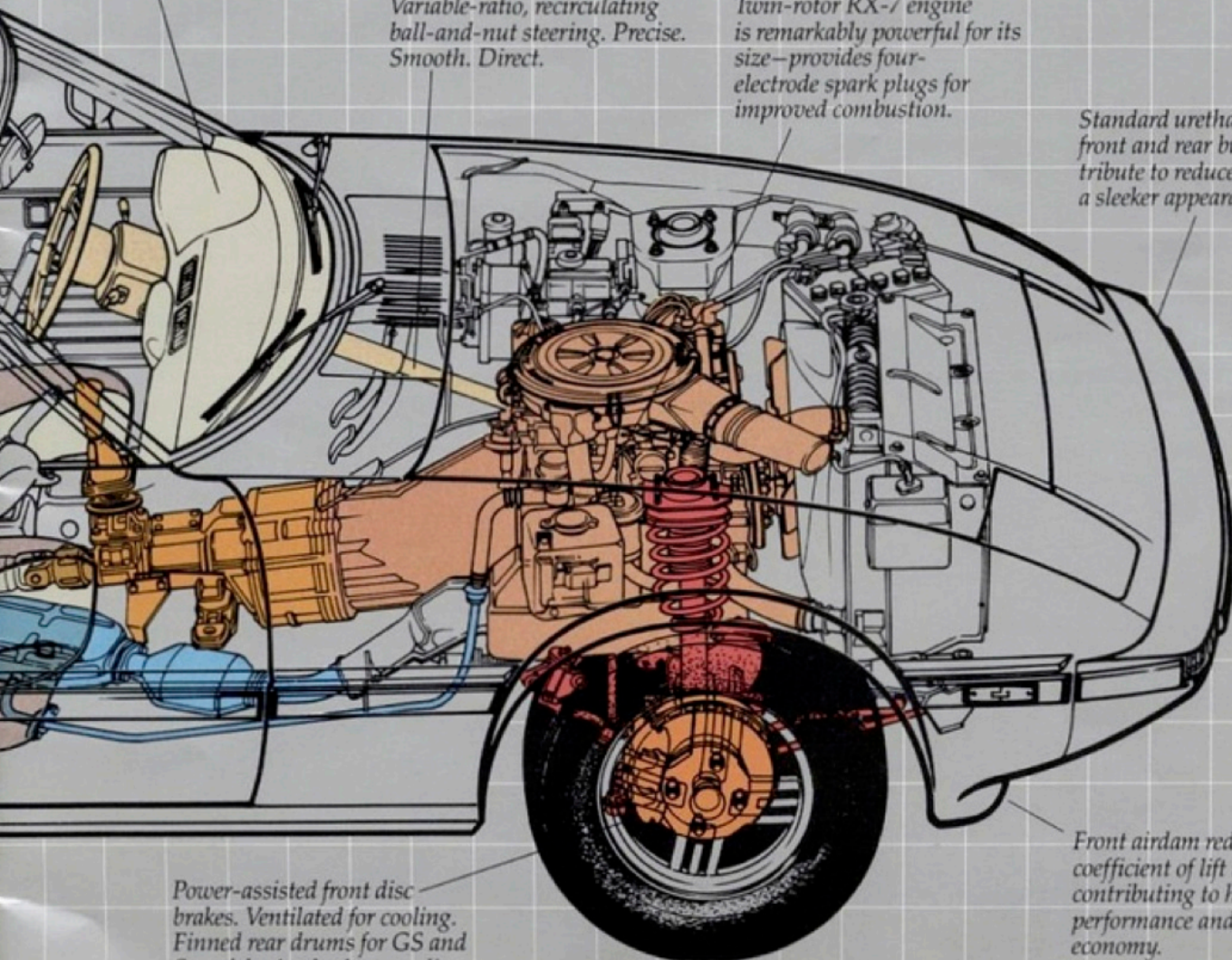

Power-assisted front disc brakes. Ventilated for cooling. Finned rear drums for GS and S models; 4-wheel power disc brakes for GSL.

Front airdam reduces coefficient of lift to 0.12, contributing to handling, performance and fuel economy.

GSL: The ultimate RX-7

"...Still the one to beat in today's sports car competition."

Road & Track

While many of *Road & Track's* comments could apply to all RX-7s, their test car was a 1981 GSL.

Though some purists still claim sports cars are supposed to be spartan, the response of press and buyers alike seems to indicate otherwise.

The GSL amenities. For the purist in you, note that GSL does have its own mechanical niceties: 4-wheel

power disc brakes, and a limited-slip differential. Some might consider the aluminum road wheels and raised letter tires in this area, but Mazda engineers insist their real purpose is primarily cosmetic. So be it. Either way, they complement the essence of the machine.

Two other GSL features discernable from the outside are shown at far right:

a steel sunroof that raises or lifts out, and a rear window washer/wiper are both standard. There are many more, of course, shown and listed on the next pages.

RX-7's inherent advantage. Its twin-rotor engine is one of the highest

performance-to-weight normally-aspirated engines ever developed. It has few moving parts, a smoother combustion process, and phenomenal power efficiency.

Another advantage: because it is so compact,

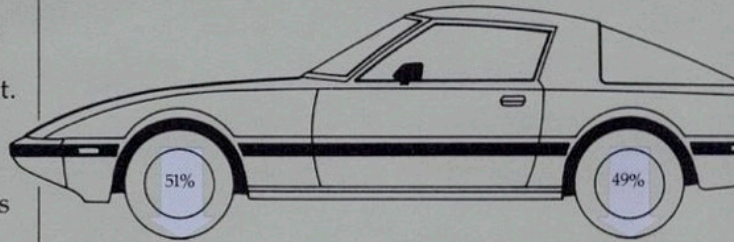

A balance you can feel on the road.

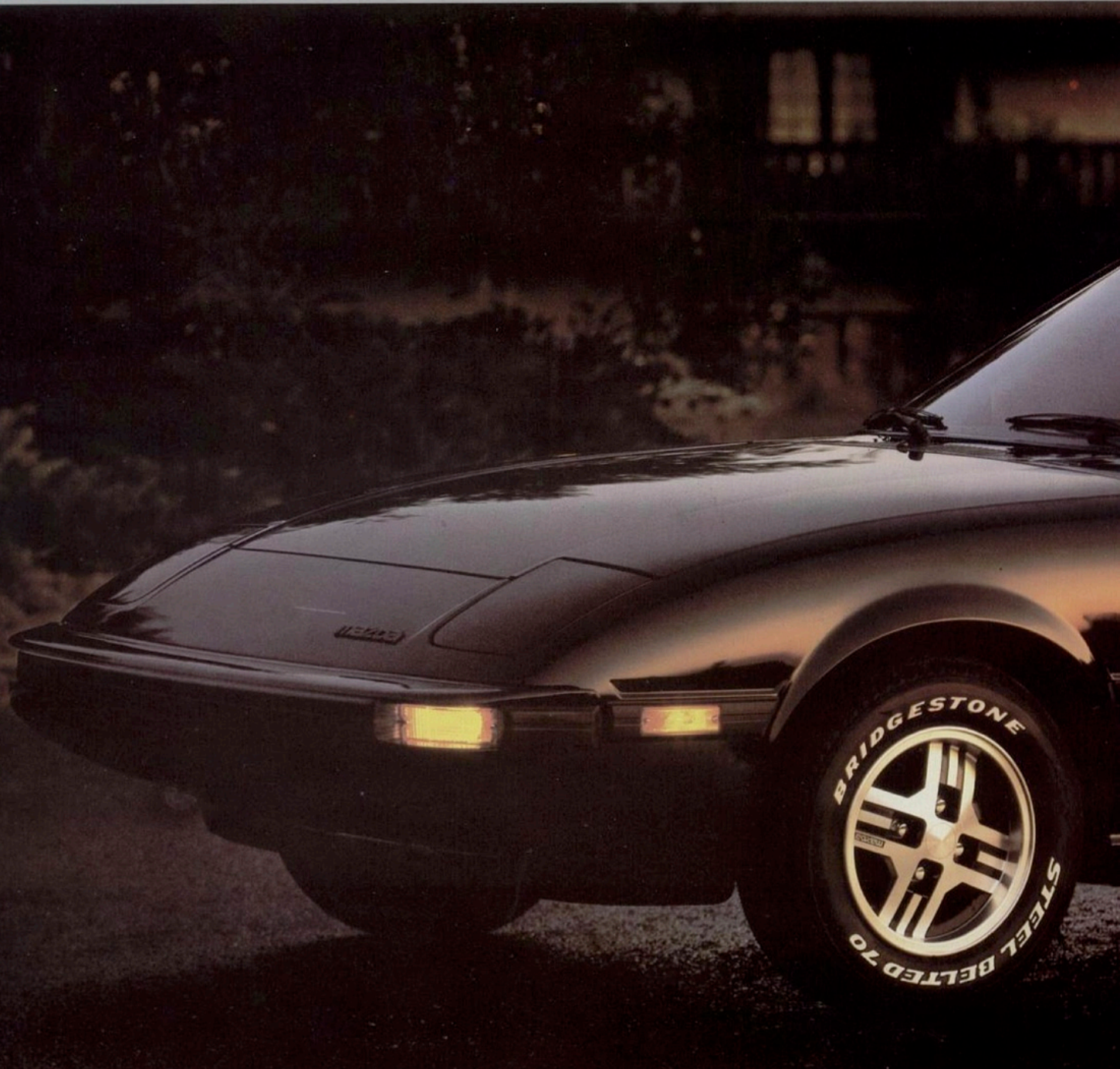

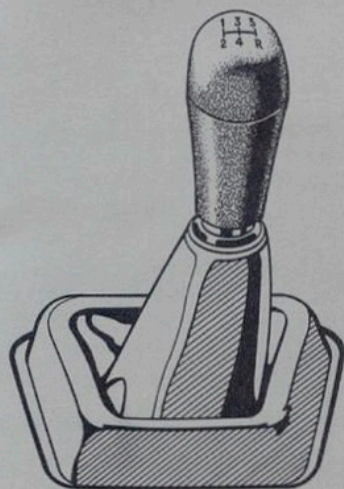

5-speed overdrive transmission is teamed with the "rotary rocket."

is placed *behind* the front axle, in what is actually a front mid-engine position. As a result, RX-7 weight is poised in a 51/49 percent balance between front and rear wheels. Moreover, its center of gravity is a scant 18 inches above ground level.

Now, implement these advantages with such components as the sophisticated suspension and quick, precise steering, and what you have is a chassis that is beautifully equal to the awesome acceleration of the engine and the quick-shifting 5-speed overdrive transmission.

The RX-7 experience. It is unique among sports cars—for this is the only one in the world with a high-performance rotary engine. Its distinctive sound and spectacular acceleration (0 to 60 in 8.6 seconds) can trigger a new world of sensations and reactions within even the most sophisticated enthusiast.

Couple this with outstanding feel of the road and responsiveness to the wheel, and you have a machine that raises a mundane commute or a backroads joyride to new levels of enjoyment.

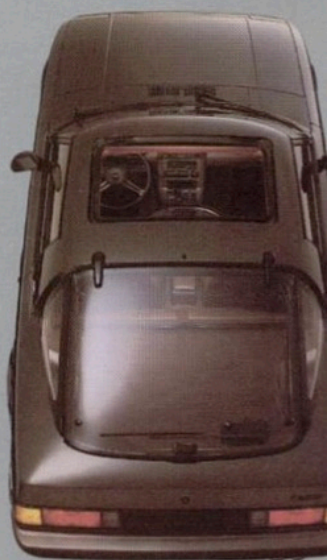

Inside the GSL: Here's where the highest level of performance is raised to the highest level of luxury.

First, the luxurious leather seats and door inserts shown below (1) are optional—and practically irresistible. The automatic transmission shown at right, and air conditioning are also options—all the other features mentioned on these two pages are standard.

The GSL ambiance. Even if you've driven an RX-7 before, the GSL will be a revelation. Mazda's design-

ers and engineers have prepared an environment which will bring you into perfect harmony with the sophisticated machine at your command, and they have graced it with a dazzling array of creature comforts.

The seats, whether in leather or with fabric panels as shown at far upper right, are exclusive to the GSL. They're especially shaped and contoured for still

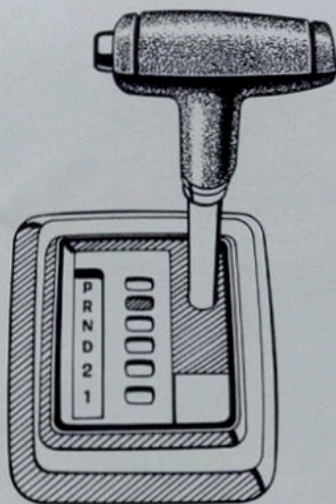

Automatic transmission—optional for GSL and GS.

greater lateral support, as the head restraints are adjustable.

The GSL sound system. The GSL also provides a premium-quality sound system (3) consisting of an AM/FM stereo radio, a Dolby™ system cassette deck, dual front speakers, two-way coaxial rear speakers plus power amplifier and fader control.

Picture 4 reveals still more GSL touches: power window controls, the rear window washer/wiper, the cruise control activa-

Once activated, Mazda's cruise control (4) offers a convenient "co-



feature. The end button sets the speed; but once set, you can twist the knob down and you'll "coast" down in speed when approaching traffic or at a crossroad; twist it back up, and you resume the pre-set speed. Touching the brake pedal cancels the setting, of course.

There are a dozen GSL touches in all, but remember that these are in addition to all the deluxe features provided in the RX-7 GS—features ranging from electric remote-control sideview mirrors to electric hatch and fuel-filler door releases to a rest for your

clutch foot. The complete listing is on page 15.

The GSL command post.

The objective was to make the feel of driving an RX-7 (2) as instinctive and natural as breathing—an extension of one's senses into the functions of the automobile.

You'll find the dials and gauges are precisely placed for quick communication. Controls have been meticulously refined and located for instant accessibility and operation.

With typical Mazda thoroughness, the ergonomics of RX-7 instrumentation have been carefully refined to a remarkable

level. Even to the point of moving the gearshift four inches closer to hand than it was originally.

The shifter handle was also redesigned to help make RX-7—as *Road & Track* observed in 1981—"... immediately comfortable to drive... a tastefully trimmed and outfitted sports car with many luxury touches."

Now that you've seen what makes GSL the ultimate RX-7, you just might want to find out what makes it the ultimate sports car. So take a test-drive and see.

The standard GSL seat.

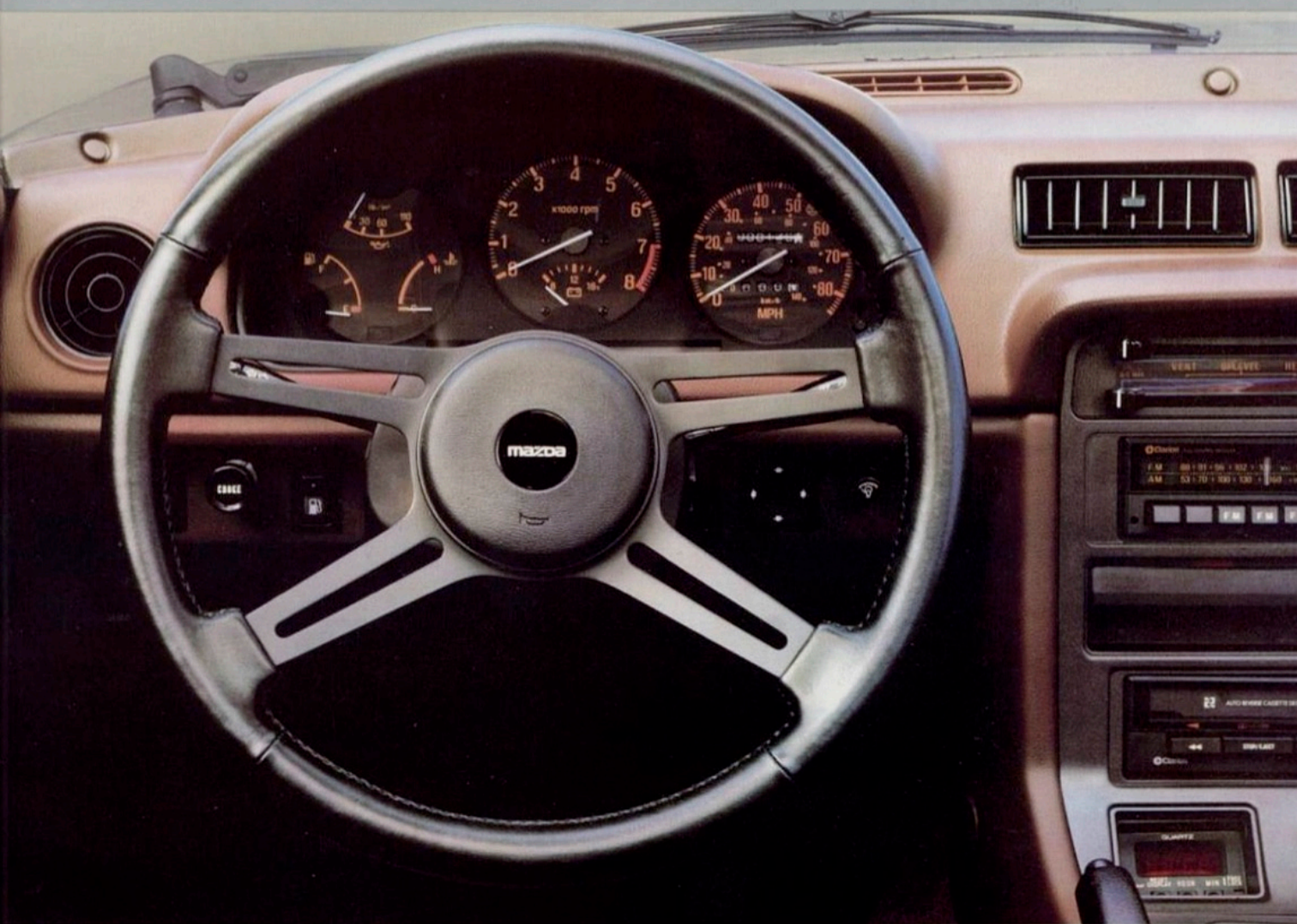

If today's RX-7 GS seems sleeker than the original, it's no illusion. Mazda designers shrank its coefficient of drag to an incredible 0.34.

In its sleeker, more potent look lies a classic example of Mazda's dedication to the principle that form follows function. Through months of racing and wind-tunnel testing, Mazda designers subtly refined the aerodynamics of the original silhouette to make it not only more slippery, but purer and bolder aesthetically. Front, side and rear became fully integrated.

Many subtle refinements in 1981. Veteran RX-7 watchers should have little trouble spotting them. First the front airdam was recontoured to a more efficient shape and sculpture, and formed of a more weight-efficient synthetic. The bumpers above it were urethane-wrapped, reduced in weight, and given a cleaner look.

Body side mouldings

were made wider and lower, and lined up with the bumper facing, to create a simpler, unifying line that complements the clean simplicity of the body planes.

A major sculpturing refinement made the rear detailing smoother and

cleaner. The deck below hatch now sweeps down a single unbroken plane a wide slash of darkened lens which masks the taillights. So the RX-7 looks clean and distinctive going away as it does coming at you.

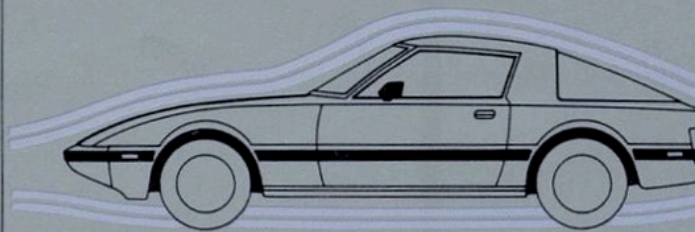

RX-7 now has a more efficient airfoil than originally.

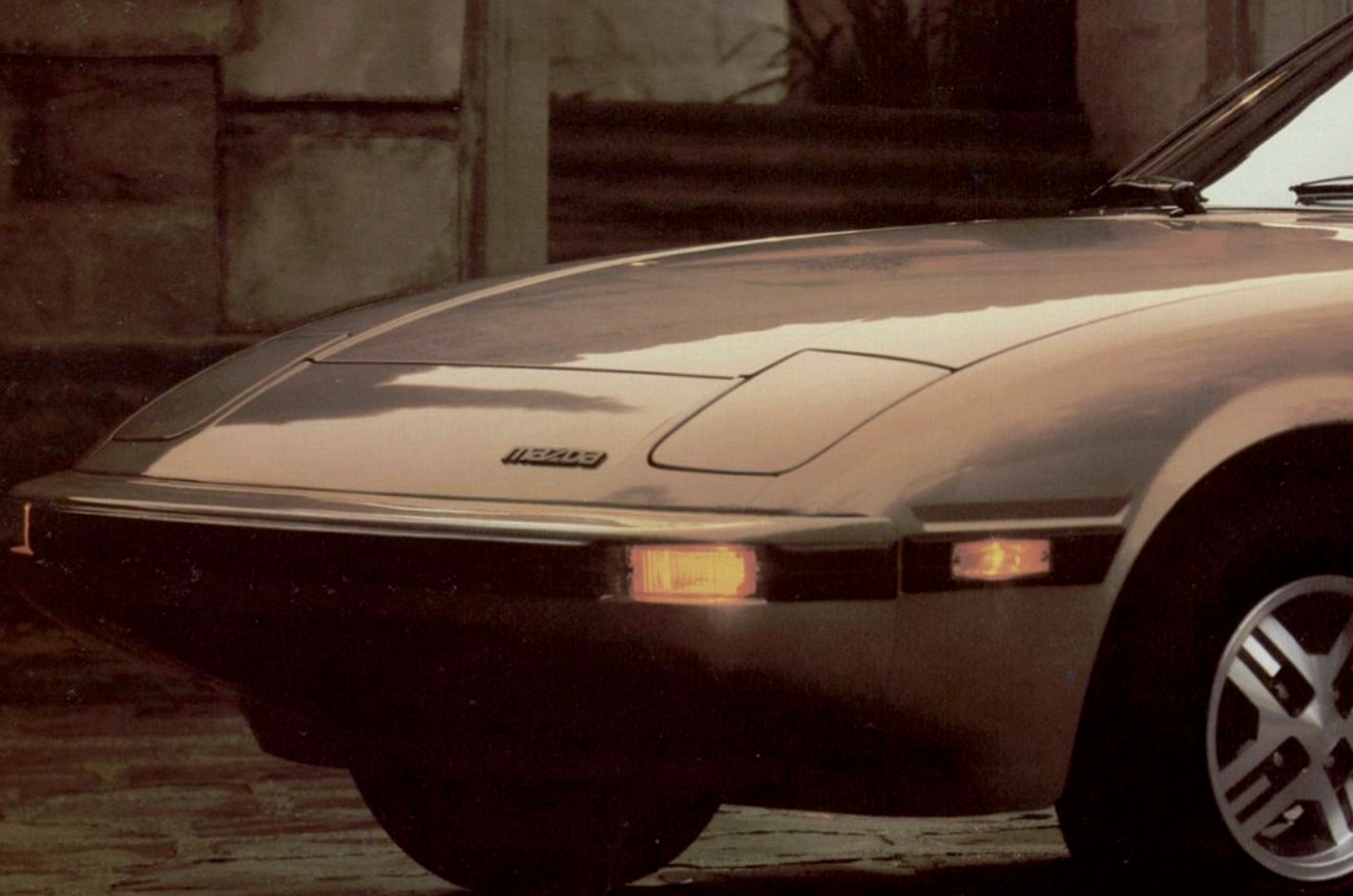



The sleek RX-7 look, going away.

Two key GS options:

One you've already noticed: the high-tech look aluminum road wheels which are standard on the GSL are also available for the GS. And they fit the extra-wide 185/70HR-13 steel-belted

radial tires which are already standard on the GS.

The second option: a removable steel sunroof. Combine the two, and you have an interesting possibility: Your GS can have much of the look of a GSL—

for the price of just these two options. GS also offers air conditioning and an automatic transmission as other options.

Value: more than just a buzz word. In a GS, it's built-in standard equipment; in fact, value is a key part of Mazda's concept of what sports car enjoyment is all about. So consider what you get in a GS—and how much these features would add to the price of a lesser car: AM/FM stereo radio with four speakers, power amplifier and fader control • Dual electric remote-control sideview mirrors • 5-speed overdrive

manual transmission
• Two-speed wipers with intermittent-action feature
• Tinted glass • Halogen headlamps • 185/70HR-13 blackwall steel-belted radial tires • Digital quartz-movement clock.

There are many more listed on page 15, but these alone suggest the incredible value in a RX-7 GS. And when you consider how many are ordinarily accessories which run up the price of would-be "sporty" cars, you can see why GS is indeed a great value over and above its unique capabilities as a high-performance road machine.



The true excitement of an RX-7 GS is reserved for the private pleasure of those privileged to bring its rotary power to life.

This is the car that set the state-of-the-art and the standard of value in sports cars when RX-7 was unveiled. It has been refined, improved—but never compromised.

And this is where you begin to appreciate its incredible value when compared to other authentic sports cars like Porsche 924, as well as those judged "sporty" or "GT" by hard-

core buffs.

Inside (1) the RX-7 GS is every bit the sports car it appears to be outside. Note the beautifully tailored high backed bucket seats, swathed in rich velour, the business-like gear shifter, the map pockets in the doors, the full console with its storage bin—there's nothing stripped down or ersatz here. It's downright luxurious.

Then look at the dash.

It's an enthusiast's dream (2). An instrument panel so completely equipped (all standard) is a rarity today. Behind the four-spoke wheel, you see a tachometer. Temperature gauge. Oil pressure gauge. A voltmeter. Resettable trip odometer. Plus an elec-

tronic check panel that warns you if a brake light burns out. And now, even a warning chime to warn you if the oil or coolant levels fall to critical levels.

Extra GS touches. Like the electric remote-control sideview mirrors, the clutch foot rest. An electric remote hatch release (3). A swit-

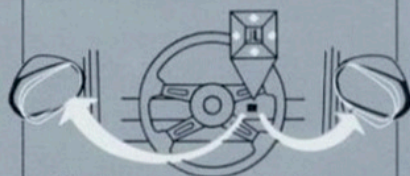

Electric remote control mirrors are standard on RX-7 GS.

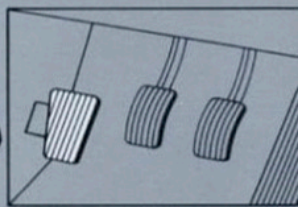

... So is a rest for your clutch foot.

10



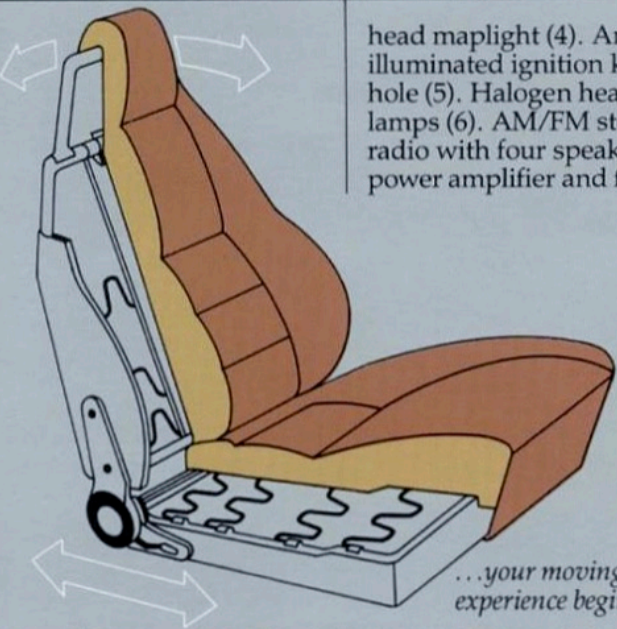

head maplight (4). An illuminated ignition keyhole (5). Halogen headlamps (6). AM/FM stereo radio with four speakers, power amplifier and fader

...your moving experience begins here.

control (7). Cargo tie-down strap (8). Digital quartz-movement clock (9). And more. (See page 15).

3-support-zone seat. The RX-7 driver's bucket seat has been so carefully designed that its orthopedically shaped contours are sculpted in urethane padding with three degrees of firmness. The softest provides firm but yielding comfort in the seat cushion. A firmer seatback cushion offers additional lumbar support. And the firmest is used in the seatback side bolsters, to give you stout lateral support as you thread a tight turn. It's a



bucket seat totally designed to help keep you in comfortable command, however twisting your course.

Above, you see the sunroof you can opt for. It's an extra touch that can complete RX-7 as your definitive sports car. The more sophisticated your driving abilities, the more you'll find to marvel at.

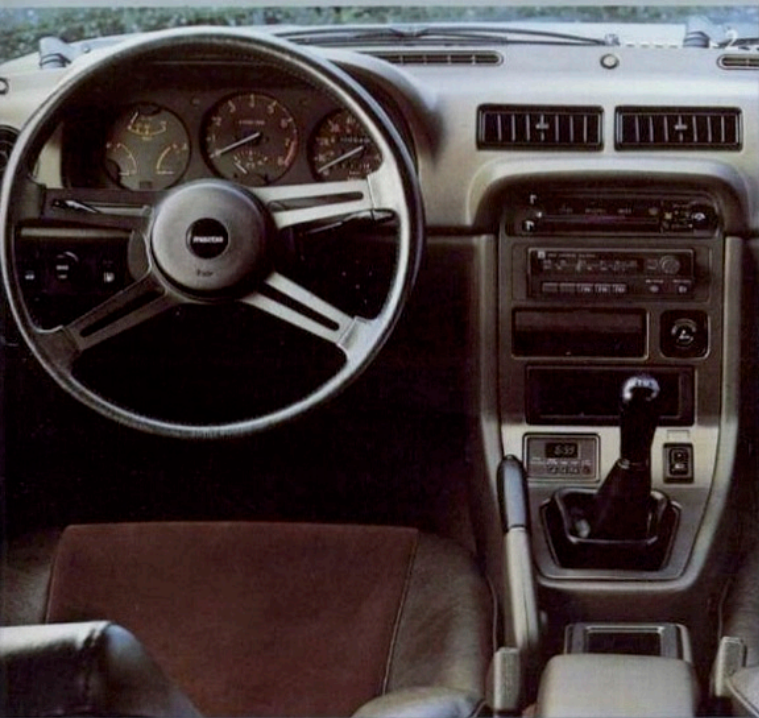

RX-7 S: Perhaps the most performance per dollar you can buy today—and the only high-performance car at anywhere near its price.

The wonder of Mazda's lowest-priced RX-7 is not how much it differs from the exotic GSL and richly-appointed GS, but how much it is the same. Which simply means that here you have an authentic high-performance sports car of superior design and appearance, for approximately the price of a well-appointed conventional automobile. And that's where any com-

parison ends.

Stowaway lockers.

Like other RX-7s, the S has two covered compartments behind the seats. Each is 18½ inches wide, 7½ inches high, 9 inches deep at the top, 12 inches deep at the bottom. They're roomy enough for cameras, tote bags,

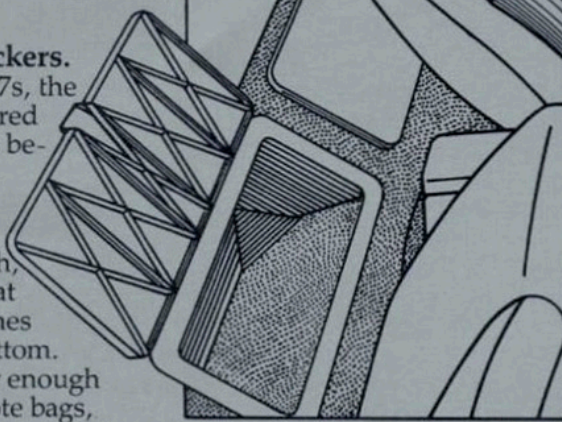

whatever—and accessible only when the seatbacks are folded down.

Full instrumentation

Every gauge and dial you saw on the GS instrument panel is left intact (1)—no blank spots where the gauge or tachometer would have been. And the same 5-speed overdrive (2) is standard equipment. You still have dual sideview mirrors (3)—but you adjust them manually. And the same high-quality velour is used for the fabric upholstery (4).

So what you have where it shows are all the essentials of what has m-



RX-7 a legend in its own time: the looks, the feel, the action of a rotary-powered sports machine—minus a few of the niceties to hone the price down within reach of more enthusiasts. Nevertheless, the features which remain as standard equipment are most impressive:

All of this: Twin-rotor engine • 5-speed overdrive transmission • Front and rear stabilizer bars • Tachometer • Oil pressure, temperature, and voltmeter gauges • Resettable trip odometer • Electronic check panel • Remote control fuel filler door release • Analogue quartz



clock • Electric rear window defroster • Tinted glass • Day/night rearview mirror • Vanity mirror • Door map pockets • Nylon cut-pile carpeting • Reclining

bucket seats • Side window demisters • AM/FM stereo radio with two speakers • Power antenna • 2-speed wipers with intermittent action • Dual horn

• And more.
The more you look . . . the more you'll like the way Mazda builds the RX-7 S. If you're an enthusiast, it is indeed a dream come true.



A closer look at the anatomy of Mazda RX-7 - The high-performance "Rotary Rocket"

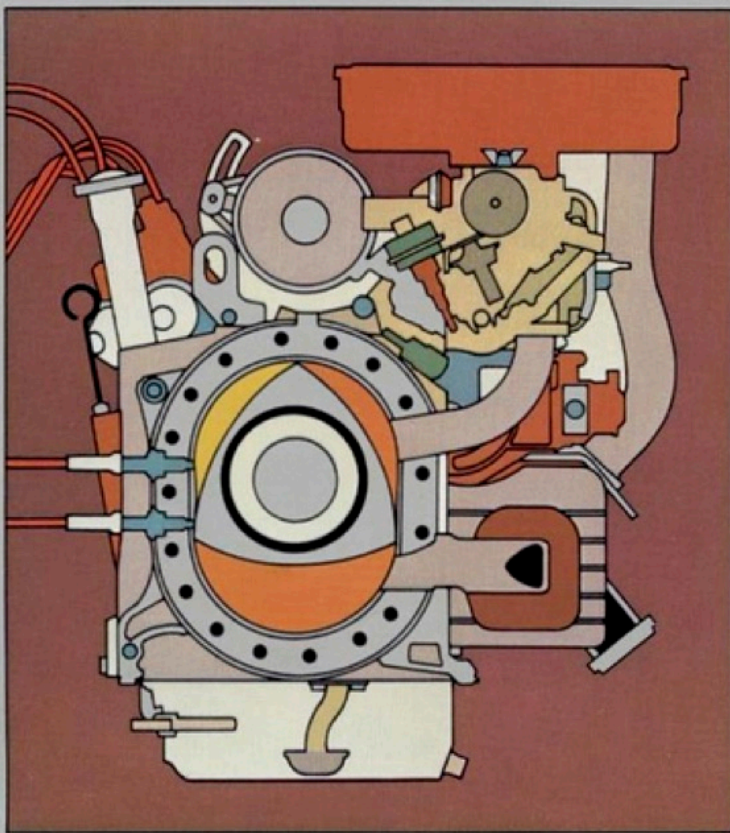

Engine. Rotary, twin rotors inline. Displacement: cu. in. (cc) 35 x 2 (573 x 2). 100 hp at 6000 rpm, 105 lbs.-ft. torque at 4000 rpm (SAE net). Compression ratio: 9.4:1. Downdraft, 2-stage, 4-barrel carburetion. Electric fuel pump. 4-electrode spark plugs. Water cooled. Catalytic converter

emissions system. The RX-7 engine is among the most powerful for its size in the world. It is quick, responsive and smooth. Electrical system: 12 volt. Battery, 12 volt, 45 ampere hours. (55 ampere hours with automatic transmission, except California.)

Steering. Variable-ratio, recirculating ball-and-nut. RX-7's steering is smooth, quick and light, yet affords excellent feel of the road. Steering ratio: 17-20:1, 3.7 turns lock-to-lock; turning diameter, 31.5 ft.

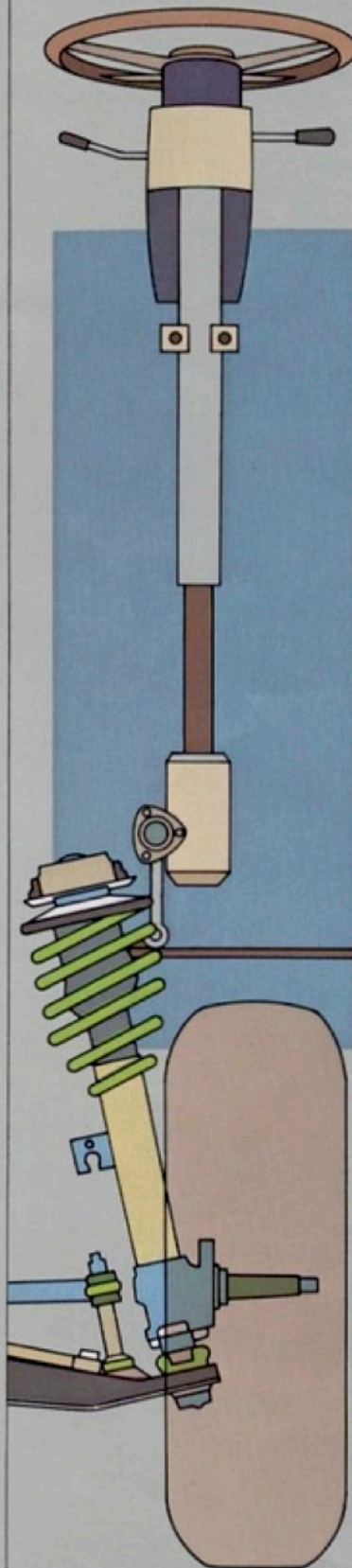

Brakes. Power-assisted front discs and self-adjusting rear drums for S and GS; power-assisted 4-wheel discs for GSL. vacuum servo power

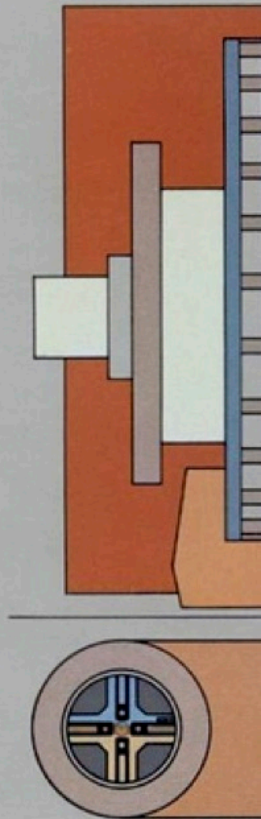

Wheels/tires. 5J style steel wheels with center lock standard on S and GS. 5 1/2J aluminum wheels standard on GSL, optional for GS and S (require 185/70HR13 tires). 165 blackwall steel radials standard for S. 185/70HR blackwall steel radials standard on GS, optional 185/70HR13 raised-leaf steel radials standard on GSL. Compact spare all models.

14

30 Est. hwy mpg **21** EST. MPG

EPA estimates for comparisons. Your mileage may

vary with trip length, speed and weather. Actual highway mileage will probably be less. In California: 30 est. hwy mpg, **20** EST. MPG.

Transmission. Fully synchronized, rear-wheel-drive 5-speed overdrive standard. Progressive, low-friction clutch. 3-speed automatic optional for GS and GSL.

Suspension. Front independent struts with tapered coil springs, stabilizer bar and tension rods. Rear: 4-link type, Watt linkage, coil springs and stabilizer bar. Live axle. Double-action shock absorbers, front and rear. Benefits: Controlled vertical motion on rough roads; restricted side motion of rear suspension; discourages lean in cornering. Wheelbase: 95.3 in. Track: 55.9 in. front, 55.1 in. rear.

Gear ratios 5-speed Auto

1st	3.674:1	2.458:1
2nd	2.217:1	1.458:1
3rd	1.432:1	1.000:1
4th	1.000:1	—
5th	0.825:1	—
Reverse	3.542:1	2.181:1
Final	3.909:1	3.909:1

All dimensions are in inches.

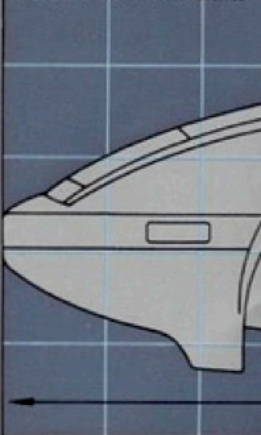

dual diagonal hydraulic circuits. Parking brake mechanically activated on rear wheels. Low center of gravity aids in achieving quick, flat stops.

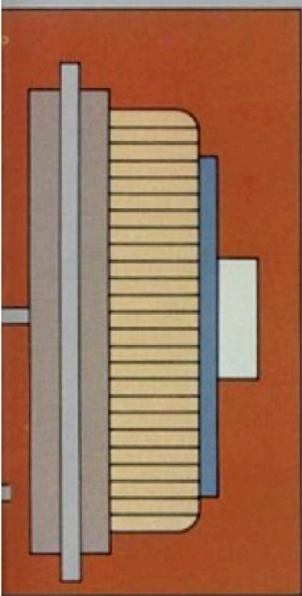

Dimensions. Overall length, 170.1 in. Width, 65.7 in. Height, 49.6 in. Ground clearance, 5.7 in. Fuel tank capacity, 16.6 gal. Curb weight: 2290 lbs. With automatic, add 35 lbs. Federal, 25 lbs. California; with air conditioning, add 55 lbs.

Interior dimensions. Headroom, 37.2 in.; with sunroof, 36.8 in. Legroom, 41.5 in. Shoulder room, 51.4 in.

Exterior colors. Formula White. Renaissance Red (Maroon) Metallic. Sunrise Red. Sunbeam Silver Metallic. Tornado Silver (Charcoal) Metallic. Brilliant Black. Stardust Blue Metallic. Maya Gold Metallic.

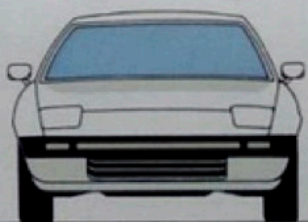

RX-7 Standard Equipment.

RX-7 S: Rotary engine • 5-speed overdrive transmission • Front and rear stabilizer bars • 165HR13 steel-belted radials • Styled steel wheels • Color-coordinated urethane covered bumpers • Blackout trim and mouldings • Chip-resistant rocker panel coating • AM/FM stereo radio with 2 speakers • Power antenna • Electric rear-window defroster • Front side-window demisters • 2-spoke soft-grip sport steering wheel • Tachometer • Resettable trip odometer • Voltmeter, temperature and oil-pressure gauges • Electronic check panel • Semi-automatic choke • Analogue quartz clock • Day/night rearview mirror • Dual sideview mirrors • Tinted glass • Dual padded sunvisors • Vanity mirror • Reclining bucket seats • All vinyl or vinyl-and-velour upholstery • Full center console • Door armrests • Door map pockets • Rear stowaway lockers • Remote-control electric fuel-filler door release • Two-speed wipers with intermittent-action feature • Full cut-pile carpeting • Power-assisted

brakes • Hidden headlamps, with headlamps-up-when-off control • Dual horn • Compact spare tire • Coat hook.

RX-7 GS: In addition to or replacing equipment on S model: 185/70HR13 black-wall steel-belted radials • Halogen headlamps • Tinted windshield with sunshade • AM/FM stereo radio with 4 speakers, power amplifier and fader control • Digital quartz clock • 4-spoke soft-grip sport steering wheel • Dual electric remote-control sideview mirrors • Cargo room light • Electric remote-control hatch release • Swivel-head map light • Driver's clutch footrest • Glove compartment light • Illuminated ignition-key cylinder • Headlamps-on reminder chime • Storage console with armrest • Cargo hold-down strap.

RX-7 GSL: In addition to or replacing equipment on GS model: Power-assisted 4-wheel disc brakes • Limited slip differential • Aluminum road wheels • 185/70HR13 raised-letter steel radials • Removable steel sunroof • AM/FM stereo with dual front speakers, two-way coaxial rear speakers, power amplifier and fader control. • Dolby™ System cassette deck • Rear-window wiper/washer • Special design reclining bucket seats with tweed fabric upholstery and adjustable headrests

• Matching fabric door trim
• Cruise control • Power windows.

Limited Engine Warranty. Mazda warrants that the basic engine block and its internal parts will be free of defects with normal use and prescribed maintenance for 3 years or 50,000 miles, whichever comes first, or Mazda will fix it free. This transferable, limited warranty is free on all new rotary-engine Mazda RX-7s sold and serviced in the United States and Canada. Mazda's Rotary engine is licensed by NSU-WANKEL.

Comparisons and magazine evaluations of RX-7 and other vehicles in this catalog are based on earlier competitive specifications, features and tests. For 1982, they may be different or changed from time to time by individual manufacturers.

Availability of specific options varies by geographic location, and may be available only in combination with other options. Also, specific combinations of colors, interiors, equipment, features or options may vary from time to time and by geographic area. Mazda reserves the right to make changes without notice at any time in prices, models, specifications, equipment, features, colors or options. Some equipment in this brochure is optional at extra cost.

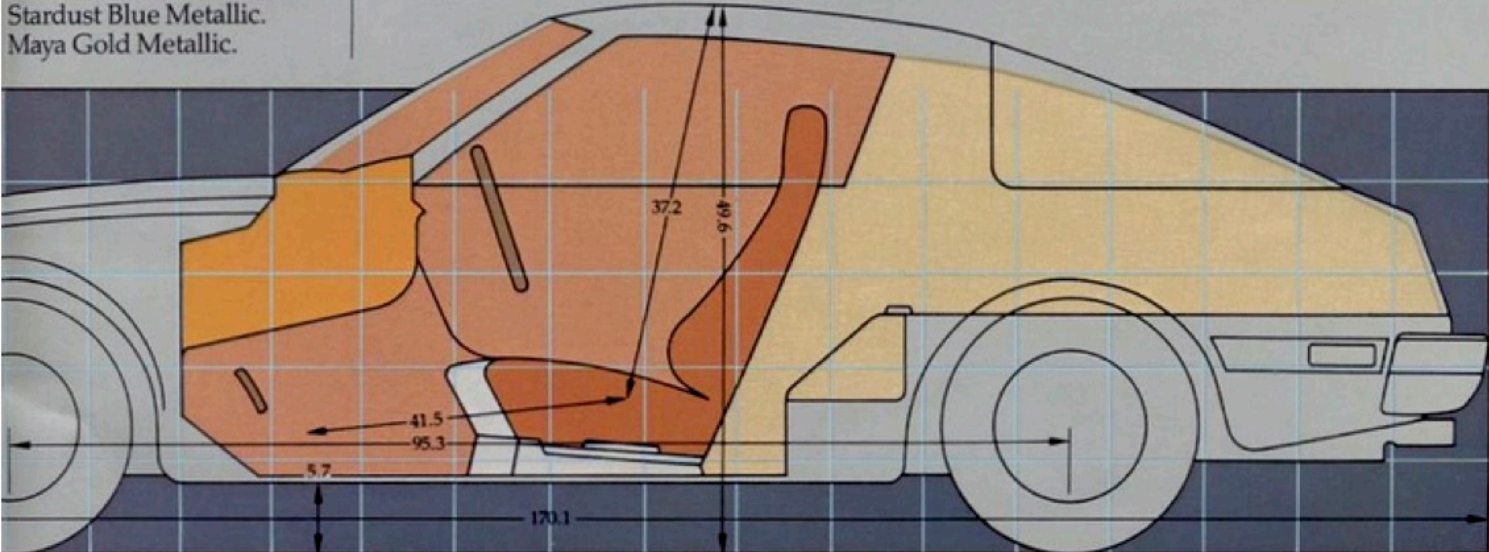

The more you look, the more you like.



mazda