

2024

Forester Wilderness



The 2024 Subaru Forester Wilderness. Adventure on a deeper level.



Introducing your escape from the indoors.

The 2024 Forester Wilderness.

The Forester Wilderness is for the off-road explorers, the fresh air enthusiasts—those who need to get outside. With 9.2 inches of ground clearance, dual-function X-MODE® and revised gearing that's engineered for climbing, this Forester is ready for your all-terrain adventures. Unique, rugged styling details, like a glare-reducing hood decal, set the Wilderness apart from the pack, and since it's a Subaru, safety is a top priority—EyeSight® Driver Assist Technology¹ comes standard.

[View Inventory](#)

[Locate a Retailer](#)



Forester Wilderness in Geysers Blue.

Bumps in the road encouraged.

With more ground clearance than any other Forester, the Wilderness is designed to handle rough terrain with ease. Plus, a standard front skid plate protects your engine from dirt, rocks and debris. The front and rear bumpers of the Wilderness are designed with improved approach and departure angles, so you'll be able to clear obstacles and take on steep climbs.

9.2"

Ground clearance



Front skid plate



Improved approach and departure angles



17-inch matte-black-finish alloy wheels with Yokohama® Geolandar® All-Terrain tires



Forester Wilderness in Geyser Blue with accessory equipment.

Anywhere.
Any weather.

All-Terrain Yokohama® Geolandar® tires

For off-road grip and on-road comfort, Forester Wilderness features Yokohama® Geolandar® tires mounted on 17-inch matte-black-finish alloy wheels. A unique tread design ensures a confident ride, whether the path ahead is slippery, rocky, snowy or muddy. And you can have even greater peace of mind knowing you have a full-size spare.

Go beyond the road less traveled.

Subaru Symmetrical All-Wheel Drive

In the Forester Wilderness, you can count on standard Subaru Symmetrical All-Wheel Drive to deliver stability and traction no matter the conditions. This active torque-split AWD system is able to optimize power distribution between the wheels to maximize grip on rugged trails or slippery roads.

Dual-Function X-MODE

When tackling tougher roads, standard dual-function X-MODE allows you to adapt with the right amount of traction for different situations. The first setting, Snow/Dirt mode, minimizes wheelspin and maximizes grip. This setting also activates Hill Descent Control to help keep you at a slow, even pace through steep off-road declines. The second setting, Deep Snow/Mud mode, allows for more wheel slip when needed to power through adverse conditions.

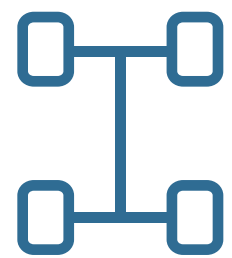

Subaru Symmetrical
All-Wheel Drive

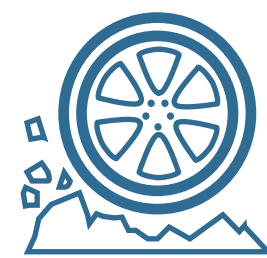

Dual-Function
X-MODE



Forester Wilderness in Geyser Blue with accessory equipment.

An SUV with a can-do attitude.

At the heart of the Forester Wilderness is the reliable, direct injection SUBARU BOXER® engine with 182 horsepower. Retuned drivetrain gearing with revised ratios provides improved low-speed climbing—up to a 40 percent grade. With the ability to tow up to 3,000 pounds,² the Forester Wilderness is ready for extra gear and even a small camper, boat or trailer.²



Up to 3,000 lbs.
towing capacity²



Revised drivetrain
gearing



SUBARU BOXER
engine



Bold looks for bold adventures.

For rugged, trail-ready style and extra off-road protection, the Forester Wilderness is outfitted with functional design details. Protective exterior cladding covers the wheel wells and lower impact zones, and the anti-glare hood decal provides enhanced visibility on bright days. The black-finish trim with Anodized Copper-finish accents, exclusive Wilderness badging and Wilderness-only Geyser Blue exterior paint will turn heads on every journey.



Hexagonal LED fog lights

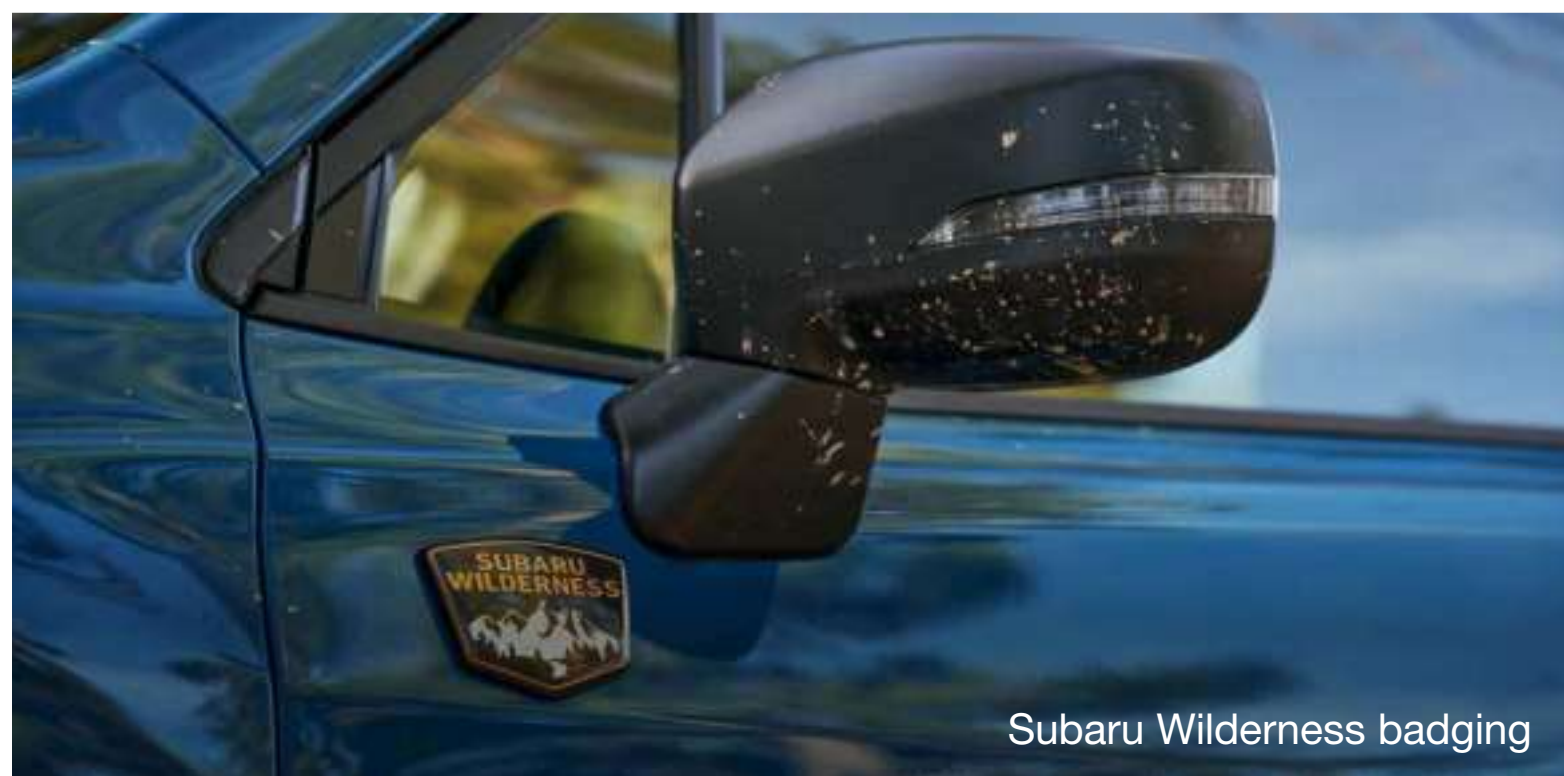

Subaru Wilderness badging



Matte-black, anti-glare hood decal

Engineered for the gearheads.

Bring all the equipment and gadgets—because the Forester Wilderness has wider, reinforced roof rails with Anodized Copper-finish accents designed to carry more weight. The dynamic load capacity is 220 pounds, so you can fill your Thule® cargo carrier to the max or transport larger gear like bikes, skis, snowboards, kayaks, paddleboards and more. When you're parked, the static load capacity is 800 pounds, meaning a rooftop tent³ might be your next outdoor home base.

[Shop Accessories](#)

In your element, on the go.

With an extra-wide rear gate opening, an LED cargo gate light and an available Power Rear Gate, the Forester Wilderness makes loading and unloading hassle-free. Inside, you'll have 69.1 cubic feet of cargo space for all your gear and 60/40-split flat-folding rear seats that collapse with the press of a button. Plus, protective materials throughout the cabin stand up to even the dirtiest hiking boots and paws.



Forester Wilderness in Geyser Blue
with accessory equipment.



Forester Wilderness in Geyser Blue.



Forester Wilderness with Gray Textured StarTex® and optional equipment.

8.0"

Multimedia
touchscreen



180-degree
Front View Monitor

An interior that's as outdoorsy as you.

The Forester Wilderness is meant to coexist with the outdoors. That's why this Forester has a durable, easy-to-clean interior with water-repellent StarTex upholstery. When trails get tight or rocky, the standard 180-degree Front View Monitor can help you navigate the challenging terrain ahead. Plus, an 8-inch touchscreen displays the SUBARU STARLINK® Multimedia interface, so you can easily access your music and apps via Apple CarPlay® and Android Auto™ integration. You can also opt for an integrated navigation system.⁴



Water-repellent StarTex upholstery



Water-repellent
StarTex upholstery

Far-out adventures, right-at-home feeling.

The interior of the Forester Wilderness is designed to keep you comfortable, connected and prepared. With Keyless Access with Push-Button Start, you can simply step in and start your Forester. For the colder months, the standard all-weather package equips you with heated exterior mirrors and a windshield wiper de-icer. You'll also get heated seats, a 10-way power driver seat and a panoramic moonroof—perfect for letting in natural light and fresh air. The second row offers standard dual USB-A charge ports and air vents. Wherever you're sitting, you can enjoy 4G LTE Wi-Fi capability⁵ and the available Harman Kardon® premium audio system.



An extra set of eyes every time you drive.

The Forester Wilderness includes standard Subaru EyeSight Driver Assist Technology.¹ Equipped with a comprehensive suite of innovative safety features, EyeSight looks ahead, alerts you to potential dangers and can even intervene to help you avoid a collision. Each safety feature is calibrated for increased ground clearance and off-road upgrades.



Forester Wilderness in Geyser Blue.



Automatic Emergency Steering⁶

Can help you avoid a collision by providing automatic steering and pre-collision braking support if it determines there's enough space to intervene.



Pre-Collision Braking

Can help slow and bring your Forester Wilderness to a full stop if necessary.



Advanced Adaptive Cruise Control with Lane Centering

Automatically helps keep you centered in your lane, at a safe distance behind the car in front of you—even in traffic and around curves.



Pre-Collision Throttle Management

Can reduce engine power to help give you more time to react and to help minimize possible impact force in case of a collision.



Lane Departure and Sway Warning with Lane Departure Prevention

If you accidentally begin to drift to the edge of your lane, EyeSight can alert you with visible and audible warnings before you cross over the lane markers. And when activated, Lane Departure Prevention can even help steer you back into your lane.

Built to protect what's most important.

To keep you, your passengers and those around you protected, the Forester Wilderness is equipped with our latest safety innovations. Standard LED Steering Responsive Headlights help you see better around corners, and hexagonal LED fog lights cut through in low-visibility conditions.



Forester Wilderness in Geyser Blue.



Blind-Spot Detection

Using radar sensors, Blind-Spot Detection⁷ warns you with a visual indicator on your exterior mirror if the system detects a vehicle in your blind spot. Another feature of this system, Lane Change Assist, alerts you with a flashing indicator on your exterior mirror if it senses a vehicle approaching at a higher speed in a neighboring lane.



Rear Cross-Traffic Alert

Rear Cross-Traffic Alert⁷ uses radar sensors to help warn you of traffic approaching from the side as you are backing up, utilizing a flashing visual indicator on your exterior mirror and standard Rear-Vision Camera display as well as an audible warning.



Reverse Automatic Braking

Reverse Automatic Braking⁸ can detect objects directly behind your vehicle when backing up at a low speed and can help bring the Forester Wilderness to a stop if it detects an object within its range and the brakes have yet to be applied. There's also the Rear-Vision Camera to help you keep an eye out.



SUBARU STARLINK Safety and Security

The Forester Wilderness features STARLINK Safety and Security,⁹ which can alert a first responder in an emergency, help police locate your vehicle if it's stolen and more. And to get you started, new Forester drivers enjoy a free three-year STARLINK Safety Plus trial, which includes Advanced Automatic Collision Notification, Enhanced Roadside Assistance, SOS Emergency Assistance and more.



Subaru. Lowest Cost of Ownership for three years in a row, according to IntelliChoice. Lower than Honda or Toyota brands.¹⁰

96% of Subaru Forester vehicles sold in the last 10 years are still on the road today.¹¹

Welcome to the Wilderness family.

Bored of the beaten path? Rough terrain and remote destinations are what the Subaru Wilderness lineup does best. With upgrades to ground clearance, drivetrain and all-terrain capabilities, each Subaru Wilderness SUV is engineered to take on just about anything. Even the styling details of the Wilderness models function as extra protection through rugged terrain and weather conditions. So grab your crew and pack up your gear; you've got some adventuring to do.

[Wilderness Family of Vehicles](#)



Subaru is rated #1 in safety for four years running.¹²

2024 Forester Wilderness

- 17-inch matte-black-finish alloy wheels and Yokohama® Geolandar® All-Terrain tires
- 9.2 inches of ground clearance
- Dual-function X-MODE with Hill Descent Control
- Enhanced Lineartronic® CVT gearing and rear differential
- 3,000-lb. towing capacity²
- SI-DRIVE® with Sport Sharp (S#) mode
- Engine skid plate
- Hexagonal LED fog lights
- Forester Wilderness exterior underguards, fender flares and side cladding
- Forester Wilderness-design front grille
- Matte-black, anti-glare hood decal
- Subaru Wilderness badging on front doors and rear gate
- Body-color rear spoiler
- Wider roof rails with increased static load-carrying capacity and 6 Anodized Copper-finish tie-down points
- Full-size spare tire
- Forester Wilderness Gray StarTex water-repellent upholstery with Anodized Copper-finish accents and contrast stitching
- Forester Wilderness-design all-weather floor mats
- Forester Wilderness gauges with color LCD display
- SUBARU STARLINK 8.0-inch Multimedia Plus with Apple CarPlay® and Android Auto™ integration, SiriusXM¹³ including 4-month trial and 3-year SiriusXM Traffic¹⁴ and SiriusXM Travel Link® trial subscriptions,¹⁴ 6 speakers, dual USB-A input ports and Bluetooth® audio streaming
- Dual-zone automatic climate control system
- 180-degree Front View Monitor
- LED cargo and rear gate light
- Blind-Spot Detection with Lane Change Assist and Rear Cross-Traffic Alert⁷
- Reverse Automatic Braking⁸
- One-touch folding rear seatback
- Cargo-area tray

Optional Package

Option Package (OP 22): • SUBARU STARLINK 8.0-inch Multimedia Navigation System • Harman Kardon® premium audio system • Power Rear Gate

Paint & Upholstery



Magnetite Gray Metallic



Ice Silver Metallic



Autumn Green Metallic



Geyser Blue



Crystal White Pearl



Crystal Black Silica

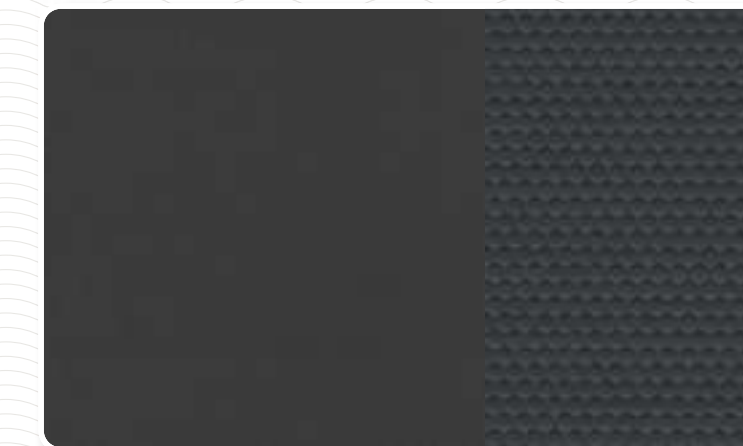

Gray Textured StarTex (GTT)

2024 Forester Wilderness

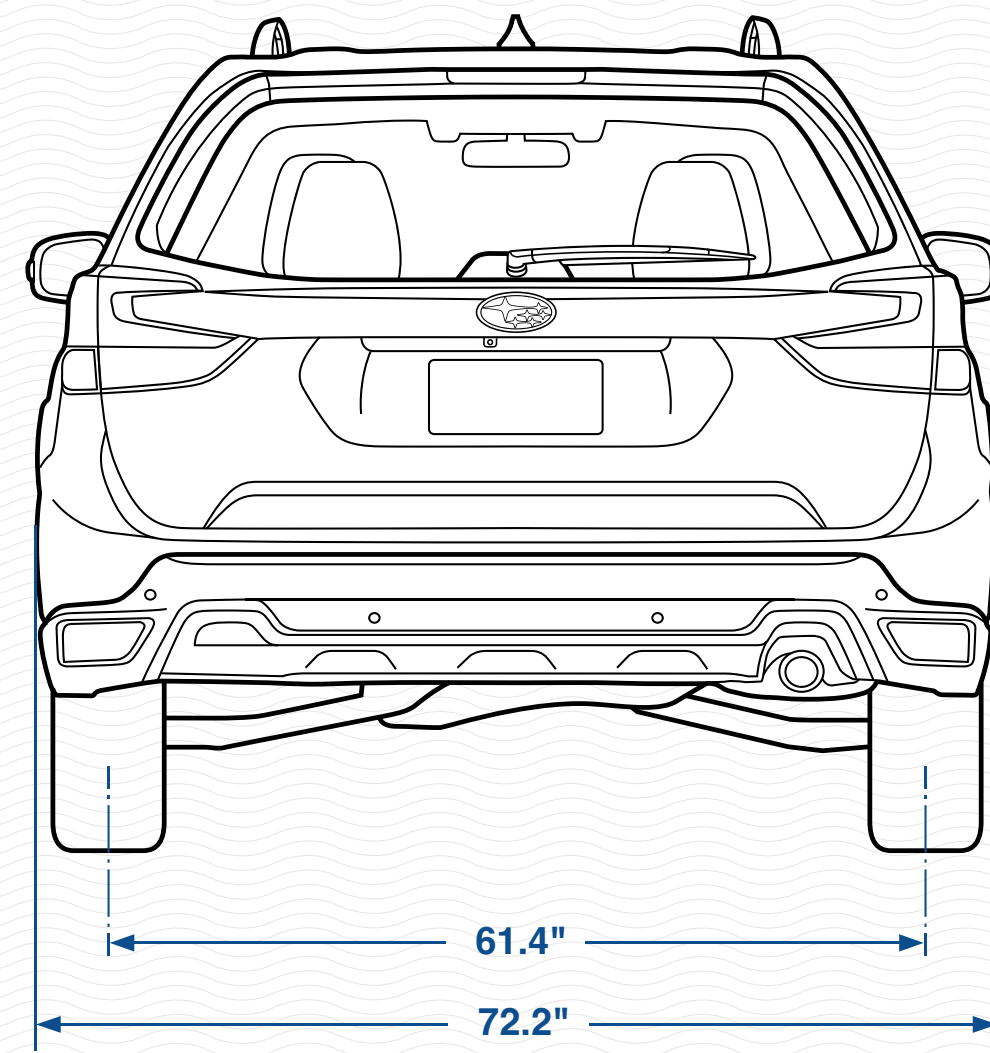
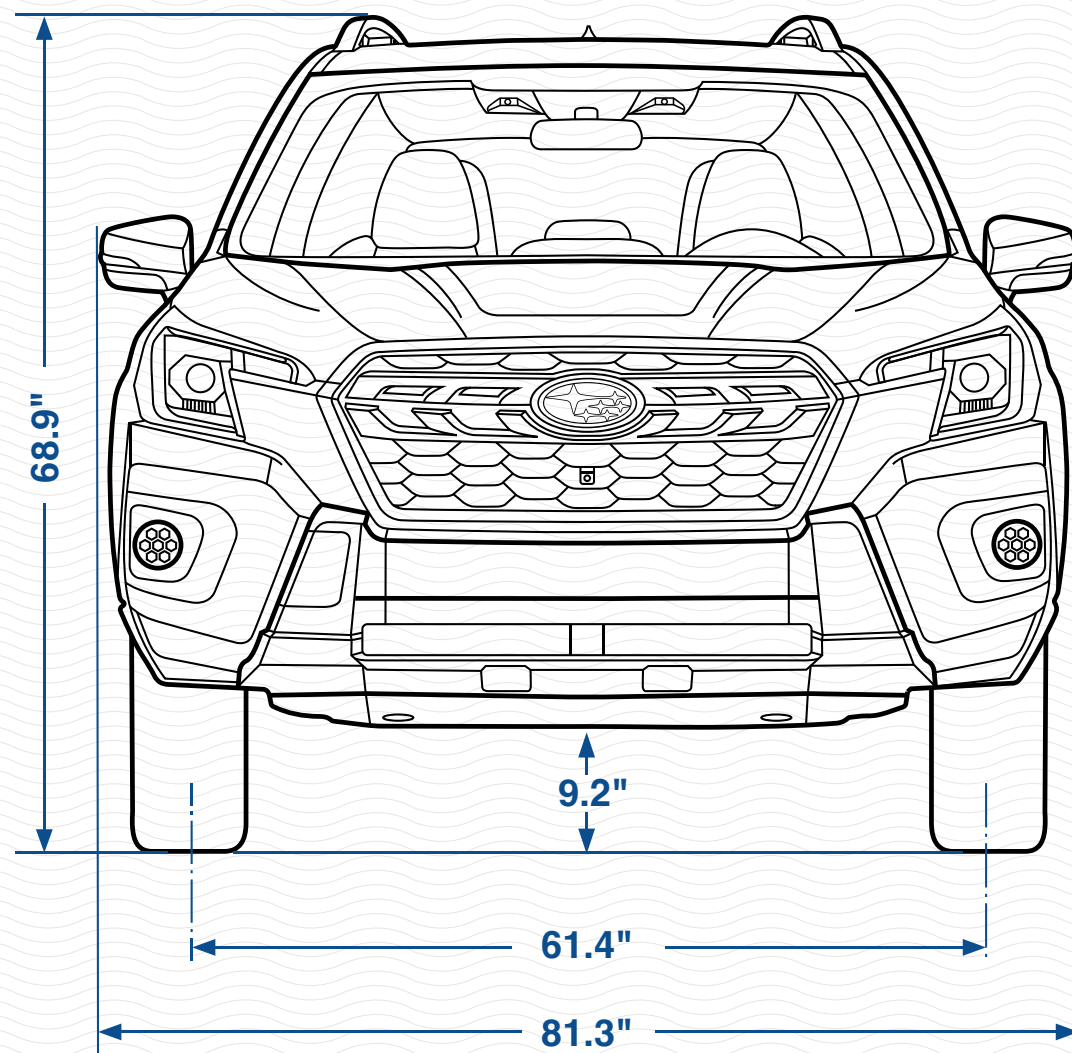
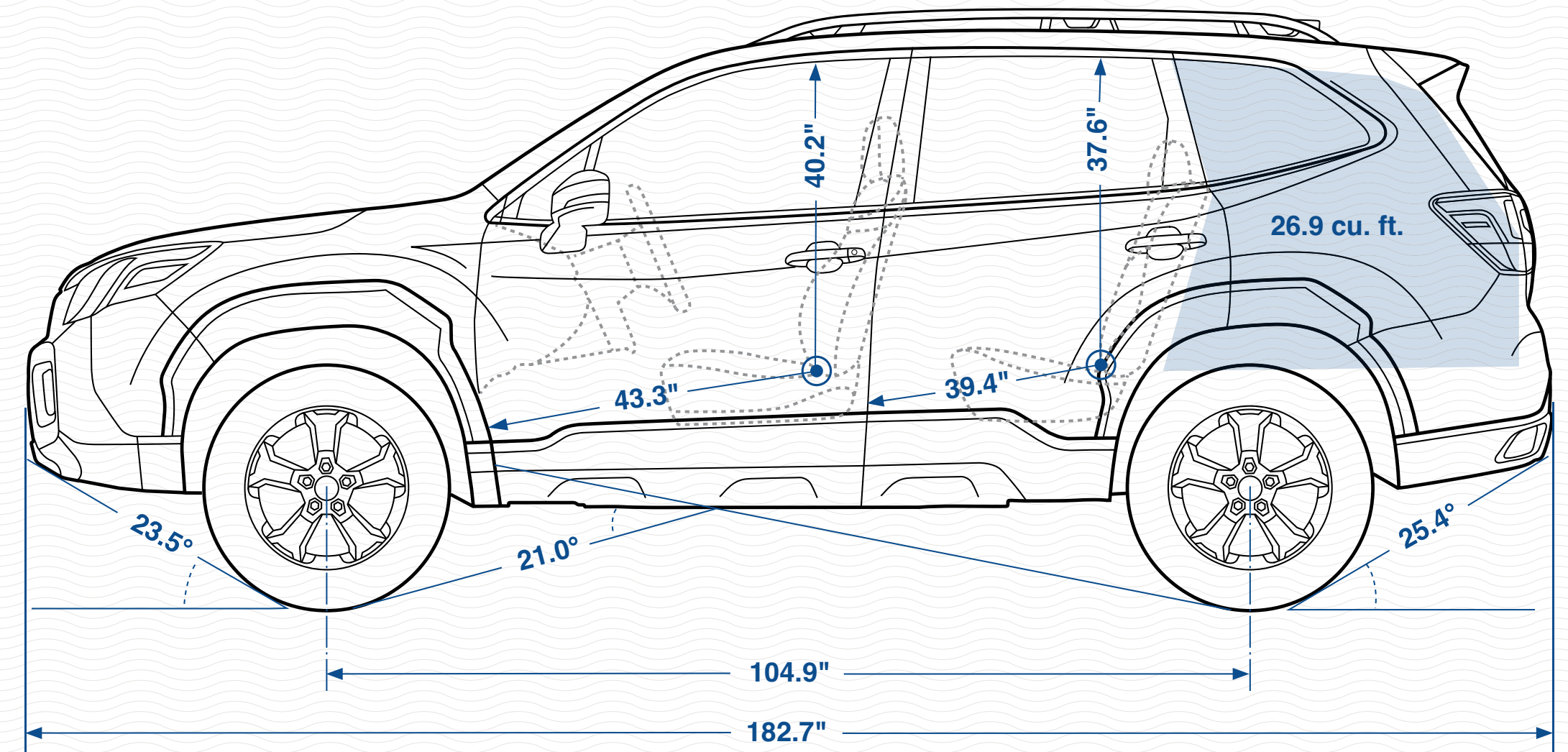
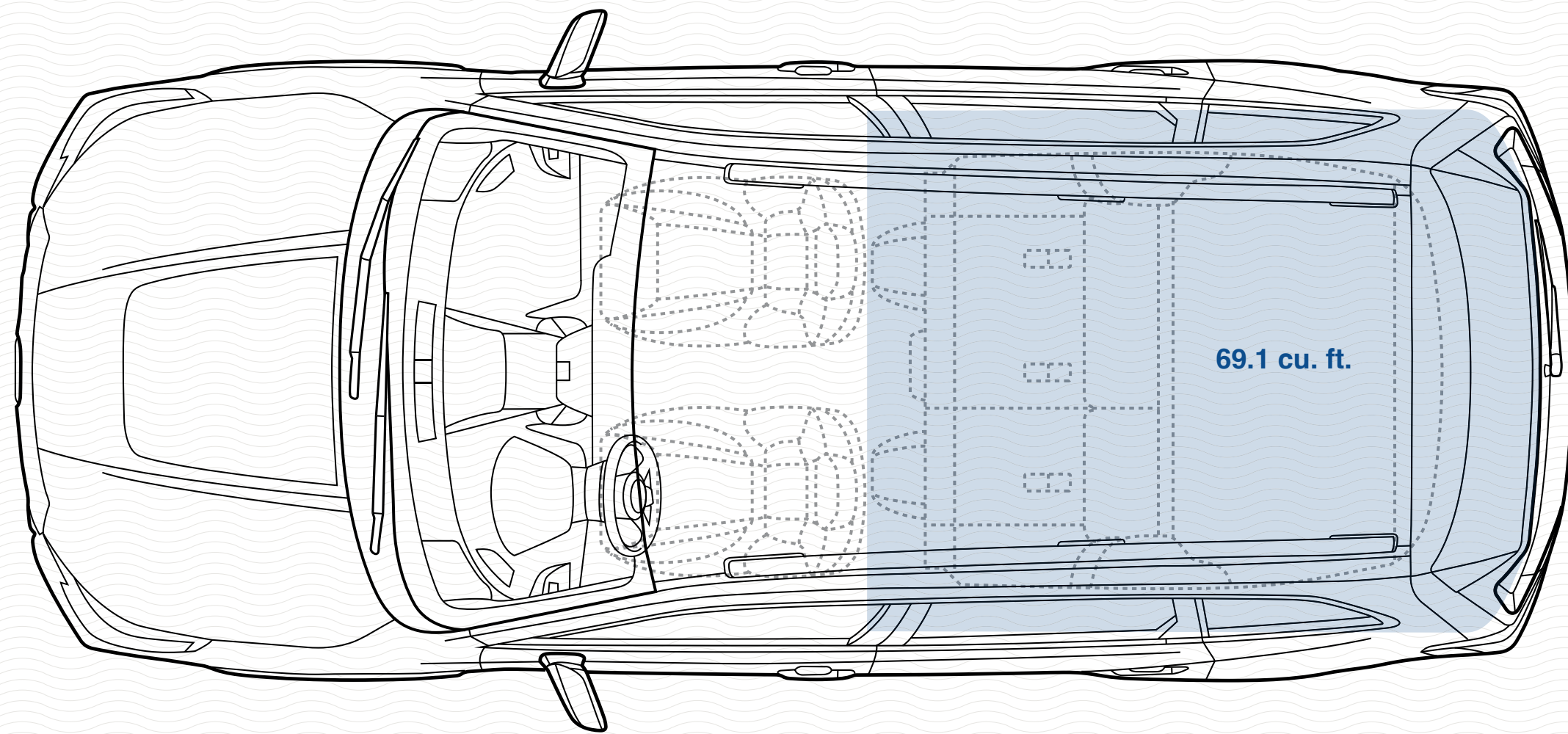

Length	182.7 inches
Width	72.2 inches (81.3 inches with exterior mirrors)
Height	68.9 inches
Wheelbase	104.9 inches
Track (front/rear)	61.4 inches/61.4 inches
Base curb weight	3,620 lbs.
Ground clearance	9.2 inches
Headroom (front/rear)	40.2 inches/37.6 inches
Legroom (front/rear)	43.3 inches/39.4 inches
Shoulder room (front/rear)	58.1 inches/57.2 inches
Hip room (front/rear)	54.5 inches/53.5 inches
Passenger volume	107.6 cubic feet
Cargo volume	26.9 cubic feet
Maximum cargo volume	69.1 cubic feet

1 EyeSight is a driver assist technology, which may not operate optimally under all driving conditions. The driver is always responsible for safe and attentive driving. System effectiveness depends on many factors such as vehicle maintenance, weather and road conditions. The Pre-Collision Braking System is designed to provide automatic braking that either prevents a collision or reduces the severity of a frontal impact. Pre-Collision Throttle Management is designed to reduce acceleration and minimize the severity of certain frontal impacts. Advanced Adaptive Cruise Control, Brake Light Recognition and Automatic Emergency Steering are designed to assist the driver and are not substitutes for safe and attentive driving. Automatic Emergency Steering availability varies by trim level and works in conjunction with and after Pre-Collision Braking has been activated by providing steering support at speeds lower than 50 mph to try and help avoid a collision. Lane centering function operates only when used in conjunction with Advanced Adaptive Cruise Control. The Lane Departure and Sway Warning operates only when the lane markings are visible, and its effectiveness depends on many factors. See your Owner's Manual for complete details on system operation and limitations. 2 Trailer brakes may be needed. Some safety features, including X-MODE, Blind-Spot Detection and Rear Cross-Traffic Alert, may not function properly when towing. See your Subaru retailer for details. 3 Roof tents may be used in certain conditions. Consult Owner's Manual for important safety information and requirements. 4 Availability varies by trim level. See your Subaru retailer for details. 5 Activation and subscription required. Internet access is purchased separately through AT&T with monthly, per gigabyte, and unlimited data options available. Existing AT&T customers have the option to add a line to their AT&T Mobile Share plan. See your Subaru retailer for details. 6 Automatic Emergency Steering requires Blind-Spot Detection. Availability varies by trim level. See your Subaru retailer for details. 7 Blind-Spot Detection, Lane Change Assist and Rear Cross-Traffic Alert are systems designed to assist the driver by monitoring the rear and side areas of the vehicle during a lane change or reversing and are not a substitute for safe and attentive driving. 8 The Reverse Automatic Braking System is not a substitute for safe and attentive driving. System effectiveness depends on many factors, such as vehicle maintenance, weather and road conditions. Always exercise caution and use vehicle mirrors and the Rear-Vision Camera when backing up. See your Owner's Manual for complete details on system operation and limitations. 9 Activation with subscription required. Includes a 3-year trial subscription to Safety Plus services and a 6-month trial subscription to Safety and Security Plus services. The Concierge plan can be purchased annually or monthly. A credit card on file will be required for specific packages and for renewal purposes. Not available in all states. See your Subaru retailer for details. 10 2023 IntelliChoice 5-Year Cost of Ownership Study © 2024 MOTOR TREND GROUP, LLC. 11 Based on Experian Automotive vehicles in operation vs. total new registrations for MY2014-2023 as of December 2023. 12 Compared to all other measured mass-market automotive companies in the 2023 American Customer Satisfaction Index (ACSI®) surveys of customers rating their own automotive company's performance. ACSI and its logo are registered trademarks of the American Customer Satisfaction Index, LLC. 13 All SiriusXM services require a subscription, sold separately by SiriusXM after the trial period. Your SiriusXM service will automatically stop at the end of your trial unless you decide to subscribe. If you decide to continue service, the subscription plan chosen will automatically renew and be charged according to your chosen payment method at the then-current rates. Fees and taxes apply. See the SiriusXM Customer Agreement & Privacy Policy at www.siriusxm.com for full terms and how to cancel, which includes online methods or calling 1-866-635-2349. Available in the 48 contiguous United States, D.C., and Puerto Rico (with coverage limits and capable receiver). Visit www.siriusxm.com/FAQS for most current service area information. Availability of some services and features is subject to device capabilities and location restrictions. All fees, content and features are subject to change. SiriusXM, SiriusXM Traffic, SiriusXM Travel Link® and all related logos are trademarks of Sirius XM Radio Inc. and its respective subsidiaries. Other marks, channel names and logos are the property of their respective owners. All rights reserved. 14 All SiriusXM services require a subscription, each sold separately by SiriusXM after the trial period. Service subject to the SiriusXM Customer Agreement and Privacy Policy, visit www.siriusxm.com for complete terms and how to cancel which includes online methods or calling 1-866-635-2349. Some services and features are subject to device capabilities and location availability. Satellite service not available in AK & HI. Content varies by SiriusXM subscription plan. All fees, content and features are subject to change. SiriusXM and related logos are trademarks of Sirius XM Radio Inc. and its respective subsidiaries.

Some images shown are for illustration purposes only. Specifications and imagery in this brochure are based on the latest product information available at the time of publication. Production models may vary. For the most up-to-date and detailed product information, log on to www.subaru.com. Some equipment shown in photography in this brochure is optional at extra cost. Specific options may be available only in combination with other options. Specific combinations of equipment or features may vary from time to time and by geographic area. Certain accessories and equipment may not be available at the time of publication. Subaru of America, Inc., reserves the right to change or discontinue at any time, without notice, prices, colors, materials, equipment, accessories, specifications, models and packages without incurring any obligation to make the same or similar changes on vehicles previously sold. Colors shown may vary due to reproduction and printing processes.

This brochure was prepared by Subaru of America, Inc. EyeSight, Lineartronic, SI-DRIVE, Subaru, STARLINK, SUBARU BOXER, SUBARU STARLINK, X-MODE and Wilderness are registered trademarks of Subaru Corporation. Forester, Love. It's what makes Subaru, Subaru., and StarTex are registered trademarks of Subaru of America, Inc. ACSI® and its logo are registered trademarks of The American Customer Satisfaction Index, LLC. Apple CarPlay® is a registered trademark of Apple, Inc. Bluetooth® is a registered trademark of Bluetooth SIG, Inc. Experian® is a registered trademark of Experian Information Solutions, Inc. Google, Android, Android Auto, and Google Play are trademarks of Google LLC. Harman Kardon® is a registered trademark of Harman International Industries, Incorporated. Honda® is a registered trademark of Honda Motor Co., LTD. Motor Trend® and IntelliChoice® are registered trademarks of Motor Trend Group, LLC. SiriusXM, SiriusXM Traffic, SiriusXM Travel Link® and all related logos are trademarks of Sirius XM Radio Inc. and its respective subsidiaries. Other marks, channel names and logos are the property of their respective owners. All rights reserved. Thule® is a registered trademark of the Thule Group. Toyota® is a registered trademark of Toyota Motor Corporation. Yokohama® and Geolandar® are registered trademarks of Yokohama Tire Company. For more information, contact your Subaru retailer, or log on to www.subaru.com.

Love. It's what makes Subaru, Subaru.®

