



VOLVO
S60R AND V70R 2005

VOLVO
for life





R



MORE POWER.

MORE INTELLIGENCE.

MORE DESIGN.

GIVE IN TO YOUR DESIRES IN THE VOLVO S60 R AND V70 R.

VOLVO S60 R

THE ENTICING SPORTS SEDAN – AWESOME PERFORMANCE,
AND LONG-DISTANCE COMFORT FOR UP TO FIVE PEOPLE.







VOLVO V70 R

THE SPIRITED SPORTS WAGON – A HIGH-PERFORMANCE
DRIVING EXPERIENCE, WITH CONVENIENCE FOR WHATEVER
YOUR LIFESTYLE DEMANDS.



IT ALL STARTS AS YOU GRASP THE LEATHER-TRIMMED R STEERING WHEEL ... AS YOU FEEL THE DISTINCT YET PLIANT SUPPORT FROM THE SCULPTED LEATHER SPORTS SEAT ... START THE ENGINE ... THRILL TO THAT INSPIRING SOUND ... SELECT THE MOST SPIRITED CHASSIS MODE ... TAKE OFF ... SENSE THE UNCOMPROMISING TRACTION ... THE ACCELERATION ... THE G-FORCE – ALL THE WHILE KNOWING THAT THE SERIOUS FUN HAS ONLY JUST BEGUN.





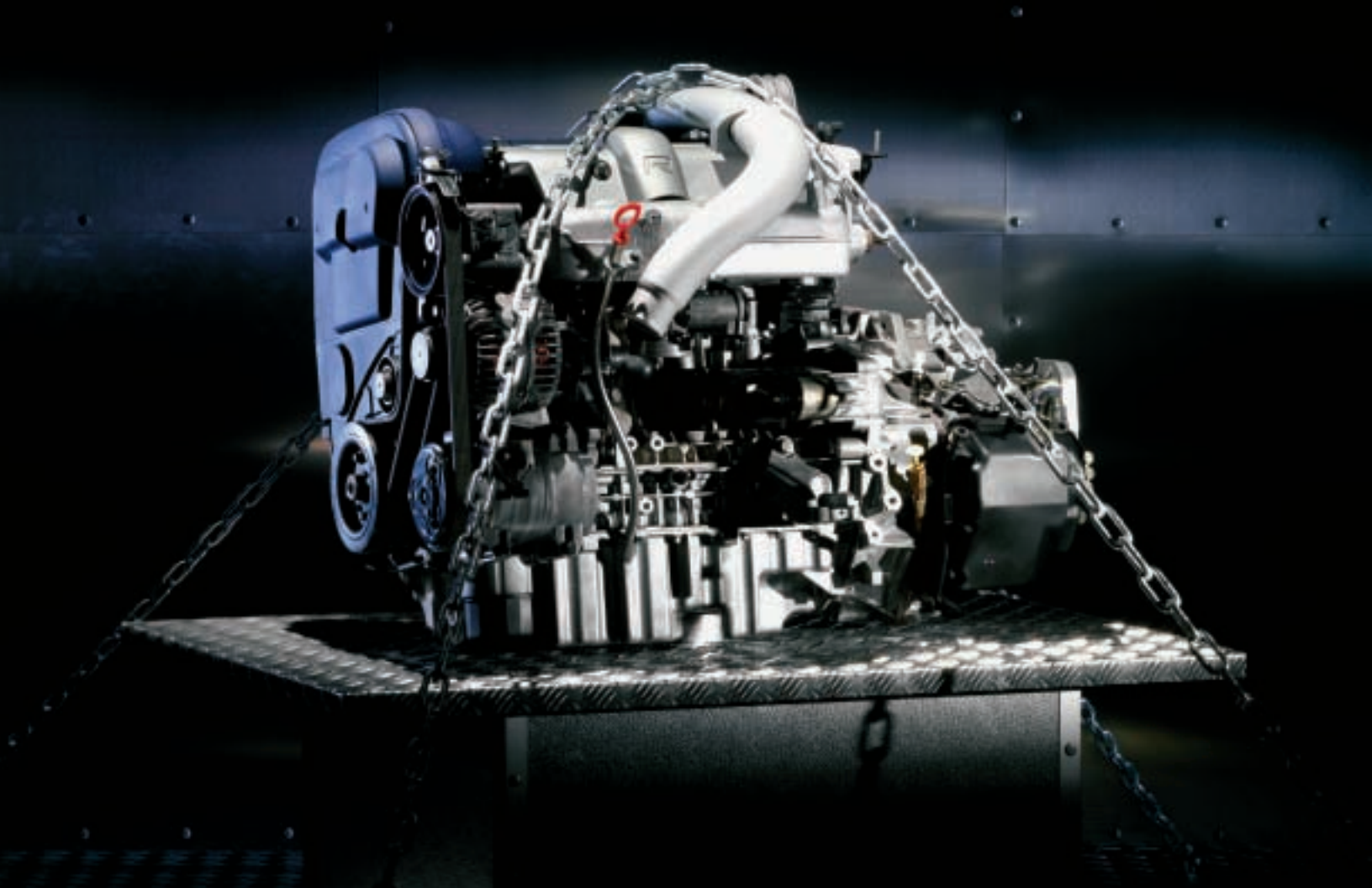

THE R FORCE

THE VOLVO S60 R AND V70 R WELCOME YOU TO A TRULY THRILLING DRIVING EXPERIENCE, AND THE FIVE-CYLINDER 300-HP TURBOCHARGED POWERPLANT IS MORE THAN WILLING TO SET THE PACE. ADD THE FOUR-C CHASSIS TECHNOLOGY, ELECTRONICALLY CONTROLLED ALL-WHEEL DRIVE, SOPHISTICATED SUSPENSION SYSTEMS AND BREMBO BRAKES – THOSE THREE HUNDRED HORSES ARE FULLY UNDER YOUR CONTROL.

THE ENGINE

The Volvo S60 R and V70 R are the fastest cars we've ever built. The five-cylinder 2.5-liter turbocharged engine produces 300 hp at 5,500 rpm and offers 295 ft./lbs of torque at 1,950–5,250 rpm (manual) or 258 ft./lbs at 1,850–6,000 rpm (automatic), taking you from 0 to 60 mph in 5.4 seconds (Volvo S60 R) or 5.6 seconds (Volvo V70 R) with the manual transmission. Continuously variable valve timing on both the intake and exhaust sides (Dual CVVT) contributes to surging performance – whatever the engine speed. At the same time, exhaust emissions are surprisingly low, even during cold starts. Dual intercoolers, dual fuel pumps, a two-section fuel tank, and a specially designed oil pan are racing-inspired features that round off a highly potent power plant designed to handle the G-forces that build up as you get serious with the accelerator. And yet the engine is also characterized by a high degree of elegant refinement – the smooth operation and the uniform flow of power across the entire range of engine speeds make this engine truly enjoyable in more everyday driving situations.

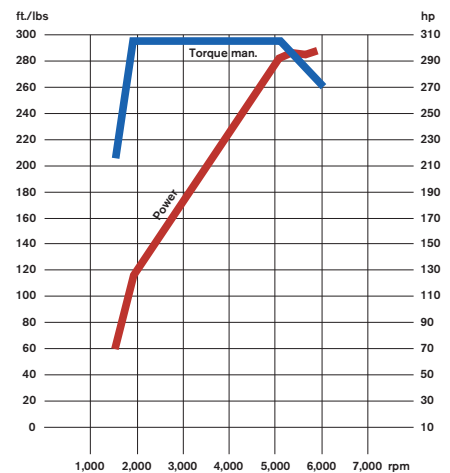

AWD

THE AWD SYSTEM. Drive is continuously distributed between the front and rear wheels by the electronically controlled all-wheel drive-system (AWD). The front wheels normally get 95% of all driving force. As the situation dictates, however, up to 70% of this force is redirected at lightning speed to the rear wheels. The system responds extremely quickly, making it possible to balance understeering and oversteering tendencies with exceptional precision. For example, during rapid acceleration or fast cornering, drive is redistributed seamlessly between the front and rear wheels within a fraction of a second – depending on what is needed to provide maximum driving stability. Behind the wheel, you'll never be aware when the AWD system engages and disengages – you'll just enjoy that superb feeling of total control.



THE STEERING. The quick and responsive steering is the key point of contact between man, machine, and the road. You can enjoy speed-sensitive power steering, which progressively reduces power assistance as road speed increases, allowing the driver to receive optimum feedback from the road.



THE TRANSMISSION. The close-ratio six-speed manual transmission features a quick, crisp and positive action for fast and precise shifting. If you prefer the more relaxed five-speed Geartronic auto-shifter which also allows manual shifting, you can still prioritize sporty progress by selecting a sports mode that offers faster gear-shifting. Geartronic can also maintain a lower gear, for example to provide added engine braking as you approach a bend or curve.



THE BRAKES. Four-piston aluminum Brembo brake calipers engage the 13 inch ventilated discs to provide immediate braking force. Forging the calipers in light alloy aids heat dissipation – with minimum brake fade even after repeated hard use. This together with lightweight aluminum wheels promotes a low unsprung weight, which in turn boosts the car's crisp and precise driving manners.

THE R INTELLIGENCE

THE MASSIVE POWER IS A PLEASURE WHEN YOU CAN CONTROL IT. VOLVO'S REVOLUTIONARY FOUR-C CHASSIS TECHNOLOGY PUSHES THE ENVELOPE – AND ALLOWS YOU TO RETURN FROM YOUR DRIVE WITH A SMILE OF PURE ENJOYMENT. A TOUCH OF A BUTTON AND YOU SHIFT INSTANTLY FROM RELAXED PROGRESS AND EVERYDAY COMMUTING TO A PULSE-QUICKENING, URGENT RACING PACE. JUST PICK THE TIME, PLACE AND PERFORMANCE LEVEL – THE VOLVO S60 R AND V70 R WILL RESPOND INSTANTLY TO YOUR WISHES.





COMFORT. When the road is slippery, or when you just want a relaxing drive – the Comfort chassis mode helps insulate the car from irregularities in the road surface. The system prioritizes low damping motion for a smoother ride.



SPORT. For a taut but supple everyday sports car feel. The system prioritizes somewhat harder damping and faster activation than in the Comfort mode. Results in well-damped body movements and precise road behavior with good riding comfort.



ADVANCED. Uncompromising chassis mode for maximum performance, control and traction. The chassis stops ironing out the bumps in the road, and starts telegraphing every single piece of road information directly to the driver. With very hard damping to ensure maximum contact between tire and road. Provides maximum roadholding for track use and in advanced high-speed driving where traction has higher priority than riding comfort. And when you've had your fun, comfort is at your fingertips ...



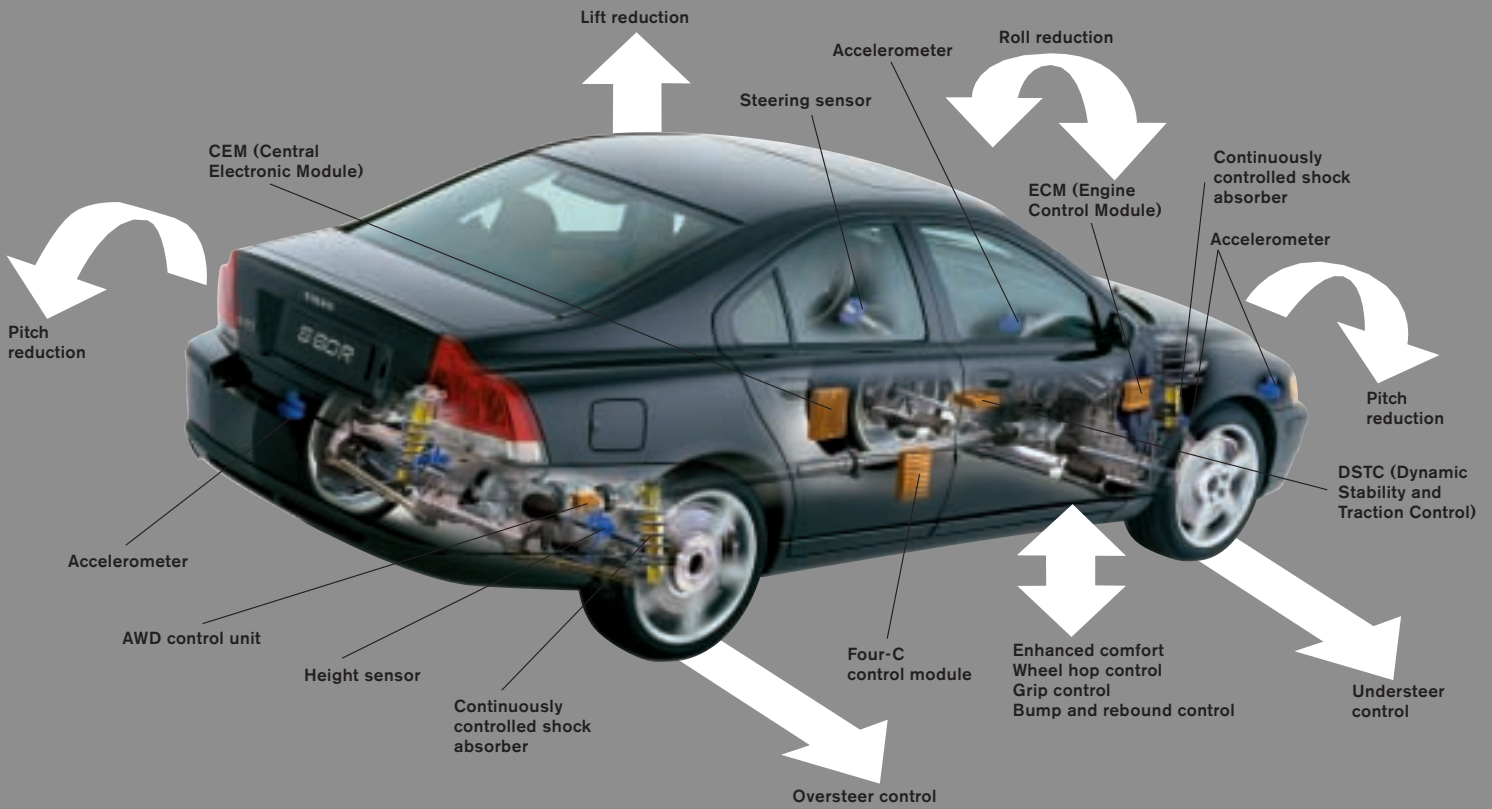

THE PHILOSOPHY BEHIND THE VOLVO S60 R AND V70 R IS TO TURN THE LAWS OF PHYSICS INTO UNADULTERATED FUN. HERE ARE SOME EXAMPLES OF HOW FOUR-C TECHNOLOGY INTERACTS WITH THE ALL-WHEEL DRIVE SYSTEM IN DIFFERENT DRIVING SITUATIONS. AND BECAUSE ALL CURVES ARE DIFFERENT, THE CAR'S SETUP CHANGES ACCORDINGLY – TO GIVE YOU MAXIMUM ENJOYMENT BEHIND THE WHEEL.

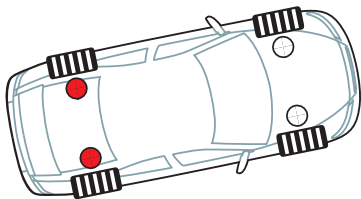

ACCELERATION

The car transfers more power to the rear wheels and increases rear shock absorber damping to ensure maximum take-off performance.

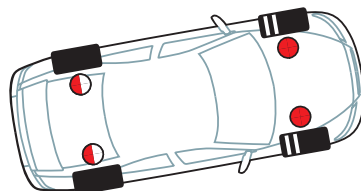

BRAKING

The moment you touch the brake pedal, the car disengages drive to the rear wheels and adjusts damping of both the front and rear wheels, preparing itself to ensure optimum braking performance, minimum body pitch, and stable roadholding throughout the braking sequence.

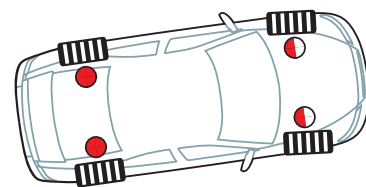

ENTERING A CURVE

As the car enters the curve, the Active Performance Chassis responds by increasing the damping of both sets of wheels to increase body control. A hint of oversteer is induced by the shock absorbers and more power is transferred to the rear wheels for a fast turn-in. And to reduce understeer when turning further into the curve and help keep a balanced line throughout the turn, the chassis decreases damping at the front wheels.

● = Shock absorber, maximum damping

○ = Shock absorber, minimum damping

THE ACTIVE HIGH-PERFORMANCE CHASSIS WITH FOUR-C TECHNOLOGY IS THE SECRET BEHIND THE UNIQUE PROPERTIES IN OF THE VOLVO S60 R AND V70 R. FOUR-C GIVES ACTIVE DRIVING AN ENTIRELY NEW MEANING. THE CAR IS ALWAYS PREPARED – ALMOST BEFORE THE DRIVER – TO DEAL WITH THE FORCES OF NATURE AS THE GOING GETS MORE EXCITING.

Volvo's active high-performance chassis with Four-C (Continuously Controlled Chassis Concept) technology gives you maximum interactivity for optimal driving enjoyment. It is a semi-active suspension system with continuously controlled shock absorbers by Monroe-Öhlins, featuring three dynamic chassis modes (Comfort, Sport and Advanced). As you drive, the system collects huge amounts of information about the way the car moves and behaves. It analyses the information and responds

instantly by adjusting each shock absorber individually to suit the road and driving conditions. All this takes place with extreme precision up to 500 times a second. Moreover, the Active Performance Chassis with Four-C Technology interacts dynamically with the all-wheel drive, the DSTC system, the engine, the brakes, the steering and other functions – all to maximize response and match the handling characteristics to the driving style you choose.

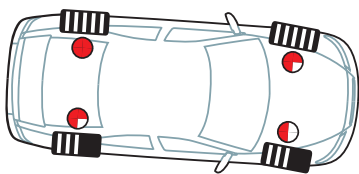

MID-CURVE

At the apex of the curve, when cornering forces are at their greatest and the driver wants the car to start accelerating, power is transferred to all the wheels – according to their level of traction – while the chassis minimizes roll and constantly balances over- and understeering.

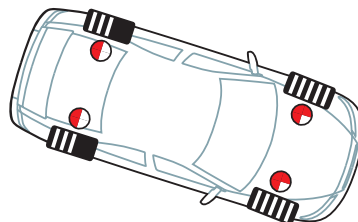

EXITING A CURVE

When exiting the curve and the driver puts his foot down, the damping of the front wheels – and the amount of power – is increased to maintain stability.

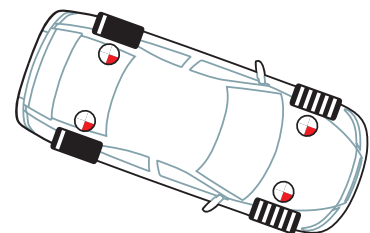

DRIVING AHEAD

The Four-C system continually analyzes speed, wheel movements, steering wheel position and other parameters, adjusting each shock absorber individually at lightning speed to suit the road and driving conditions. You drive brilliantly ... and there's still more beyond the next corner ... and the next ... and the next ...

 = Driving wheel, maximum traction

 = Driving wheel, minimum traction

"CARS ARE DRIVEN BY PEOPLE. THE GUIDING PRINCIPLE
BEHIND EVERYTHING WE MAKE AT VOLVO, THEREFORE,
IS – AND MUST REMAIN – SAFETY."

ASSAR GABRIELSSON AND GUSTAF LARSON,
THE FOUNDERS OF VOLVO.



THE R SAFETY

THE VOLVO S60 R AND V70 R ARE DESIGNED TO PROVIDE COMPLETE DRIVER CONFIDENCE AND OCCUPANT PROTECTION. AN ERGONOMIC DRIVER'S ENVIRONMENT AND SOPHISTICATED TECHNOLOGY MAKE IT EASIER TO PREDICT AND AVOID POTENTIALLY DANGEROUS TRAFFIC SITUATIONS. THE FOUR-C CHASSIS, ALL-WHEEL DRIVE AND ACTIVE STABILITY-ENHANCING SYSTEMS HELP GIVE YOU CONTROL UNDER A WIDE VARIETY OF CHALLENGING CONDITIONS. AND SHOULD AN ACCIDENT BE UNAVOIDABLE, YOU AND YOUR PASSENGERS ARE PROVIDED ENHANCED PROTECTION BY ONE OF THE AUTOMOTIVE WORLD'S MOST EFFECTIVE SAFETY SYSTEMS. THE VOLVO S60 R AND V70 R STAND ALONE IN THEIR CLASS – ALLOWING YOU TO ENJOY THE R EXPERIENCE TO THE FULL.

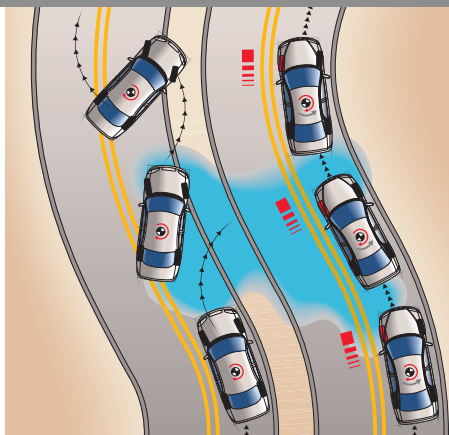

DSTC (Dynamic Stability and Traction Control) increases driving safety on twisting roads and in slippery conditions. If one of the driven wheels shows any tendency to lose traction, power to that wheel is cut at lightning speed so it can quickly regain grip. Any tendency to skid is countered instantaneously, smoothly and effectively by the DSTC system braking one or more wheels and reducing the engine's power output – all depending on what is needed for helping you to maintain control. At the touch of a button, you can even re-profile the system to permit a certain degree of skidding before it engages. And if you're in the mood for maximum driving entertainment, you can disengage certain functions of the DSTC system.

As darkness falls, you will appreciate the powerful and effective low and high beams. Bi-Xenon headlights mean you can enjoy an exceptional broad, long, and pleasant beam of light in all conditions. Low beam height is automatically adjusted to provide the best possible light pattern even when the car is heavily loaded. Integrated front and rear side-marker lights make it easier for other road-users approaching from the side to see your car.

INTERACTIVE SAFETY SYSTEMS

The advanced safety systems in a Volvo work together to help create a safe environment for you and your passengers. The front and rear crumple zones dissipate and distribute incoming collision forces to help reduce the effects on the car's occupants. The robust safety cage is designed as an interactive web of steel beams that surround the occupants to help withstand crash forces. The airbags are designed to adapt their inflation pattern to suit the crash forces and work together as a system with the seat belts and pre-tensioners.

In an impact from the side, Volvo's SIPS (Side Impact Protection System) distributes crash forces across a larger part of the car's body to help reduce the strain on the occupants. The side airbags in the front seats interact with the IC (Inflatable Curtain) to help provide maximum protection. And if the car is hit from behind, Volvo's unique front-seat whiplash protection system helps reduce the strain on the spine and neck.

THE R DESIGN

EXTENDED FRONT SPOILER FOR GREATER DOWNWARD THRUST. ENLARGED AIR DUCT TO COOL THE 300 HP ENGINE. AERODYNAMIC FRONT WITH BI-XENON HEADLAMPS AND PROJECTOR TYPE FRONT FOG LAMPS. R ALUMINUM WHEELS. SUBTLE REAR SPOILER TO REDUCE REAR LIFT BY 20% ON THE VOLVO S60 R. NO GRAND GESTURES. JUST EFFICIENT DESIGN THAT DOES THE JOB – ON THE ROAD OR ON THE TRACK.



Shown with optional Sport Body Package. >





“**GOOD DESIGN** IS NOT ONLY A MATTER OF STYLING THE SURFACE. IT IS JUST AS IMPORTANT TO MAKE THE PRODUCT EASY TO UNDERSTAND AND USE. IF THE PRODUCT IS NOT FUNCTIONAL, IT CAN'T BE BEAUTIFUL.”
(THE VOLVO DESIGN PHILOSOPHY)

^
Shown with optional Sport Body Package. >







THE VOLVO S60 R FACTS

ENGINE

In-line 2.5-liter five-cylinder high-pressure turbo engine with CVVT (Continuously Variable Valve Timing) on both the exhaust and intake sides. Double overhead camshafts, 20 valves. Dual charge-air coolers (Intercoolers). Three-way catalytic converter with Lambda sensor.

Power: 300 hp at 5,500 rpm (manual) or 6,000 rpm (automatic)

Torque: 295 ft./lbs at 1,950–5,250 rpm (manual) or 258 ft./lbs at 1,850–6,000 rpm (automatic)

Acceleration 0–60 mph, man/auto: 5.4/7.2 sec

Top speed: 155 mph (electronically controlled)

Environmental classification: ULEV

DRIVELINE

Electronically-controlled AWD all-wheel drive with TRACS anti-spin system. Six-speed manual close-ratio gearbox (Sports gear-shift lever, aluminum with leather-clad gear-lever knob). Also available with a five-speed Geartronic automatic transmission which allows sequential manual shifting (leather-clad gear-lever knob).

CHASSIS

Four-C (Continuously Controlled Chassis Concept) semi-active chassis with three driving modes (Comfort, Sport and Advanced Sport). Front suspension with spring struts. Multi-link independent rear suspension with aluminum subframe. Anti-roll bars front (0.93 inches) and rear (0.79 inches). DSTC (Dynamic Stability and Traction Control) anti-skid system that can be partially disengaged.

BRAKES

Power-assisted ABS brakes, ventilated 13 inch discs front and ventilated 13 inch discs rear. Brembo four-piston aluminum calipers. Featuring EBA (Emergency Brake Assistance) and EBD (Electronic Brake Distribution) between front and rear brakes. Stopping distance 60-0 mph: 118 ft.

STEERING

ZF Servotronic speed-dependent power-assisted rack and pinion steering. Smooth steering wheel adjustment for rake and reach. 2.5 turns lock-to-lock. Steering gear ratio reduced by 5.6% from standard S60. This provides more responsive steering.

WHEELS*

Pegasus 8x17" 5-spoke aluminum wheels, Pirelli P-Zero Rosso 235/45-17" tires.

Optional Pegasus 8x18" 5-spoke aluminum wheels, Pirelli P-Zero Rosso 235/40-18" tires.

HEADLAMPS

Bi-Xenon headlamps, Silver Bezel. Projector type front fog lamps.

DRAG COEFFICIENT

Cd 0.29.

SAFETY

Three-point seat belts with pre-tensioners on all five seats. Dual-stage airbags. SIPS – Volvo's Side Impact Protection System with side airbags and IC (Inflatable Curtain). WHIPS – Volvo's Whiplash Protection System. ISOFIX child safety equipment installation system.

SECURITY

Electronic immobilizer. Remote-controlled central locking. Approach and Home Safe lighting. A remote-controlled alarm with panic button is standard.

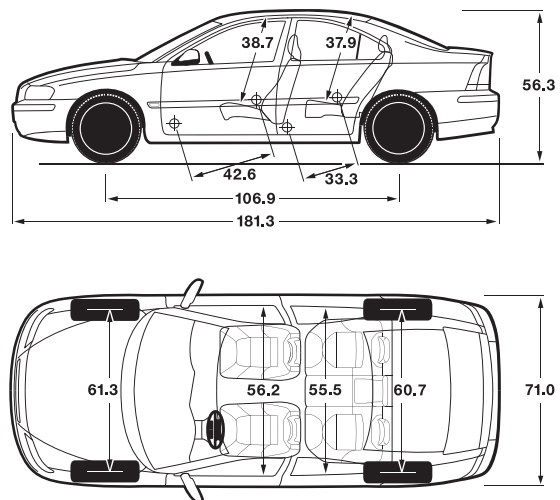



THE VOLVO V70 R FACTS

ENGINE

In-line 2.5-liter five-cylinder high-pressure turbo engine with CVVT (Continuously Variable Valve Timing) on both the exhaust and intake sides. Double overhead camshafts, 20 valves. Dual charge-air coolers (Intercoolers). Three-way catalytic converter with Lambda sensor.

Power: 300 hp at 5,500 rpm (manual) or 6,000 rpm (automatic)

Torque: 295 ft./lbs at 1,950–5,250 rpm (manual) or 258 ft./lbs at 1,850–6,000 rpm (automatic)

Acceleration 0–60 mph, man/auto: 5.6/7.4 sec

Top speed: 155 mph (electronically controlled)

Environmental classification: ULEV

DRIVELINE

Electronically-controlled AWD all-wheel drive with TRACS anti-spin system. Six-speed manual close-ratio gearbox (Sports gear-shift lever, aluminum with leather-clad gear-lever knob). Also available with a five-speed Geartronic automatic transmission which allows sequential manual shifting (leather-clad gear-lever knob).

CHASSIS

Four-C (Continuously Controlled Chassis Concept) semi-active chassis with three driving modes (Comfort, Sport and Advanced Sport). Front suspension with spring struts. Multi-link independent rear suspension with aluminum subframe. Anti-roll bars front (0.93 inches) and rear (0.89 inches). DSTC (Dynamic Stability and Traction Control) anti-skid system that can be partially disengaged.

BRAKES

Power-assisted ABS brakes, ventilated 13 inch discs front and ventilated 13 inch discs rear. Brembo four-piston aluminum calipers. Featuring EBA (Emergency Brake Assistance) and EBD (Electronic Brake Distribution) between front and rear brakes. Stopping distance 60-0 mph: 118 ft.

* WHEELS AND TIRES

The Volvo R Concept models come standard with an Ultra High Performance tire and wheel combination with a low sidewall aspect ratio. The design and tire compounds are engineered to provide maximum dry pavement performance with consideration for hydroplaning resistance. As such, they may be more susceptible to road hazard damage and, depending on driving conditions, may achieve a tread life of less than 20,000 miles. If the vehicle is to be driven in cold, snowy, or icy weather conditions, Volvo recommends the use of a suitable winter tire and wheel combination which will offer better traction under those circumstances. It is also important to note that, because they are designed for responsive handling, the tires may deliver lower overall ride comfort. It is important to regularly check inflation pressure to assure all tires meet Volvo's specifications, and to help reduce the chance of tire rim or vehicle damage.

STEERING

ZF Servotronic speed-dependent power-assisted rack and pinion steering. Smooth steering wheel adjustment for rake and reach. 2.5 turns lock-to-lock. Steering gear ratio reduced by 5.6% from standard V70. This provides more responsive steering.

WHEELS*

Pegasus 8x17" 5-spoke aluminum wheels, Pirelli P-Zero Rosso 235/45-17" tires.

HEADLAMPS

Bi-Xenon headlamps, Silver Bezel. Projector type front fog lamps.

DRAG COEFFICIENT

Cd 0.32.

SAFETY

Three-point seat belts with pre-tensioners on all five seats. Dual-stage airbags. SIPS – Volvo's Side Impact Protection System with side airbags and IC (Inflatable Curtain). WHIPS – Volvo's Whiplash Protection System. ISOFIX child safety equipment installation system.

SECURITY

Electronic immobilizer. Remote-controlled central locking. Approach and Home Safe lighting. A remote-controlled alarm with panic button is standard.

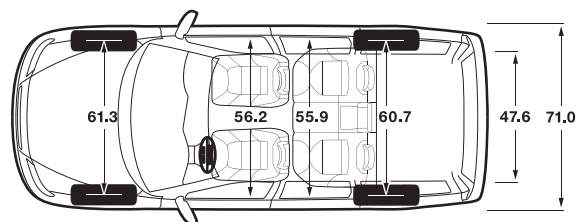
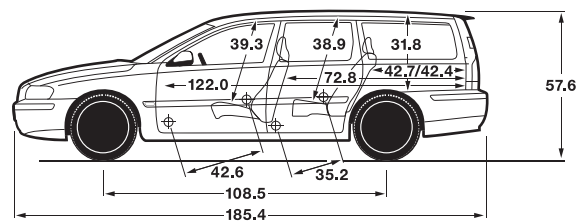

PREMIUM SOUND SYSTEM

Experience a world-class audio system for the truly discerning music-lover. Thirteen* Premium Sound speakers and Dolby Surround Pro Logic II® give audiophiles a moving experience, whether you're sitting in the front or rear seat – it's like having your favorite orchestra along for the ride. HU-850 in-dash RDBS radio with an integrated 6-CD changer, Dolby Surround Pro Logic II®, 13* Premium Sound speakers and a separate 300 W Premium Sound amplifier plus 25 W for the center speaker. Remote control from the steering wheel.

*11 speakers in V70 R

The Dolby and Pro Logic trademarks are the property of Dolby Laboratories Licensing Corporation.

VOLVO NAVIGATION SYSTEM

The Volvo Navigation System can guide you anywhere with precise audio and visual directions. Using the global positioning satellite system, a liquid crystal 6.5-inch display shows your location on a map and plots the best route. Controls are conveniently located on the steering wheel. When not in use, the screen retracts into the dashboard. All map-based information is stored on DVD.



THE R OPTIONS

THE SENSE OF QUALITY AND CARE – AND KNOWING THAT YOU GET THE VOLVO THAT SUITS YOUR LIFESTYLE. CUSTOMIZE YOUR CAR WITH THE OPTIONS THAT BEST MEET YOUR DEMANDS AND DESIRES, AND SOON YOU'LL BE BEHIND THE WHEEL OF YOUR INDIVIDUALLY TAILORED VOLVO.



POWER GLASS MOONROOF

Makes the interior feel extra light and airy. Touch a button – and you open or close the moonroof. And if the sun is too strong, you can always close the built-in sun shade.



INTEGRATED BOOSTER SEATS*

The outboard rear seats can be equipped with integrated booster cushions so the child always sits at the right height and enjoys a perfect view. And when not in use, they are easily folded down in the rear seat.

*Only available for V70 R.

ACCESSORIES

Volvo's accessories help you make your S60 R or V70 R even more suited to your personal needs. They are the only ones that have been tested to meet exacting safety, quality, and environmental requirements. You can also rest assured they're a perfect match to the technology and design of your Volvo.



PREMIUM PACKAGE

A Volvo offers you long, relaxed drives and a more spirited everyday life. The Premium Package will provide you with some necessities for that extra ambience and convenience.

- Power glass moonroof
- 325 watt premium audio system



CLIMATE PACKAGE

In a Volvo you're always prepared to deal with the ever-changing forces of nature. And to increase comfort when driving in cold, rain or snow – simply add the Climate Package.

- Heated front seats
- Rain sensor



TOURING PACKAGE

The wide range of considerate and practical features makes life with your Volvo a truly enjoyable experience. And by adding the Touring Package, you expand your freedom even more.

- Grocery bag holder
- Cargo protection net (V70 R)
- Cargo area 12V outlet (V70 R)
- Laminated side windows (water repellent glass)

EXTREME PERFORMANCE IS ALWAYS AT HAND,
WHENEVER YOU'RE IN THE MOOD. FOR THE
REST OF THE TIME, THE VOLVO S60 R OR V70 R
MAINTAINS ITS INTELLIGENT FUNCTIONALITY.
THE SEATS OFFER LUXURIOUS LONG-DISTANCE
COMFORT, THE STORAGE COMPARTMENTS ARE
SPACIOUS AND FLEXIBLE, AND THE PREVENT-
IVE AND PROTECTIVE SAFETY SYSTEMS ARE
OF ABSOLUTE WORLD CLASS. NOTHING HAS
BEEN SACRIFICED OR COMPROMISED. ONLY
REFINED. BECAUSE, AFTER ALL, IT'S A VOLVO.



INTERIOR DESIGN

You can choose between three different exclusive leather upholsteries, with either a natural or special soft finish. The door panels are upholstered in the same material as the seats. The arch above the instrument panel is trimmed in black leather with blue stitching. The rest of the instrument panel and the door panels are always in Charcoal with aluminum inlays. The textile mats are color-matched to the leather upholstery.



Nordkap soft leather upholstery Blue metallic (S60 R: 9576/V70 R: A576)



Gobi soft leather upholstery Beige metallic (S60 R: 9577/V70 R: A577)



Atacama natural hide upholstery (S60 R: 9675/V70 R: A675)

EXTERIOR DESIGN



612 Passion Red



455 Titanium Grey metallic



426 Silver metallic

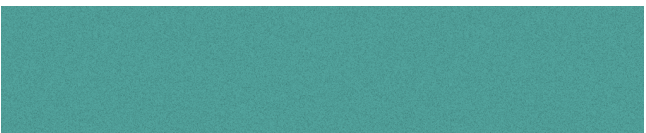

457 Flash Green metallic (special order)



452 Black Sapphire metallic

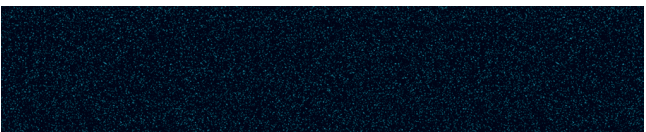

467 Magic Blue metallic



Pegasus 8x17"
Pirelli P-Zero Rosso
235/45-17" tires



Pegasus 8x18"
Pirelli P-Zero Rosso
235/40-18" tires
(S60 R)



Pegasus 8x18"
Titanium Grey
Pirelli P-Zero Rosso
235/40-18" tires
(S60 R)

WELCOME TO OUR FAMILY

BEING A VOLVO OWNER IS ABOUT MORE THAN JUST OWNING AN AUTOMOBILE. IT'S ABOUT BEING TREATED IN A CARING, RESPONSIVE AND RESPECTFUL MANNER EVERY TIME YOU INTERACT WITH OUR COMPANY. ALL OF US ARE COMMITTED TO MAKING EVERY ASPECT OF YOUR VOLVO EXPERIENCE A REWARDING ONE. SO AFTER THE NEW CAR SMELL BEGINS TO FADE, YOU'LL STILL BE EXCITED ABOUT OWNING A VOLVO.

**CARE
BY VOLVO**

VOLVO CAR FINANCE NORTH AMERICA

If you purchase or lease your Volvo through Volvo Car Finance North America, you can take advantage of services designed to make financing simple and convenient. Quick Debit, for instance, enables you to have your monthly payment automatically debited from a designated bank account. For more information, call 1-800-770-8234 or visit www.volvofinance.com

CARE BY VOLVO® ON CALL ROADSIDE ASSISTANCE

Whenever you need us, we're just a phone call away. Our nationwide network of retailers and authorized service providers are ready to assist. Whether you require roadside assistance or maps and routing information for your next trip, refer to your Care By Volvo® On Call Card and dial 1-800-63-VOLVO – anytime, day or night. Your complimentary four-year membership activates the moment you become a Volvo owner.

THE VOLVO OWNERS' CIRCLE

Driving is not the only rewarding part of owning a Volvo. As a member of the Volvo Owners' Circle, you'll have access to information designed exclusively for Volvo owners. This unique online resource includes frequently asked questions, special offers, a resale value wizard, and your own Virtual Glove Box – complete with an owner's manual and more.

VOLVO NEW CAR WARRANTY

Your new car warranty provides comprehensive coverage for four years or 50,000 miles, whichever occurs first. Additional warranties cover corrosion, seat belts, the supplemental restraint system, emission systems, genuine Volvo replacement parts and genuine Volvo accessories. Should you encounter any problem with your Volvo, simply contact the nearest retailer for assistance. Where your warranty ends, Volvo Increased Protection (VIP) plans begin. To purchase the additional protection of a VIP plan, contact your local retailer.

VOLVO OVERSEAS DELIVERY

VOLVO OVERSEAS DELIVERY OFFERS A UNIQUE WAY TO BUY YOUR NEW CUSTOM-BUILT CAR AS WELL AS A UNIQUE WAY TO SEE MORE OF EUROPE. AND WHEN YOU'RE DONE TRAVELING, BRING THE PLEASURE OF DRIVING A VOLVO BACK HOME. PURCHASE ANY NEW VOLVO AS PART OF THE VOLVO OVERSEAS DELIVERY PROGRAM AND ENJOY ALL THIS – AND MORE:

- Attractive pricing on US models
- Two complimentary round-trip tickets with Scandinavian Airlines.
- One free hotel night in Gothenburg, Sweden, the home of Volvo.
- An exciting Volvo Factory Tour or a visit to the new Volvo Cars Safety Center.
- An exclusive VIP delivery experience at the Volvo Factory Delivery Center.
- The opportunity to explore Europe in the comfort and safety of your own Volvo, either with one of our spectacular tours or on your own.
- Extensive complimentary home shipment services. Just leave your car with us. We'll ship it to you the convenient way while you relax and enjoy your complimentary flight back home.

VOLVO MOBILITY PROGRAM

The goal of the Volvo Mobility Program is to assist persons with physical disabilities or hearing impairment achieve independence. For those with exceptional transportation needs, freedom can be facilitated within the extraordinary comfort and safety of a specially adapted Volvo. For additional information on this program, please contact the Volvo Mobility Program Headquarters at (800) 803-5222 or visit www.volvocars.us/mobility. TTY users are invited to call 1-800-833-0312.

PERSONAL SHOPPER

The Volvo Personal Shopper is dedicated to providing you with a whole new level of shopping convenience. Whether you'd like help identifying the Volvo model that best fits your lifestyle, detailed information on any Volvo model, or a comparison against the competition, Volvo is there to help. We can arrange a Guest Drive for you at your nearest Volvo Retailer. So make the most of your shopping time and call the Volvo Personal Shopper at 1-800-550-5658. (U.S. only)

* Volvo Cars of North America, LLC is not an insurance company or agent. Its affiliate, American Road Services Company ("AMRO") and InsLogic Corporation ("InsLogic"), licensed insurance agencies provide all information regarding available insurance products. Insurance products are provided by non-affiliated participating insurance companies. Not all customers may qualify. In California, AMRO does business as American Road Insurance Agency and InsLogic does business as InsLogic Marketing Services Company.

Can you think of a better way of traveling overseas and making your souvenir part of an unforgettable experience?

If you would like to know more, contact your local Volvo retailer, our Customer Care Center (800) 631-1667, or visit www.volvocars.us/mybagsarepacked

WWW.VOLVOCARS.US

Specifications, features, and equipment shown in this catalog are based upon the latest information available at the time of publication. Volvo Cars of North America, LLC reserves the right to make changes at any time, without notice, to colors, specifications, accessories, materials, and models. For additional information, please contact your authorized Volvo retailer.

© 2004 Volvo Cars of North America, LLC. Printed in USA on recycled paper.

MY05H

VOLVO
Volvo Car Corporation