





mazda

ZOOM-ZOOM



3
YEAR
UNLIMITED KM
WARRANTY &
SERVICE PLAN

MAZDA BT-50

mazda.co.za     | The impossible made possible.



The Mazda BT-50 is built to take on any task, and to do it in style. It delivers grunt when you need it, and refined comfort with every drive. Fill it with gear, pull a load or take it off road. As a workhorse or a weekend warrior, it's always up to the challenge. The spacious cabin is a stylish surprise, with a level of passenger comfort that makes it feel more like a car. And, when it comes to your protection, safety features like 6 air bags, EBA and DSC ensure that you always feel secure behind the wheel. Equipped for work, play and everything in between, the Mazda BT-50 can do it all.

Powerful yet refined

When it comes to the Mazda BT-50, looks are just the beginning. Built for fun as much as it is for hard work, the exterior is bold and adventurous. With its refined features, it's a cut above others in its class. Styled with tough lines to match its solid capabilities, the bold new front is strong and powerful for a commanding street presence. The slightly lowered angle toward the front gives it a sense of forward motion – and the perfect balance of strong and sleek.

Bring it on

When it comes to performance, the Mazda BT-50 brings the goods. Built tough from the ground up, its ladder frame chassis provides reinforcement for maximum rigidity. The resulting stability can be felt in car-like handling, while the powerful engine makes towing light work. Harnessing the power is up to you - choose from a rugged 6-speed manual for complete control, or a versatile 6-speed auto that also allows for smooth manual changes.



2.2L ENGINE

Boosted by a variable geometry turbocharger to reduce lag, the 2.2L engine delivers 110kW and 375Nm using just 7.6L/100km (manual).



3.2L ENGINE

Feel the grunt of a five-cylinder engine with common-rail direct injection and intercooling. Pumping out 147kW and 470Nm of torque from 9.3L/100km (combined), you get effortless muscle for every task.



BODY

High-tensile steel is behind the the Mazda BT-50's durable body shell. Exceptionally strong, it also keeps overall weight down.



CHASSIS

Reinforced with a rigid ladder frame chassis, The Mazda BT-50 is ready to take on the heavy-duty jobs. Front wishbone suspension and rear leaf suspension cushion the ride for car-like handling on and off the road.



AUTOMATIC TRANSMISSION

Let the intelligent six-speed auto do the work for you, or step in for manual gear shifts when the mood strikes. In auto mode, Active Adaptive Shift (AAS) kicks in - intuitively changing gears to suit your driving conditions.



MANUAL TRANSMISSION

Enjoy the smooth ride of a six-speed manual that delivers fluid precision-shifting ratios. Transition through gear changes with ease for a true sense of control over your vehicle's performance.



A gutsy performance every time

Make the most of generous power with responsive performance. The Mazda BT-50 takes on the toughest challenges with effortless grunt, thanks to advanced common-rail direct injection. A variable geometry turbocharger reduces lag on the gutsy 2.2L, delivering an effortless 110kW and 375Nm of torque. Choose the 3.2L, and you get 147kW with an impressive 470Nm.

The strength to take on any challenge

The Mazda BT-50 is equipped with power, backbone and an enviable towing capacity of up to 3500Kg. Venture off the beaten track with the rugged 4x4 that's backed by the latest driver technology, making it easy to conquer uneven terrain. Jump between 2-High and 4-High at the flick of a switch without stopping the vehicle and get maximum traction on uneven terrain with electronic Locking Rear Differential (eLRD) that's operated via a console switch. Lock the rear wheels to evenly distribute torque between them, so if one loses grip, the other continues to provide power, turning the wheel to get traction on the ground.



Ready, willing and able

Whether it's navigating new terrain, carrying serious cargo or towing a few tons, The Mazda BT-50 handles it all without breaking a sweat.

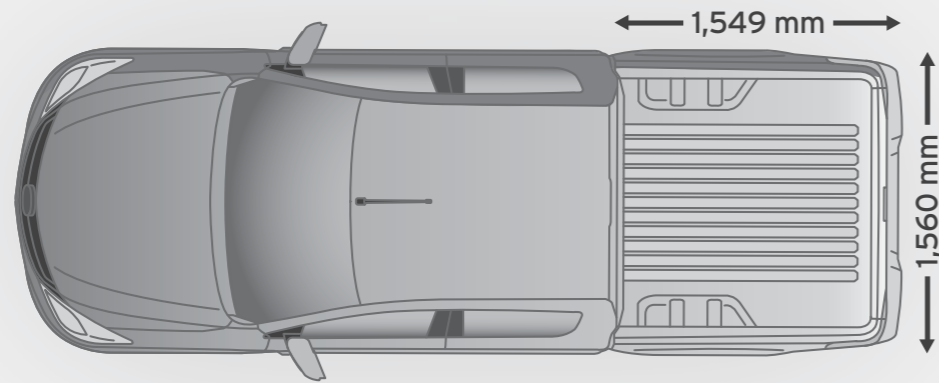

Room to move

Whether it's power, strength or capability, the Mazda BT-50 consistently delivers more. When it comes to space, it's no different. While the Mazda BT-50 boasts a generous cargo box in the back, you'll be surprised how much smart storage can be found around the cabin too. Tuck your gear away in the split-level centre console space, or the sizeable glove box that will hold a 16-inch laptop. Drinks and sunglasses have their own dedicated spaces, keeping them within grabbing reach on every trip.



The confidence of full protection

Feel confident driving a vehicle that's big on safety. Driver support begins with a rigid ride and accurate handling, giving you the capacity to avoid potential hazards. In the event the Mazda BT-50 does run into trouble, it's well equipped to deal with it. The reinforced body shell is fitted with front airbags and head-protecting curtain airbags in all models. Double Cab models also come with the addition of side (front) airbags. And when your cargo raises the Mazda BT-50's centre of gravity, you have Load Adaptive Control (LAC) for extra stability. Load Adaptive Control (LAC) is available on 4WD models only.

Dynamic Stability Control (DSC) helps keep traction in all conditions, managing the engine power and braking force delivered to individual wheels to avoid skidding or loss of grip. ABS brakes feature Electronic Brake-force Distribution (EBD) which matches braking to vehicle load, while Emergency Brake Assist (EBA) boosts stopping power when emergency braking is sensed. An Emergency Stop Signal (ESS) activates the hazard lights to warn following drivers of sudden deceleration.

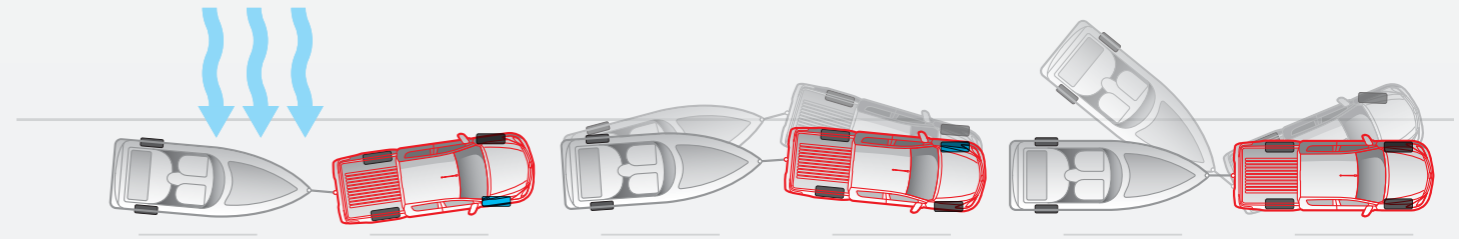

Safety reflex

Trailer Sway Control (TSC) adjusts braking and torque to correct any side-to-side swinging movement of towed loads. Available on 3.2L 4WD models only.

Better braking



Inclines made easy

Remove your foot from the brake on an incline and Hill Launch Assist (HLA) keeps the brakes applied, releasing them when there's enough power for a smooth start. While you're on steep slopes, you can engage Hill Descent Control (HDC) to maintain steady control of your speed. Standard on 3.2L 4WD models only.





MAZDA BT-50 DOUBLE CAB SLX

The Mazda BT-50 Double Cab features include:

BT-50 2.2 DE SLX 4x2

- Max power: 110kW @ 3700rpm
- Max torque: 375Nm @ 1500 - 2500rpm
- 6-Speed manual
- 6 Speakers
- 16" Alloy wheels
- Bluetooth®
- Integrated audio system
- Steering wheel switches
- Cruise control
- Locking Rear Diff (LRD)
- Tailgate lock
- Cloth seats
- Temperature display
- Front power windows
- Driver & front passenger airbag, seat side airbag & side curtain airbag
- Side step



MAZDA BT-50 DOUBLE CAB SLE

The Mazda BT-50 Double Cab features include:

BT-50 2.2 DE SLE 4x2

- 6-Speed manual/automatic transmission
- Dual zone ATC air conditioner
- Leather seats
- Chrome power windows
- Integrated audio system - high
- Headlamps auto on/off
- Rain sensing wipers
- Parking sensors
- Reverse camera
- Auto dimming mirror
- Electrical seat adjustment (Driver)

BT-50 3.2 DE SLE 4x4

- Max power: 147kW @ 3000rpm
- Max torque: 470Nm @ 1750 - 2500rpm
- Load Adaptive Control (LAC)
- Trailer Sway Mitigation
- Roll over Mitigation
- Hill Launch Assist (HLA)
- Hill Descent Control (HDC)



Space and style

Accommodate five adults comfortably in cloth seating, or select indulgent leather.

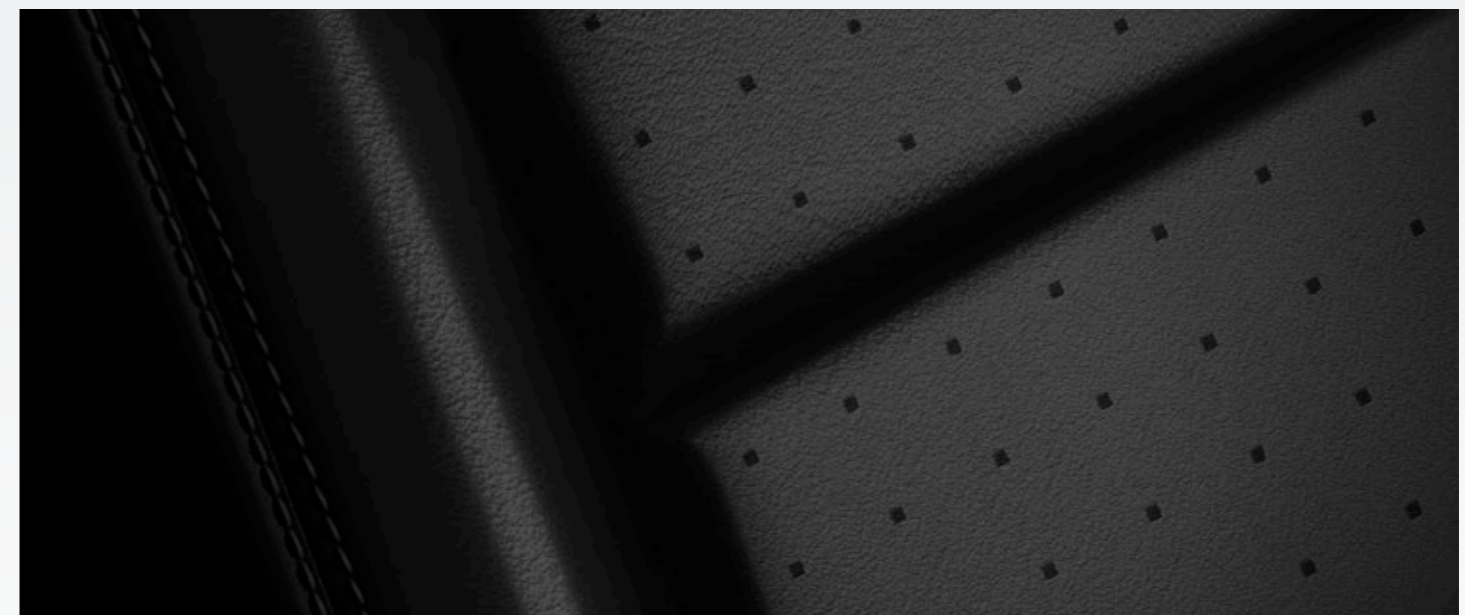

Get comfortable

Inviting leather seats feature 8-way power adjustment for maximum driver comfort. This is available on the SLE model only.



Body colours



Cool White



Aluminium Metallic

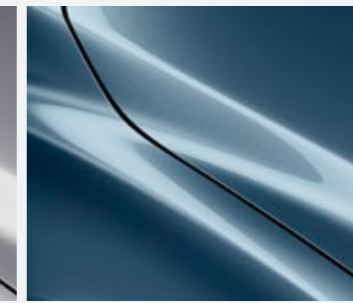

Blue Reflex Mica

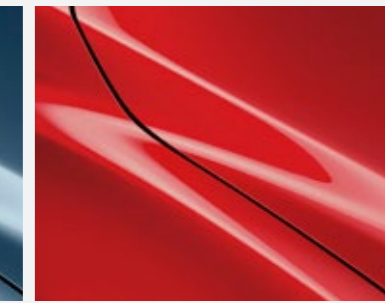

True Red



Titanium Flash Mica

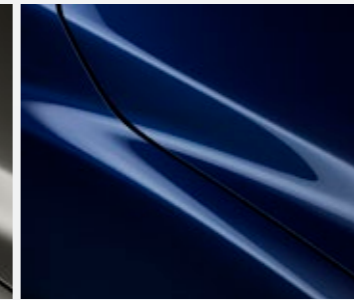

Deep Crystal Blue Mica



Jet Black Mica

■ 3-Year ***MAZDA*** Unlimited Kilometre Warranty

Every Mazda is designed and built to the highest standards of performance and reliability. To give you further reassurance on how much we believe in our vehicles, our Mazda vehicles are backed up by a 3-year, Unlimited Kilometre Factory Warranty.

■ 3-Year ***MAZDACARE*** Unlimited Roadside Assistance

Mazda cares about offering you peace-of-mind motoring. That is why we offer a 3-year Unlimited Roadside Assistance Plan to keep you moving every minute of the year. It includes toll-free calls and services such as free towing rescue due to minor or major mishaps and emergency medical help.

■ 3-Year ***MAZDACARE*** Unlimited Kilometre Service Plan

MazdaCare has designed a Service Plan to suit your needs. It covers scheduled services for 3 years, regardless of your mileage. The service plan operates alongside the Mazda Unlimited Kilometre Warranty.

SPECIFICATIONS

Double cab					
	BT-50 DBL 2.2L 6MT 4X2 SLX	BT-50 DBL 2.2L 6MT 4X2 SLE	BT-50 DBL 2.2L 6AT 4X2 SLE	BT-50 DBL 3.2L 6MT 4X4 SLE	BT-50 DBL 3.2L 6AT 4X4 SLE
Engine					
Type	In-line 4-cylinder, DOHC, 16-valve, turbo, intercooled	In-line 4-cylinder, DOHC, 16-valve, turbo, intercooled	In-line 4-cylinder, DOHC, 16-valve, turbo, intercooled	In-line 5-cylinder, DOHC, 20-valve, turbo, intercooled	In-line 5-cylinder, DOHC, 20-valve, turbo, intercooled
Displacement	2198	2198	2198	3198	3198
Bore & stroke (mm)	86.0 X 94.6	86.0 X 94.6	86.0 X 94.6	89.9 X 100.7	89.9 X 100.7
Compression ratio	15.5:1	15.5:1	15.5:1	15.5:1	15.5:1
Fuel injection	Common-rail electronic direct-injection	Common-rail electronic direct-injection	Common-rail electronic direct-injection	Common-rail electronic direct-injection	Common-rail electronic direct-injection
Power (kW @ rpm)	110 @ 3700	110 @ 3700	110 @ 3700	147 @ 3000	147 @ 3000
Torque (Nm @ rpm)	375 @ 1500-2500	375 @ 1500-2500	375 @ 1500-2500	470 @ 1750-2500	470 @ 1750-2500
Turbocharger type	Variable-nozzle	Variable-nozzle	Variable-nozzle	Variable-nozzle	Variable-nozzle
Fuel consumption (100/L)	7,6	7,6	9,4	9,3	9,7
Co ₂ emission (g/km)	199	199	248	245	256
Top speed km/h (with limiter)	175	175	175	175	175
Transmission					
Type	6-Speed manual	6-Speed manual	6-Speed automatic	6-Speed manual	6-Speed automatic
Rear differential	Locking	Locking	Locking	Locking	Locking
4X4 electronic shift on the fly	-	-	-	Std	Std
1st gear ratio	5,441	5,441	4,171	5,441	4,171
2nd gear ratio	2,839	2,839	2,342	2,839	2,342
3rd gear ratio	1,721	1,721	1,521	1,721	1,521
4th gear ratio	1,223	1,223	1,143	1,223	1,143
5th gear ratio	1,000	1,000	0,867	1,000	0,867
6th gear ratio	0,794	0,794	0,691	0,794	0,691
Reverse gear	4,935	4,935	3,403	4,935	3,403
Final gear ratio	3,31	3,31	3,73	3,55	3,73
Transfer gear: high	-	-	-	1,000	1,000
Transfer gear: low	-	-	-	2,717	2,717
Steering					
Rack & pinion	Std	Std	Std	Std	Std
Power assisted (engine-rev sensing)	Std	Std	Std	Std	Std
Steering column tilt adjust	Std	Std	Std	Std	Std
3-Spoke polyurethane steering wheel	Std	-	-	-	-
3-Spoke leather wrapped steering wheel	-	Std	Std	Std	Std
Cruise control/steering wheel mounted audio controls	Std	Std	Std	Std	Std
Brakes					
4 Wheel ABS and EBD	Std	Std	Std	Std	Std
Electronic stability program (ESP)	Std	Std	Std	Std	Std
Front: ventilated disc	Std	Std	Std	Std	Std
Rear: drums	Std	Std	Std	Std	Std
Wheels and tyres					
Tyre size	255/70R16	265/65R17	265/65R17	265/65R17	265/65R17
Spare wheel	16X7" steel	17X8" steel	17X8" steel	17X8" steel	17X8" steel
Type	Alloy	Alloy	Alloy	Alloy	Alloy
Wheel size	16X7"	17X8"	17X8"	17X8"	17X8"
Exterior					
Body colour plastic front bumper	Std	Std	Std	Std	Std
Steel step chrome rear bumper	Std	Std	Std	Std	Std
Radiator grille painted gun metal	Std	Std	Std	Std	Std
Exterior door handle, tailgate handle & mirror scalp	As molded black	Chrome	Chrome	Chrome	Chrome
Extruded aluminum side steps with plastic end caps	Std	Std	Std	Std	Std
Front & rear mud flaps	Std	Std	Std	Std	Std
Sliding rear window	Solid	Solid	Solid	Solid	Solid
Headlamp	Halogen	Halogen	Halogen	Halogen	Halogen
Auto on/off headlamps	-	Std	Std	Std	Std
Front fog lamps	Std	Std	Std	Std	Std
Roof mounted high mounted stop lamp	Std	Std	Std	Std	Std
Turning indicators	In mirrors	In mirrors	In mirrors	In mirrors	In mirrors
Load box inner tie downs	Std	Std	Std	Std	Std
Interior comfort and convenience					
Exterior mirrors	Power adjust/power fold	Power adjust/power fold	Power adjust/power fold	Power adjust/power fold	Power adjust/power fold
Front wipers	Intermittent variable speed	Rain sensing	Rain sensing	Rain sensing	Rain sensing
Power windows (with driver one-touch up & down)	Std	Std	Std	Std	Std
Single-zone manual air conditioner	Std	-	-	-	-
Dual-zone fully automatic air conditioner	-	Std	Std	Std	Std
AM/FM radio /MP3 CD – integrated audio module	Std	Std	Std	Std	Std
Multi-function display	Dot matrix	Dot matrix	Dot matrix	Dot matrix	Dot matrix
Audio integrated control panel	Low	High	High	High	High
AUX & USB/iPod	Aux & usb/ipod	Aux & usb/ipod	Aux & usb/ipod	Aux & usb/ipod	Aux & usb/ipod
Bluetooth voice control	Std	Std	Std	Std	Std
Speakers	4 Speakers	4 Speakers + 2 tweeters	4 Speakers + 2 tweeters	4 Speakers + 2 tweeters	4 Speakers + 2 tweeters
Cruise control	Std	Std	Std	Std	Std
Ashtray with cigar lighter (acts as power point)	Std	Std	Std	Std	Std
2nd power point AUX in IP	Std	Std	Std	Std	Std
3rd power point (rear of console)	Std	Std	Std	Std	Std
Gear knob material	Plastic	Leather	Leather	Leather	Leather
Long center console - double lid with 2 cup holders & with coin storage	Std - plastic lid	Std - plastic lid	Std - plastic lid	Std - plastic lid	Std - plastic lid

Driver sun visor/passenger sun visor with vanity mirror	Std	Std	Std	Std	Std
Driver's roof mounted grab handle	Std	Std	Std	Std	Std
Passenger side A pillar assist handle	Std	Std	Std	Std	Std
Door trim material insert	Cloth	Leather	Leather	Leather	Leather
Back panel trim	Non-woven premium	Non-woven premium	Non-woven premium	Non-woven premium	Non-woven premium
Interior release/door handle	As molded black	As molded black	As molded black	As molded black	As molded black
Centre panel/stack bezel	Painted - accented colour	Painted - accented colour	Painted - accented colour	Painted - accented colour	Painted - accented colour
Parking brake button	As molded black	As molded black	As molded black	As molded black	As molded black
Floor coverings	Non-woven premium	Non-woven premium	Non-woven premium	Non-woven premium	Non-woven premium
Front seat	Bucket seats	Bucket seats	Bucket seats	Bucket seats	Bucket seats
Driver seat adjustment – manual	4 Way with lumbar support	-	-	-	-
Driver seat adjustment – electric	-	8 Way with lumbar support	8 Way with lumbar support	8 Way with lumbar support	8 Way with lumbar support
Passenger seat adjustment - manual	2 Way	2 Way	2 Way	2 Way	2 Way
Passenger seat map pocket	Std	Std	Std	Std	Std
Rear seats with fold-up cushion & partial fold forward back cushion	Std	Std	Std	Std	Std
Centre armrest with cup holder	Std	Std	Std	Std	Std
Rear head restraints (2 outboard head restraints with center head restraint)	Std	Std	Std	Std	Std
Seat fabric	Cloth	Leather	Leather	Leather	Leather
Dome interior light with theatre dimming & illuminated entry	Std	Std	Std	Std	Std
Overhead console with map lights	Std	Std with sunglasses holder	Std with sunglasses holder	Std with sunglasses holder	Std with sunglasses holder
Lockable glove box & glove box lighting	Std	Std	Std	Std	Std
External temperature display	Std	Std	Std	Std	Std
Trip computer (trip A/trip B/fuel consumption/average fuel consumption/average speed/distance to empty)	Std	Std	Std	Std	Std
Safety and security					
Central locking/unlocking & drive-away locking	Std	Std	Std	Std	Std
Remote keyless entry with 2-stage unlocking and flip key	Std	Std	Std	Std	Std
Second remote ignition flip key	Std	Std	Std	Std	Std
Child proof door locks	Std	Std	Std	Std	Std
Height adjustable front seat belts	Std	Std	Std	Std	Std
Rear seat belts - two outboard 3-point + one centre 2-point	Std	Std	Std	Std	Std
Driver & front passenger airbag, seat side airbag & side curtain airbag	Std	Std	Std	Std	Std
Belt minder - buckle switch warning & driver's seat belt led warning	Driver & passenger	Driver & passenger	Driver & passenger	Driver & passenger	Driver & passenger
Rear parking assist	-	Rear view camera (in rear view mirror)	Rear view camera (in rear view mirror)	Rear view camera (in rear view mirror)	Rear view camera (in rear view mirror)
Volumetric burglar alarm system	Std	Std	Std	Std	Std
Emergency brake assist (EBA)	Std	Std	Std	Std	Std
Brake override system (BOS)	Std	Std	Std	Std	Std
Load adaptive control (LAC)	-	-	-	Std	Std
Trailer sway mitigation (TSM)	-	-	-	Std	Std
Roll over mitigation (ROM)	-	-	-	Std	Std
Hill launch assist (HLA)	-	-	-	Std	Std
Hill descent control (HDC) [4WD only]	-	-	-	Std	Std
Dimensions & capacities					
Fuel tank (litres)	80L	80L	80L	80L	80L
Minimum ground clearance – unladen (mm)	237	237	237	237	237
Overall height (mm)	1815	1821	1821	1821	1821
Overall length (mm)	5365	5365	5365	5365	5365
Overall width (mm) [w/o outer mirror]	1850	1850	1850	1850	1850
Wheelbase (mm)	3220	3220	3220	3220	3220
Load box height (mm)	513	513	513	513	513
Load box floor length (mm)	1549	1549	1549	1549	1549
Load box width (mm)	1560	1560	1560	1560	1560
Water wading (mm)	800	800	800	800	800
Towing capacity braked (kg)	1800	1800	3500	3500	3500
Tare mass (kg)	1963	1963	1963	1963	1963
Gross vehicle mass [GVM] (kg)	3200	3200	3200	3200	3200
Gross combination mass [GCM] (mm)	5000	5000	5950	5950	5950
Gross axle mass – front (kg)	1350	1350	1350	1350	1350
Gross axle mass/axle-unit mass – rear (kg)	1850	1850	1850	1850	1850
Vehicle capacity					
Dual front towing hooks	Std	Std	Std	Std	Std
Tow bar	Heavy duty	Heavy duty	Heavy duty	Heavy duty	Heavy duty
Heavy duty battery	-	-	-	Std	Std
Suspension & body					
High-trail	Std	Std	Std	Std	Std
Front: Independent, double-wishbone with coil springs	Std	Std	Std	Std	Std
Rear: rigid axle with leaf springs	Std	Std	Std	Std	Std
Engine underbody protection	-	-	-	Std	Std
Fuel tank guard	-	-	-	Std	Std
Engine cover	Std	Std	Std	Std	Std
Warranty & service					
Service intervals	15000km	15000km	15000km	15000km	15000km
Service & warranty plan	3 Year/Unlimited km	3 Year/Unlimited km	3 Year/Unlimited km	3 Year/Unlimited km	3 Year/Unlimited km
Mazda roadside assistance	3 Year/Unlimited km	3 Year/Unlimited km	3 Year/Unlimited km	3 Year/Unlimited km	3 Year/Unlimited km







mazda

zoom-zoom



3
YEAR
UNLIMITED KM
WARRANTY &
SERVICE PLAN

MAZDA BT-50

mazda.co.za     | The impossible made possible.