



THE ALL-NEW
VOLVO XC90







WE'RE VOLVO CARS

We put people first.

We're Swedish. Scandinavian designers always start with the person who's going to use an object and ask, "What can we do to make this person's life better, easier or more comfortable?" We've always used this philosophy when we design our cars. So, while other car manufacturers might start with technology and try to squeeze people in around it, we begin by designing our cars around you. We ask what you need, and then use our technical skills to make your life easier, better, safer and more beautiful. Form follows function, and when you design a car inside and out with people in mind, it looks naturally beautiful. We think that looking at and interacting with our cars should make you feel great, every day. Designing cars around people has led to many innovations over our 88-year history.

You know the three-point safety belt in your current car? That was our invention from 1959. And now we're working towards our vision to design cars that should not crash. In the shorter perspective, our aim is that by 2020 nobody should be killed or seriously injured in a new Volvo. Of course, you'll already benefit from this research in your current Volvo. We've addressed a few environmental issues, too – in 1976, we developed the Lambda Sond – a sensor that monitors exhaust gas, reducing emissions and boosting performance as well as economy. It's still part of every petrol-engined car in the world. Innovation is at the core of Volvo Cars.

"As with any luxury item – a finely crafted watch, a bespoke suit – its beauty might be obvious, but its true value is only revealed when you discover the expertise, the craftsmanship and the passion that went into making it."

ROAD PRESENCE

Be impressed, quite simply.

You know you're looking at truly great design when what appears simple at first glance turns out to be ingenious and stimulating once you discover the thoughts and details that make up the whole. And as with any luxury item – a finely crafted watch, a bespoke suit – its beauty might be obvious, but its true value is only revealed when you discover the expertise, the craftsmanship and the passion that went into making it.

The all-new Volvo XC90 has this quality. Appropriately for a full-sized SUV, it exudes power, particularly with the upright grille and the strong shoulders, both of which

are classic Volvo style cues. As exterior designer Anders Gunnarsson says, "The car has an attitude that expresses confidence and self-belief. If you're proud and relaxed about your position in the world, you'll stand upright – just like the Volvo XC90."

But despite this sense of presence, the design is also exquisitely subtle: "It grows on you," says Thomas Ingenlath, Volvo Car's Senior Vice President of Design. "It's not all spectacle – it's about leaving the proportions and the technology underneath to create the drama. You suddenly realise how much sheet metal movement there is in the side section – how it grows over the rear wheel.

It's about perfect execution, and that took such a long time to achieve."

"The task to design the rear was more difficult", says Ingenlath. "We didn't want to use the elements that everyone else is using to make a car look more powerful. Most other car manufacturers are using horizontal lines. We used vertical lines. That is something that can be difficult. If you are good at it, you give a car an incredible status. We achieved that kind of status by reduction – not going into the horizontal but staying proud and upright. That is a nice aspect."



The choice is yours.

Choosing the all-new Volvo XC90 was the easy part. Now all you have to do is give it the twist that best matches your personality. Momentum is our most accessible variant.

And if you're aiming for top-of-the range luxury, you'll love Inscription with its distinctive grille. Finally, the R-Design is all about a sporty look, both inside and out.



XC90 MOMENTUM

This is a luxury car by any measure, and one that promises more than rewarding comfort and class-leading style. This is a luxury car that's smarter and stronger in all the right places, for all the right reasons: you.

D4 FWD
D5 AWD

T5 AWD
T6 AWD
T8 Twin Engine



XC90 INSCRIPTION

Exquisite details

Our exclusive Inscription version adds a more luxurious look and feel to the all-new XC90. Each unique detail was carefully chosen for the driver who wants a bit more elegance, like the interior's soft Nappa leather and a stand-out front grille.

**D4 FWD
D5 AWD**

**T5 AWD
T6 AWD
T8 Twin Engine**



XC90 R-DESIGN

A sporty presence

This version was made for those who love to drive. With a unique, expressive personality distinguished by the R-Design grille, sport Contour seats, and matte silver mirror covers.

D5 AWD

**T5 AWD
T6 AWD
T8 Twin Engine**

THE RIGHT EQUIPMENT. It's essential that your Volvo comes equipped with everything you need. Below you'll find the standard equipment lists for each model variant, plus optional equipment to personalise your all-new Volvo XC90. And as you'd expect, there is an array of industry-leading, cutting edge safety innovations.

STANDARD EQUIPMENT - SAFETY AND SECURITY	XC90 D4 FWD	XC90 D5 AWD	XC90 T5 AWD	XC90 T6 AWD	XC90 T8 TWIN ENGINE
City Safety (includes Pedestrian & Cyclist Detection and Front Collision Warning with Full Auto Brake)	•	•	•	•	•
Driver Alert Control with Lane Departure Warning (LDW)	•	•	•	•	•
Road Sign Information Display (RSI)	•	•	•	•	•
Dual Stage Driver and Passenger Airbags	•	•	•	•	•
Passenger Airbag Cut-off Switch	•	•	•	•	•
SIPS (Side Impact Protection System)	•	•	•	•	•
SIPS Airbags (Front Seats)	•	•	•	•	•
Inflatable Curtains - Full Length	•	•	•	•	•
Whiplash Protection System (Front Seats)	•	•	•	•	•
Vehicle Deceleration Control (includes Anti-lock Brake System, Electronic Brake Distribution & Emergency Brake Assist)	•	•	•	•	•
Stability and Traction Control (includes Spin Control, Engine Drag Control and Corner Traction Control)	•	•	•	•	•
ISOFIX Attachments (2nd Row Outer Seats)	•	•	•	•	•
Hill start assist	•	•	•	•	•
Hill descent control	•	•	•	•	•
Anti-theft Alarm including Immobiliser, Volume Sensor and Level Sensor	•	•	•	•	•
Integrated Remote Control Central Locking and Auto Open/Close Power Windows and Sunroof	•	•	•	•	•
Key remote control	•	•	•	•	•
Two step door unlocking	•	•	•	•	•
Private Locking for Glove box and Tailgate	•	•	•	•	•
Power child locks (Rear Doors)	•	•	•	•	•
Central lock switch with diode in front doors	•	•	•	•	•
Visible VIN Plate	•	•	•	•	•
Automatic Headlight Levelling System	•	•	•	•	•
Home Safe and Approach Lighting	•	•	•	•	•
LED Daytime Running Lights	•	•	•	•	•
Auto dimming Interior and Exterior Mirrors	•	•	•	•	•
Grocery bag holder	•	•	•	•	•
Warning Triangle	•	•	•	•	•









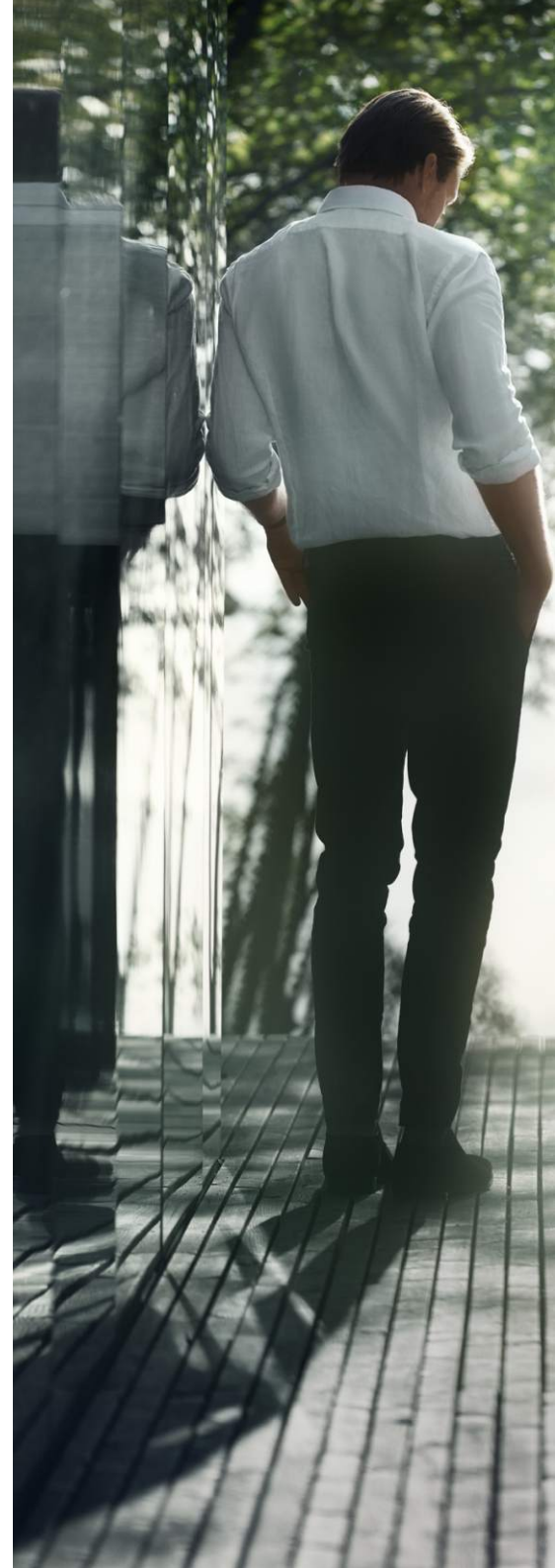

STANDARD EQUIPMENT - EXTERIOR	XC90 D4 FWD	XC90 D5 AWD	XC90 T5 AWD	XC90 T6 AWD	XC90 T8 TWIN ENGINE
Bright integrated roof rails (standard on Inscription & R-Design)	•	•	•	•	•
Silver roof rails on black foot (standard on Momentum)	•	•	•	•	•
Front grill Piano black (standard on Momentum)	•	•	•	•	•
Inscription front grill	•	•	•	•	•
Bright décor around side windows	•	•	•	•	•
Laminated side windows	•	•	•	•	•
Fully colour adapted sills and bumpers (standard on Momentum & R-Design)	•	•	•	•	•
Fully colour adapted sills and bumpers with bright side décor branded - Inscription	•	•	•	•	•
Colour coordinated door handles with bright décor	•	•	•	•	•
Inscription bright trim level element exterior rear	•	•	•	•	•
Painted wheel arches (19" wheels and smaller) standard on Momentum	•	•	•	•	•
Painted wheel arches (20" wheels and larger) standard on Inscription & R-Design	•	•	•	•	•
Dual visible tail pipes with chrome sleeves (Momentum only)	•	•	•	•	
Dual integrated tail pipes (standard on Inscription, R-Design & T8 Twin Engine)	•	•	•	•	•
Colour coordinated rearview mirror covers	•	•	•	•	•
Retractable side mirrors	•	•	•	•	•
LED Active Bending Headlights with Active High Beam	•	•	•	•	•
Headlight Cleaning System	•	•	•	•	•
Front LED Fog lights inclusive of Cornering lights	•	•	•	•	•
Adaptive Brake Lights including High Level LED Brake Light	•	•	•	•	•
Power Operated Tailgate with Handsfree Opening	•	•	•	•	•
Panoramic sunroof					•
19" 6-Spoke Turbine Silver Alloy Wheels - 235/55R19 (standard on T8 Momentum)					•
19" 10-Spoke Turbine Silver Alloy Wheels (standard on Momentum)	•	•	•	•	
20" 10-Spoke Silver Diamond Cut Alloy Wheels (standard on Inscription)	•	•	•	•	•
20" 5-Spoke Matt Black Diamond Cut Alloy Wheels (R-Design)		•	•	•	•
Tempa Spare Wheel and Jack kit (n/a on T8 Twin Engine)	•	•	•	•	
Tyre repair kit (standard on T8 Twin Engine)					•
RDESIGN High Gloss Black Mesh Front Grille with Silk Metal Surround		•	•	•	•
RDESIGN Silk metal décor around side windows		•	•	•	•
RDESIGN colour coordinated door handles		•	•	•	•
RDESIGN Glossy black stripe on rear bumper		•	•	•	•
RDESIGN Matt Silver rearview mirror covers		•	•	•	•

STANDARD EQUIPMENT - INTERIOR	XC90 D4 FWD	XC90 D5 AWD	XC90 T5 AWD	XC90 T6 AWD	XC90 T8 TWIN ENGINE
Leather Upholstery (Momentum)	•	•	•	•	•
Nappa Soft Leather comfort seats (Inscription)	•	•	•	•	•
Suede / Nappa Sport leather upholstery (R-Design)		•	•	•	•
12,3 inch Instrument cluster	•	•	•	•	•
Cruise control	•	•	•	•	•
Power Driver Seat with Electric Lumbar Support and Memory for Seat & Exterior Mirrors	•	•	•	•	•
Power Passenger Seat with Power Height Adjustment, Memory function and Electric Lumbar Support	•	•	•	•	•
Three 2nd Row Individual Folding Seats (40/20/40 Split)	•	•	•	•	•
Two 3rd Row Individual Folding Seats	•	•	•	•	•
Front and 2nd Row Armrest with Storage and Cup holders	•	•	•	•	•
Manually foldable rear headrests	•	•	•	•	•
Outboard Armrests with Cup holders and Storage for Third Row seats	•	•	•	•	•
Cross Brushed Aluminium Inlays (Momentum)	•	•	•	•	•
Metal Mesh décor inlays (Inscription & R-Design)	•	•	•	•	•
Blond headlining (not applicable on R-Design)	•	•	•	•	•
Interior illumination - Mid level (Momentum)	•	•	•	•	•
Interior illumination - High level (Inscription & R-Design)	•	•	•	•	•
Illuminated vanity mirrors in sunvisor LH / RH side	•	•	•	•	•
3-Spoke leather steering wheel with deco inlay	•	•	•	•	•
Orrefors Crystal Gear Lever Knob (T8 Twin Engine only)					•
Leather gear lever knob	•	•	•	•	•
Standard Pedals	•	•	•	•	•
Cigarette lighter / Ashtray front + Ashtray in rear doors	•	•	•	•	•
Automatically dimmed inner and exterior mirrors	•	•	•	•	•
Carpet kit (Momentum)	•	•	•	•	•
Carpet kit (Inscription)	•	•	•	•	•
Carpet kit, row 3	•	•	•	•	•
Sill moulding Volvo metal (Momentum only)	•	•	•	•	•
Sill moulding Volvo metal illuminated (standard on Inscription)	•	•	•	•	•
Park Assist Pilot + Park Assist Front and Rear	•	•	•	•	•
Drive modes & power steering settings		•	•	•	•
4-Zone Electronic Climate Control with 'CleanZone' Air Quality System and Pollen Filter	•	•	•	•	•
Lockable Glove box Compartment with Illumination	•	•	•	•	•
Climate control unit, 3rd row	•	•	•	•	•
Humidity sensor	•	•	•	•	•
Rain sensor	•	•	•	•	•
B-Pillar Ventilation	•	•	•	•	•
Pre-ventilation + prolonged heating after engine shut off (T8 Twin Engine only)					•
High voltage coolant heater (T8 Twin Engine only)					•
Front and Rear Power Windows	•	•	•	•	•
Semi-Automatic Load Cover	•	•	•	•	•
Luggage Compartment Illumination	•	•	•	•	•
Soft load net stored in bag	•	•	•	•	•
Cargo opening scuff plate - metal	•	•	•	•	•
Cargo divider / Storage tray (under load floor)	•	•	•	•	•



STANDARD EQUIPMENT - INTERIOR Continued	XC90 D4 FWD	XC90 D5 AWD	XC90 T5 AWD	XC90 T6 AWD	XC90 T8 TWIN ENGINE
12v Socket (Front and Rear Tunnel Console and luggage area)	•	•	•	•	•
Windscreen washer nozzles - not heated	•	•	•	•	•
High performance audio system (1 AUX and 1 USB)	•	•	•	•	•
Remote control buttons on steering wheel	•	•	•	•	•
Navigation - Pro (Map region for Africa)	•	•	•	•	•
 R-Design steering wheel with perforated leather, 3-spoke		•	•	•	•
 Gearshift paddles (R-Design only)		•	•	•	•
 R-Design perforated leather gear knob		•	•	•	•
 R-Design pedals		•	•	•	•
 R-Design carpet kit		•	•	•	•
 R-Design illuminated sill moulding		•	•	•	•
 R-Design key remote control, leather clad		•	•	•	•

* OPTIONAL EQUIPMENT - SAFETY AND SECURITY	Price incl. 14% VAT	XC90 D4 FWD	XC90 D5 AWD	XC90 T5 AWD	XC90 T6 AWD	XC90 T8 TWIN ENGINE
Keyless Drive (includes Keyless Entry and Keyless Start) with Remote Tag	R7,200.00	o	o	o	o	o
Adaptive Cruise Control (ACC) including lane keeping aid	R19,000.00	o	o	o	o	o
Head-Up display - Graphical	R13,800.00	o	o	o	o	o
Blind spot Information System with Cross traffic alert (BLIS & CTA) Collision Warning and Mitigation support, rear	R8,100.00	o	o	o	o	o
Park Assist Camera	R9,300.00	o	o	o	o	o
Visual Park Assist + Front "Fisheye" view (360 degree camera)	R11,600.00	o	o	o	o	o

* OPTIONAL EQUIPMENT - INTERIOR	Price incl. 14% VAT	XC90 D4 FWD	XC90 D5 AWD	XC90 T5 AWD	XC90 T6 AWD	XC90 T8 TWIN ENGINE
Nappa Soft Leather - Comfort seats (Momentum)	R10,500.00	o	o	o	o	o
Nappa Soft Leather - Sport Contour seats (Momentum)	R17,500.00	o	o	o	o	o
Nappa Soft Leather - Sport Contour seats (Inscription)	R7,000.00	o	o	o	o	o
Nappa Soft Leather - Perforated & Ventilated Comfort seats (Momentum)	R21,500.00	o	o	o	o	o
Nappa Soft Leather Perforated & Ventilated Comfort seats (Inscription)	R11,000.00	o	o	o	o	o
Nappa Soft Leather - Perforated & Ventilated Sport seats (R-Design only)	R13,500.00	n/a	o	o	o	o
Linear Walnut décor inlays (not available on R-Design)	R2,850.00	o	o	o	o	o
3-Spoke Leather Steering Wheel with wood décor (not available on R-Design)	R2,500.00	o	o	o	o	o
Dark Flame birchwood décor inlays (not available on R-Design)	R2,850.00	o	o	o	o	o
R-Design Carbon Fibre décor inlays	R2,850.00	n/a	o	o	o	o
Sun blinds, rear side door windows	R2,850.00	o	o	o	o	o
Leather upgrade on dashboard + front / rear doors (Only with Nappa leather)	R15,500.00	o	o	o	o	o
Black headlining (standard on R-Design)	R3,000.00	o	o	o	o	o
Heated windscreen washer nozzles	R750.00	o	o	o	o	o
Heated steering wheel	R2,500.00	o	o	o	o	o
Heated windscreen	R3,650.00	o	o	o	o	o
Heated front seats	R3,500.00	o	o	o	o	o
Heated rear seats	R2,850.00	o	o	o	o	o

* OPTIONAL EQUIPMENT - INTERIOR Continued	Price incl. 14% VAT	XC90 D4 FWD	XC90 D5 AWD	XC90 T5 AWD	XC90 T6 AWD	XC90 T8 TWIN ENGINE
Driver and Passenger Seat Power Cushion Extension (Not on R-Design)	R2,500.00	o	o	o	o	o
Backrest massage, front seats (Not on R-Design)	R5,500.00	o	o	o	o	o
Power folding rear headrests	R1,950.00	o	o	o	o	o
Child seat - centre rear seat	R2,500.00	o	o	o	o	o
Power operated backrest 3rd row	R6,250.00	o	o	o	o	o
230V / 150W outlet in lower rear tunnel (n/a on T8 Twin Engine)	R1,200.00	o	o	o	o	n/a
Black carpet kit (for light interiors)	no cost	o	o	o	o	o
Interior illumination - High level (Momentum)	R2,250.00	o	o	o	o	o
Compass in rearview mirror	R1,250.00	o	o	o	o	o
Premium Sound by Bowers and Wilkins	R36,500.00	o	o	o	o	o
CD player in centre console storage (n/a on T8 Twin Engine)	R1,750.00	o	o	o	o	n/a
USB Hub	R1,300.00	o	o	o	o	o
Subwoofer	R3,850.00	o	o	o	o	o
Drive mode settings (D4 FWD only)	R1,250.00	o	●	●	●	●
Apple CarPlay	R1,500.00	o	o	o	o	o
Charge cord bag (T8 Twin Engine)	R350.00	n/a	n/a	n/a	n/a	o

* OPTIONAL EQUIPMENT - EXTERIOR	Price incl. 14% VAT	XC90 D4 FWD	XC90 D5 AWD	XC90 T5 AWD	XC90 T6 AWD	XC90 T8 TWIN ENGINE
Panoramic sunroof (standard on T8 Twin Engine)	R16,600.00	o	o	o	o	●
Tinted windows, rear side doors and cargo area	R4,700.00	o	o	o	o	o
18" 6-Double Spoke Sparkling Silver Alloy Wheel – 235/60R18 (Only on Momentum)	no cost	o	o	o	o	n/a
18" 5-Spoke Sparkling Silver Alloy Wheel – 235/60R18 (Only on Momentum)	no cost	o	o	o	o	n/a
19" 6-spoke Turbine silver alloy wheel – 235/55R19 (Standard on T8 Momentum)	no cost	o	o	o	o	●
19" 10-spoke Turbine silver alloy wheel – 235/55R19 (Inscription)	no cost	o	o	o	o	n/a
20" 5-Double Spoke Matt Tech Black Diamond Cut Alloy Wheel – 275/45R20 (Not on T8 & R-Design)	R8,500.00	o	o	o	o	n/a
21" 8-Spoke Diamond Cut / Silver Alloy wheel - 275/40R21 (Only on Inscription)	R12,500.00	o	o	o	o	o
22" 5-Double Spoke Matt Black Diamond Cut Alloy Wheel - 275/35R22 (Only on R-Design)	R19,500.00	n/a	o	o	o	o
Air suspension, 4-corner & Four-C chassis	R26,500.00	o	o	o	o	o
Metallic Paint	R3,250.00	o	o	o	o	o
Exterior illumination preparation	R750.00	o	o	o	o	o

● = standard; o = option; n/a = not available * Fitted at factory









	XC90 D4 FWD	XC90 D5 AWD	XC90 T5 AWD	XC90 T6 AWD	XC90 T8 TWIN ENGINE
Prices are inclusive of 14% VAT					
TECHNO PACK	R 40,000.00	R 40,000.00	R 40,000.00	R 40,000.00	R 40,000.00
Heated Front Seats	o	o	o	o	o
Head Up Display - HUD (graphical)	o	o	o	o	o
Adaptive Cruise Control (ACC) & Lane keeping aid (LKA)	o	o	o	o	o
Blind spot Information System with Cross traffic alert (BLIS & CTA)	o	o	o	o	o
Park Assist Camera	o	o	o	o	o
Keyless entry with remote tag and handsfree tailgate opening	o	o	o	o	o
PREMIUM PACK	R 55,000.00	R 55,000.00	R 55,000.00	R 55,000.00	R 55,000.00
Heated Front Seats	o	o	o	o	o
Head Up Display - HUD (graphical)	o	o	o	o	o
Visual Park Assist + Front "Fisheye" view (360 degree camera)	o	o	o	o	o
Power adjustable side support	o	o	o	o	o
Premium Sound audio by Bowers and Wilkins	o	o	o	o	o
Blind spot Information System with Cross traffic alert (BLIS & CTA)	o	o	o	o	o
Keyless entry with remote tag and handsfree tailgate opening	o	o	o	o	o
REDESIGN PACK	n/a	R 53,500.00	R 53,500.00	R 53,500.00	R 53,500.00
Heated Front Seats		o	o	o	o
Head Up Display - HUD (graphical)		o	o	o	o
Visual Park Assist + Front "Fisheye" view (360 degree camera)		o	o	o	o
Premium Sound audio by Bowers and Wilkins		o	o	o	o
Blind spot Information System with Cross traffic alert (BLIS & CTA)		o	o	o	o
Keyless entry with remote tag and handsfree tailgate opening		o	o	o	o

o = option; n/a = not available

VOLVO SENSUS. THE BEAUTY OF INFORMATION.

SENSUS

YOUR SPACE

Nothing rounds off a drive in your car better than luxuriating in the rich sound of your favourite piece of music. And our two sound systems – Premium Sound by Bowers & Wilkins* and High Performance Sound – turn any drive into a momentous experience.

Thanks to Sensus Connect, which is standard, you can stream your favourite tunes from your device to your car via Bluetooth®. You can also use Bluetooth® or WiFi tethering to connect your XC90 to the internet via your device. You can then browse the web and access a variety of internet radio and media apps.

With Sensus Navigation, you can view your route on the centre display with touch screen functionality. And with Apple CarPlay, you can use the centre display to access your iPhone® as well (version 5 or later). And if you'd like to connect devices physically, AUX- and USB-ports are provided as well.

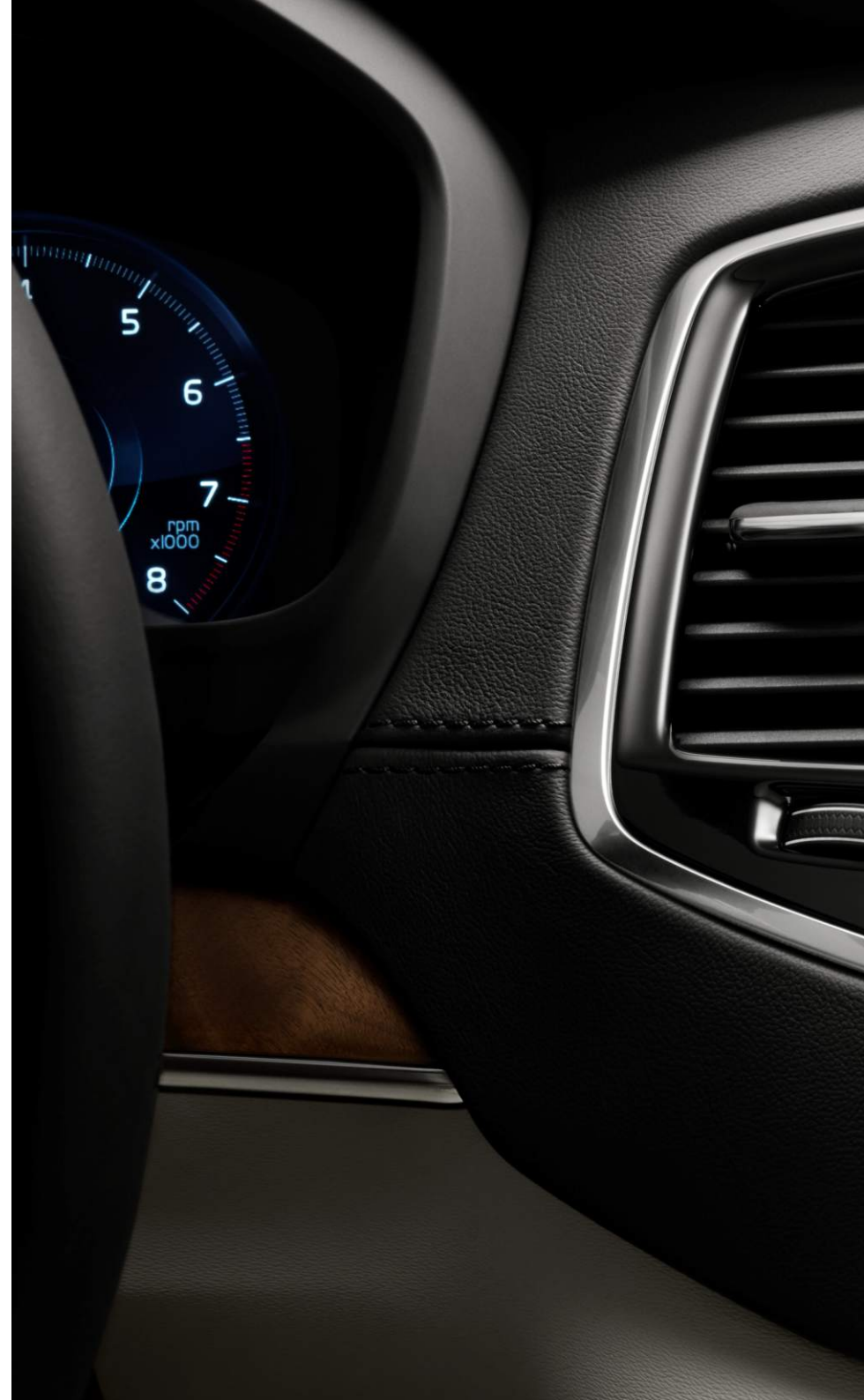

Navigation Bråland 522
Next exit: 90-Stora Högamotet

Media - Bluetooth

Arizona Rain/ Color Me
The Skies Belong To Us
1:02 3:55

Color Me

Wave Goodbye
Arizona Rain / Color Me

Arizona Rain
Arizona Rain / Color Me

Color Me
Arizona Rain / Color Me

The Skies Belong to Us
Arizona Rain / Color Me

Nights
Arizona Rain / Color Me

Library

Shuffle

Recent

CD

FM-Radio

AUX

Phone Telenor
Daniel's Phone

22°C

AUTO

22°C

WE PROTECT WHAT'S MOST IMPORTANT. YOU AND YOUR FAMILY.

INTELLISAFE

WE CARE ABOUT YOU

The XC90 is packed with intuitive safety technologies as standard. They support you in your daily driving, help you avoid or mitigate collisions and protect you in the event of an accident. Most of the time, you won't be aware of these helpers, but they're watching out for you, day or night. We call this comprehensive, innovative approach to your safety IntelliSafe.

This commitment goes back to 1927. Our founders, Assar Gabrielsson and Gustaf Larson, stated that "cars are driven by people, so the guiding principle behind everything we make at Volvo is, and must remain, safety." Eighty-eight years on, our vision is to design cars that should not crash. In the shorter perspective, the aim is that by 2020 no-one should be killed or seriously injured in a new Volvo. We think our founders would have approved.

The all-new Volvo XC90 is yet another step towards this ambition. In 2008, we launched City Safety – the world's first collision avoidance technology. In the all-new Volvo XC90, City Safety has become more capable and versatile than ever. Day and night, it can

help avoid or mitigate collisions with other cars, pedestrians and cyclists in your path. And now, City Safety also includes Braking in Intersection – another world-first from Volvo Cars. If you should turn into the path of an oncoming car at a junction, your XC90 will brake automatically to mitigate a collision or prevent it altogether. The standard IntelliSafe technologies also include preventive safety features such as Road Sign Information, Lane Departure Warning and Electronic Stability Control. And it goes without saying that you also get Volvo's legendary strength. If you'd like to build on this, the IntelliSafe Surround option is designed to alert you to hazards all around your car, while the IntelliSafe Assist option assists you for a relaxed drive in the city or on the highway. For example, by helping you to keep a safe distance to the car ahead and avoid lane drifting by gently steering you back to your lane if it's needed.



In town, City Safety is designed to prevent you from colliding with the car in front if it stops suddenly. This advanced IntelliSafe system works at speeds of up to 50 km/h and senses if you're about to collide with another car, then, if necessary, applies the brakes.



We've further improved our Blind Spot Information System (BLIS). It now uses radar technology to alert you to vehicles closing up in your blind spot. There's also Cross Traffic Alert, which watches out for vehicles you can't see when you're reversing out of tight parking spaces.



Because we care about other road-users just as much as you, Pedestrian Detection with Full Auto-Brake watches out for people walking into your path and applies the brakes if you're unable to react in time.





ENJOYING MORE FOR LESS.

DRIVE-E

Drive-E is our all-embracing approach to efficient power and an uncompromising driving experience. Our new-generation Drive-E powertrains play a central role in this: in fact, they redefine how luxury cars will be powered in the 21st century. Yes, they deliver the performance and driving enjoyment you'd expect from a luxury SUV. But thanks to our unrelenting commitment to efficiency, they reduce the impact on the environment as well. All this means you get power and superb driveability together with low fuel consumption and CO₂ emissions.

The key to this is our all-new, lightweight, low-friction, turbo-charged 2.0l four-cylinder engine, which is coupled with our newly-designed automatic eight-speed Geartronic® transmission. And to maximise the efficiency of our Drive-E powertrains, there's an ECO mode, which calibrates the gearbox and engine control systems for the lowest possible fuel consumption. ECO mode also softens the throttle response to further boost efficiency. And because the air-conditioning impacts on fuel use, it is disengaged in ECO mode, although it can be switched on manually.

Then there's the Eco-Coast function, which uses the car's kinetic energy to save fuel. When the driver stops pressing the accelerator at speeds above 65 km/h, there is no engine braking; the car just coasts along with the engine at idle. And finally, the Stop/Start system also plays its part in lowering fuel consumption.

Our Drive-E diesel powertrain benefit from additional, diesel-specific technology. With twin turbos and the revolutionary i-ART direct fuel injection, this intelligent engine provides responsive, clean and efficient performance – each cylinder has its own microchip and pressure sensor for the perfect metering of fuel. Better still, this advanced engine remains in precise tune even after years of use.





" Our very powerful T8 Twin Engine AWD delivers astonishing performance without compromising on fuel efficiency and low emissions."

DOUBLE POWER.

YOUR ENGINE CHOICE

Nothing encapsulates our fresh thinking on 21st-century luxury and performance better than our top-of-the-range T8 Twin Engine AWD plug-in hybrid. Combining a super- and turbo-charged 2.0l Drive-E petrol powertrain with an electric motor, the T8 Twin Engine puts out an astonishing amount of horsepower, which it delivers with a jaw-dropping amount of torque. But it can also be driven with a fuel consumption which would put a compact car to shame. Not only does this petrol plug-in hybrid offer scintillating performance and amazing fuel efficiency – because the compact, high-capacity battery is mounted centrally along the transmission tunnel, the XC90 T8 Twin Engine AWD also handles supremely well.

It's versatile, too – the T8 Twin Engine AWD features different driving modes to suit virtually any driving environment. Pure mode is all about reducing fuel consumption and emissions. Working at speeds of up to 125km/h, it uses electric power as much as possible, sending it to the rear wheels. This mode packs ample reserves: a full battery suffices for most people's daily commute. But

because the high-performance petrol engine can be called upon at any time, there's never any worry about range.

Hybrid is the default mode. Geared to maximum comfort, this uses the electric motor at the rear wheels as well as the petrol engine, which drives the front wheels. It does this either individually or in parallel to achieve an optimum balance between performance and efficiency.

The Power mode, on the other hand, unleashes the combined forces of petrol and electric at the same time to all four wheels, while steering, transmission and brakes are tuned for sportiness. The AWD (all-wheel drive) mode improves traction and in addition, the Off Road mode engages an electronically controlled limited slip differential function and can help you negotiate poor roads at speeds below 40km/h. So your XC90 can be a silent-running zero-emission city car, a blistering performance SUV, or a reassuring companion in challenging conditions.

RDESIGN



A sporty presence

This version was made for those who love to drive. With a unique, expressive personality distinguished by the R-Design grille, sport Contour seats, and matte silver mirror covers.



Sports tailpipes

From behind, the dual integrated tailpipes give the all-new XC90 R-DESIGN a powerful, no-nonsense demeanour.

Sports steering wheel

Get to grips with this exclusive leather 3-spoke sports steering wheel with R-DESIGN logo.

Sports gear knob

A sporty gear knob with perforated leather, gives a performance ready look and feel.

Sports pedals

Racetrack inspired to enhance the driving experience, enjoy the feel of these ridged sports pedals.

Sports floor mats

These black, ribbed and richly tufted sports floor mats set the stage, front and back.

COLOUR YOUR VOLVO. When it comes to the appearance of your Volvo, the choice of exterior colour and wheels are probably your most important design decisions. For more exterior styling options and to build your new Volvo online, please visit www.volvocars.com/za



467 Magic blue metallic



477 Electric silver metallic (i)



487 Ember black metallic



492 Saville grey metallic (i)



612 Passion Red Solid (ii)



614 Ice white solid (i)



700 Twilight bronze metallic



707 Crystal white pearl metallic (i)



711 Bright silver metallic (i)



714 Osmium grey metallic (i)



717 Onyx black metallic (i)



719 Luminous sand metallic

(i) Also available for **REDESIGN** (ii) **REDESIGN** only

Please note: It's not possible to reproduce exact original shades in printed matter. Please ask your dealer to show you samples.

CLEAN COLOURS To reduce usage of environmentally hazardous solvents all Volvo exterior colours are water-based. What's more, our painting facilities are among the cleanest in the world.

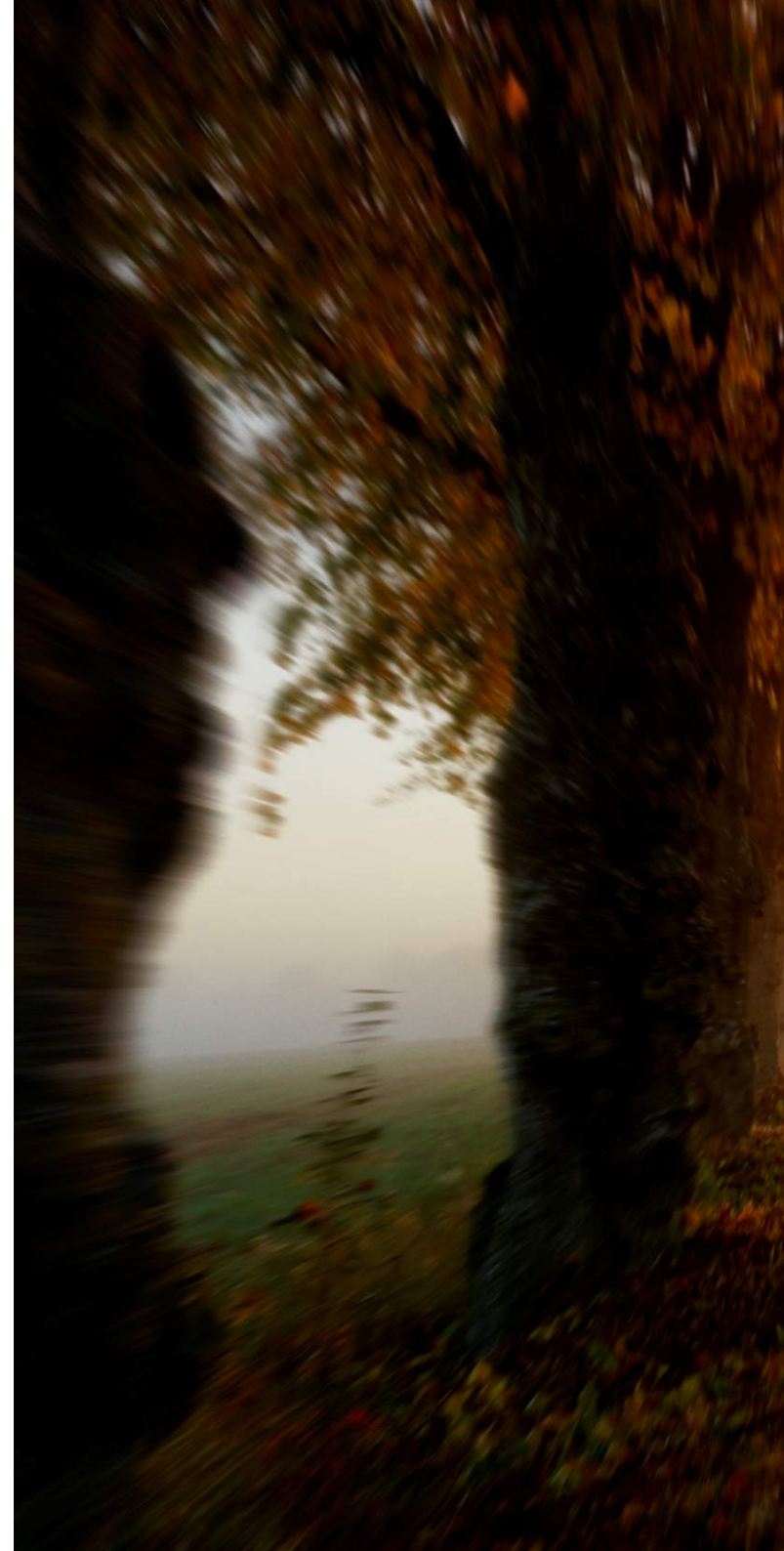



From expressive to discreet, elegant to sporty, you can give your XC90 a unique twist by the wheels you choose.

Would you like to make an entrance or do you prefer the charm of the understated? Are you going for a sporty persona or an intricate, refined look? Try different wheels on our online configurator and find the one that's right for you.



18" 6-Double Spoke Sparkling Silver Alloy Wheel



18" 5-Spoke Sparkling Silver Alloy Wheel



19" 10-Spoke Turbine Silver Alloy Wheel



19" 6-Spoke Turbine Silver Alloy Wheel





20" 10-Spoke Silver
Diamond Cut Alloy Wheel



20" 5-Double Spoke Tech Matt
Black Diamond Cut Alloy Wheel



20" 5-Spoke Matt Black
Diamond Cut Alloy Wheel
(*REDESIGN* only)



21" 8-Spoke Diamond Cut /
Silver Alloy wheel
(Inscription only)



22" 5-Double Spoke Matt Black
Diamond Cut Alloy Wheel
(*REDESIGN* only)

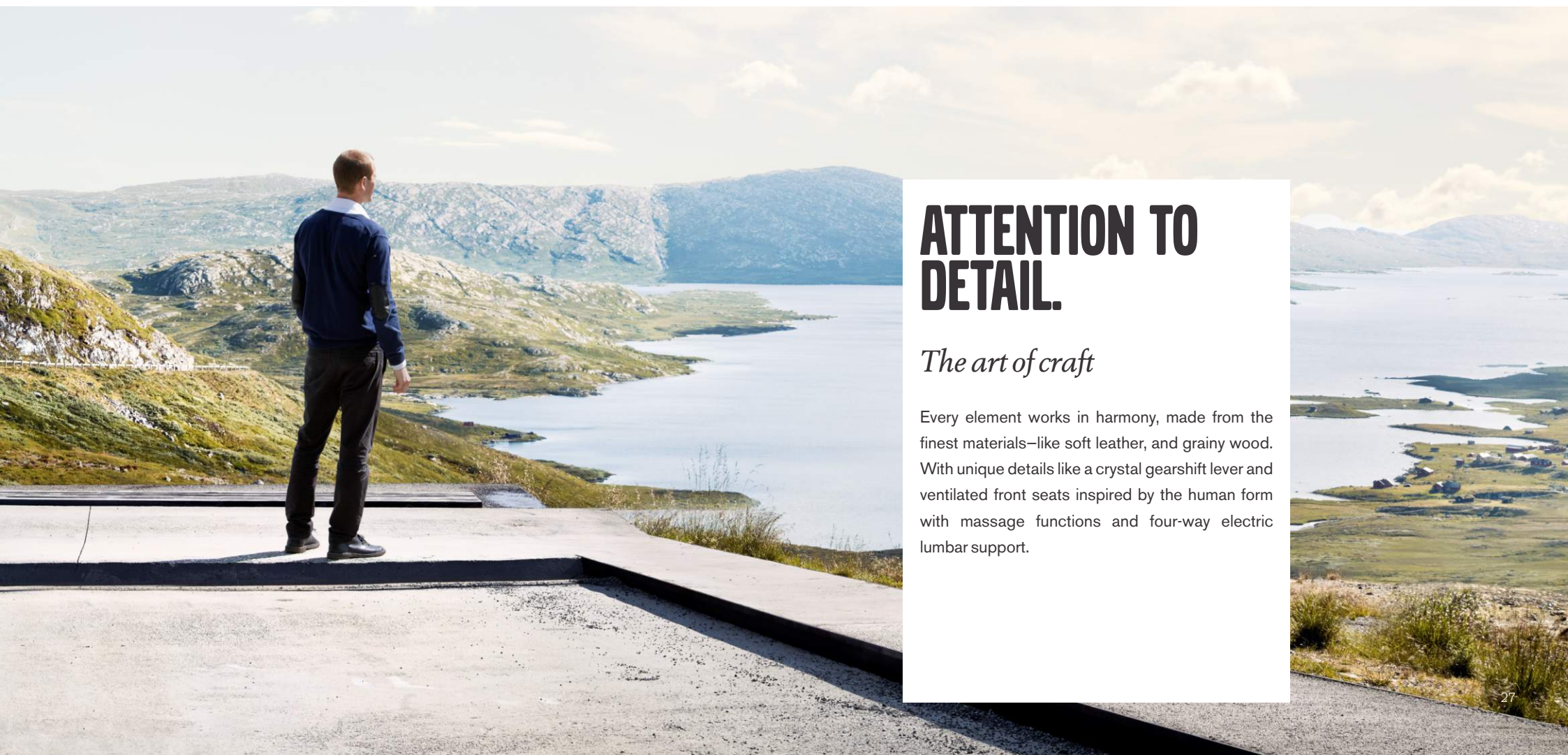

**ATTENTION TO
DETAIL.**

The art of craft

Every element works in harmony, made from the finest materials—like soft leather, and grainy wood. With unique details like a crystal gearshift lever and ventilated front seats inspired by the human form with massage functions and four-way electric lumbar support.

BESPOKE TAILORING FROM VOLVO.

The finest fabrics, superb stitching and minute attention to detail – whichever interior you choose for your all-new Volvo XC90, you'll be surrounded by luxury. How will you tailor yours?

NB It is not possible to reproduce exact original shades in printed matter.



We're very proud of the interior in the all-new XC90. Every detail, every line, every shape is testimony to our designers' untiring pursuit of their vision: to create a space in which you feel relaxed, at peace and in complete control. It's an airy, uncluttered cabin, which gives you astonishing scope to choose the upholstery and interior trim that suits your personality.

Choose the interior and seats in charcoal to create a dynamic, cockpit-like feel, the warm amber option to convey the mood of a luxurious lounge, or our futuristic blond theme. Then, you can complement the look by accenting the cabin with aluminium,

wood, carbon fibre or charcoal décor panels. There are two seat types: the standard comfort seats are designed to ensure a pleasant and luxurious drive even on the longest journey. They're available in leather and fine nappa leather. Then there are the power-operated, sculptured contour seats, which are available in fine nappa leather and particularly suited to dynamic driving. In the R-Design version, the contour seats are standard and upholstered in a combination of fine nappa leather and nubuck textile. You also have a choice between steering wheels – one dark, and one in a two-tone design.

Code	Description	Interior colour	Upholstery colour	Dashboard top	Door panel, lower dashboard, & upper tunnel console	Carpet & lower tunnel console	Door panel insert colour	Headliner colour
Standard leather								
RA00	Charcoal in charcoal	Charcoal	Charcoal	Charcoal	Charcoal	Charcoal	Charcoal	Blond
RA20	Amber in charcoal	Charcoal	Amber	Charcoal	Charcoal	Charcoal	Amber	Blond
WA00	Blond in blond	Blond	Blond	Charcoal	Blond	Blond	Blond	Blond
Nappa Soft Leather								
RB00	Charcoal in charcoal	Charcoal	Charcoal	Charcoal	Charcoal	Charcoal	Charcoal	Blond
RB20	Amber in charcoal	Charcoal	Amber	Charcoal	Charcoal	Charcoal	Amber	Blond
WB00	Blond in blond	Blond	Blond	Charcoal	Blond	Blond	Blond	Blond
Nappa Soft Leather - Sport Contour seat								
RB01	Charcoal in charcoal	Charcoal	Charcoal	Charcoal	Charcoal	Charcoal	Charcoal	Blond
RB21	Amber in charcoal	Charcoal	Amber	Charcoal	Charcoal	Charcoal	Amber	Blond
WB01	Blond in blond	Blond	Blond	Charcoal	Blond	Blond	Blond	Blond
Nappa Soft Leather - Perforated Ventilated seat								
RC00	Charcoal in charcoal	Charcoal	Charcoal	Charcoal	Charcoal	Charcoal	Charcoal	Blond
RC20	Amber in charcoal	Charcoal	Amber	Charcoal	Charcoal	Charcoal	Amber	Blond
WC00	Blond in blond	Blond	Blond	Charcoal	Blond	Blond	Blond	Blond
R-Design upholstery								
RB0R	Suede / Nappa sport leather	Charcoal	Charcoal	Charcoal	Charcoal	Charcoal	Charcoal	Charcoal
RC0R	Nappa Sport leather	Charcoal	Charcoal	Charcoal	Charcoal	Charcoal	Charcoal	Charcoal

INTERIOR DESIGN

Standard Leather



RA00



RA20



WA00



Cross Brushed Aluminium decor inlays

Nappa Soft Leather



RB00



RB20



WB00



Linear Walnut decor inlays

Nappa Soft Leather -
Sport Contour seat



RB01



RB21



WB01

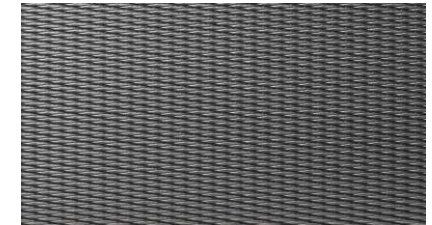

Metal Mesh decor inlays

Nappa Soft Leather -
Perforated Ventilated
seat



RC00



RC20



WC00



Dark Flame Birch decor inlays

R-Design Upholstery



RB0R

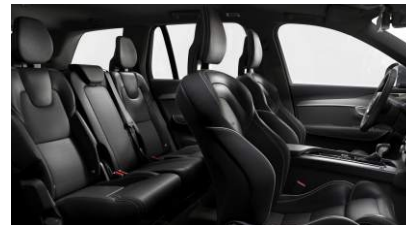

RC0R

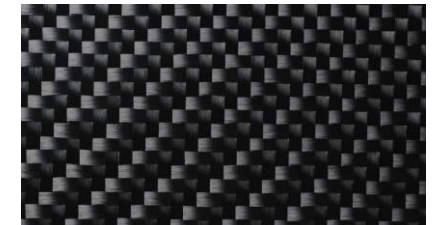

Carbon Fibre decor inlays





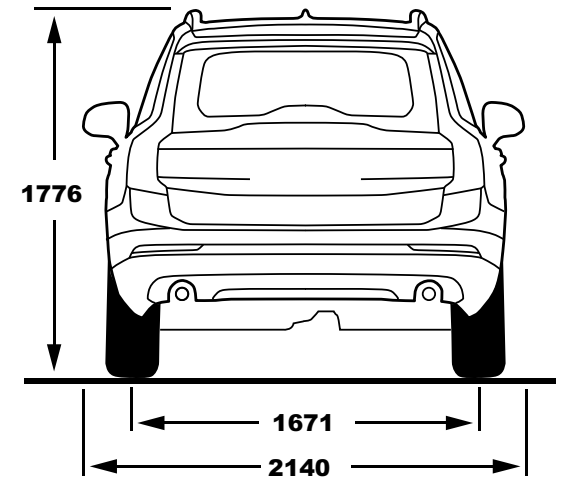
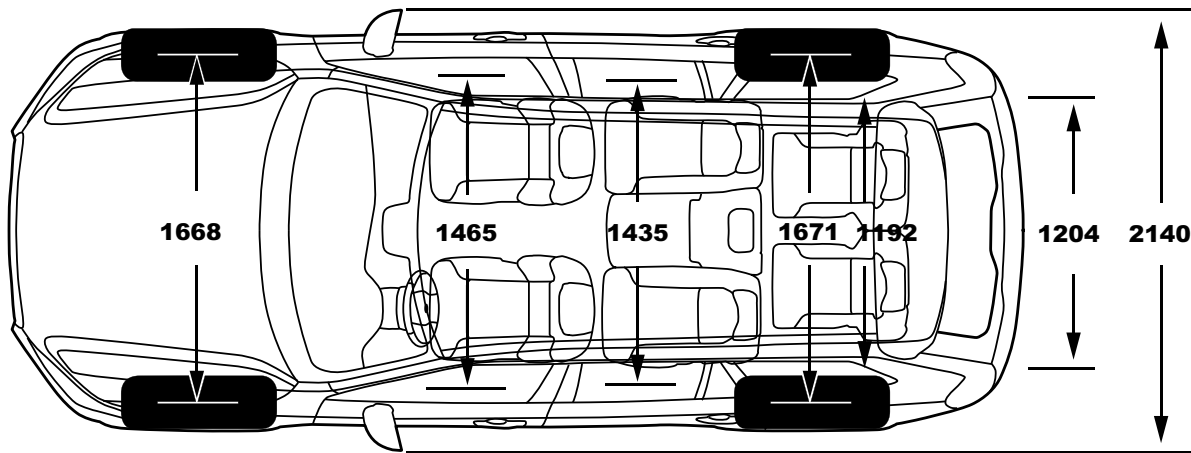
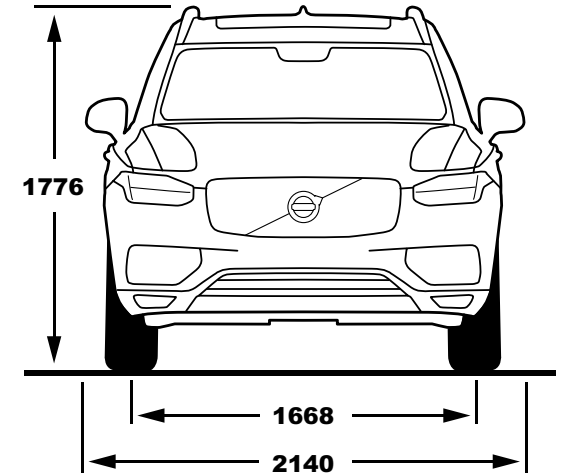
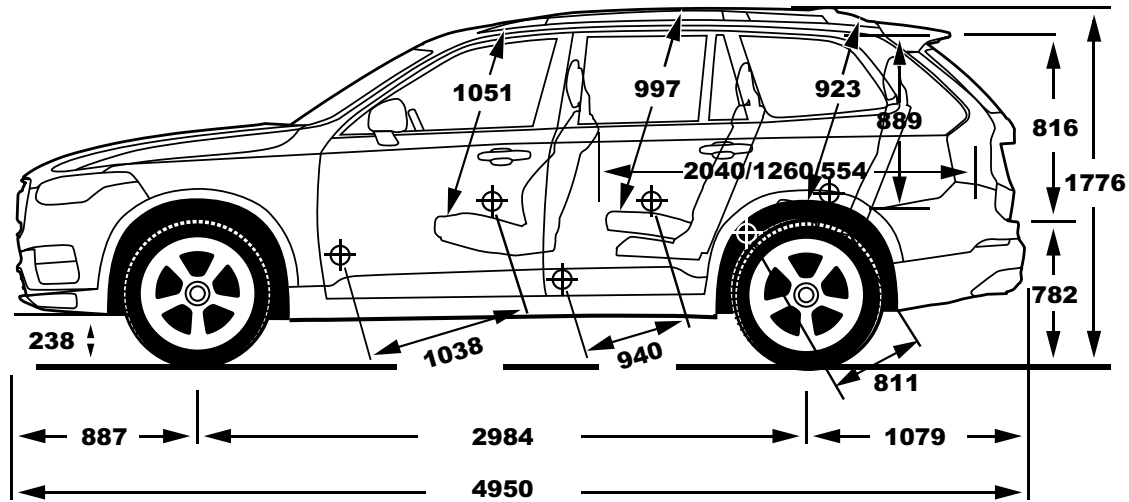

- (i) The results do not express or imply any guarantee of the fuel consumption of a particular car as there are inevitable differences between individual cars of the same model. Additionally, driving style, traffic conditions, as well as the age and mileage and standard of maintenance will affect a car's fuel consumption.
- (ii) The Urban fuel consumption figure is based on typical city driving, including starting the car from cold. The Extra Urban figure is based on typical motorway driving and cruising. The Combined figure averages the consumption across both cycles.
- (iii) Unbraked towing weight must not exceed 50% of kerb weight up to a maximum of approximately 750 kg.

Notes

The weight of the vehicle will influence the level of CO₂ emitted. As a result, vehicles with higher levels of specification and factory fit options may emit higher levels of CO₂.

A weighbridge must be used to determine specific weights. Data valid for manual transmission unless specified.

Gt = Geartronic Automatic Transmission.

All measurements in mm.

The Max. output figures are quoted in PS (Pferdestärke), which is the metric equivalent of brake horsepower.

NB Some of the information in this brochure may not be correct due to product changes which may have occurred since it was printed. Some of the equipment described or shown may now be available only at extra cost. Before ordering, please ask your Volvo dealer for the latest information. The manufacturer reserves the right to make changes at any time, without notice, colour, materials, specifications and models.

Volvo Car South Africa.

IN FINE DETAIL. The nuts and bolts of your all-new Volvo XC90. Whatever you need to know about your new car – whether that's fuel consumption, CO₂ emissions, top speed or boot space – you'll find it here.

ENGINE		D4 FWD Geartronic	D5 AWD Geartronic	T5 AWD Geartronic	T6 AWD Geartronic	T8 Twin Engine
Configuration		Transverse – 16 valve	Transverse – 16 valve	Transverse – 16 valve	Transverse – 16 valve	Transverse – 16 valve
Cylinders		4	4	4	4	4
Engine capacity, cc		1969	1969	1969	1969	1969
Bore x stroke, mm		82 x 93.2	82 x 93.2	82 x 93.2	82 x 93.2	82 x 93.2
Max. output ECE,	kW rpm	140 4250	165 4250	187 5500	235 5700	300 (235+65)
Max. torque ECE,	Nm rpm	400 1750-2500	470 1750-2500	380 1500-4800	400 2200-5400	640
Octane rating		50ppm Diesel	50ppm Diesel	95 RON unleaded	95 RON unleaded	95 RON unleaded
Fuel system		Twin Turbochargers	Twin Turbochargers	HP Turbocharger	Super & Turbocharged	Super & Turbocharged
Compression ratio		15,8:1	15,8:1	10,8:1	10,3:1	10,3:1

PERFORMANCE		D4 FWD Geartronic	D5 AWD Geartronic	T5 AWD Geartronic	T6 AWD Geartronic	T8 Twin Engine
Top speed km/h		210	220	230	230	230
Acceleration 0-100 km/h sec		10.2	7.8	7.9	6.5	5.6

FUEL CONSUMPTION		D4 FWD Geartronic	D5 AWD Geartronic	T5 AWD Geartronic	T6 AWD Geartronic	T8 Twin Engine
Combined	ℓ / 100 km	5.3	5.8	7.5	8.0	2.1
CO ₂	g/km	139	152	174	186	49
Fuel tank capacity	(litres)	71	71	71	71	50





TURNING CIRCLE	ALL MODELS
18" & 19" tyres	11.8 m
20", 21", and 22" tyres	12.2 m

LUGGAGE COMPARTMENT	ALL MODELS
Volume litres 2nd row seats up litres	692
Volume 3rd row seats up litres	314
Volume 2nd row seats folded litres	1057

TRANSMISSION	ALL MODELS
Geartronic AWD & FWD	8 speed

BRAKES	D4, D5, T5 & T6	T8 Twin Engine
Front disc diameter, mm	345	366
Rear disc diameter, mm	320	340

WEIGHT	D4 FWD Geartronic	D5 AWD Geartronic	T5 AWD Geartronic	T6 AWD Geartronic	T8 Twin Engine
Min. kerb weight, kg (actual kerb weight dependent on spec.)	TBC	2009	TBC	2004	2296
Max. possible towing weight braked, kg	TBC	2400	TBC	2400	2400
Max. towing weight unbraked, kg (iii)	TBC	750	TBC	750	750
Max. towball weight, kg	TBC	140	TBC	140	140
Max. total weight, kg	TBC	2750	TBC	2750	3010
Max. roof load, kg	TBC	100	TBC	100	100
Max. payload, kg (dependent on spec.)	TBC	712	TBC	717	689

GROUND CLEARANCE	ALL MODELS
Vehicle ground clearance, mm	238
with 2 persons, mm	227
Wading depth, mm	450
Approach angle	23.8°
Departure angle	23.3°
Breakover angle	21.3°





Volvo Car Financial Services

A division of 

My Volvo

A personalised website for you and your car.

My Volvo gives you:

- News and updates about your car ownership.
- Allows you to follow the main events during the ownership lifetime of your Volvo.
- Easy to reach your dealer for service booking.
- Tips to simplify your everyday life.
- Quick answers to questions about your car.
- Offers that are relevant to you and your car.
- Exclusive articles, films and photographs, plus behind-the-scenes look into the world of Volvo.
- Reminders regarding important stages of car ownership.

Everything you really need to know to get the most out of your Volvo.

On My Volvo, you'll find personalised offers and helpful information, exclusive articles and films, plus all the latest relevant news and updates from Volvo. You can also take advantage of innovative and useful functions, such as Online Service Booking. Everything is easy-to-use, easy-to-find and, most importantly, everything is designed with you and your particular Volvo model in mind.

Sign up at www.volvocars.com/za

The number to call is 0800 698 6586

Tracker Connect

On 1 January 2014, Tracker Connect became Volvo's new roadside assistance partner.

Tracker Connect has been South Africa's leading vehicle tracking company since the 1990s. While vehicle tracking and Stolen Vehicle Recovery (SVR) remains the company's core business, the Tracker of today has evolved into a highly sophisticated technological company offering leading edge fleet management and telematics solutions to both individuals and organisations throughout Southern Africa.

Services include:

- Medical emergency assistance
- Fuel assistance
- Recovery towing
- Emergency transportation
- "Stand by you" roadside security
- Free Mobile app
- Web access to conveniently position your vehicle or draw reports which can be used to log and submit business or private usage to SARS.
- Flat tyre assistance
- Battery service
- Overnight accommodation
- Accident tow
- Repatriation
- In-car Volvo assist button
- Impact detection
- Mileage monitoring
- Volvo Car South Africa branded smartphone app.

Furthermore, the option to include Proactive Vehicle Recovery for as little as R199* per month is also available. This option also includes access to value added services such as Care, Legal Assist and Theft Rescue.

* Reviewed and adjusted annually.

The number to call is 0800 698 6586

Volvo Car Financial Services

has flexible financing options that enable you to structure your deal according to your specific requirements.

We want your experience of buying and owning a Volvo to be enjoyable and hassle free, that is why we have developed the following online service tools:

- Online finance application – apply for finance anytime of the day or and get an instant answer.
- Calculators – calculate your monthly repayments or calculate the value of a vehicle that you could buy based on a specified monthly repayment.
- Account services – manage your account in a secure and user-friendly online environment in real time.

So, remember to insist on Volvo Car Financial Services at your dealer or simply visit www.volvocars.com/za for more information.

V O L V O

All models standard with a 5 year / 100 000km Volvo Plan.

NB Some of the information in this brochure may not be correct due to product changes which may have occurred since it was printed. Before ordering, please ask your Volvo dealer for the latest information. The manufacturer reserves the right to make changes at any time, without notice, to colour, materials, specifications and models.

VOLVOCARS.COM/ZA